

Vertex-minors,  
Monadic second-order logic,  
Polynomial algorithms  
and Seese's Conjecture

Bruno Courcelle, (Bordeaux)

joint work with Sang-il Oum, (Princeton)

*Based on :*

André Bouchet : Various articles on isotropic systems

B.C., S.O. : Vertex-minors, MS logic and a conjecture by

D. Seese, July 2004, submitted

<http://www.labri.fr/~courcell>

Sang-il Oum : Several articles, see above

The general field of this research could be entitled :

## Graph structuring and Monadic Second-order logic

*History* : The confluence of 4 independent research directions, presently intimately related :

1. Polynomial algorithms for NP-complete and other hard problems on particular classes of graphs, and especially hierarchically structured ones : series-parallel graphs, cographs, partial k-trees, graphs or hypergraphs of tree-width  $< k$ , graphs of clique-width  $< k$ .
2. Excluded minors and related notions of forbidden configurations (matroid minors, « vertex-minors »).
3. Decidability of Monadic Second-Order logic on classes of finite graphs, and on infinite graphs.
4. Extension to graphs and hypergraphs of the main concepts of **Formal Language Theory** : grammars, recognizability, transductions, decidability questions.

## Links between Monadic Second-Order Logic and graph structure properties

Tree-width	Clique-width $\equiv$ Rank-width
Bounded tree-width $\Leftrightarrow$ bounded $n \times n$ grids as minors	Bounded rank-width for bipartite graphs $\Leftrightarrow$ bounded " $S_k$ " graphs as <b>vertex-minors</b>
TWD( $\leq k$ ) is characterized by finitely many excluded minors	RWD( $\leq k$ ) is characterized by finitely many excluded <b>vertex-minors</b>
Monadic Second-Order ( <b>MS<sub>2</sub></b> ) problems are linear on TWD( $\leq k$ )	Monadic Second-Order (MS) problems are <b>polynomial</b> on CWD( $\leq k$ )
A set of graphs with a decidable <b>MS<sub>2</sub></b> satisfiability problem has bounded TWD	A set of graphs with a decidable <b>C<sub>2</sub>MS</b> satisfiability problem has bounded CWD
$G \rightarrow \text{Minors}(G)$ is an <b>MS<sub>2</sub></b> transduction	$G \rightarrow \text{Vertex-Minors}(G)$ is a <b>C<sub>2</sub>MS</b> transduction

This lecture :

Using the algebraic notion of **Isotropic System**, we express the vertex-minor relation in  $C_2MS$  logic and we (almost) prove Seese's Conjecture

Main definitions and steps :

- **local complementation, local equivalence, vertex-minors**
- the example of circle graphs
- informal and constructive introduction to **Isotropic Systems**,
- and how they **represent local equivalence**
- representation of these notions and constructions in  $C_2MS$  logic
- application to (a weakening of) Seese's Conjecture
- polynomial algorithm for "rank-width  $\leq k$ "

## Quick review of definitions : Clique-width

Tree-width : Well-known

Clique-width : defined in terms of graph operations

Graphs are simple, directed or not.

We use labels :  $a, b, c, \dots, h$ .

Each vertex has one and only one label ; a label  $p$  may label several vertices.

*Binary operation* : disjoint union  $\oplus$

*Unary operations* : Edge addition denoted by  $Add\text{-}edg_{a,b}$

$Add\text{-}edg_{a,b}(G)$  is  $G$  augmented with (un)directed edges from every  $a$ -labelled vertex to every  $b$ -labelled one.

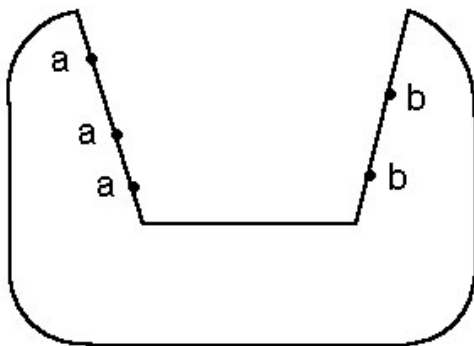

$G$

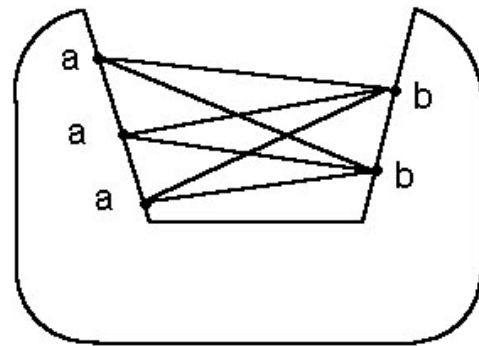

$Add\text{-}edg_{a,b}(G)$

$Relab_{a,b}(G)$  is  $G$  with every  $a$ -labelled vertex relabelled into  $b$ . (The effect is to merge two classes of the partition of the set of vertices defined by the labels.)

*Basic graphs* are those with a single vertex.

*Definition:* A graph  $G$  has clique-width  $\leq k$

$\Leftrightarrow$  it can be constructed from basic graphs  
by using  $\leq k$  labels and the  
operations  $\oplus$ ,  $Add-edg_{a,b}$   
and  $Relab_{a,b}$ .

Its (exact) clique-width,  $CWD(G)$ , is the  
minimum such  $k$ .

*Example :* Cliques have clique-width 2.

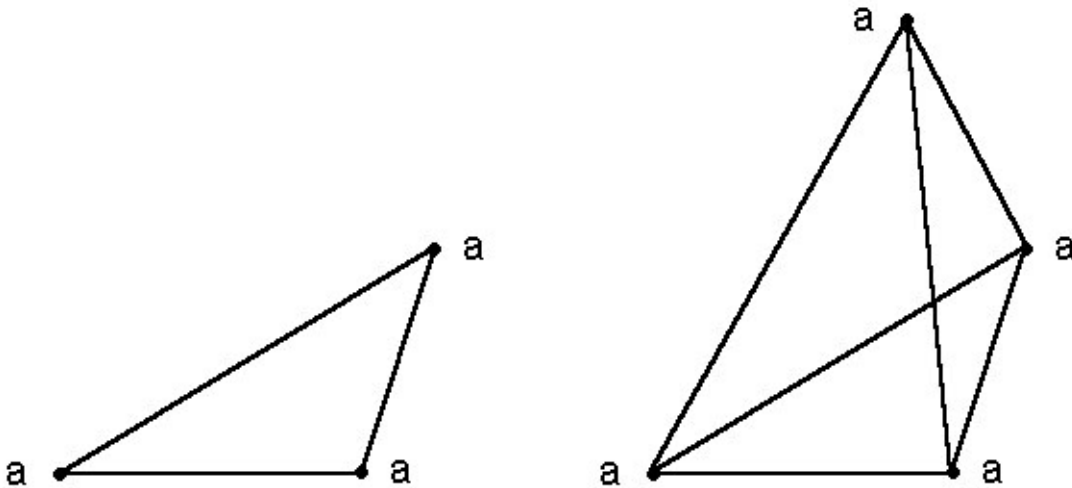

$K_n$  is defined by  $t_n$

$$t_{n+1} = Relab_{b,a}(Add-edg_{a,b}(t_n \oplus \mathbf{b}))$$

Bounded tree-width implies bounded **CWD** but not *vice-versa*

## Quick review of definitions : Logic

Monadic Second-Order (**MS**) logic = First-Order logic **with set variables**

---

*Example : Non connectivity of undirected graphs :*

$$\exists X ( \exists x \in X \ \& \ \exists y \notin X \ \& \\ \forall u,v (u \in X \ \& \ \text{edg}(u,v) \Rightarrow v \in X) )$$

---

**C<sub>2</sub>MS** = MS with the set predicate **Even(X)**

**MS<sub>2</sub>** = MS logic with edge set quantification  
= MS logic for graphs represented by their  
(bipartite directed) **incidence graphs**

The existence of a Hamiltonian circuit is MS<sub>2</sub> but not MS.

The **L satisfiability problem** for a logical language  $L$  and a set of structures  $C$  is :

the problem of deciding whether a given formula in  $L$  is satisfied by some structure in  $C$  (it is decidable iff the  $L$ -theory of  $C$  is decidable when  $L$  is closed under negation).

## Definitions : MS transductions

$\text{STR}(\Sigma)$  : the set of finite  $\Sigma$ -relational structures.

Multivalued mappings  $\tau : \text{STR}(\Sigma) \rightarrow \text{STR}(\Gamma)$

$$S \longmapsto T = \tau(S)$$

where  $T$  is :

- a) defined by MS formulas
- b) inside the structure:  $S \oplus S \oplus \dots \oplus S$   
(fixed number of disjoint "marked" copies of  $S$ )
- c) in terms of "parameters" i.e. subsets  $X_1, \dots, X_p$  of the domain of  $S$

*Proposition* : The composition of two

MS transductions is an MS transduction.

*Remark* : For each tuple of parameters  $X_1, \dots, X_p$

satisfying an MS property,  $T$  is uniquely defined.

$\tau$  is multivalued by the different choices of parameters.



## Example of an MS transduction : Minors

The **incidence** graph  $\text{Inc}(G)$  of  $G$  (undirected) is the directed bipartite graph :

$$\langle V_G \cup E_G, \text{inc}_G(.,.) \rangle \quad \text{where}$$

$\text{inc}_G(v,e) \Leftrightarrow v$  is a vertex incident with edge  $e$ .

The mapping :  $(\text{Inc}(G), X, Y) \longrightarrow \text{Inc}(H)$

where  $X \subseteq V_G \cup E_G$  : vertices and edges to delete

$Y \subseteq E_G$  : edges to contract

$H$  is the resulting minor

is an  $\text{MS}_2$  transduction.

(Because transitive closure and paths are expressible in MS logic.)

## The fundamental property of MS transductions :

$$\begin{array}{ccc} S & \xrightarrow{\quad} & \tau(S) \\ \tau^{\#}(\psi) & \xleftarrow{\quad} & \psi \end{array}$$

Every MS formula  $\psi$  has an effectively computable *backwards translation*  $\tau^{\#}(\psi)$ , an MS formula, such that :

$$S \models \tau^{\#}(\psi) \quad \text{iff} \quad \tau(S) \models \psi$$

The verification of  $\psi$  in the **object structure**  $\tau(S)$  **reduces** to the **verification** of  $\tau^{\#}(\psi)$  in the given structure  $S$ .

*Intuition* :  $S$  contain all necessary information to describe  $\tau(S)$  ; the MS properties of  $\tau(S)$  are expressible by MS formulas in  $S$

### Some results :

- 1) If a set of graphs  $C$  has a decidable MS satisfiability problem, so has its image  $\tau(C)$  under an MS transduction  $\tau$ .
- 2) A set of graphs has bounded **tree-width** iff it is the image of a set of **trees** under an **MS<sub>2</sub> transduction** (graphs are handled through incidence graphs, this permits edge set quantifications).
- 3) A set of graphs has bounded **clique-width** (or **rank-width**) iff it is the image of a set of **trees** under an **MS transduction**.

*Theorem* (Seese 1991) :

If a set of graphs has a decidable  $MS_2$  satisfiability problem, it has bounded **tree-width**.

*Conjecture* (Seese 1991) :

If a set of graphs has a decidable  $MS$  satisfiability problem, it is the image of a set of trees under an  $MS$  transduction, equivalently, has bounded **clique-width**.

*Theorem* (B.C., S. Oum 2004) :

If a set of graphs has a decidable  $C_2MS$  satisfiability problem, it has bounded clique-width.

---

*Reminder :*

$MS$  = (Basic)  $MS$  logic **without** edge quantifications

$MS_2$  =  $MS$  logic **with** edge quantifications

$C_2MS$  =  $MS$  logic with **even cardinality** set predicates

*Proof of Seese's Theorem :*

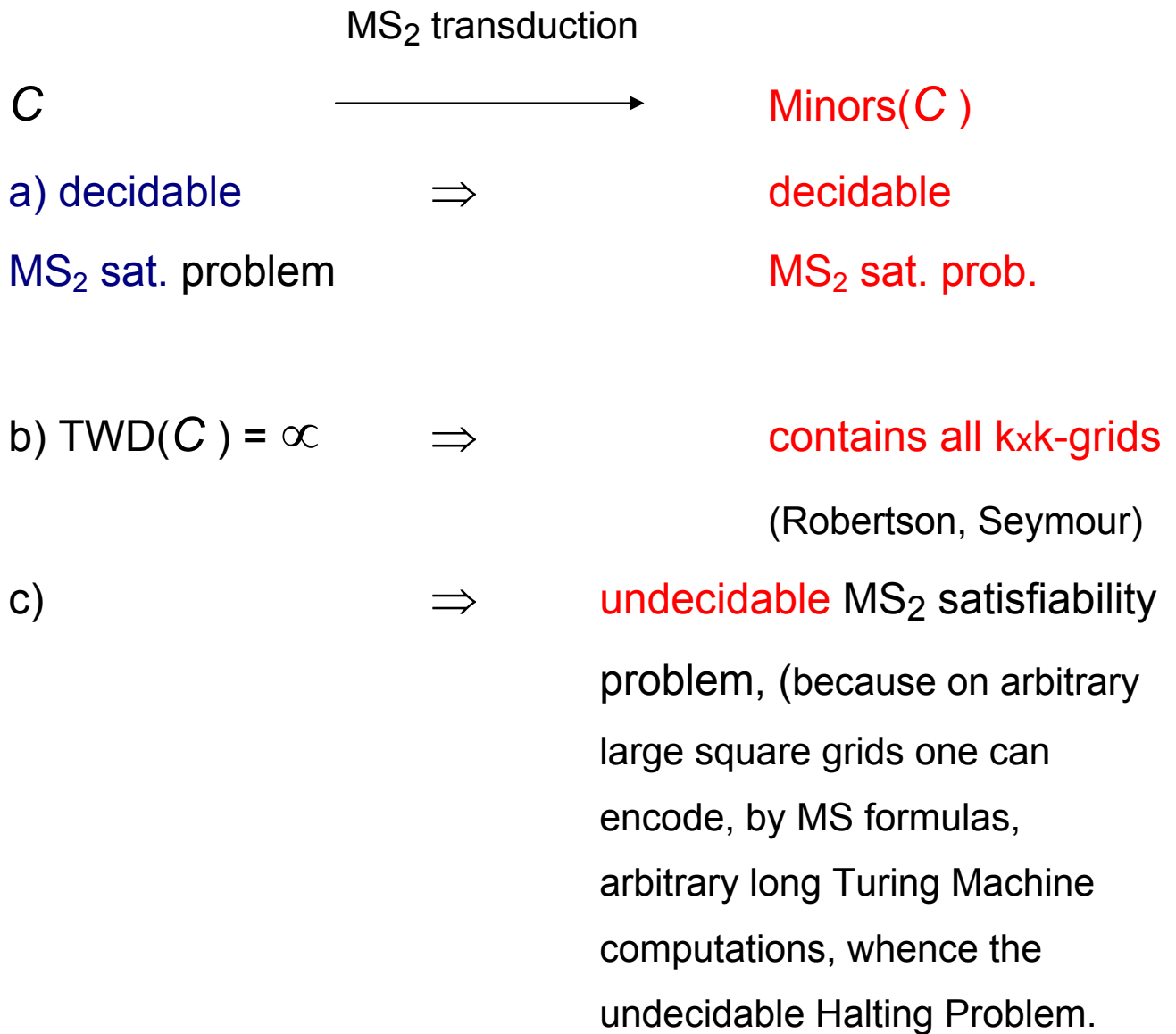

Hence “ $TWD(C) = \infty$ ” and “ $C$  has a decidable **MS<sub>2</sub> satisfiability** problem” yield a contradiction for the decidability of the **MS<sub>2</sub> satisfiability** problem of **Minors( $C$ )**.

*Proof of Courcelle-Oum's Theorem :*

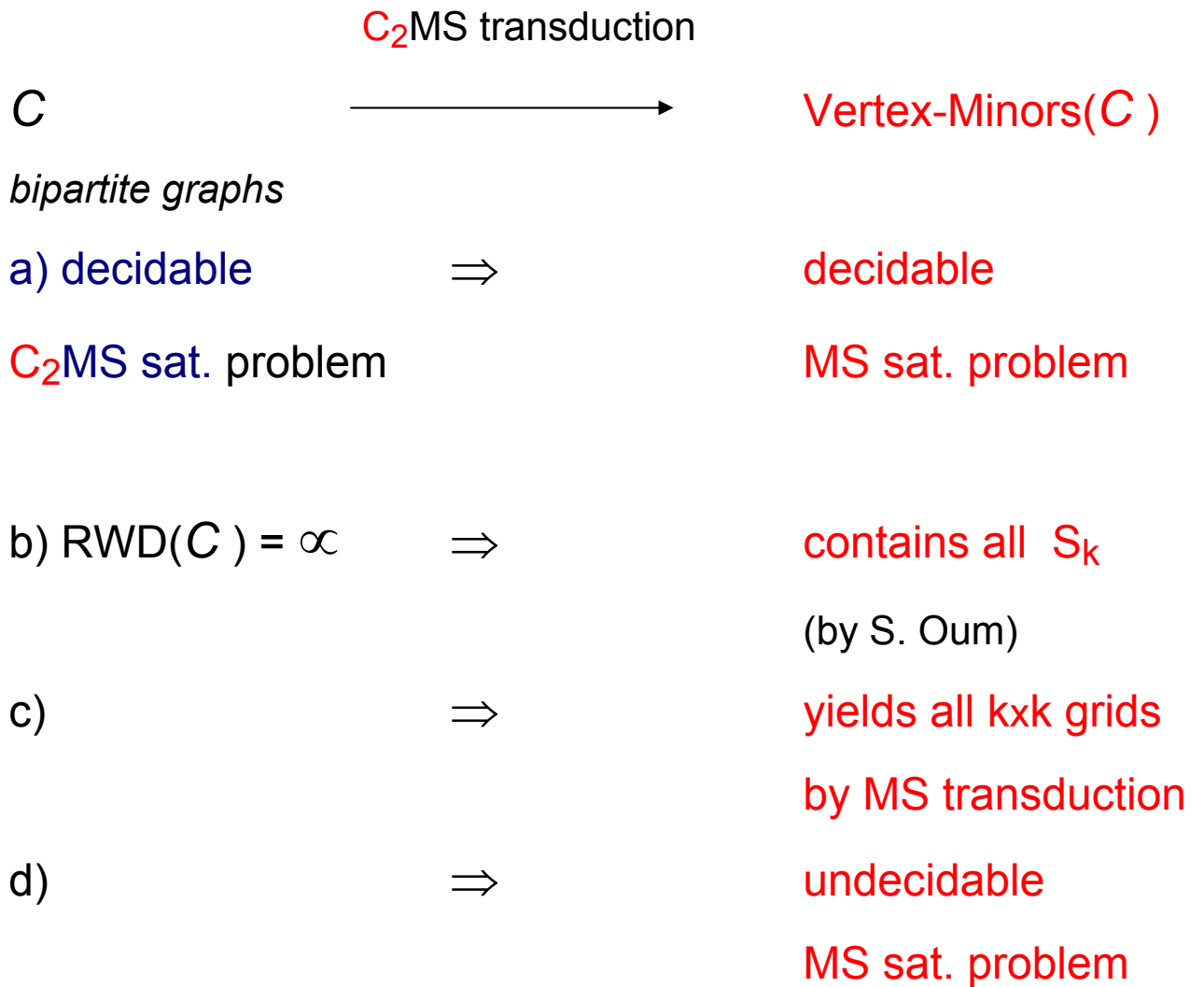

There are MS transductions encoding :

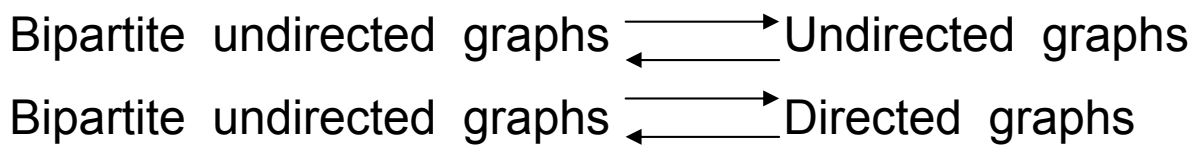

They preserve “bounded clique-width”

and decidability of the  $C_2MS$  satisfiability problem

This gives the proof.

## Definition : Vertex-Minor

(a notion already considered by A. Bouchet, 1987-1994)

Graphs : finite, undirected, simple, loop-free

**Local complementation** of  $G$  at vertex  $v$

$G * v = G$  with edge complementation of  $G[n_G(v)]$ ,

the subgraph induced by the **neighbours** of  $v$

**Local equivalence** ( $\approx_{loc}$ ) = transitive closure of local complementation (at any vertex).

Vertex-minor relation :

$H \leq_{VM} G : \Leftrightarrow H$  is an induced subgraph of some  $G' \approx_{loc} G$

Theorems (S. Oum) : 1) Vertex-minor relation is wqo on graphs of **rank-width**  $\leq k$ .

2) These graphs are defined by finitely many excluded vertex-minors with at most  $\leq 6^{k+1} / 5$  vertices.

3) **Rank-width** is equivalent to clique-width.

# Properties of local complementation and vertex minors

**Facts** :  $G * v * w = G * w * v$  if  $v, w$  not adjacent (easy)

$G * v * w = G * w * v * W * v$  if  $v, w$  adjacent (harder)

$G * X$  easy to define in  $G$  by a  $C_2MS$  formula if  $X$  is stable

$G * X$  is not well-defined if  $X$  is not stable

**Notation** :  $\subseteq_i$  induced subgraph

**Facts** :  $G \approx_{loc} G' \subseteq_i H \Rightarrow G \subseteq_i H' \approx_{loc} H$  for some  $H'$

$\leq_{VM}$  is the transitive closure of  $\approx_{loc} \cup \subseteq_i$

**Proposition** : The mappings from  $G$  to its locally equivalent graphs, and to its vertex minors are  $C_2MS$  transductions.

Why the even cardinality set predicate is necessary ?

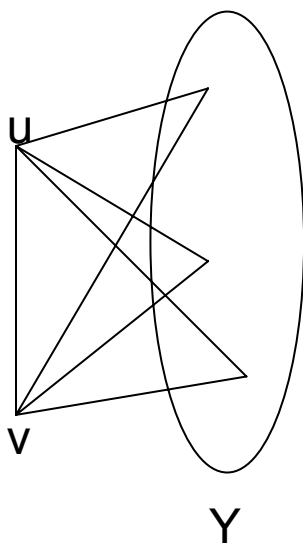

Consider  $G * X$  for  $X \subseteq Y$  :

$u$  is linked to  $v$  in  $G * X$

$\Leftrightarrow \text{Card}(X)$  is even

G

*Proposition* : The mappings from  $G$  to its locally equivalent graphs is a  $C_2MS$  transduction.

*Proof* : It is the composition of two transductions :

- a)  $G$ , graph  $\rightarrow S(G)$ , isotropic system : a  $C_2MS$  transduction,
- b)  $S$ , isotropic system  $\rightarrow$  graphs  $H$  definable from it : an MS transduction.

The graphs  $H$  are the graphs locally equivalent to  $G$ .

*Consequences (with other results)* :

- 1) The set of graphs of rank-width at most  $k$  is characterized by a  $C_2MS$  formula.
- 2) So is the set of circle graphs.
- 3) It is decidable in polynomial time if a graph has rank-width  $\leq k$ , for each fixed  $k$ .



## Seese's Conjecture : Some lemmas

- (1) MS transductions can encode/decode graphs into bipartite graphs. They preserve “bounded rank-width/cliue-width” and “having a decidable  $C_2$ MS satisfiability problem” in both directions

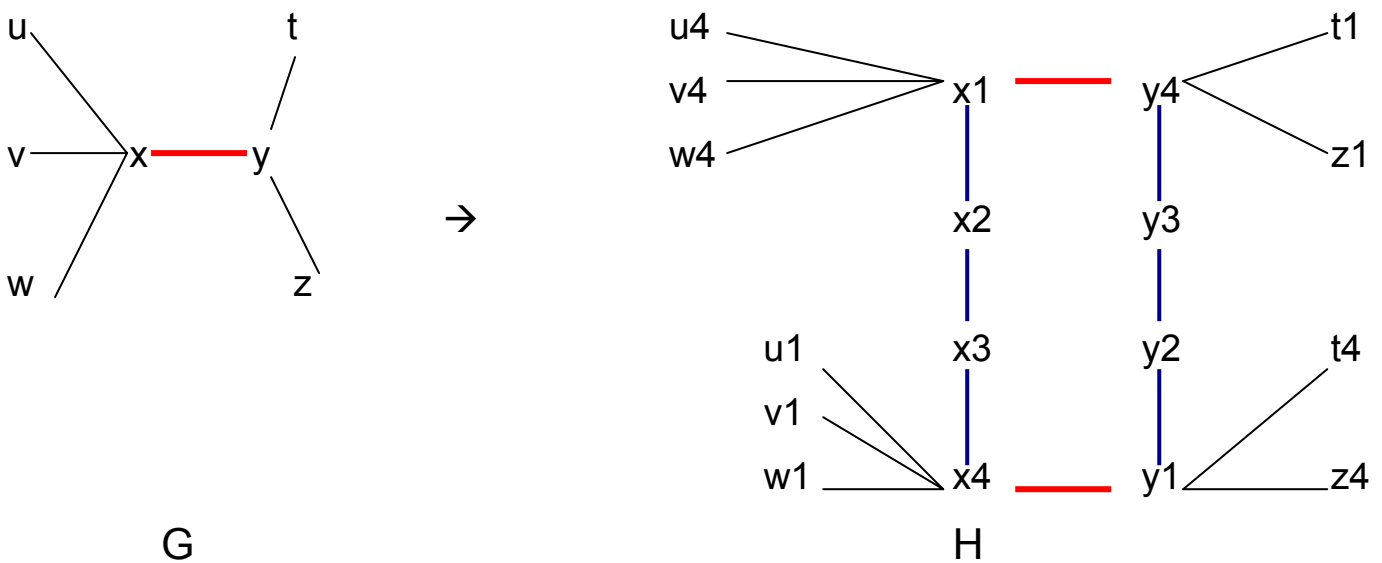

From  $H$  to  $G$  : contract the blue edges, fuse parallel red edges.

- (2) It remains to show the graphs  $S_k$  and the MS transduction that transforms them into  $k \times k$ -grids.

Definition of  $S_k$  :

bipartite :  $A = \{1, \dots, (k+1)(k-1)\}$  ,  $B = \{1, \dots, k(k-1)\}$

for  $j \in A, i \in B : \text{edg}(i,j) \Leftrightarrow i \leq j \leq i+k-1$

From  $S_k$  to  $\text{Grid}_{k \times k}$  by an MS transduction

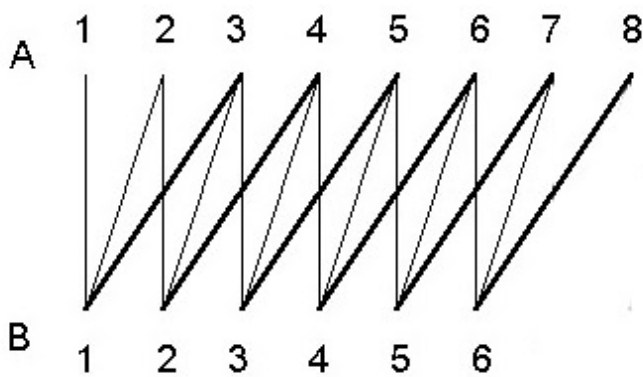

$S_3$

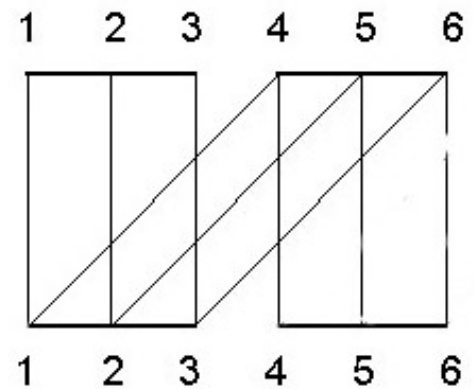

$\text{Grid}_{3 \times 4}$

1) One can define the orderings of A and B :

$$x, y \text{ are consecutive} \Leftrightarrow \text{Card}(n_G(x) \Delta n_G(y)) = 2$$

2) One can identify the edges from  $i \in B$  to  $i \in A$ , and

from  $i \in B$  to  $i+k-1 \in A$  (thick edges on the left drawing)

3) One can create edges (e.g. from  $1 \in A$  to  $2 \in A$ , from  $2 \in A$

to  $3 \in A$  etc...and similarly for B, and from  $1 \in B$  to  $4 \in A$ ,

etc...) and delete others (from  $4 \in B$  to  $6 \in A$  etc...), and

vertices like 7,8 in A, to get a grid containing  $\text{Grid}_{k \times k}$

Theorem : If a set of (finite, simple, undirected) graphs has a decidable  $C_2MS$  satisfiability problem, then :

it has bounded rank-width,

it has bounded clique-width,

it is the image of a set of trees under an MS transduction.

Corollary : If a set of (finite, simple), directed graphs has a decidable  $C_2MS$  satisfiability problem, then :

it has bounded clique-width,

it is the image of a set of trees under an MS transduction.

*Proof* : By using codings between directed and undirected graphs by MS transductions (B. Courcelle, 2002-2004, submitted) showing that Seese's Conjecture holds for directed graphs iff it holds for undirected ones.

Corollary : If a set of directed acyclic graphs, each of them having a directed Hamiltonian path, has a decidable  $MS$  satisfiability problem, then it has bounded clique-width.

*Proof* : Since on these graphs a linear order is MS definable,  $MS$  and  $C_2MS$  logics are equivalent (every  $C_2MS$  formula is translatable into an equivalent MS formula).

## *Algorithmic applications*

On graphs of clique-width  $\leq k$ ,

each monadic second-order property, (ex. 3-colorability)

each monadic second-order optimization function, (ex. distance)

each monadic second-order counting function, (ex. # of paths)

is evaluable :

(1) in linear time on graphs given by a term over  
the clique-width operations

(2) in time  $O(n^9 \cdot \log(n))$  otherwise (S. Oum, P. Seymour).

Proof sketch of (2) : For each  $k$ , there is a  $O(n^9 \cdot \log(n))$  algorithm that gives for any graph  $G$  :

either that  $RWD(G)$  (or  $CWD(G)$ )  $> k$

or a decomposition of width  $\leq 3k + 1$  for  $RWD$  ( $\leq 2^{3k+2}$  for  $CWD$ )

In the second case we get, by using (1), the correct answer in polynomial time, although the decomposition is not optimal.

*Corollary* : This applies to the question “ $RWD(G) \leq k$ ” since this class is MS definable (through finitely many excluded vertex minors).

## Open problems

- 1) Can one find a good sounding name in French for “vertex-minor” ?
- 2) Does the original conjecture by Seese hold (with MS instead of  $C_2MS$ ) ?
- 3) Does it hold for relational structures (i.e., directed ranked hypergraphs) ?
- 4) Can one defined rank-width for directed graphs ? and for hypergraphs ?
- 5) If two graphs  $G, H$  are locally equivalent, they have the same rank-width  $RWD(G)$  but clique-widths such that :  
$$RWD(G) \leq CWD(G), CWD(H) \leq 2^{RWD(G)+1} - 1$$

What are the maximum and minimum values of  $CWD(H)$  ?  
Can one characterize the graphs that realize these values ?
- 6) Can one characterize  $RWD(\leq k)$  in terms of graph operations?
- 7) Is “ $CWD(\leq k)$ ” polynomial ?