

# Independent Domination in Cubic Graphs

<sup>1</sup>Paul Dorbec, <sup>2</sup>Michael A. Henning\*, <sup>3</sup>Mickael Montassier, and <sup>2</sup>Justin Southey\*

<sup>1</sup>Univ. Bordeaux, LaBRI, UMR5800, F-33405 Talence  
CNRS, LaBRI, UMR5800, F-33405 Talence  
Email: dorbec@labri.fr

<sup>2</sup>Department of Mathematics  
University of Johannesburg  
Auckland Park 2006, South Africa  
Email: mahenning@uj.ac.za; just.so@presentable.me

<sup>3</sup>Université Montpellier 2, CNRS-LIRMM  
UMR 5506 Montpellier, France  
Email: mickael.montassier@lirmm.fr

## Abstract

A set  $S$  of vertices in a graph  $G$  is an independent dominating set of  $G$  if  $S$  is an independent set and every vertex not in  $S$  is adjacent to a vertex in  $S$ . The independent domination number of  $G$ , denoted by  $i(G)$ , is the minimum cardinality of an independent dominating set. In this paper, we show that if  $G \neq C_5 \square K_2$  is a connected cubic graph of order  $n$  that does not have a subgraph isomorphic to  $K_{2,3}$ , then  $i(G) \leq 3n/8$ . As a consequence of our main result, we deduce Reed's important result [Combin. Probab. Comput. 5 (1996), 277–295] that if  $G$  is a cubic graph of order  $n$ , then  $\gamma(G) \leq 3n/8$ , where  $\gamma(G)$  denotes the domination number of  $G$ .

**Keywords:** Independent domination number; domination number; cubic graphs.

**AMS subject classification:** 05C69

---

\*Research supported in part by the South African National Research Foundation and the University of Johannesburg

# 1 Introduction

Let  $G = (V, E)$  be a graph. A *dominating set* of  $G$  is a set  $S$  of vertices of  $G$  such that every vertex in  $V \setminus S$  is adjacent to a vertex in  $S$ . The *domination number* of  $G$ , denoted by  $\gamma(G)$ , is the minimum cardinality of a dominating set. An *independent dominating set*, abbreviated ID-set, of  $G$  is a set that is both dominating and independent in  $G$ . Equivalently, an independent dominating set is a maximal independent set. The *independent domination number* of  $G$ , denoted by  $i(G)$ , is the minimum cardinality of an ID-set and an ID-set of cardinality  $i(G)$  in  $G$  is called an  $i(G)$ -set. Independent dominating sets have been studied extensively in the literature; see for example the books [4, 5]. In this paper, we consider the independent domination number of cubic graphs.

The question of best possible bounds on the independent domination number of a connected cubic graph remains unresolved. Lam, Shiu, and Sun [10] established the following upper bound on the independent domination number of a connected cubic graph.

**Theorem 1** ([10]) *For a connected cubic graph  $G$  on  $n$  vertices,  $i(G) \leq 2n/5$  except for  $K_{3,3}$ .*

Recall that  $K_{3,3}$  denotes the bipartite complete graph with both partite sets on three vertices. Equality in Theorem 1 holds for the prism  $C_5 \square K_2$  (see Figure 2). It is conjectured in [2] that the graphs  $K_{3,3}$  and  $C_5 \square K_2$  are the only exceptions for an upper bound of  $3n/8$ .

**Conjecture 1** ([2]) *If  $G \notin \{K_{3,3}, C_5 \square K_2\}$  is a connected cubic graph on  $n$  vertices, then  $i(G) \leq 3n/8$ .*

Two infinite families  $\mathcal{G}_{\text{cubic}}$  and  $\mathcal{H}_{\text{cubic}}$  of connected cubic graphs with independent domination number three-eighths their orders can be constructed as follows. We first construct graphs in  $\mathcal{G}_{\text{cubic}}$ . For  $k \geq 1$ , consider two copies of the cycle  $C_{4k}$  with respective vertex sequences  $a_1 b_1 c_1 d_1 \dots a_k b_k c_k d_k$  and  $w_1 x_1 y_1 z_1 \dots w_k x_k y_k z_k$ . For each  $1 \leq i \leq k$ , join  $a_i$  to  $w_i$ ,  $b_i$  to  $x_i$ ,  $c_i$  to  $z_i$ , and  $d_i$  to  $y_i$ .

Graphs in  $\mathcal{H}_{\text{cubic}}$  are constructed as follows. For  $\ell \geq 1$ , consider a copy of the cycle  $C_{3\ell}$  with vertex sequence  $a_1 b_1 c_1 \dots a_\ell b_\ell c_\ell$ . For each  $1 \leq i \leq \ell$ , add the vertices  $\{w_i, x_i, y_i, z_i^1, z_i^2\}$ , and join  $a_i$  to  $w_i$ ,  $b_i$  to  $x_i$ , and  $c_i$  to  $y_i$ . Finally, for each  $1 \leq i \leq \ell$  and  $j \in \{1, 2\}$ , join  $z_i^j$  to each of the vertices  $w_i, x_i$ , and  $y_i$ .

Graphs in the families  $\mathcal{G}_{\text{cubic}}$  and  $\mathcal{H}_{\text{cubic}}$  are illustrated in Figure 1.

**Proposition 2** ([3]) *If  $G \in \mathcal{G}_{\text{cubic}} \cup \mathcal{H}_{\text{cubic}}$  has order  $n$ , then  $i(G) = 3n/8$ .*

It is remarked in [2] that “perhaps it is even true that for  $n > 10$ ,  $i(G) \leq 3n/8$  with equality if and only if  $G \in \mathcal{G}_{\text{cubic}} \cup \mathcal{H}_{\text{cubic}}$ . We remark that computer search has confirmed this is true when  $n \leq 20$ .”

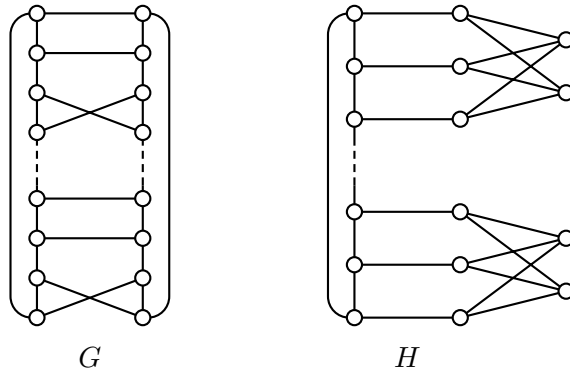

Figure 1: Graphs  $G \in \mathcal{G}_{\text{cubic}}$  and  $H \in \mathcal{H}_{\text{cubic}}$  of order  $n$  with  $i(G) = i(H) = 3n/8$ .

In this paper, we prove a general bound on the independent domination number of  $K_{2,3}$ -free graphs. As a corollary, we get that if  $G \neq C_5 \square K_2$  is a connected cubic graph of order  $n$  that does not have a subgraph isomorphic to  $K_{2,3}$ , then  $i(G) \leq 3n/8$ . This supports Conjecture 1. As a consequence of our main result, we also deduce that if  $G$  is a cubic graph of order  $n$ , then  $\gamma(G) \leq 3n/8$ , dropping the assumption that  $G$  does not have a subgraph isomorphic to  $K_{2,3}$ . This implies the main part of Reed's important result [9] that if  $G$  is an  $n$  vertices graph with minimum degree 3, then  $\gamma(G) \leq 3n/8$ .

We proceed first with some notations, then prove our main result in Section 3. In Section 4, we describe how our result takes place in a more general context and give a new proof of Reed's result [9].

## 2 Notation

For notation and graph theory terminology we generally follow [4]. Specifically, let  $G = (V, E)$  be a graph with vertex set  $V$  of order  $n(G) = |V|$  and edge set  $E$  of size  $m(G) = |E|$ , and let  $v$  be a vertex in  $V$ . We denote the *degree* of  $v$  in  $G$  by  $d_G(v)$ . The maximum (minimum) degree among the vertices of  $G$  is denoted by  $\Delta(G)$  ( $\delta(G)$ , respectively). The *open neighborhood* of  $v$  is  $N_G(v) = \{u \in V \mid uv \in E\}$  and the *closed neighborhood* of  $v$  is  $N_G[v] = \{v\} \cup N_G(v)$ . For a set  $S \subseteq V$ , its *open neighborhood* is the set  $N_G(S) = \bigcup_{v \in S} N_G(v)$ , and its *closed neighborhood* is the set  $N_G[S] = N_G(S) \cup S$ . We use the same notation when  $H$  is a subgraph of  $G$  to denote the neighborhood of its set of vertices.

A *cycle* on  $n$  vertices is denoted by  $C_n$  and a *path* on  $n$  vertices by  $P_n$ . The *girth* of  $G$ , denoted  $g(G)$ , is the length of a shortest cycle in  $G$ . A component of a graph  $G$  isomorphic to a graph  $F$  we call an *F-component* of  $G$ . For a set  $S \subseteq V$ , the subgraph induced by  $S$  is denoted by  $G[S]$ . Further if  $S \neq V$ , then we denote the graph obtained from  $G$  by deleting all vertices in  $S$  (as well as all incident edges) by  $G - S$ . A graph  $G$  is said to be *subcubic* if its maximum degree is at most 3, and *cubic* if it is 3-regular. Let  $n_j(G)$  denote the number of vertices of degree  $j$  in  $G$ .

A vertex of degree 0 is called an *isolated vertex*. The graphs  $K_{2,3}$  and  $C_5 \square K_2$  are depicted in Figure 2.

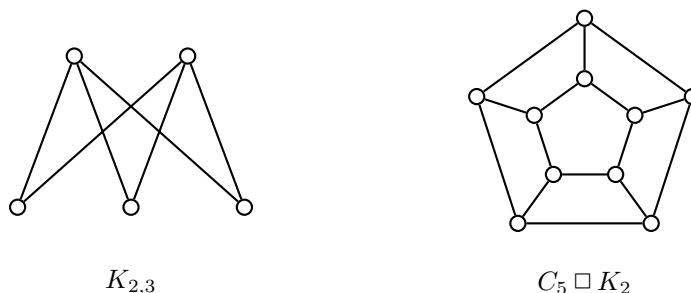

Figure 2: The graphs  $K_{2,3}$  and  $C_5 \square K_2$ .

### 3 Main Result

**Theorem 3** *If  $G$  is a subcubic graph that does not have a subgraph isomorphic to  $K_{2,3}$  and which has no  $(C_5 \square K_2)$ -component, then*

$$8i(G) \leq 8n_0(G) + 5n_1(G) + 4n_2(G) + 3n_3(G).$$

**Corollary 4** *If  $G \neq C_5 \square K_2$  is a connected cubic graph of order  $n$  that does not have a subgraph isomorphic to  $K_{2,3}$ , then  $i(G) \leq 3n/8$ .*

We remark that the bound in Corollary 4 is sharp, since graphs in the family  $\mathcal{G}_{\text{cubic}}$  do not contain a subgraph isomorphic to  $K_{2,3}$  and, by Proposition 2, achieve this bound exactly. Note also that the condition in Theorem 3 that  $G$  does not contain an induced  $K_{2,3}$  cannot be dropped. Indeed, the graph obtained by attaching a leaf to a degree 2 vertex of  $K_{2,3}$  (or equivalently by deleting two adjacent edges in  $K_{3,3}$ ) has no independent dominating set of size less than three. Therefore,  $8i(G) = 24 > 22 = 8n_0(G) + 5n_1(G) + 4n_2(G) + 3n_3(G)$ .

**Proof of Theorem 3.** To prove this result, we show that there exist no minimum counterexample. By way of contradiction, let  $G = (V(G), E(G))$  be a counterexample to Theorem 3 with minimum order. Clearly  $G$  is connected and contains at least four vertices. To prove that  $G$  does not exist, we first prove many structural properties of  $G$ , using contradiction on the minimality of  $G$  (i.e. we find a proper subgraph of  $G$  that must also be a counterexample to the theorem if  $G$  is one). With Claims 3.2 to 3.3, we prove the minimum degree of  $G$  is at least 2. Then we prove  $G$  is 3-regular with Claims 3.4 to 3.7. Finally, we prove the non existence of cycles of length at most 7 in the graph (Claims 3.8 to 3.14), and conclude using the smallest cycle to reach a contradiction (Claim 3.15).

Before proceeding with the proof, we first introduce some additional useful notation and prove two facts which will be used throughout the proof of Theorem 3. For a vertex  $v$  of  $G$ , we define its *weight* in  $G$  as

$$\omega_G(v) = \begin{cases} 8 & \text{if } d_G(v) = 0 \\ 5 & \text{if } d_G(v) = 1 \\ 4 & \text{if } d_G(v) = 2 \\ 3 & \text{if } d_G(v) = 3, \end{cases}$$

and for a subset  $X \subseteq V(G)$ , we define the *weight* of  $X$  in  $G$ , as

$$\omega_G(X) = \sum_{v \in X} \omega_G(v),$$

that is, the sum of the weights in  $G$  of vertices in  $X$ . We refer to the weight of  $V(G)$  (the entire vertex set) in  $G$  simply as the weight of  $G$ , or  $\omega(G)$ . Thus,

$$\omega(G) = \omega_G(V(G)) = \sum_{v \in V(G)} \omega_G(v) = 8n_0(G) + 5n_1(G) + 4n_2(G) + 3n_3(G).$$

We note that some vertices have a higher weight in  $G - X$  than in  $G$ . Specifically, those vertices with a lower degree in  $G - X$  or, equivalently, those adjacent in  $G$  to some vertex from  $X$ . We refer to the sum of these weight increases as the *cost of removing  $X$*  from  $G$  and denote it  $\psi_G(X)$ . That is,

$$\psi_G(X) = \sum_{v \notin X} (\omega_{G-X}(v) - \omega_G(v)).$$

We note that the degree of a vertex cannot increase by removing  $X$ , so each term in this sum is non-negative. Now, the weight of  $G - X$  is precisely the weight of  $G$ , less the weight of  $X$  in  $G$ , plus the cost of removing  $X$  from  $G$ , or, using our new notation:

$$\omega(G - X) = \omega(G) - \omega_G(X) + \psi_G(X).$$

Finally, we call an edge an *exit edge* of  $X$  in  $G$  if it joins a vertex in  $X$  to a vertex not in  $X$  and we denote the number of exit edges of  $X$  in  $G$  by  $\xi_G(X)$ . We now prove the useful fact that the cost of removing  $X$  from  $G$  is equal to the number of exit edges of  $X$  in  $G$  plus twice the number of isolated vertices in  $G - X$ . Consequently, if removing  $X$  yields no isolated vertices, then the cost of removing  $X$  from  $G$  will be precisely the number of exit edges of  $X$  in  $G$ .

**Fact 1** *For any  $X \subseteq V(G)$  we have  $\psi_G(X) = \xi_G(X) + 2n_0(G - X)$ .*

**Proof.** If  $v$  is not isolated in  $G - X$ , then  $\omega_{G-X}(v) - \omega_G(v)$  is precisely the number of exit edges of  $X$  incident with  $v$  in  $G$ . In the case that  $v$  is isolated in  $G - X$ , we have  $\omega_{G-X}(v) - \omega_G(v)$  is the number of exit edges of  $X$  incident with  $v$  in  $G$  plus an additional 2.  $\square$

The next fact relates the difference between the weight of  $X$  in  $G$  and the cost of removing  $X$  from  $G$  to the number of additional vertices required to turn a minimum ID-set of  $G - X$  into an ID-set of  $G$ .

**Fact 2** Let  $X \subseteq V(G)$ , let  $G' = G - X$ , and let  $S'$  be an  $i(G')$ -set. If there exist a set  $S$  such that  $S' \cup S$  is an ID-set of  $G$ , then  $\omega_G(X) - \psi_G(X) < 8|S|$ .

**Proof.** Suppose  $S' \cup S$  is an ID-set of  $G$ . Since  $G$  is a counterexample to Theorem 3 we have  $\omega(G) < 8i(G)$ . Since  $S' \cup S$  is an ID-set of  $G$  and by the minimality of  $G$  it follows that

$$\omega(G) < 8i(G) \leq 8i(G') + 8|S| \leq \omega(G') + 8|S| = \omega(G) - \omega_G(X) + \psi_G(X) + 8|S|,$$

and the desired result follows.  $\square$

We are now ready to prove our main result. In what follows we present a series of claims describing some structural properties of  $G$  which culminate in the implication of its non-existence.

**Claim 3.1** No vertex in  $G$  has two neighbors of degree 1.

**Proof.** For the sake of contradiction, suppose  $G$  contains such a vertex  $x$ . Since  $G$  has at least four vertices,  $d_G(x) = 3$ . Let  $N_G(x) = \{x_1, x_2, x_3\}$  where  $d_G(x_1) = d_G(x_2) = 1$ . We remark that  $d_G(x_3) \in \{1, 2, 3\}$ . [See Figure 3.] Let  $V' = N_G[x]$ , let  $G' = G - V'$  and let  $S'$  be an  $i(G')$ -set. Note that  $\omega_G(x_3) \in \{3, 4, 5\}$ , and so  $\omega_G(V') = \omega_G(x) + \omega_G(x_1) + \omega_G(x_2) + \omega_G(x_3) \geq 3 + 5 + 5 + 3 = 16$ . Note further that  $V'$  has at most two exit edges in  $G$  and so  $G'$  contains at most two isolated vertices. Therefore, by Fact 1, we have that the cost of removing  $V'$  from  $G$  is:  $\psi_G(V') = \xi_G(V') + 2n_0(G') \leq 2 + 4 = 6$ . Consequently,  $\omega_G(V') - \psi_G(V') \geq 16 - 6 = 10$ . But  $S' \cup \{x\}$  is an ID-set of  $G$  and so by Fact 2 we have  $\omega_G(V') - \psi_G(V') < 8$ , a contradiction.  $\square$

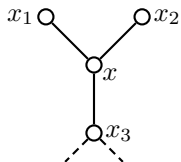

Figure 3: The vertices in  $N_G[x]$  and their possible incident edges.

**Claim 3.2** *If  $v \in V(G)$  such that  $d_G(v) = 2$ , then  $v$  has no neighbors of degree 1 in  $G$ .*

**Proof.** Suppose for the sake of contradiction that  $v \in V(G)$  such that  $d_G(v) = 2$  and  $v$  has a degree 1 neighbor,  $u$  say, in  $G$ . Let  $N_G(v) = \{u, w\}$  and note that  $d_G(w) \geq 2$  by Claim 3.1. [See Figure 4.] Let  $V' = \{u, v\}$ , let  $G' = G - V'$  and let  $S'$  be an  $i(G')$ -set. We note that  $\omega_G(V') = \omega_G(u) + \omega_G(v) = 5 + 4 = 9$ . We note further that  $V'$  has exactly one exit edge in  $G$ , namely  $vw$ , and since  $d_G(w) \geq 2$  we have that  $G'$  contains no isolated vertices. Therefore, by Fact 1,  $\psi_G(V') = \xi_G(V') = 1$ . Consequently,  $\omega_G(V') - \psi_G(V') = 9 - 1 = 8$ . But  $S' \cup \{u\}$  is an  $ID$ -set of  $G$  and so by Fact 2 we have  $\omega_G(V') - \psi_G(V') < 8$ , a contradiction.  $\square$

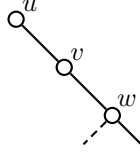

Figure 4: The vertices  $u, v, w$  and their possible incident edges.

**Claim 3.3** *No vertex in  $G$  has degree 1.*

**Proof.** Suppose for the sake of contradiction that  $G$  contains a vertex of degree 1. Let  $P : v_1 \dots v_k$  be the longest path in  $G$  such that for all  $i \in \{1, \dots, k\}$ ,  $v_i$  is adjacent to a degree 1 vertex,  $u_i$  say. Possibly,  $k = 1$ . By Claim 3.2,  $d_G(v_i) = 3$  for all  $i \in \{1, \dots, k\}$ . If  $v_1 v_k \in E(G)$ , then  $G = G[N_G[P]]$  is the corona of a cycle of length  $k$  and  $\{u_1, \dots, u_k\}$  is an  $i(G)$ -set. It follows that  $8i(G) = 8k = (5 + 3)k = \omega(G)$ , a contradiction. Hence,  $v_1 v_k \notin E(G)$ . If  $k = 1$ , let  $N_G(v_1) = \{a, b, u_1\}$ , otherwise let  $N_G(v_1) = \{a, u_1, v_2\}$  and let  $N_G(v_k) = \{b, u_k, v_{k-1}\}$ . Since  $v_1 v_k \notin E(G)$ , we have that  $a \neq v_k$  and  $b \neq v_1$ . Let  $V' = (\cup_{i=1}^k \{u_i, v_i\} \cup \{a\})$ , let  $G' = G - V'$  and let  $S'$  be an  $i(G')$ -set.

Suppose  $a = b$ . We observe that  $d_G(a) \neq 2$ , otherwise  $G = G[N_G[P]]$  and  $(\cup_{i=2}^k \{u_i\} \cup \{v_1\})$  is an  $i(G)$ -set and it then follows that  $8i(G) = 8k < (5 + 3)k + 4 = \omega(G)$ , contradicting the choice of  $G$ . Thus,  $d_G(a) = 3$ . Let  $N_G(a) = \{a', v_1, v_k\}$ . [See Figure 5A.] We note that  $\omega_G(V') = (5 + 3)k + 3 = 8k + 3$ . We note further that  $V'$  has exactly one exit edge in  $G$ , namely  $aa'$ . Furthermore, by our choice of  $P$ ,  $d_G(a') > 1$  and so  $d_{G'}(a') > 0$ . Thus  $G'$  contains no isolated vertices and so, by Fact 1,  $\psi_G(V') = \xi_G(V') = 1$ . Consequently,  $\omega_G(V') - \psi_G(V') = 8k + 3 - 1 = 8k + 2$ . But  $S' \cup (\cup_{i=2}^k \{u_i\} \cup \{v_1\})$  is an  $ID$ -set of  $G$  and so by Fact 2 we have  $\omega_G(V') - \psi_G(V') < 8k$ , a contradiction. Hence,  $a \neq b$ . [See Figure 5B.] Relabeling vertices if necessary, we may assume that  $d_G(a) \leq d_G(b)$ . Hence, by Claim 3.1, we have  $2 \leq d_G(a) \leq d_G(b)$ .

We now note that  $\omega_G(V') = (5 + 3)k + \omega_G(a) \geq 8k + 3$ . We note further that  $V'$  has at most three exit edges in  $G$ . Suppose  $G'$  has an isolated vertex,  $z$  say. By Claim 3.1 and maximality of  $P$ ,  $d_G(z) > 1$ , and necessarily  $N_G(z) = \{a, v_k\}$  and so  $z = b$ . Furthermore, since  $d_G(a) \leq d_G(b)$ ,  $d_G(a) = 2$  and so  $G = G[N_G[P]]$  and  $(\cup_{i=1}^k \{u_i\} \cup \{a\})$  is an  $i(G)$ -set. But now it follows that  $8i(G) = 8(k + 1) = (5 + 3)k + 4 + 4 = \omega(G)$ , contradicting the choice of

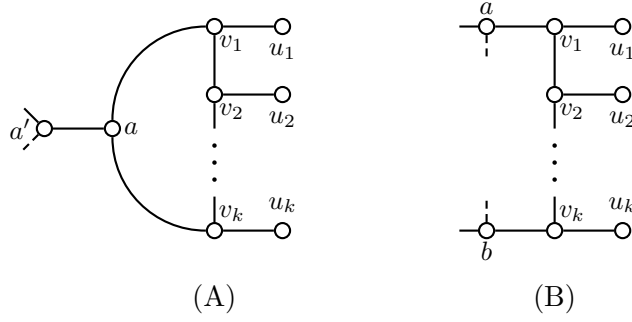

Figure 5: Illustrations for Claim 3.3.

$G$ . Thus,  $G'$  has no isolated vertices and so, by Fact 1,  $\psi_G(V') = \xi_G(V') \leq 3$ . Consequently,  $\omega_G(V') - \psi_G(V') \geq 8k + 3 - 3 = 8k$ . But  $S' \cup (\cup_{i=2}^k \{u_i\} \cup \{v_1\})$  is an  $ID$ -set of  $G$  and so by Fact 2 we have  $\omega_G(V') - \psi_G(V') < 8k$ , a contradiction.  $\square$

**Claim 3.4** *The graph  $G$  does not contain a path  $uvw$  such that  $d_G(u) = d_G(v) = d_G(w) = 2$ .*

**Proof.** Suppose for the sake of contradiction that  $G$  contains such a path,  $uvw$ . [See Figure 6A.] Let  $V' = \{u, v, w\}$ , let  $G' = G - V'$  and let  $S'$  be an  $i(G')$ -set. We note that  $\omega_G(V') = \omega_G(u) + \omega_G(v) + \omega_G(w) = 4 + 4 + 4 = 12$ . We note further that  $V'$  has exactly two exit edges in  $G$ . By Claim 3.3,  $u$  and  $w$  have no degree 1 neighbors in  $G$  and so  $G'$  contains at most one isolated vertex, and only if  $G = C_4$ . Therefore, by Fact 1,  $\psi_G(V') = \xi_G(V') + 2n_0(G') \leq 2 + 2 = 4$ . Consequently,  $\omega_G(V') - \psi_G(V') \geq 12 - 4 = 8$ . But  $S' \cup \{v\}$  is an  $ID$ -set of  $G$  and so by Fact 2 we have  $\omega_G(V') - \psi_G(V') < 8$ , a contradiction.  $\square$

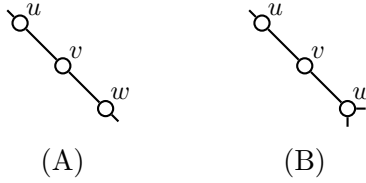

Figure 6: The vertices  $u, v, w$  and their incident edges.



**Claim 3.5** *No two adjacent vertices in  $G$  both have degree 2.*

**Proof.** Suppose for the sake of contradiction that  $G$  contains two adjacent degree 2 vertices,  $u$  and  $v$  say. Let  $N_G(v) = \{u, w\}$  and note that by Claims 3.3 and 3.4 we have  $d_G(w) = 3$ . [See Figure 6B.] Let  $V' = \{u, v, w\}$ , let  $G' = G - V'$  and let  $S'$  be an  $i(G')$ -set. We note that  $\omega_G(V') = \omega_G(u) + \omega_G(v) + \omega_G(w) = 4 + 4 + 3 = 11$ . We note further that  $V'$  has at most three exit edges in  $G$ . By Claim 3.3,  $u$  and  $w$  have no degree 1 neighbors in  $G$  and, by Claim 3.4,  $u$  has no degree 2 neighbor different from  $v$  and so  $G'$  contains no isolated vertices. Therefore, by Fact 1,  $\psi_G(V') = \xi_G(V') \leq 3$ . Consequently,  $\omega_G(V') - \psi_G(V') \geq 11 - 3 = 8$ . But  $S' \cup \{v\}$  is an  $ID$ -set of  $G$  and so by Fact 2 we have  $\omega_G(V') - \psi_G(V') < 8$ , a contradiction.  $\square$

**Claim 3.6** *A degree 3 vertex of  $G$  is adjacent to at most one degree 2 vertex.*

**Proof.** Suppose for the sake of contradiction that  $G$  contains a degree 3 vertex,  $v$  say, that is adjacent to at least two degree 2 vertices. [See Figure 7.] Let  $V' = N_G[v]$ , let  $G' = G - V'$  and let  $S'$  be an  $i(G')$ -set. We note that  $\omega_G(V') \geq 3 + 4 + 4 + 3 = 14$  and that  $V'$  has at most four exit edges in  $G$ . Suppose  $G'$  contains an isolated vertex,  $u$  say. By Claim 3.3, we have  $d_G(u) \geq 2$ . If  $d_G(u) = 3$ , then  $G$  contains  $K_{2,3}$  as a subgraph, contradicting the choice of  $G$ , and if  $d_G(u) = 2$ , then  $G$  contains two adjacent degree 2 vertices, contradicting Claim 3.5. Thus,  $G'$  contains no isolated vertices and so, by Fact 1,  $\psi_G(V') = \xi_G(V') \leq 4$ . Consequently,  $\omega_G(V') - \psi_G(V') \geq 14 - 4 = 10$ . But  $S' \cup \{v\}$  is an  $ID$ -set of  $G$  and so by Fact 2 we have  $\omega_G(V') - \psi_G(V') < 8$ , a contradiction.  $\square$

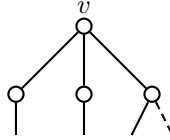

Figure 7: The vertices in  $N_G[v]$  and their possible incident edges.

**Claim 3.7** *The graph  $G$  is cubic.*

**Proof.** Suppose for the sake of contradiction that there exists a vertex of degree 2 in  $G$ ,  $u$  say. By Claim 3.5, both the neighbors of  $u$  have degree 3 in  $G$ . Let  $v \in N_G(u)$  and let  $N_G(v) = \{u, x, y\}$ . By Claim 3.6,  $d_G(x) = d_G(y) = 3$ . [See Figure 8A.] Let  $V' = N_G[v]$ , let  $G' = G - V'$  and let  $S'$  be an  $i(G')$ -set. Now,  $\xi_G(V') \leq 5$ . If  $G'$  contains no isolated vertices, then by Fact 1 we have  $\psi_G(V') = \xi_G(V') \leq 5$ , and so  $\omega_G(V') - \psi_G(V') \geq 3 + 3 + 3 + 4 - 5 = 8$ . But  $S' \cup \{v\}$  is an  $ID$ -set of  $G$  and so by Fact 2 we have  $\omega_G(V') - \psi_G(V') < 8$ , a contradiction.

Hence,  $G'$  contains an isolated vertex,  $w$  say. Since  $G$  contains no  $K_{2,3}$  as a subgraph, we have  $N_G(w) \neq \{u, x, y\}$ . Therefore, by Claim 3.3 we have  $d_G(w) = 2$  and by Claim 3.5 we have  $N_G(w) = \{x, y\}$ . Let  $N_G(x) = \{s, v, w\}$  and  $N_G(y) = \{t, v, w\}$ . Since  $G$  contains no  $K_{2,3}$  as a

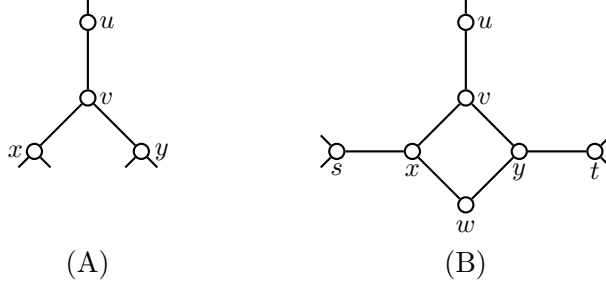

Figure 8: Illustrations for Claim 3.7.

subgraph,  $s \neq t$ . By Claim 3.6 we have  $d_G(s) = d_G(t) = 3$ . [See Figure 8B.] Since  $d_G(u) = 2$  and  $uv \in E(G)$  we have  $\{su, tu\} \not\subseteq E(G)$ . Relabeling vertices if necessary, we may assume that  $su \notin E(G)$ .

Let  $V'' = N_G[x]$ , let  $G'' = G - V''$  and let  $S''$  be an  $i(G'')$ -set. Suppose that  $G''$  contains an isolated vertex,  $z$  say. Since  $G$  contains no  $K_{2,3}$  as a subgraph, we have  $N_G(z) \neq \{s, v, w\}$ . Therefore, by Claim 3.3 we have  $d_G(z) = 2$ , and since  $d_G(y) = 3$  we have  $z \neq y$ . But then  $N_G(z) = \{s, v\}$  and  $z = u$ , contradicting the fact that  $su \notin E(G)$ . Thus,  $G''$  contains no isolated vertices and so by Fact 1 we have  $\psi_G(V'') = \xi_G(V'') \leq 5$ . Therefore,  $\omega_G(V'') - \psi_G(V'') \geq 3+3+3+4-5 = 8$ . But  $S'' \cup \{x\}$  is an  $ID$ -set of  $G$  and so by Fact 2 we have  $\omega_G(V'') - \psi_G(V'') < 8$ , a contradiction.  $\square$

**Claim 3.8**  $G$  contains no  $C_3$ .

**Proof.** Suppose for the sake of contradiction that  $G$  contains a triangle,  $uvw$  say. Let  $N_G(u) = \{v, w, x\}$ , let  $V' = N_G[u]$ , let  $G' = G - V'$  and let  $S'$  be an  $i(G')$ -set. [See Figure 9.]

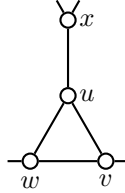

Figure 9: The vertices  $u, v, w, x$  and their incident edges.

We observe that  $\xi_G(V') \leq 4$ . If  $G'$  contains an isolated vertex,  $y$  say, then  $N_G(u) = N_G(y)$ , contradicting the fact that  $G$  does not contain  $K_{2,3}$  as a subgraph. Thus,  $G'$  contains no isolated vertices and so by Fact 1 we have  $\psi_G(V') \leq 4$ . Therefore  $\omega_G(V') - \psi_G(V') \geq 4 \cdot 3 - 4 = 8$ . But  $S' \cup \{u\}$  is an  $ID$ -set of  $G$  and so by Fact 2 we have  $\omega_G(V') - \psi_G(V') < 8$ , a contradiction.  $\square$

**Claim 3.9** Any two distinct 4-cycles in  $G$  have no edges in common.

**Proof.** Suppose for the sake of contradiction that  $G$  contains two distinct 4-cycles in  $G$ ,  $C_1$  and  $C_2$  say, with at least one common edge. Clearly  $C_1$  and  $C_2$  have at most two edges in common. If  $C_1$  and  $C_2$  have two edges in common, then either  $G = K_4$  contradicting Claim 3.8, or these edges are adjacent and  $G$  contains  $K_{2,3}$  as a subgraph, a contradiction. Let  $C_1 = abcd$  and  $C_2 = cdef$ . [See Figure 10A.]

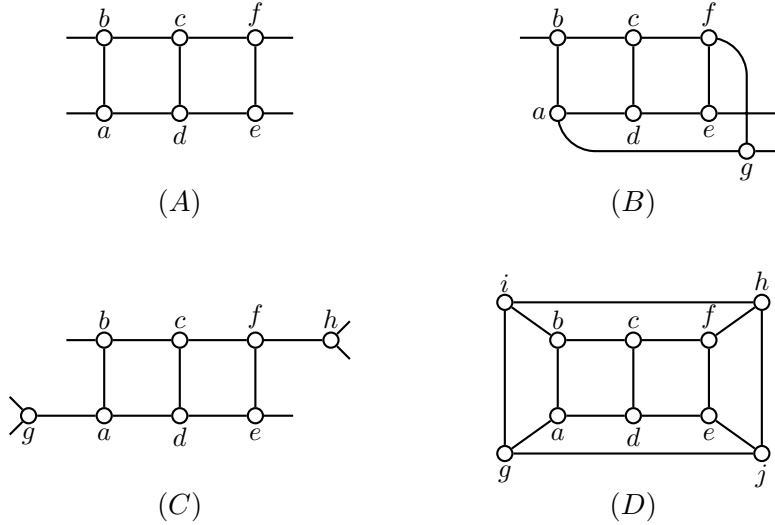

Figure 10: Illustrations for Claim 3.9.

By Claim 3.8, we have  $\{ac, ae, ce, bd, bf, df\} \cap E(G) = \emptyset$  and since  $G$  does not contain  $K_{2,3}$  as a subgraph,  $af \notin E(G)$  and  $be \notin E(G)$ . Let  $N_G(a) = \{b, d, g\}$  and  $N_G(f) = \{c, e, h\}$  (possibly,  $g = h$ , but neither  $g$  nor  $h$  is equal to one of  $a, b, c, d, e, f$ ). Let  $V' = \{a, b, c, d, e, f, g\} \cup \{h\}$ , let  $G' = G - V'$  and let  $S'$  be an  $i(G')$ -set. Then  $S' \cup \{a, f\}$  is an ID-set of  $G$  of cardinality  $i(G') + 2$  and so, by Fact 2, we have  $\omega_G(V') - \psi_G(V') < 16$ . If  $g = h$ , then  $\xi_G(V') \leq 3$  and so there is at most one isolated vertex in  $G'$ . By Fact 1, we have  $\psi_G(V') \leq 5$ . [See Figure 10B.] But then  $\omega_G(V') - \psi_G(V') \geq 7 \cdot 3 - 5 = 16$ , a contradiction. Hence,  $g \neq h$ . Now  $\xi_G(V') \leq 6$ . [See Figure 10C.] If  $G'$  contains no more than one isolated vertex, then  $\psi_G(V') \leq 8$ . But then  $\omega_G(V') - \psi_G(V') \geq 8 \cdot 3 - 8 = 16$ , a contradiction. Hence,  $G'$  contains two isolated vertices,  $i$  and  $j$  say, and  $N_G(\{i, j\}) = \{b, e, g, h\}$ . Relabeling vertices if necessary, we may assume that  $N_G(i) = \{b, g, h\}$  and  $N_G(j) = \{e, g, h\}$ . [See Figure 10D.] But now  $G = C_5 \square K_2$ , a contradiction.  $\square$

**Claim 3.10**  $G$  contains no  $C_4$ .

**Proof.** Suppose for the sake of contradiction that  $G$  contains a 4-cycle,  $abcd$  say. Let  $N_G(a) = \{b, d, e\}$  and  $N_G(c) = \{b, d, f\}$ . Since  $G$  does not contain  $K_{2,3}$  as a subgraph, we have  $e \neq f$ . Let

$N_G(e) = \{a, g, h\}$ . We note that possibly  $f \in \{g, h\}$  but by Claim 3.8 we have  $\{b, d\}$  and  $\{g, h\}$  are disjoint. Let  $V_1 = N_G[\{e, c\}]$ , let  $G_1 = G - V_1$  and let  $S_1$  be an  $i(G_1)$ -set. We note that  $S_1 \cup \{e, c\}$  is an  $ID$ -set of  $G$  and so by Fact 2 we have  $\omega_G(V_1) - \psi_G(V_1) < 16$ .

Suppose  $f \in \{g, h\}$ . We may assume, relabeling vertices if necessary, that  $f = g$ . [See Figure 11A.] We observe that  $\xi_G(V_1) \leq 5$ . If  $G_1$  contains an isolated vertex,  $x$  say, then necessarily  $|N_G(x) \cap \{b, d, f\}| \geq 2$ . If  $f \in N_G(x)$ , then  $G$  contains two adjacent 4-cycles, contradicting Claim 3.9. But then  $\{b, d\} \subseteq N_G(x)$  and  $G$  contains  $K_{2,3}$  as a subgraph, another contradiction. Hence,  $G_1$  contains no isolated vertices and so by Fact 1 we have  $\psi_G(V_1) \leq 5$ . Therefore  $\omega_G(V_1) - \psi_G(V_1) \geq 7 \cdot 3 - 5 = 16$ , a contradiction. Hence,  $f \notin \{g, h\}$ . [See Figure 11B.]

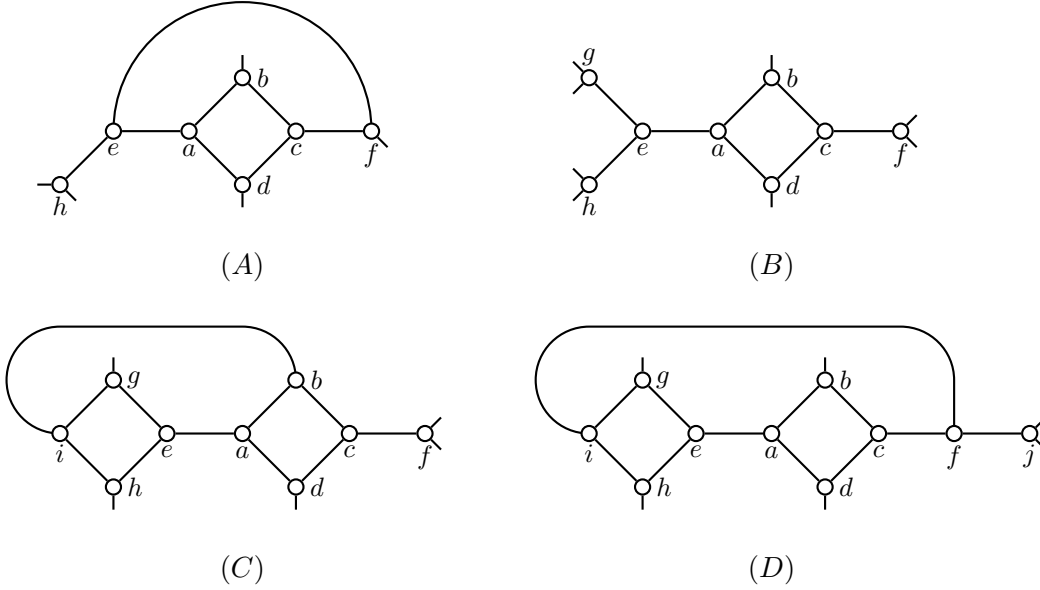

Figure 11: Illustrations for Claim 3.10.

We now observe that  $\xi_G(V_1) \leq 8$ . If  $G_1$  contains no isolated vertices, then by Fact 1 we have  $\psi_G(V_1) \leq 8$ . But then  $\omega_G(V_1) - \psi_G(V_1) \geq 8 \cdot 3 - 8 = 16$ , a contradiction. Hence,  $G_1$  contains an isolated vertex,  $i$  say. Necessarily  $|N_G(i) \cap \{b, d, f\}| = 1$ , since it is bound above by the fact that  $G$  contains no adjacent 4-cycles or  $K_{2,3}$  and bound below by the availability of neighbors for  $i$ .

Suppose  $N_G(i) \cap \{b, d\} \neq \emptyset$ . We may assume, relabeling vertices if necessary, that  $N_G(i) = \{b, g, h\}$ . [See Figure 11C.] Let  $V_2 = N_G[\{a, i\}]$ , let  $G_2 = G - V_2$  and let  $S_2$  be an  $i(G_2)$ -set. We note that  $S_2 \cup \{a, i\}$  is an  $ID$ -set of  $G$  and so by Fact 2 we have  $\omega_G(V_2) - \psi_G(V_2) < 16$ . Observe that  $\xi_G(V_2) \leq 5$ . If  $G_2$  contains an isolated vertex,  $y$  say, then  $N_G(y) = \{d, g, h\}$ , since  $y \neq c$ . But then  $G$  contains  $K_{2,3}$  as a subgraph, a contradiction. Therefore  $G_2$  contains no isolated vertices and by Fact 1 we have  $\psi_G(V_2) \leq 5$ . But then  $\omega_G(V_2) - \psi_G(V_2) \geq 7 \cdot 3 - 5 = 16$ , a contradiction. Thus,  $N_G(i) \cap \{b, d\} = \emptyset$  and so  $N_G(i) = \{f, g, h\}$ .

Let  $N_G(f) = \{c, i, j\}$  and note that since  $G$  contains no 3-cycles we have  $j \notin \{b, d, g, h\}$ . [See Figure 11D.] Let  $V_3 = N_G[\{e, f\}]$ , let  $G_3 = G - V_3$  and let  $S_3$  be an  $i(G_3)$ -set. We note that

$S_3 \cup \{e, f\}$  is an *ID*-set of  $G$  and so by Fact 2 we have  $\omega_G(V_3) - \psi_G(V_3) < 16$ . Observe that  $\xi_G(V_3) \leq 8$ . Suppose  $G_3$  contains an isolated vertex,  $z$  say. Since  $G$  does not contain  $K_{2,3}$  as a subgraph, we have  $N_G(z) \neq \{g, h, j\}$ . But then  $z \in \{b, d\}$  and  $N_G(z) = \{a, c, z'\}$  where  $z' \in \{g, h, j\}$ . But now  $G$  contains two adjacent 4-cycles, contradicting Claim 3.9. Therefore  $G_3$  contains no isolated vertices and by Fact 1 we have  $\psi_G(V_3) \leq 8$ . But then  $\omega_G(V_3) - \psi_G(V_3) \geq 8 \cdot 3 - 8 = 16$ , a contradiction.  $\square$

**Claim 3.11**  $G$  contains no  $C_6$ .

**Proof.** Suppose for the sake of contradiction that  $G$  contains a 6-cycle,  $abcdef$  say. Let  $N_G(a) = \{b, f, g\}$  and  $N_G(d) = \{c, e, h\}$ . We note that possibly  $g = h$  but by Claims 3.8 and 3.10, we have  $\{a, b, c, d, e, f\}$  and  $\{g, h\}$  are disjoint. Let  $V' = N_G[\{a, d\}]$ , let  $G' = G - V'$  and let  $S'$  be an  $i(G')$ -set. We note that  $S' \cup \{a, d\}$  is an *ID*-set of  $G$  and so by Fact 2 we have  $\omega_G(V') - \psi_G(V') < 16$ .

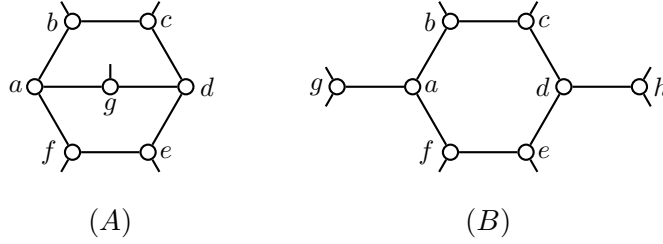

Figure 12: The vertices  $a, b, c, d, e, f, g, h$  and their incident edges.

By Claim 3.10,  $G$  contains no  $C_4$ , and so any isolated vertex in  $G'$  is necessarily adjacent to at most one vertex from  $\{b, f, g\}$  and at most one vertex from  $\{c, e, h\}$ . Hence by Claim 3.7,  $G'$  contains no isolated vertices. If  $g = h$  [Figure 12A], then  $\xi_G(V') \leq 5$  and so by Fact 1 we have  $\psi_G(V') \leq 5$  and therefore  $\omega_G(V') - \psi_G(V') \geq 7 \cdot 3 - 5 = 16$ , a contradiction. On the other hand, if  $g \neq h$  [Figure 12B], then  $\psi_G(V') = \xi_G(V') \leq 8$  and so  $\omega_G(V') - \psi_G(V') \geq 8 \cdot 3 - 8 = 16$ , another contradiction.  $\square$

**Claim 3.12** Any two distinct 5-cycles in  $G$  have no edges in common.

**Proof.** Suppose for the sake of contradiction that  $G$  contains two distinct 5-cycles in  $G$ ,  $C_1$  and  $C_2$  say, with at least one common edge. Clearly  $C_1$  and  $C_2$  have at most three edges in common. If  $C_1$  and  $C_2$  have three edges in common, then  $G$  contains a 4-cycle, a contradiction. If  $C_1$  and  $C_2$  have two edges in common, then these edges are either adjacent and  $G$  contains a 6-cycle, contradicting Claim 3.11, or they are nonadjacent and  $G$  contains a 3-cycle, contradicting Claim 3.8. Therefore,  $C_1$  and  $C_2$  have at most one edge in common. Let  $C_1 = u_1u_2u_3u_4u_5$  and  $C_2 = u_4u_5u_6u_7u_8$ . Let  $N_G(u_1) = \{u_2, u_5, v_1\}$ , let  $N_G(u_3) = \{u_2, u_4, v_3\}$  and let  $N_G(u_7) = \{u_6, u_8, v_7\}$ . By Claims 3.8, 3.10 and 3.11 we have that  $\{v_1, v_3, v_7\} \cap \{u_1, \dots, u_8\} = \emptyset$  and furthermore that  $v_1, v_3$  and  $v_7$  are all distinct. [See Figure 13.]

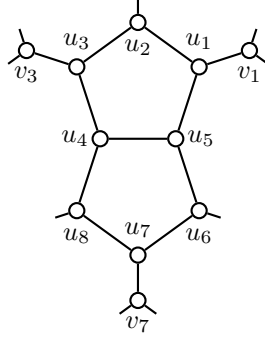

Figure 13: The vertices  $u_1, \dots, u_8, v_1, v_3, v_7$  and their incident edges.

Let  $V' = N_G[\{u_1, u_3, u_7\}]$ , let  $G' = G - V'$  and let  $S'$  be an  $i(G')$ -set. Suppose there is an isolated vertex,  $w$  say, in  $G'$ . Since  $G$  contains no 4-cycles, we have  $|N_G(w) \cap \{u_2, v_1\}| \leq 1$ ,  $|N_G(w) \cap \{u_2, v_3\}| \leq 1$  and  $|N_G(w) \cap \{u_6, u_8, v_7\}| \leq 1$ . And since these sets exhaust all possible neighbors of  $w$  in  $G$  we have equality in each case. Necessarily then  $u_2 \notin N_G(w)$  and so  $\{v_1, v_3\} \subseteq N_G(w)$ . But now  $G$  contains a 6-cycle, a contradiction. Hence,  $G'$  contains no isolated vertices and so, by Fact 1, we have  $\psi_G(V') = \xi_G(V') \leq 9$ . Therefore  $\omega_G(V') - \psi_G(V') \geq 11 \cdot 3 - 9 = 24$ . But  $S' \cup \{u_1, u_3, u_7\}$  is an  $ID$ -set of  $G$  and so by Fact 2 we have  $\omega_G(V') - \psi_G(V') < 24$ , a contradiction.  $\square$

**Claim 3.13** *The girth of  $G$  is at least 7.*

**Proof.** By Claims 3.8 and 3.10 we have  $g(G) \geq 5$  and therefore, by Claim 3.11, it suffices to show that  $G$  contains no  $C_5$ . Suppose for the sake of contradiction that  $G$  contains a 5-cycle,  $u_1 u_2 u_3 u_4 u_5$  say.

For  $i \in \{3, 4\}$ , let  $N_G(u_i) = \{u_{i-1}, u_{i+1}, v_i\}$  and let  $N_G(v_i) = \{u_i, v'_i, v''_i\}$ . We note that by Claim 3.12 we have  $\{v'_3, v''_3\} \cap \{v'_4, v''_4\} = \emptyset$  and by Claims 3.8 and 3.10 we have  $\{v'_3, v''_3, v'_4, v''_4\} \cap \{u_1, u_2, u_5\} = \emptyset$ . Let  $N_G(u_1) = \{u_2, u_5, v_1\}$  and note that by Claim 3.12 we have  $v_1 \notin \{v'_3, v''_3, v'_4, v''_4\}$ . [See Figure 14A.]

Let  $V_1 = N_G[\{u_1, v_3, v_4\}]$ , let  $G_1 = G - V_1$  and let  $S_1$  be an  $i(G_1)$ -set. We note that  $S_1 \cup \{u_1, v_3, v_4\}$  is an  $ID$ -set of  $G$  and so by Fact 2 we have  $\omega_G(V_1) - \psi_G(V_1) < 24$ . We note that  $\omega_G(V_1) = 3|V_1| = 36$ . If  $G_1$  contains no isolated vertices, then by Fact 1 we have  $\psi_G(V_1) = \xi_G(V_1) \leq 12$  and so  $\omega_G(V_1) - \psi_G(V_1) \geq 36 - 12 = 24$ , a contradiction. Hence,  $G_1$  contains an isolated vertex,  $v'_1$  say. By Claims 3.10 and 3.12 we have that  $v'_1$  is adjacent to  $v_1$  and exactly one neighbor of  $v_3$  and one neighbor of  $v_4$ . Relabeling vertices if necessary, we may assume that  $N_G(v'_1) = \{v_1, v'_3, v'_4\}$ . Let  $v''_1$  be the third neighbor of  $v_1$ . By Claims 3.8 and 3.11 we have that  $v''_1 \notin \{u_2, u_5, v'_3, v''_3, v'_4, v''_4\}$ . [See Figure 14B.]

Let  $V_2 = N_G[\{v_1, v_3, v_4\}]$ , let  $G_2 = G - V_2$  and let  $S_2$  be an  $i(G_2)$ -set. We note that  $S_2 \cup \{v_1, v_3, v_4\}$  is an  $ID$ -set of  $G$  and so by Fact 2 we have  $\omega_G(V_2) - \psi_G(V_2) < 24$ . We note that

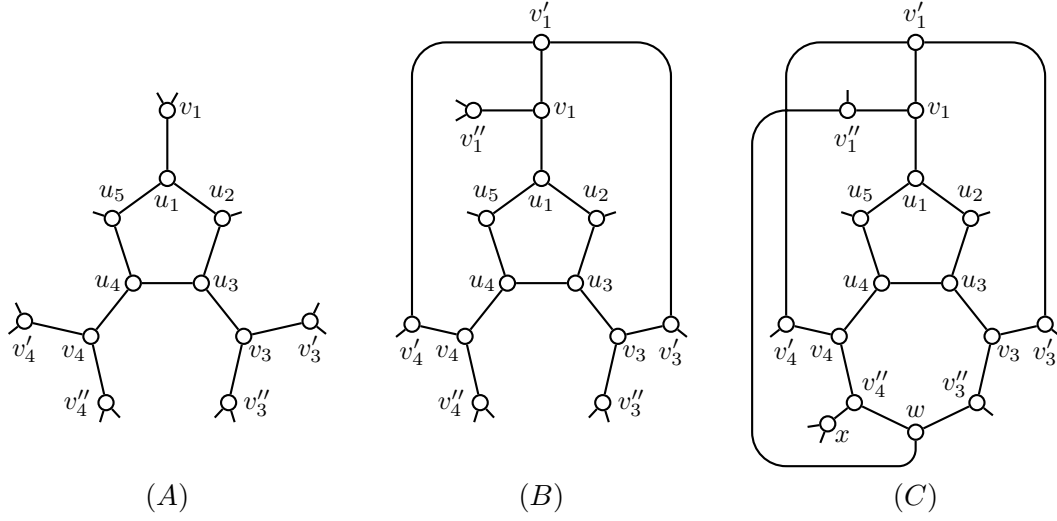

Figure 14: Illustrations for Claim 3.13.

$\omega_G(V_2) = 3|V_2| = 36$ . If  $G_2$  contains no isolated vertices, then by Fact 1 we have  $\psi_G(V_2) = \xi_G(V_2) \leq 12$  and so  $\omega_G(V_2) - \psi_G(V_2) \geq 36 - 12 = 24$ , a contradiction. Hence,  $G_2$  contains an isolated vertex,  $w$  say. We note that by Claim 3.10 and Claim 3.12 we have  $w \notin \{u_2, u_5\}$ . Hence,  $N_G(w) \subseteq \{v''_1, v'_3, v''_3, v'_4, v''_4\}$ . By Claim 3.10 we have that  $w$  is adjacent to exactly one vertex in  $\{v'_3, v''_3\}$  and exactly one vertex in  $\{v'_4, v''_4\}$ . If  $wv'_3 \in E(G)$ , then  $wv'_4 \in E(G)$  produces a 4-cycle in  $G$  and  $wv''_4 \in E(G)$  produces a 6-cycle in  $G$ , contradicting Claims 3.10 and 3.11 respectively. Therefore,  $wv'_3 \notin E(G)$  and, analogously,  $wv'_4 \notin E(G)$ . Consequently,  $N_G(w) = \{v''_1, v''_3, v''_4\}$ . Let  $x$  be the third neighbor of  $v''_4$ . By Claims 3.8, 3.10, 3.12 and 3.12 we have that  $x \notin \{u_2, u_5, v''_1, v'_3, v''_3, v'_4\}$ . [See Figure 14C.]

Let  $V_3 = N_G[\{v_1, v_3, v''_4\}]$ , let  $G_3 = G - V_3$  and let  $S_3$  be an  $i(G_3)$ -set. We note that  $\omega_G(V_3) = 3|V_3| = 36$ . Suppose  $G_3$  contains an isolated vertex,  $z$  say. Clearly,  $z \notin \{u_4, u_5\}$  since  $u_4u_5 \in E(G_3)$ . If  $z \in \{u_2, v'_4\}$ , then  $|N_G(z) \cap \{v''_1, v'_3, v''_3, x\}| = 1$  and  $G$  contains a 4-cycle or 6-cycle, contradicting Claims 3.10 or 3.11 respectively. Hence,  $N_G(z) \subseteq \{v''_1, v'_3, v''_3, x\}$ . But  $|N_G(z) \cap \{v''_1, v'_3, v''_3\}| \leq 1$  otherwise, again,  $G$  contains a 4-cycle or 6-cycle. Thus,  $G_3$  contains no isolated vertices. Consequently, by Fact 1, we have  $\psi_G(V_3) = \xi_G(V_3) \leq 12$  and so  $\omega_G(V_3) - \psi_G(V_3) \geq 36 - 12 = 24$ . But  $S_3 \cup \{v_1, v_3, v''_4\}$  is an  $ID$ -set of  $G$  and so by Fact 2 we have  $\omega_G(V_3) - \psi_G(V_3) < 24$ , a contradiction.  $\square$

**Claim 3.14** *The girth of  $G$  is at least 8.*

**Proof.** By Claim 3.13 we have  $g(G) \geq 7$  and so it suffices to show that  $G$  contains no 7-cycle. Suppose for the sake of contradiction that  $G$  contains a 7-cycle,  $C : u_0u_1 \dots u_6$  say. For  $i \in \{0, \dots, 6\}$  let  $v_i$  be the neighbor of  $u_i$  not on  $C$  and let  $N_G(v_i) = \{u_i, w'_i, w''_i\}$ . Since  $g(G) \geq 7$  we note that if  $\{i, j\} \subseteq \{0, \dots, 6\}$ , then  $v_i \neq v_j$  and  $\{w'_i, w''_i\} \cap \{v_0, \dots, v_6\} = \emptyset$ . Possibly  $\{w'_i, w''_i\} \cap \{w'_j, w''_j\} \neq \emptyset$ , but only if  $i - j \equiv 3, 4 \pmod{7}$ .

For convenience, in the rest of this proof, subscripts are taken modulo 7. Consider the set  $V_i = \{v_i, u_{i-2}, u_{i+2}\}$ . [See Figure 15A.]

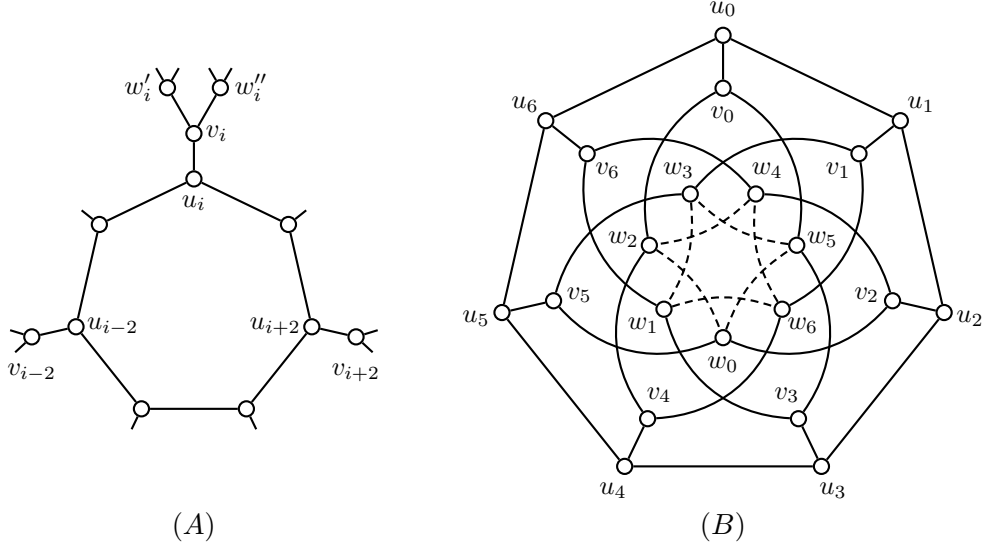

Figure 15: Illustrations for Claim 3.14.

Let  $V'_i = N_G[V_i]$ , let  $G'_i = G - V'_i$  and let  $S'_i$  be an  $i(G'_i)$ -set. Since  $S'_i \cup V_i$  is an  $ID$ -set of  $G$  we have, by Fact 2, that  $\omega_G(V'_i) - \psi_G(V'_i) < 8 \cdot 3 = 24$ . We now observe that  $|V'_i| = 12$  and therefore  $\omega_G(V'_i) = 3|V'_i| = 36$ . We observe further that  $\xi_G(V'_i) = 12$ . If  $G'_i$  contains no isolated vertices, then by Fact 1 we have  $\psi_G(V'_i) = \xi_G(V'_i) \leq 12$  and so  $\omega_G(V'_i) - \psi_G(V'_i) \geq 36 - 12 = 24$ , a contradiction. Hence,  $G'_i$  contains an isolated vertex,  $w_i$  say. And since  $g(G) \geq 7$  we have  $N_G(w_i) = \{v_{i-2}, v_{i+2}, x\}$  for some  $x \in \{w'_i, w''_i\}$ . Note particularly that  $v_{i-2}$  and  $v_{i+2}$  have  $w_i$  as a common neighbor. But since this holds for every  $i \in \{0, \dots, 6\}$ , we have  $\{w'_i, w''_i\} = \{w_{i-2}, w_{i+2}\}$  and so  $w_i$  is adjacent to exactly one vertex in  $\{w_{i-2}, w_{i+2}\}$ . [See Figure 15B.] But now, letting  $W = \{w_0, \dots, w_6\}$ , we note that  $G[W]$  is a 1-regular graph of odd order, an impossibility.  $\square$

**Claim 3.15**  $G$  does not exist.

**Proof.** By Claim 3.14 we have  $g(G) \geq 8$ . Let  $k = g(G)$  and let  $C : u_0 u_1 \dots u_{k-1}$  be a cycle of length  $k$  in  $G$ . Again subscripts are taken modulo  $k$  in the following. For  $i \in \{0, \dots, k-1\}$ , let  $v_i$  be the neighbor of  $u_i$  not on  $C$  and let  $N_G(v_i) = \{u_i, v'_i, v''_i\}$ . Since  $k = g(G)$  we note that if  $\{i, j\} \subseteq \{0, \dots, k-1\}$ , then  $v_i \neq v_j$  and  $\{v'_i, v''_i\} \cap \{v'_j, v''_j\} = \emptyset$ . Furthermore, if  $j = i+1$ , then  $\{v'_i, v''_i\} \cap \{v'_j, v''_j\} = \emptyset$ . Let  $U = \{u_i : i \equiv 1 \pmod{3} \text{ and } i \leq k-2\}$ . If  $k \equiv 0 \pmod{3}$ , let  $U' = U$ , if  $k \equiv 1 \pmod{3}$ , let  $U' = U \cup \{v_{k-1}\}$ , and if  $k \equiv 2 \pmod{3}$ , let  $U' = U \cup \{v_{k-2}, v_{k-1}\}$ . Finally, let  $V' = N_G[U']$ , let  $G' = G - V'$  and let  $S'$  be an  $i(G')$ -set. [See Figure 16.]

Suppose that  $G'$  contains an isolated vertex,  $w$  say. Let  $P_{w_1}, P_{w_2}$  and  $P_{w_3}$  be the shortest paths from  $w$  to  $C$  and let  $w_1$  (respectively,  $w_2$  and  $w_3$ ) be the vertex on both  $C$  and  $P_{w_1}$  (respectively,



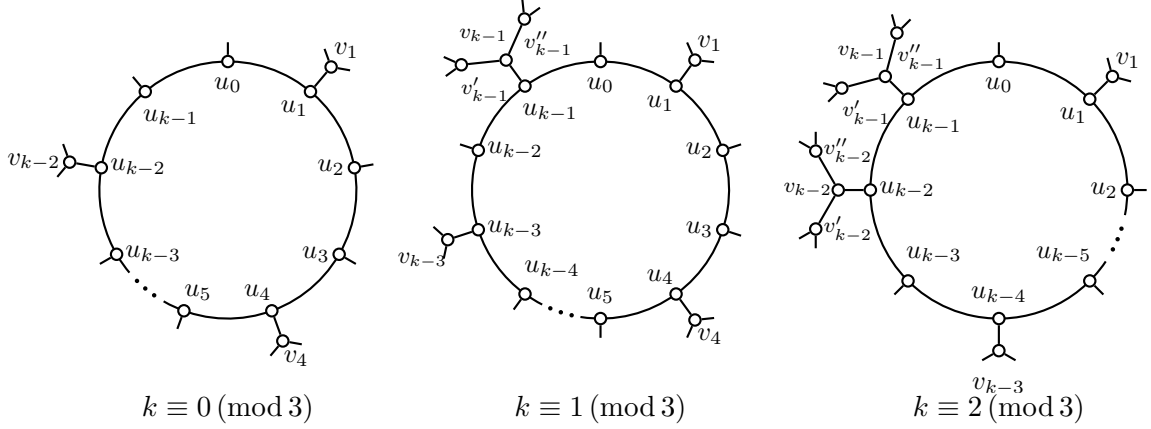

Figure 16: The vertices in  $V'$  and their incident edges.

$P_{w_2}$  and  $P_{w_3}$ ). We note that for  $1 \leq i \leq 3$  the length of  $P_{w_i}$  is at most 3 with equality if and only if  $w_i = u_{k-1}$  when  $k \equiv 1 \pmod{3}$  or  $w_i \in \{u_{k-2}, u_{k-1}\}$  when  $k \equiv 2 \pmod{3}$ . We note further that  $w_i \neq w_j$  for  $1 \leq i < j \leq 3$ , otherwise  $w_i = w_j = u_\ell$  for some  $\ell \in \{k-2, k-1\}$  and  $wv'_\ell v_\ell v''_\ell$  is a 4-cycle in  $G$ , contradicting Claim 3.10. Necessarily, for some  $1 \leq i < j \leq 3$ , the shortest path from  $w_i$  to  $w_j$  along  $C$  has length at most  $\lfloor k/3 \rfloor$ . Consider the cycle,  $C'$ , that traverses this path from  $w_i$  to  $w_j$ , then traverses  $P_{w_j}$  from  $w_j$  to  $w$  and finally returns to  $w_i$  along  $P_{w_i}$ . If  $P_{w_i}$  and  $P_{w_j}$  both have length 3, then  $k \equiv 2 \pmod{3}$  and  $\{w_i, w_j\} = \{u_{k-2}, u_{k-1}\}$ . But then  $C'$  has length 7, contradicting Claim 3.14. Hence, at least one of  $P_{w_i}$  and  $P_{w_j}$  has length at most 2 and so the length of  $C'$  is at most  $\lfloor k/3 \rfloor + 3 + 2$ . But since  $k > 8$  we have  $\lfloor k/3 \rfloor + 5 < k$ , contradicting the fact that  $k = g(G)$ . Therefore,  $G'$  contains no isolated vertices.

We now observe that  $|V'| = 4|U'|$  and therefore  $\omega_G(V') = 3|V'| = 12|U'|$ . We observe further that every vertex in  $U'$  can be uniquely associated with at most four exit edges of  $V'$  in  $G$  and so  $\xi_G(V') \leq 4|U'|$ . Therefore, since  $G'$  contains no isolated vertices, by Fact 1, we have  $\psi_G(V') = \xi_G(V') \leq 4|U'|$ . Thus  $\omega_G(V') - \psi_G(V') \geq 12|U'| - 4|U'| = 8|U'|$ . But  $S' \cup U'$  is an  $ID$ -set of  $G$  and so by Fact 2 we have  $\omega_G(V') - \psi_G(V') < 8|U'|$ , a contradiction.  $\square$

## 4 Consequences of Main Result

As a consequence of our main result, namely Theorem 3, we have the following upper bound on the domination number of a subcubic graph. A proof of Theorem 5 is given in Section 4.1.

**Theorem 5** *If  $G$  is a subcubic graph, then*

$$8\gamma(G) \leq 8n_0(G) + 5n_1(G) + 4n_2(G) + 3n_3(G).$$

As a special case of Theorem 5, we have the following important result due to Reed [9].

**Corollary 6** (Reed [9]) *If  $G$  is a cubic graph of order  $n$ , then  $\gamma(G) \leq 3n/8$ .*

If  $G$  is a subcubic graph of order  $n$  and size  $m$  with  $i$  isolated vertices, then we note that  $8n_0(G) + 5n_1(G) + 4n_2(G) + 3n_3(G) = 6n - 2m + 2i$ . Hence, as an immediate consequence of Theorem 5 we have the following result due to Fischer, Fraughnaugh, and Seager [1] and Rautenbach [8].

**Corollary 7** (Fischer, Fraughnaugh, Seager [1], Rautenbach [8]) *If  $G$  is a subcubic graph of order  $n$ , size  $m$ , with  $i$  isolated vertices, then  $4\gamma(G) \leq 3n - m + i$ .*

#### 4.1 Proof of Theorem 5

Let  $G = (V(G), E(G))$  be a counterexample to Theorem 5 with minimum order. Clearly  $G$  is connected and contains at least four vertices. We define  $\omega_G$ ,  $\omega$ ,  $\psi_G$  and  $\xi_G$  as in the proof of Theorem 3. We note that Fact 1 holds and present the following two additional facts which will be useful in the proof. Fact 3 holds by the minimality of  $G$ .

**Fact 3** *If  $G'$  is a subcubic graph and  $n(G') < n(G)$ , then  $8\gamma(G') \leq \omega(G')$ .*

**Fact 4** *Let  $X$  be a nonempty, proper subset of vertices of  $G$ , let  $G' = G - X$ , and let  $S'$  be a  $\gamma(G')$ -set. If  $S' \cup S$  is a dominating set of  $G$ , then  $\omega_G(X) - \psi_G(X) < 8|S|$ .*

**Proof.** Suppose  $S' \cup S$  is a dominating set of  $G$ . Since  $G$  is a counterexample to Theorem 5 we have  $\omega(G) < 8\gamma(G)$ . By Fact 3, we have  $8\gamma(G') \leq \omega(G')$ . But now, since  $S' \cup S$  is a dominating set of  $G$ , we have that

$$\omega(G) < 8\gamma(G) \leq 8\gamma(G') + 8|S| \leq \omega(G') + 8|S| = \omega(G) - \omega_G(X) + \psi_G(X) + 8|S|,$$

and the desired result follows.  $\square$

We now return to the proof of Theorem 5. If  $G = C_5 \square K_2$ , then  $G$  is cubic and can be dominated by three of its ten vertices. But then  $8\gamma(G) < 10\gamma(G) = 3|V(G)| = 3n_3(G) = \omega(G)$ , contradicting the fact that  $G$  is a counterexample to Theorem 5. Hence,  $G \neq C_5 \square K_2$ . Further, if  $G$  contains no subgraph of  $G$  isomorphic to  $K_{2,3}$ , then by Theorem 3 we get  $8\gamma(G) \leq 8i(G) \leq \omega(G)$ , again contradicting our choice of  $G$ . Consequently,  $G$  has at least one subgraph isomorphic to  $K_{2,3}$ . We choose  $\{a, b\} \subseteq V(G)$  such that  $d_G(a) = d_G(b) = 3$  and  $N_G(a) = N_G(b)$ . Let  $N_G(a) = \{x, y, z\}$ .

We present a series of claims describing some structural properties of  $G$  which culminate in the implication of its non-existence.

**Claim 5.1** *Each vertex in  $\{x, y, z\}$  has degree 3.*

**Proof.** If  $d_G(x) = d_G(y) = d_G(z) = 2$ , then  $G = K_{2,3}$  and  $\gamma(G) = 2$  while  $\omega(G) = 18$ , and so  $8\gamma(G) < \omega(G)$ , contradicting the fact that  $G$  is a counterexample to Theorem 5. Thus, relabelling vertices if necessary, we may assume  $d_G(z) = 3$ . Let  $N_G(z) = \{a, b, z'\}$ .

We consider the case when  $d_G(x) = d_G(y) = 2$ . If  $d_G(z') = 1$ , then the graph  $G$  is determined and  $\gamma(G) = 2$  while  $\omega(G) = 22$ , a contradiction. Hence,  $d_G(z') \geq 2$ . [See Figure 17(A).] Let  $V_1 = \{a, b, x, y, z\}$ , let  $G_1 = G - V_1$  and let  $S_1$  be a  $\gamma(G_1)$ -set. We note that  $\omega_G(V_1) = 3 \cdot 3 + 2 \cdot 4 = 17$ . We note further that  $V_1$  has exactly one exit edge in  $G$  and that  $G_1$  contains no isolated vertex. Therefore, by Fact 1,  $\psi_G(V_1) = \xi_G(V_1) = 1$ . Consequently,  $\omega_G(V_1) - \psi_G(V_1) = 17 - 1 = 16$ . But  $S_1 \cup \{a, b\}$  is a dominating set of  $G$ , and so by Fact 4 we have  $\omega_G(V_1) - \psi_G(V_1) < 8|\{a, b\}| = 16$ , a contradiction. Thus, relabelling vertices if necessary, we may assume  $d_G(y) = 3$ .

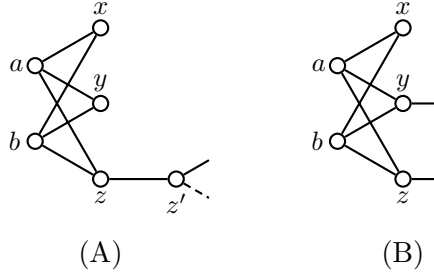

Figure 17: Illustrations for Claim 5.1.

We may now assume that  $d_G(x) = 2$ , for otherwise we are done. [See Figure 17(B).] If  $yz \in E(G)$ , then the graph  $G$  is determined and  $\gamma(G) = 2$  while  $\omega(G) = 16$ , a contradiction. Thus,  $yz \notin E(G)$ . Let  $V_2 = \{a, b, x\}$ , let  $G_2$  be the graph obtained from  $G - V_2$  by adding the edge  $yz$  and let  $S_2$  be a  $\gamma(G_2)$ -set. Summing the weights of vertices carefully, we observe that

$$\omega(G_2) = \omega(G) - (\omega_G(V_2) - \xi_G(V_2) + 2) = \omega(G) - (10 - 4 + 2) = \omega(G) - 8.$$

Now, if  $\{y, z\} \cap S_2 = \emptyset$ , then  $S_2 \cup \{x\}$  is a dominating set of  $G$ . On the other hand, if  $\{y, z\} \cap S_2 \neq \emptyset$ , then we may assume (relabelling vertices if necessary) that  $y \in S_2$ . Then,  $S_2 \cup \{a\}$  is a dominating set of  $G$ . In both case,  $\gamma(G) \leq \gamma(G_2) + 1$ . But now, using Fact 3, we get

$$8\gamma(G) \leq 8\gamma(G_2) + 8 \leq \omega(G_2) + 8 = (\omega(G) - 8) + 8 = \omega(G),$$

contradicting the fact that  $G$  is a counterexample to Theorem 5.  $\square$

**Claim 5.2**  *$\{x, y, z\}$  is an independent set in  $G$ .*

**Proof.** Suppose to the contrary that  $\{x, y, z\}$  is not an independent set in  $G$ . Relabelling vertices if necessary, we may assume  $xy \in E(G)$ . Let  $N_G(z) = \{a, b, z'\}$ . [See Figure 18.] Let

$V' = \{a, b, x, y\}$ , let  $G' = G - V'$  and let  $S'$  be a  $\gamma(G')$ -set. We note that  $\omega_G(V') = 4 \cdot 3 = 12$ . We note further that  $V'$  has two exit edges in  $G$  and that  $G'$  contains no isolated vertex. Therefore, by Fact 1,  $\psi_G(V') = \xi_G(V') = 2$ . Consequently,  $\omega_G(V') - \psi_G(V') = 12 - 2 = 10$ . But  $S' \cup \{x\}$  is a dominating set of  $G$ , and so by Fact 4 we have  $\omega_G(V') - \psi_G(V') < 8$ , a contradiction.  $\square$

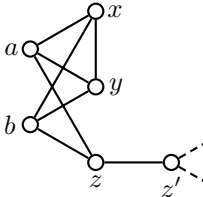

Figure 18: Illustration for Claim 5.2.

**Claim 5.3** *Each vertex in  $N_G(\{x, y, z\})$  has degree at least 2.*

**Proof.** Suppose to the contrary that for some  $z' \in N_G(\{x, y, z\})$  we have  $d_G(z') = 1$ . Relabelling vertices if necessary, we may assume  $z' \in N_G(z)$ . [See Figure 19.] Let  $V' = \{a, b, z, z'\}$ , let  $G' = G - V'$  and let  $S'$  be a  $\gamma(G')$ -set. We note that  $\omega_G(V') = 3 \cdot 3 + 1 \cdot 5 = 14$ , that  $V'$  has four exit edges in  $G$ , and that  $G'$  contains no isolated vertex. Therefore, by Fact 1,  $\psi_G(V') = \xi_G(V') = 4$ . Consequently,  $\omega_G(V') - \psi_G(V') \geq 14 - 4 = 10$ . But  $S' \cup \{z\}$  is a dominating set of  $G$ , and so by Fact 4 we have  $\omega_G(V') - \psi_G(V') < 8$ , a contradiction.  $\square$

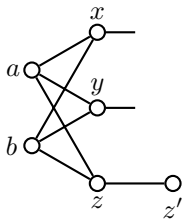

Figure 19: Illustration for Claim 5.3.

**Claim 5.4** *Each vertex in  $N_G(\{x, y, z\})$  has degree 3.*

**Proof.** Suppose to the contrary that for some  $z' \in N_G(\{x, y, z\})$  we have  $d_G(z') < 3$ . By Claim 5.3 we have  $d_G(z') = 2$ . By Claim 5.2, we note that  $z' \notin \{x, y, z\}$ . Relabelling vertices if necessary, we may assume  $z' \in N_G(z)$ .

We suppose first that  $z' \in N_G(\{x, y\})$ . Relabelling vertices if necessary, we may assume that  $z' \in N_G(y)$ . Let  $N_G(x) = \{a, b, x'\}$ . By Claim 5.3, we have  $d_G(x') \geq 2$ . [See Figure 20(A).] Let  $V_1 = \{a, b, x, y, z, z'\}$ , let  $G_1 = G - V_1$  and let  $S_1$  be a  $\gamma(G_1)$ -set. We note that  $\omega_G(V_1) = 5 \cdot 3 + 1 \cdot 4 = 19$ . We note further that  $V_1$  has exactly one exit edge in  $G$  and that  $G_1$  contains no isolated vertex. Therefore, by Fact 1,  $\psi_G(V_1) = \xi_G(V_1) = 1$ . Consequently,  $\omega_G(V_1) - \psi_G(V_1) = 19 - 1 = 18$ .

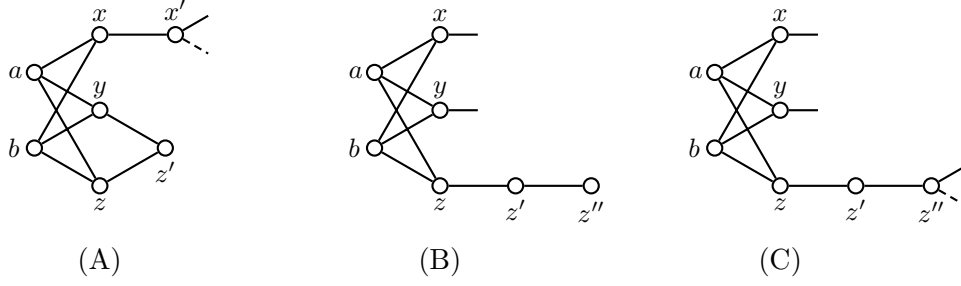

Figure 20: Illustrations for Claim 5.4.

But  $S_1 \cup \{a, y\}$  is a dominating set of  $G$ , and so by Fact 4 we have  $\omega_G(V_1) - \psi_G(V_1) < 16$ , a contradiction. Hence,  $z' \notin N_G(\{x, y\})$ .

Let  $N_G(z') = \{z, z''\}$ . Suppose  $d_G(z'') = 1$ . [See Figure 20(B).] Let  $V_2 = \{z', z''\}$ , let  $G_2 = G - V_2$  and let  $S_2$  be a  $\gamma(G_2)$ -set. We note that  $\omega_G(V_2) = 1 \cdot 4 + 1 \cdot 5 = 9$ , that  $V_2$  has exactly one exit edge in  $G$ , and that  $G_2$  contains no isolated vertex. Therefore, by Fact 1,  $\psi_G(V_2) = \xi_G(V_2) = 1$ . Consequently,  $\omega_G(V_2) - \psi_G(V_2) = 9 - 1 = 8$ . But  $S_2 \cup \{z'\}$  is a dominating set of  $G$ , and so by Fact 4 we have  $\omega_G(V_2) - \psi_G(V_2) < 8$ , a contradiction. Hence,  $d_G(z'') \geq 2$ . [See Figure 20(C).] We now let  $V_3 = \{a, b, z, z'\}$ , let  $G_3 = G - V_3$  and let  $S_3$  be a  $\gamma(G_3)$ -set. We note now that  $\omega_G(V_3) = 3 \cdot 3 + 1 \cdot 4 = 13$ , that  $V_3$  has five exit edges in  $G$ , and that  $G_3$  contains no isolated vertex. Therefore, by Fact 1,  $\psi_G(V_3) = \xi_G(V_3) = 5$ . Consequently,  $\omega_G(V_3) - \psi_G(V_3) = 13 - 5 = 8$ . But  $S_3 \cup \{z\}$  is a dominating set of  $G$ , and so by Fact 4 we have  $\omega_G(V_3) - \psi_G(V_3) < 8$ , another contradiction.  $\square$

**Claim 5.5** *If  $v \in N_G(\{x, y, z\}) \setminus \{a, b\}$ , then  $|N_G(v) \cap \{x, y, z\}| = 1$ .*

**Proof.** Every vertex in  $N_G(\{x, y, z\}) \setminus \{a, b\}$  has at least one neighbor in  $\{x, y, z\}$ . Suppose to the contrary that some vertex  $v \in N_G(\{x, y, z\}) \setminus \{a, b\}$  has at least two neighbors in  $\{x, y, z\}$ . If  $N_G(v) = \{x, y, z\}$ , then  $G = K_{3,3}$  and  $\gamma(G) = 2$  while  $\omega(G) = 18$ , and so  $8\gamma(G) < \omega(G)$ , a contradiction. Hence, the vertex  $v$  has exactly two neighbors in  $\{x, y, z\}$ . Relabelling vertices if necessary, we may assume  $\{y, z\} \subseteq N_G(v)$  for some vertex  $v \in N_G(\{x, y, z\}) \setminus \{a, b\}$ . Let  $N_G(v) = \{y, z, v'\}$ . We note that  $v' \neq x$ .

Suppose  $d_G(v') = 1$ . [See Figure 21(A).] Let  $V_1 = \{y, z, v, v'\}$ , let  $G_1 = G - V_1$  and let  $S_1$  be a  $\gamma(G_1)$ -set. We note that  $\omega_G(V_1) = 3 \cdot 3 + 1 \cdot 5 = 14$ . We note further that  $V_1$  has four exit edges in  $G$  and that  $G_1$  contains no isolated vertex. Therefore, by Fact 1,  $\psi_G(V_1) = \xi_G(V_1) = 4$ . Consequently,  $\omega_G(V_1) - \psi_G(V_1) = 14 - 4 = 10$ . But  $S_1 \cup \{v\}$  is a dominating set of  $G$ , and so by Fact 4 we have  $\omega_G(V_1) - \psi_G(V_1) < 8$ , a contradiction. Hence,  $d_G(v') \geq 2$ .

Let  $N_G(x) = \{a, b, x'\}$  (possibly,  $x' = v'$ ). By Claim 5.4 we have  $d_G(x') = 3$ . [See Figure 21(B) and (C).] Let  $V_2 = \{a, b, x, y, z, v\}$ , let  $G_2 = G - V_2$  and let  $S_2$  be a  $\gamma(G_2)$ -set. We note that  $\omega_G(V_2) = 6 \cdot 3 = 18$ , that  $V_2$  has two exit edges in  $G$ , and that  $G_2$  contains no isolated vertex. Therefore, by Fact 1,  $\psi_G(V_2) = \xi_G(V_2) = 2$ . Consequently,  $\omega_G(V_2) - \psi_G(V_2) = 18 - 2 = 16$ .

But  $S_2 \cup \{a, y\}$  is a dominating set of  $G$ , and so by Fact 4 we have  $\omega_G(V_2) - \psi_G(V_2) < 16$ , a contradiction.  $\square$

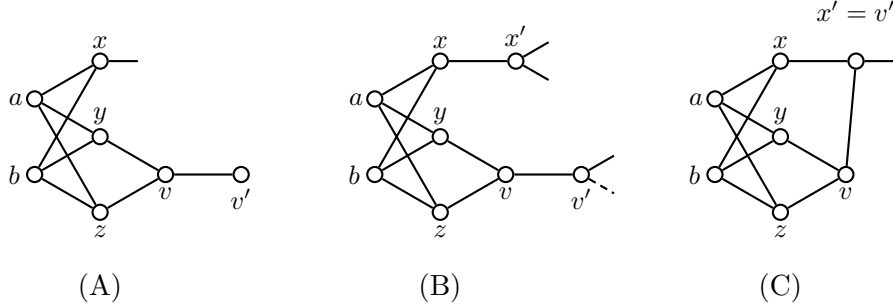

Figure 21: Illustrations for Claim 5.5.

Before presenting our final two claims, we let  $N_G(x) = \{a, b, x'\}$ ,  $N_G(y) = \{a, b, y'\}$  and  $N_G(z) = \{a, b, z'\}$ . By Claim 5.5, the three vertices  $x', y', z'$  are all distinct. If  $\{x'y', x'z', y'z'\} \subseteq E(G)$ , then the graph  $G$  is determined and  $\gamma(G) = 3$  while  $\omega(G) = 24$ , and so  $8\gamma(G) = \omega(G)$ , a contradiction. Hence, relabelling vertices if necessary, we may assume  $x'y' \notin E(G)$ . We now present our final two claims.

**Claim 5.6** *Each vertex in  $N_G(z')$  has degree at least 2.*

**Proof.** Let  $N_G(z') = \{z, z_1, z_2\}$  (possibly  $\{x', y'\} \cap \{z_1, z_2\} \neq \emptyset$ ). Suppose first that  $d_G(z_1) = d_G(z_2) = 1$ . [See Figure 22(A).] Let  $V_1 = \{z', z_1, z_2\}$ , let  $G_1 = G - V_1$  and let  $S_1$  be a  $\gamma(G_1)$ -set. We note that  $\omega_G(V_1) = 1 \cdot 3 + 2 \cdot 5 = 13$ , that  $V_1$  has one exit edge in  $G$ , and that  $G_1$  contains no isolated vertex. Therefore, by Fact 1,  $\psi_G(V_1) = \xi_G(V_1) = 1$ . Consequently,  $\omega_G(V_1) - \psi_G(V_1) = 13 - 1 = 12$ . But  $S_1 \cup \{z'\}$  is a dominating set of  $G$ , and so by Fact 4 we have  $\omega_G(V_1) - \psi_G(V_1) < 8$ , a contradiction. Hence, relabelling vertices if necessary, we may assume  $d_G(z_1) \geq 1$ .

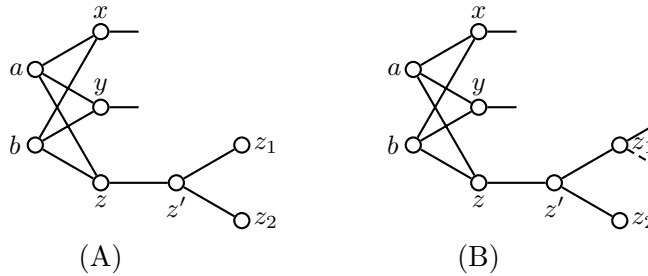

Figure 22: Illustrations for Claim 5.6.

Suppose that  $d_G(z_2) = 1$ . [See Figure 22(B).] Let  $V_2 = \{z, z', z_2\}$ , let  $G_2 = G - V_2$  and let  $S_2$  be a  $\gamma(G_2)$ -set. We note that  $\omega_G(V_2) = 2 \cdot 3 + 1 \cdot 5 = 11$ , that  $V_2$  has three exit edges in  $G$ , and

that  $G_2$  contains no isolated vertex. Therefore, by Fact 1,  $\psi_G(V_2) = \xi_G(V_2) = 3$ . Consequently,  $\omega_G(V_2) - \psi_G(V_2) = 11 - 3 = 8$ . But  $S_2 \cup \{z'\}$  is a dominating set of  $G$ , and so by Fact 4 we have  $\omega_G(V_2) - \psi_G(V_2) < 8$ , a contradiction. The desired result follows.  $\square$

**Claim 5.7**  $G$  does not exist.

**Proof.** [See Figure 23.] Recall that  $x'y' \notin E(G)$  but possibly  $x'z' \in E(G)$  or  $y'z' \in E(G)$ . Let  $V' = \{a, b, x, y, z, z'\}$ , let  $G'$  be the graph obtained from  $G - V'$  by adding the edge  $x'y'$  and let  $S'$  be a  $\gamma(G')$ -set. By Claim 5.6, we have that  $G'$  contains no isolated vertex. Summing the weights of vertices carefully, we observe that

$$\omega(G') = \omega(G) - (\omega_G(V') - \xi_G(V') + 2) = \omega(G) - (3 \cdot 6 - 4 + 2) = \omega(G) - 16.$$

On the one hand, if  $\{x', y'\} \cap S' = \emptyset$ , then  $S' \cup \{a, z\}$  is a dominating set of  $G$ . On the other hand, if  $\{x', y'\} \cap S' \neq \emptyset$ , then we may assume (relabeling vertices if necessary) that  $x' \in S'$ . In this case,  $S' \cup \{y, z\}$  is a dominating set of  $G$ . In both cases,  $\gamma(G) \leq \gamma(G') + 2$ . But now, using Fact 3, we get

$$8\gamma(G) \leq 8\gamma(G') + 16 \leq \omega(G') + 16 = \omega(G),$$

contradicting the fact that  $G$  is counterexample to Theorem 5.  $\square$

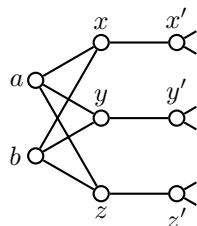

Figure 23: Illustration for Claim 5.7.

## 4.2 Closing Remarks

It is conjectured in [2] that if  $G \notin \{K_{3,3}, C_5 \square K_2\}$  is a connected cubic graph on  $n$  vertices, then  $i(G) \leq 3n/8$ . In this paper we give support to this conjecture by proving that the conjecture holds if the cubic graph  $G$  contains no subgraph isomorphic to  $K_{2,3}$ . As a consequence of this result, we deduce the main part of Reed's [9] important result that if  $G$  is an  $n$  vertices graph with minimum degree 3, then  $\gamma(G) \leq 3n/8$ . We remark that Reed's proof, which uses ingenious counting arguments, is very technical in parts and some cases in the proof are best checked using a computer proof. If  $\mathcal{G}_{\text{cubic}}^n$  denotes the family of all connected cubic graphs of order  $n$ , then the following is known ([6, 7]).

$$0.35 = \frac{1}{3} + \frac{1}{60} \leq \sup_{G \in \mathcal{G}_{\text{cubic}}^n} \left( \lim_{n \rightarrow \infty} \frac{\gamma(G)}{n(G)} \right) \leq \frac{1}{3} + \frac{1}{42} \approx 0.35714.$$

It remains, however, one of the outstanding open problems in domination theory to determine what this supremum is. We remark that the very detailed 40-page proof due to Kostochka and Stocker [7] to establish the current best upper bound for the supremum, adopts Reed's proof technique. We close with the following question. Using the proof techniques in the current paper, can the best known upper bound for the supremum be improved?

## References

- [1] D. C. Fischer, K. Fraughnaugh, and S. M. Seager, Domination in graphs with maximum degree three. *Proceedings of the Eight Quadrennial International Conference of Graph Theory, Combinatorics, Algorithms, and Applications*. Ed. Y. Alavi, D. R. Lick, and A. Schwenk (1999), 411–421.
- [2] W. Goddard and M. A. Henning, Independent domination in graphs: A survey and recent results. *Discrete Math.* **313** (2013), 839–854.
- [3] W. Goddard, M. A. Henning, J. Lyle, and J. Southey, On the independent domination number of regular graphs. *Annals Combin.* **16** (2012), 719–732.
- [4] T. W. Haynes, S. T. Hedetniemi, and P. J. Slater, *Fundamentals of Domination in Graphs*, Marcel Dekker, Inc. New York, 1998.
- [5] T. W. Haynes, S. T. Hedetniemi, and P. J. Slater, *Domination in Graphs: Advanced Topics*, Marcel Dekker, Inc. New York, 1998.
- [6] A. Kelmans, Counterexamples to the cubic graph domination conjecture, arXiv:math.CO/0607512 v1 20 July 2006.
- [7] A. V. Kostochka and C. Stocker, A new bound on the domination number of connected cubic graphs. *Sib. Elektron. Mat. Izv.* **6** (2009), 465–504.
- [8] D. Rautenbach, A linear Vizing-like relation between the size and the domination number of a graph. *J. Graph Theory* **31** (1999), 297–302.
- [9] B. A. Reed, Paths, stars and the number three. *Combin. Probab. Comput.* **5** (1996), 277–295.
- [10] P. C. B. Lam, W. C. Shiu, and L. Sun, On independent domination number of regular graphs. *Discrete Math.* **202** (1999), 135–144.