

Vector valued Jack polynomials

Jean-Gabriel Luque

Vector valued Jack polynomials from scratch

C.F. Dunkl* and J.-G. Luque†

What are Jack polynomials?

The story begins in 1960's...

Inner product:

$$\langle f, g \rangle_w = \int_I f(x)g(x)w(x)dx$$

Orthogonal polynomials $\langle p_i, p_j \rangle_w = 0$ if $i \neq j$

How to define multivariate orthogonal polynomials?

$$\int_{I^n} p_\kappa^\alpha(x_1, \dots, x_n) p_\mu^\alpha(x_1, \dots, x_n) \prod_{i < j} |x_i - x_j|^\beta \prod_{j=1}^n w(x_j) dx_1 \dots dx_n = \delta_{\kappa\mu}$$

Interpretation of the power of the Vandermonde: Symmetric repulsion factor which depends on a "Boltzmann" constant $\beta=2/\alpha$.

First question: what replace the monomial x^k ?

Answer : The Jack polynomials

What are Jack polynomials?

James discovered the zonal polynomials :

Alan T. James. The distribution of the latent roots of the covariance matrix. *Ann. Math. Stat.*, 31:151–158, 1960.

Also Hua :

L.K. Hua. Harmonic Analysis of functions of several complex variables in the classical domains. *Transl. Math. Monogr. Am. Math. Soc.*, 6, 1963.

(symmetric) Jack polynomials:

Henry Jack. A class of symmetric polynomials with a parameter. *Proc. R. Soc. Edinburgh*, 69:1–18, 1970.

One parameters class of polynomials :

$\alpha=1$ Schur, $\alpha=2$ zonal, $\alpha=1/2$ quaternionic zonal

What are Jack polynomials?

More ? See

MOPS: Multivariate Orthogonal Polynomials (symbolically)

Ioana Dumitriu, Alan Edelman, and Gene Shuman

What are Jack polynomials?

Several generalizations:

- 1- Two parameters (q,t) - Macdonald polynomials
- 2- Jack and Macdonald polynomials of others root systems (classical = A_n)
- 3- Non-Symmetric and non-homogeneous (shifted) Jack polynomials

What are Jack polynomials?

Several connections:

1- Multivariate orthogonal polynomials (Jacobi, Laguerre, Hermite).
See Forrester, Lassalle...

2- Random matrix theory

3- (degenerated) double affine Hecke Algebra

What are Jack polynomials?

A definition of the non-symmetric Jack polynomials:

Simultaneous eigenfunctions of Cherednik elements:

$$\xi_i := \alpha x_i \frac{\partial}{\partial x_i} + \sum_{j \neq i} x_i (1 - s_{ij}) \frac{1}{x_i - x_j} + i - 1$$

These elements generate a commutative algebras and verify

$$\xi_{i+1} s_i = s_i \xi_i - 1 \quad \& \quad (\xi_i + \xi_{i+1}) s_i = s_i (\xi_i + \xi_{i+1}), \quad 1 \leq i \leq n - 1$$

$$\xi_j s_i = s_i \xi_j, \quad j \neq i, i + 1$$

$$\xi_i \Phi = \Phi \xi_{i-1}, \quad i = 1, \dots, n, \quad \xi_0 = \xi_n - \alpha.$$

Motivations

Generalization of Jack polynomials: coefficients in an irreducible module of the symmetric group. "Classical" Jack = trivial representation.

Describe in term of Yang-Baxter graph the special case of the symmetric group of a general construction due to Griffeth for complex reflection groups $G(r,p,N)$.

[8] S. Griffeth, *Orthogonal functions generalizing Jack polynomials*, Trans. Amer. Math. Soc. 362 (2010), 6131-6157.

This special case was studied by C. Dunkl.

[4] C. Dunkl, *Symmetric and antisymmetric Vector valued Jack polynomials*, Sémin. Lothar. Combin. B64a (2010), 31 pp..

Adapt the construction of Lascoux (computation of the Jack polynomials using the Yang-Baxter Graph) to this more general case.

Vector valued polynomials 1

Young seminormal representation of the symmetric group

V_λ spanned by reverse tableaux of shape λ

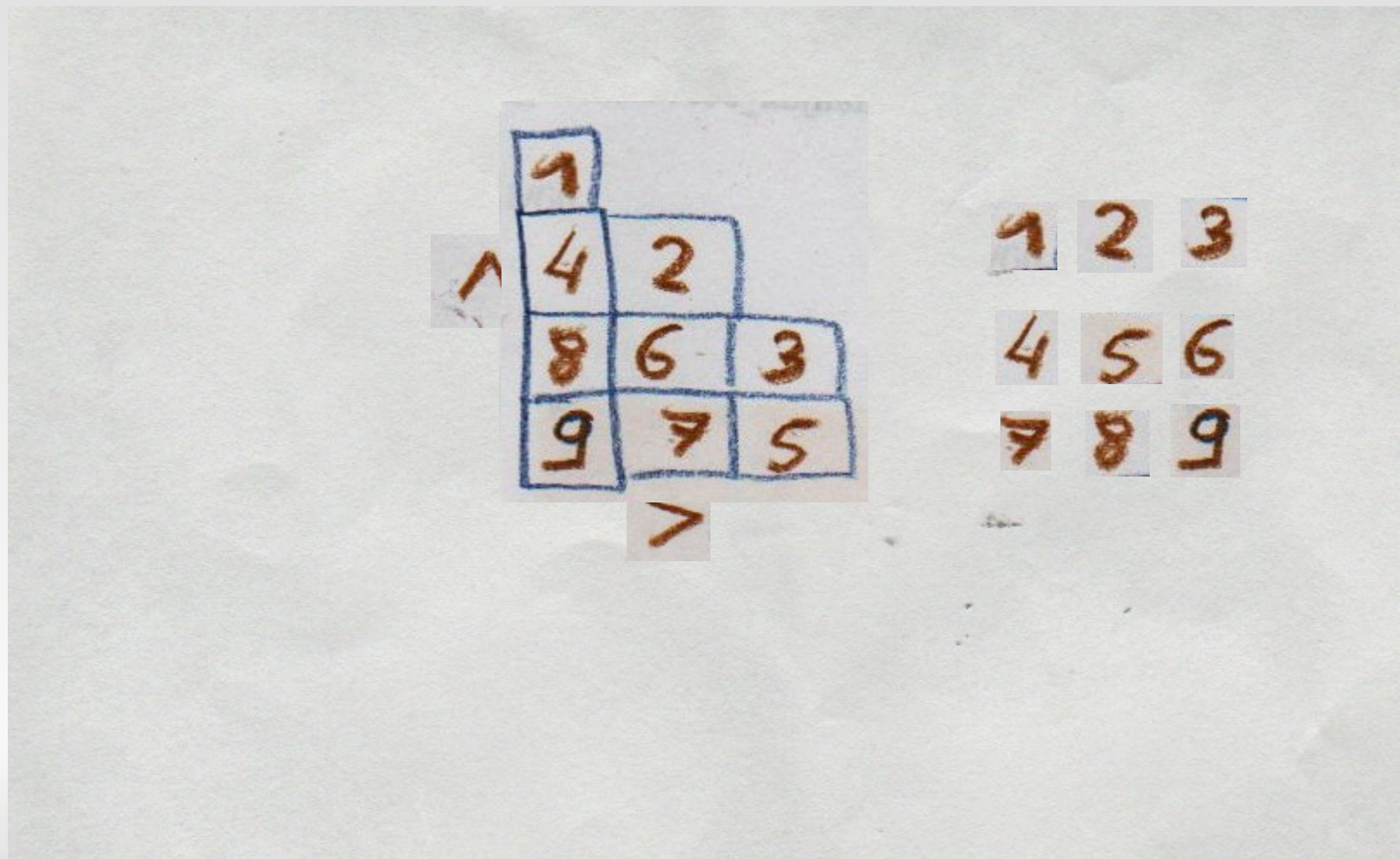

Vector valued polynomials 1

Young seminormal representation of the symmetric group

Tableaux to contents

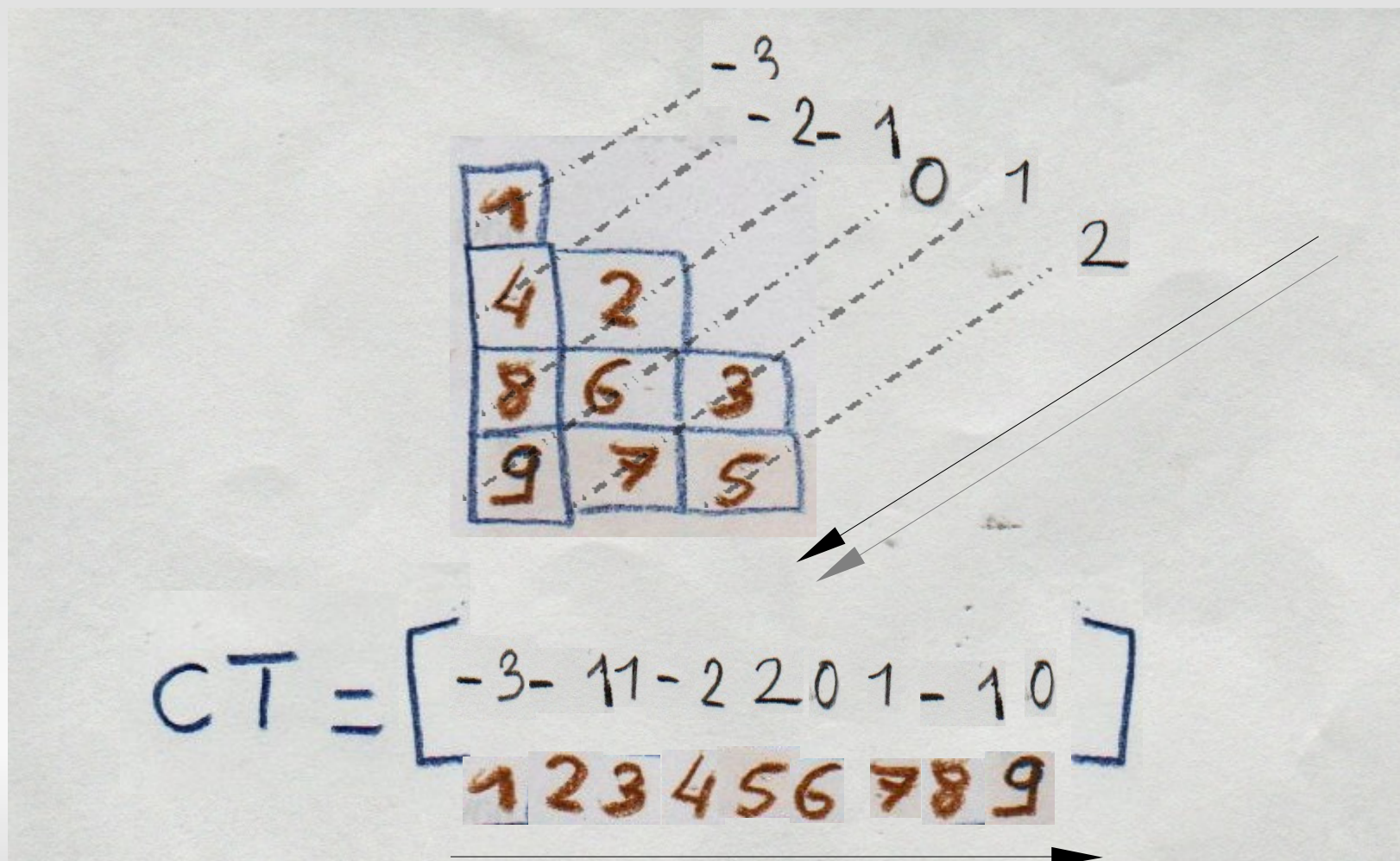

Vector valued polynomials 1

Young seminormal representation of the symmetric group

The tableaux are simultaneous eigenvalues of Jucys-Murphy elements

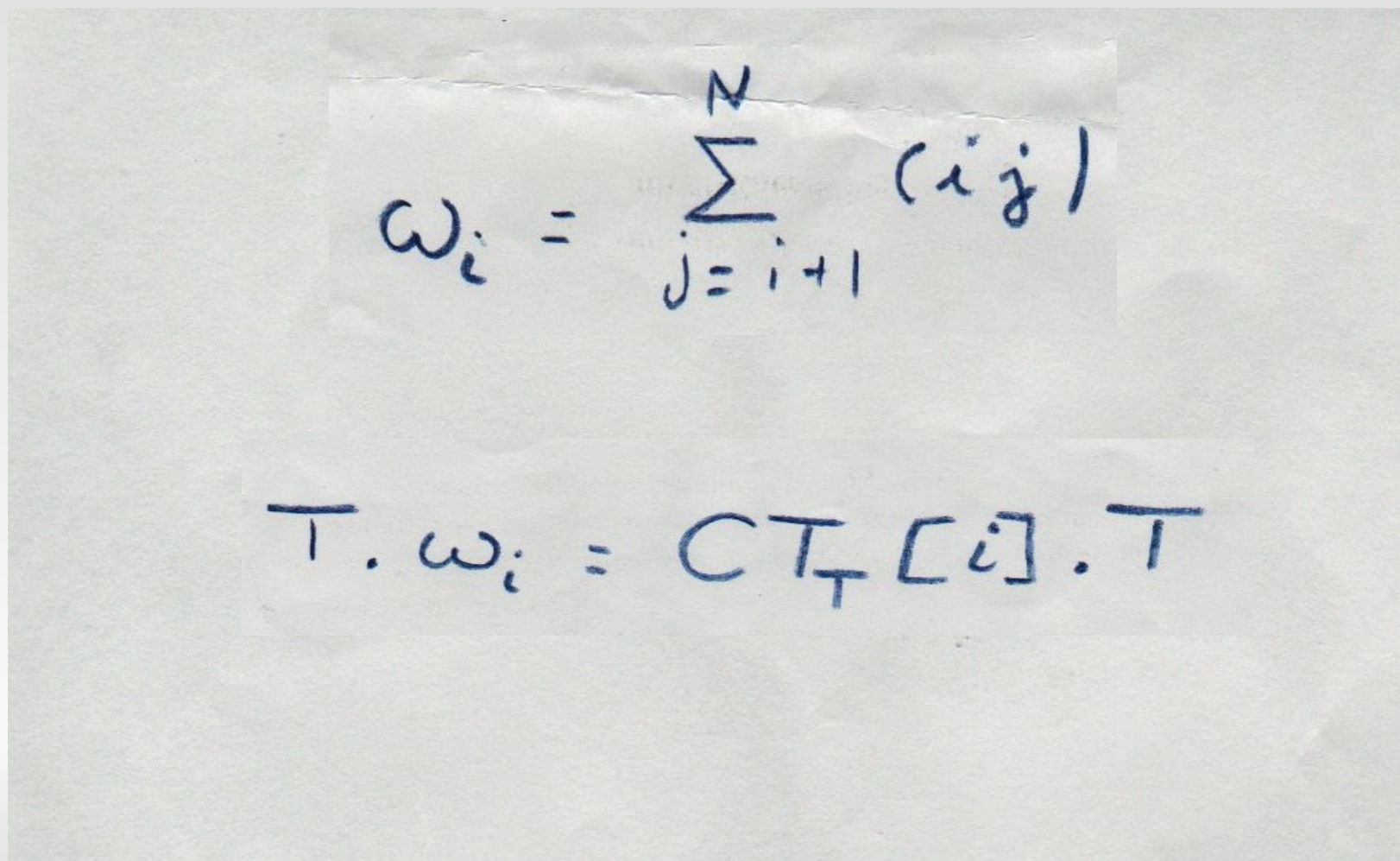

The image shows two pieces of white paper with handwritten mathematical formulas in blue ink. The top piece of paper contains the formula $\omega_i = \sum_{j=i+1}^N (ij)$. The bottom piece of paper contains the formula $T \cdot \omega_i = C_{T_T} [i] \cdot T$.

$$\omega_i = \sum_{j=i+1}^N (ij)$$
$$T \cdot \omega_i = C_{T_T} [i] \cdot T$$

Vector valued polynomials 1

Young seminormal representation of the symmetric group

Construction due to Murphy

Handwritten mathematical notes on a piece of paper. At the top, the formula for $b_T[i]$ is written as:

$$b_T[i] = \frac{1}{CT_T[i] - CT_T[i+1]}$$

Below this, a Young diagram is drawn with four rows and three columns. The numbers 1 through 9 are written in the cells, representing a permutation. The first row has 1, the second row has 4 and 2, the third row has 8, 5, and 3, and the fourth row has 9, 7, and 6.

To the right of the Young diagram, the permutation CT is written as a list of numbers in square brackets:

$$CT = [-3, -1, 1, -2, 0, 2, 1, -1, 0]$$

Below the permutation, the vector b is written as a list of numbers in square brackets:

$$b = \left[-\frac{1}{2}, \frac{1}{2}, \frac{1}{3}, -\frac{1}{2}, -\frac{1}{2}, 1, \frac{1}{2}, -i\right]$$

Vector valued polynomials 1

Young seminormal representation of the symmetric group

Construction due to Murphy

The image shows handwritten mathematical notes on a piece of paper. At the top left, a Young diagram is drawn with two boxes in a row, containing the expressions $i+1$ and i . To the right of this diagram, the value $b = 1$ is written. Below the Young diagram, a larger Young diagram is drawn with four rows: the first row has one box with '1', the second row has two boxes with '4' and '2', the third row has three boxes with '8', '5', and '3', and the fourth row has three boxes with '9', '7', and '6'. A pink circle is drawn around the boxes containing '7' and '6'. To the right of this diagram, the character value $\chi_T = [-3, -1, 1, -2, 0, 2, 1, -1, 0]$ is written. Below that, the vector $b = [-\frac{1}{2}, -\frac{1}{2}, \frac{1}{3}, -\frac{1}{2}, -\frac{1}{2}, 1, \frac{1}{2}, -i]$ is written, with a purple circle around the '1' in the sixth position.

Vector valued polynomials 1

Young seminormal representation of the symmetric group

Construction due to Murphy

The image shows handwritten notes on a piece of paper. At the top left, there is a diagram of a Young diagram with two boxes. The left box contains the expression $i+1$ and the right box contains i . To the right of this diagram, the inequality $0 < b < 1$ is written. Below these, there is a 3x3 grid of numbers:

1		
4	2	
8	5	3
9	7	6

Next to the grid, the vector $c = [-3, -1, 1, -2, 0, 2, 1, -1, 0]$ is written. Below that, the vector $b = [-\frac{1}{2}, -\frac{1}{2}, \frac{1}{3}, -\frac{1}{2}, -\frac{1}{2}, 1, \frac{1}{2}, -i]$ is written. The number $\frac{1}{3}$ in the vector b is circled in pink. A large pink scribble is also present over the grid and the vector c .

Vector valued polynomials 1

Young seminormal representation of the symmetric group

Construction due to Murphy

The image shows handwritten mathematical notes on a piece of paper. At the top left, there is a diagram consisting of two boxes, one labeled i and one labeled $i+1$, enclosed in a larger, irregular blue outline. To the right of this is the inequality $-1 < b < 0$. Below these is a Young diagram with four rows: the first row has one box with the number 1; the second row has two boxes with numbers 4 and 2; the third row has three boxes with numbers 8, 5, and 3; the fourth row has three boxes with numbers 9, 7, and 6. A pink heart is drawn around the box containing the number 5. To the right of the Young diagram is the vector $cT = [-3, -1, 1, -2, 0, 2, 1, -1, 0]$. Below this is another vector $b = [-\frac{1}{2}, -\frac{1}{2}, \frac{1}{3}, -\frac{1}{2}, -\frac{1}{2}, 1, \frac{1}{2}, -i]$, where the $-\frac{1}{2}$ in the fifth position is circled in pink.

Vector valued polynomials 1

Young seminormal representation of the symmetric group

Construction due to Murphy

The image shows handwritten mathematical notes on a piece of paper. At the top left, there is a Young diagram consisting of two boxes stacked vertically, with the top box containing the letter i and the bottom box containing $i+1$. To the right of this diagram, the equation $b = -1$ is written. Below these, there is a larger Young diagram with four rows and three columns. The boxes contain the numbers 1 through 9, arranged in a staircase pattern: the first row has 1, the second row has 4 and 2, the third row has 8, 5, and 3, and the fourth row has 9, 7, and 6. The number 4 in the second row and the number 9 in the fourth row are circled in pink. To the right of this diagram, the character table $CT = [-3, -1, 1, -2, 0, 2, 1, -1, 0]$ is written. Below the character table, the vector $b = [-\frac{1}{2}, -\frac{1}{2}, \frac{1}{3}, -\frac{1}{2}, -\frac{1}{2}, 1, \frac{1}{2}, -1]$ is written, with the last element -1 circled in pink.

Vector valued polynomials 1

Young seminormal representation of the symmetric group

Construction due to Murphy

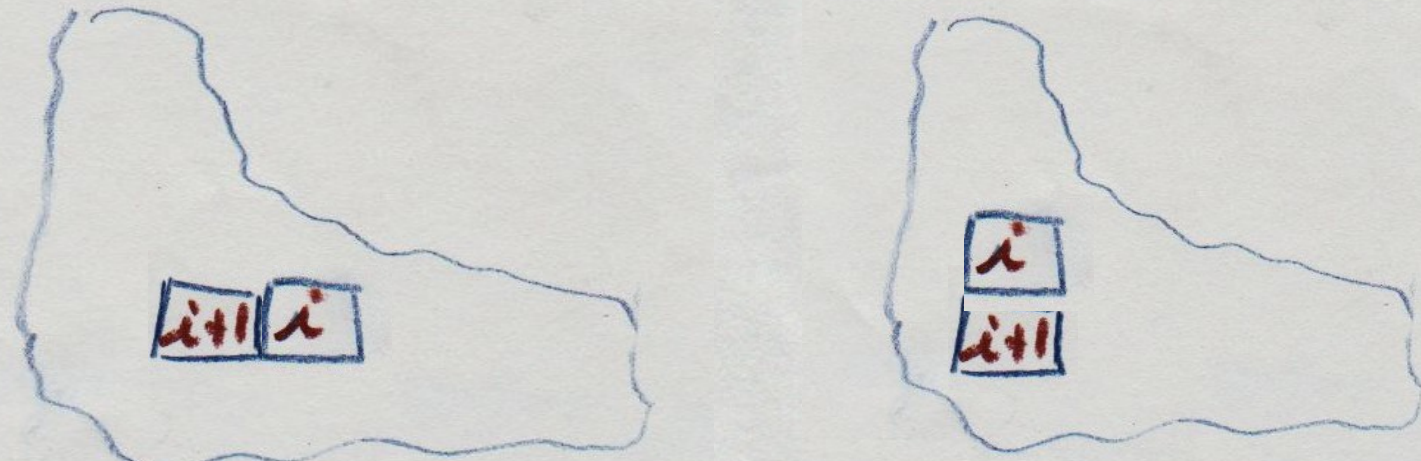
$$\tau \cdot s_i = \begin{cases} b_\tau[i] \tau & \text{if } b_\tau[i]^2 = 1, \\ b_\tau[i] \tau + \tau^{(i,i+1)} & \text{if } 0 < b_\tau[i] \leq \frac{1}{2}, \\ b_\tau[i] \tau + (1 - b_\tau[i]^2) \tau^{(i,i+1)} & \text{otherwise,} \end{cases}$$

Vector valued polynomials 1

Young seminormal representation of the symmetric group

Construction due to Murphy

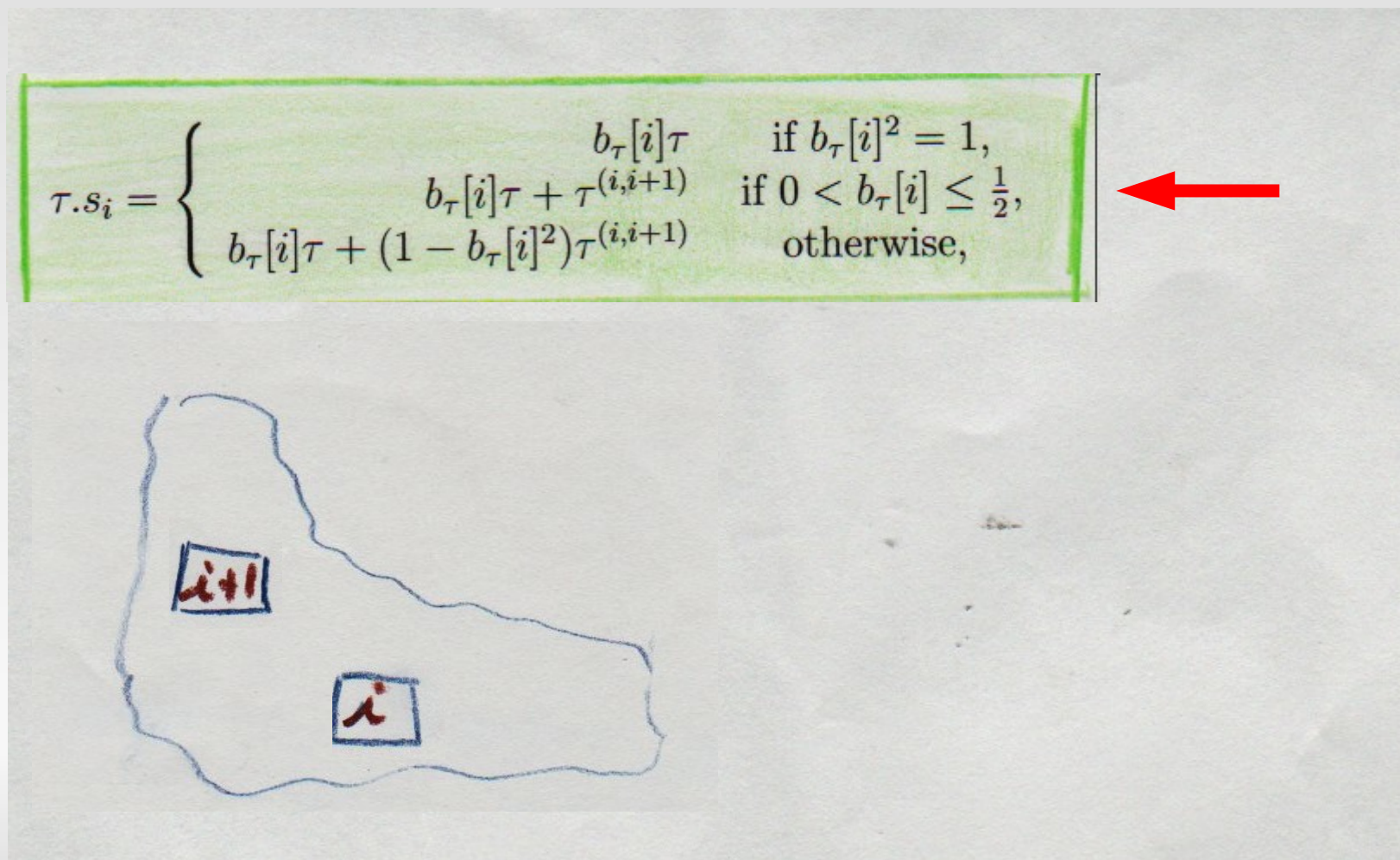

Vector valued polynomials 1

Young seminormal representation of the symmetric group

Construction due to Murphy

$$\tau \cdot s_i = \begin{cases} b_\tau[i] \tau & \text{if } b_\tau[i]^2 = 1, \\ b_\tau[i] \tau + \tau^{(i,i+1)} & \text{if } 0 < b_\tau[i] \leq \frac{1}{2}, \\ b_\tau[i] \tau + (1 - b_\tau[i]^2) \tau^{(i,i+1)} & \text{otherwise,} \end{cases}$$



Vector valued polynomials 1

Young seminormal representation of the symmetric group

Construction due to Murphy

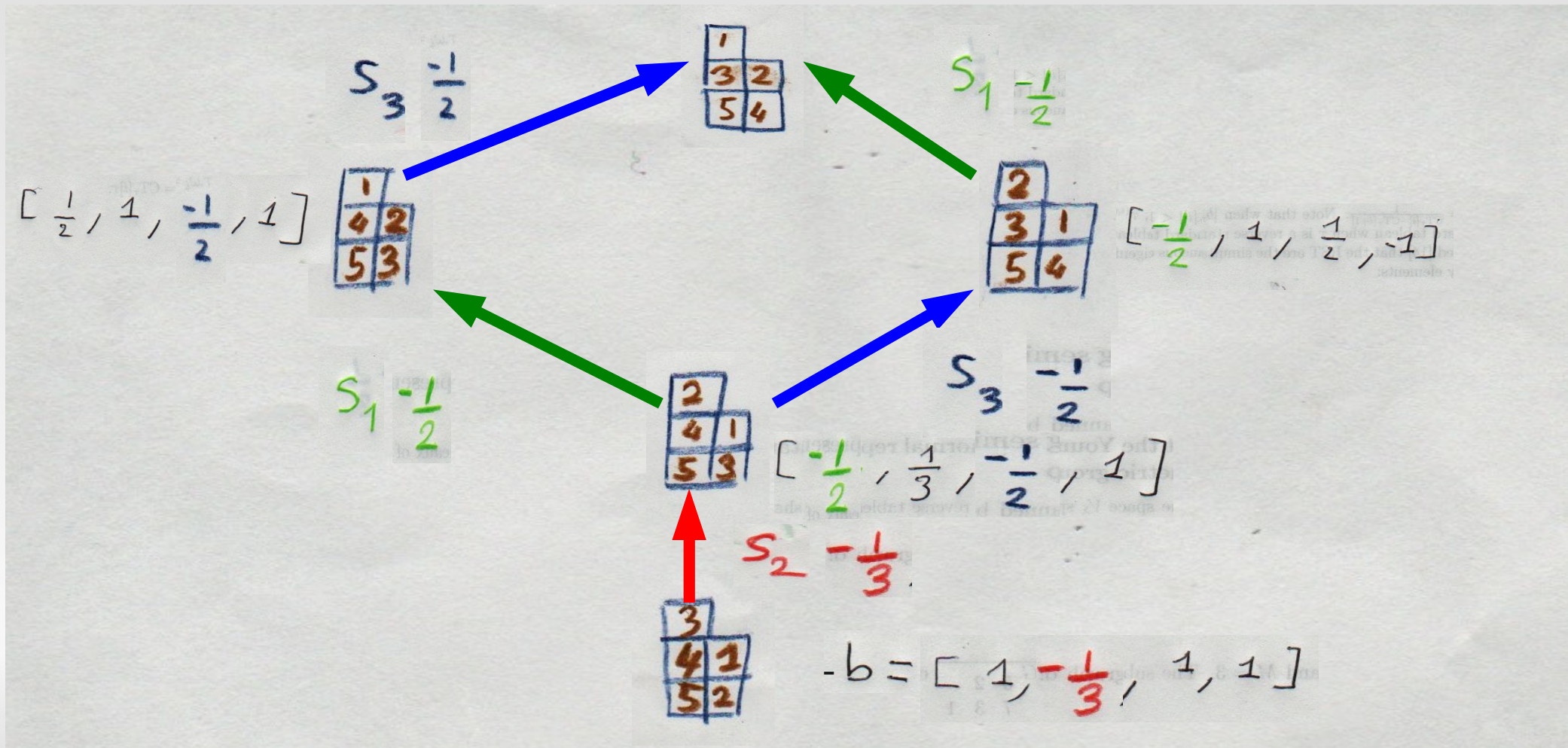

Vector valued polynomials 2

The space of vector valued polynomials

Definition

$$\lambda \vdash N \quad x_1, \dots, x_N$$

$$M_\lambda = \mathbb{C}[x_1, \dots, x_N] \otimes V_\lambda$$

Action of $G_N \otimes G_N$

act by
permutation
of the variables

Murphy

Vector valued polynomials 2

The space of vector valued polynomials

Definition

$$\lambda \vdash N \quad x_1, \dots, x_N$$

$$M_\lambda = \mathbb{C}[x_1, \dots, x_N] \otimes V_\lambda$$

$$\begin{aligned} x_1^3 x_2' \otimes \begin{array}{|c|c|} \hline 2 & \\ \hline 3 & 1 \\ \hline \end{array} \cdot (23) \otimes (12) &= x_1^3 x_2' \otimes \begin{array}{|c|c|} \hline 2 & \\ \hline 3 & 1 \\ \hline \end{array} (23) \otimes (12) \\ &= x_1^3 x_3' \otimes \frac{1}{2} \begin{array}{|c|c|} \hline 2 & \\ \hline 3 & 1 \\ \hline \end{array} + \begin{array}{|c|c|} \hline 1 & \\ \hline 3 & 2 \\ \hline \end{array} \\ &= \frac{1}{2} x_1^3 x_3' \otimes \begin{array}{|c|c|} \hline 2 & \\ \hline 3 & 1 \\ \hline \end{array} + x_1^3 x_3' \otimes \begin{array}{|c|c|} \hline 1 & \\ \hline 3 & 2 \\ \hline \end{array} \end{aligned}$$

Vector valued polynomials 3

Dominance

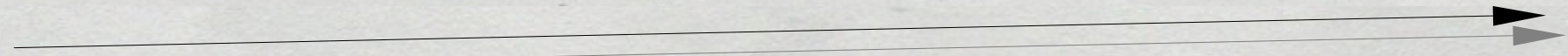
$$\sigma_v = [7 \ 5 \ 6 \ 8 \ 3 \ 4 \ 1 \ 2 \ 9]$$
$$v = [2 \ 3 \ 3 \ 1 \ 5 \ 4 \ 6 \ 6 \ 1]$$

$$\overleftarrow{v} = [6 \ 6 \ 5 \ 4 \ 3 \ 3 \ 2 \ 1 \ 1]$$

$$\overleftarrow{\sigma}_v = [2 \ 3 \ 3 \ 1 \ 5 \ 4 \ 6 \ 6 \ 1]$$

Vector valued polynomials 3

Dominance

\prec : classical dominance order

$$\sigma \prec \sigma' \Leftrightarrow$$

$$\forall i, \sigma[1] + \dots + \sigma[i] \leq \sigma'[1] + \dots + \sigma'[i]$$

$$\sigma \triangleleft \sigma' \Leftrightarrow \begin{matrix} \uparrow \sigma & \prec & \uparrow \sigma' \\ \sigma & = & \sigma' \end{matrix} \text{ and } \sigma \prec \sigma'$$

Vector valued polynomials 3

Dominance

$$x^\sigma = x^{\sigma_1} \dots x^{\sigma_n}$$

$$x^{\sigma, \tau} := x^\sigma \otimes x^\tau$$

$$M_\lambda = \text{Span} \{ x^{\sigma, \tau} \}$$

$$x^{\sigma, \tau} \triangleleft x^{\sigma', \tau'} \iff \sigma \triangleleft \sigma' \text{ and } \tau \triangleleft \tau'$$

Vector valued polynomials 3

Dominance

$$x^{031, \overset{2}{3}1} \triangleleft x^{310, \overset{1}{3}2} \quad (031 \prec 310)$$

$$x^{220, \overset{2}{3}1} \triangleleft x^{301, \overset{1}{3}2} \quad (220 \prec 310)$$

$$x^{031, \overset{2}{3}1} \quad x^{031, \overset{1}{3}2} \quad \text{not comparable.}$$

Dunkl and Cherednik operators

Definitions

Divided differences

$$\partial_{i,j} = (1 - (i,j)) \frac{1}{x_i - x_j}$$

Dunkl operators

$$D_i := \frac{\partial}{\partial x_i} \oplus 1 + \frac{1}{q} \sum_{i \neq j} \partial_{ij} \oplus (i,j)$$

Cherednik elements

$$\tilde{y}_i = q x_i D_i - \sum_{j=1}^{i-1} (i,j) \oplus (i,j) - q$$

Dunkl and Cherednik operators

Cherednik and Jucys-Murphy elements

$$\begin{aligned} 1 \otimes z \cdot \sum_i \omega_i &= 1 \otimes z \cdot 1 \otimes \omega_i \\ &= C T_i [i] 1 \otimes z \end{aligned}$$

Dunkl and Cherednick operators

Intertwiners

$$(x, i+1) \oplus (i, i+1) \tilde{\xi}_i = \tilde{\xi}_{i+1} (x, i+1) \oplus (i, i+1) + 1$$

$$(x, i+1) \oplus (i, i+1) \tilde{\xi}_{i+1} = \tilde{\xi}_i (x, i+1) \oplus (i, i+1) - 1$$

$$(i, i+1) \oplus (x, i+1) \tilde{\xi}_j = \tilde{\xi}_j (x, i+1) \oplus (i, i+1)$$

$$j \neq i, i+1$$

Dunkl and Cherednick operators

Affine operation

$$\Theta = (1\ 2)(2\ 3)\cdots(N-1\ N)$$

$$\Psi := \Theta \otimes \Theta \cdot x_N$$

$$\Psi \sum_i \tilde{\epsilon}_i = \sum_{i+1} \tilde{\epsilon}_i \Psi, \quad i \neq N$$

$$\Psi \sum_N \tilde{\epsilon}_N = (\hat{\epsilon}_1 + \alpha) \Psi$$

Dunkl and Cherednick operators

Commutativity

$$[\tilde{\xi}_i, \tilde{\xi}_j] = 0$$

Dunkl and Cherednik operators

Compatibility with dominance

Handwritten mathematical notes on a piece of paper. A central expression is circled in pink and has a question mark above it. The expression is a sum over σ, z of $[i]$. To the left is $x^{\sigma, z}$ with a tilde and a subscript i . To the right is a sum over σ', z' of $\alpha_{\sigma', z'} x^{\sigma', z'}$.

$$x^{\sigma, z} \tilde{\sum}_i = \sum_{\sigma, z} [i] x^{\sigma, z} + \sum_{\sigma', z'} \alpha_{\sigma', z'} x^{\sigma', z'}$$

Dunkl and Cherednik operators

Monomial to zeta

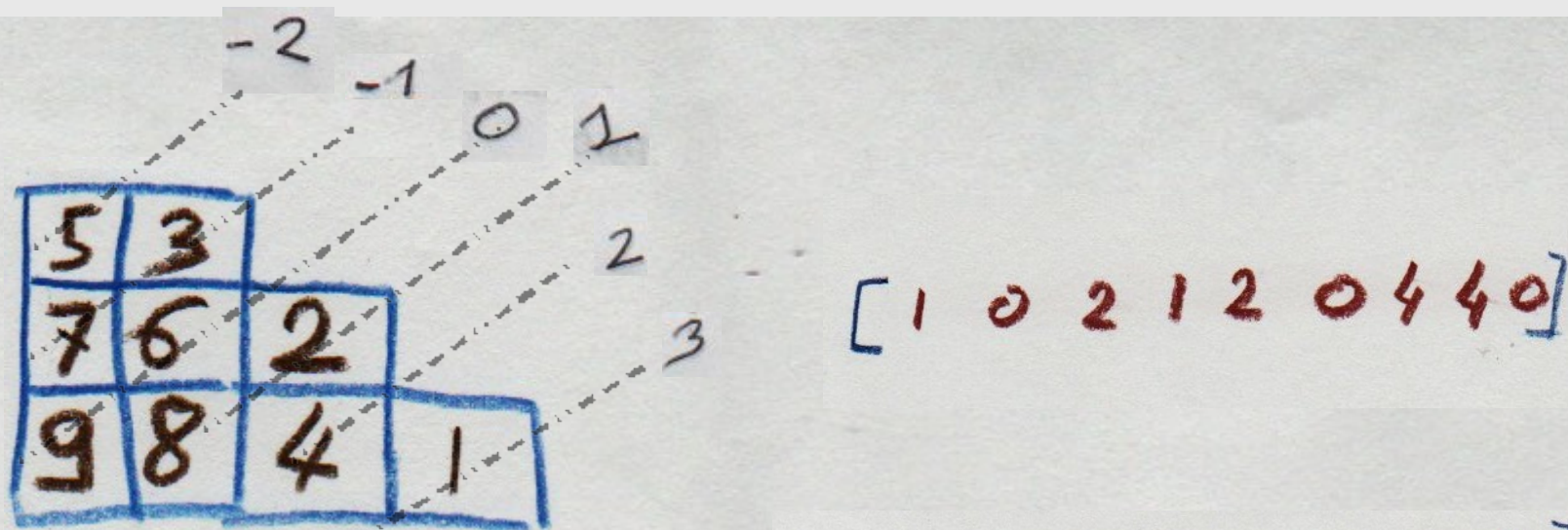

$$[1 \ 0 \ 2 \ 1 \ 2 \ 0 \ 4 \ 4 \ 0]$$

$$CT = [3 \ 1 \ -1 \ 2 \ -2 \ 0 \ -1 \ 1 \ 0]$$

$$\sigma_V = [4 \ 1 \ 6 \ 5 \ 7 \ 2 \ 8 \ 9 \ 3]$$

$$[2 \ 3 \ 0 \ -2 \ -1 \ 1 \ 1 \ 0 \ -1]$$

$$[\alpha \ 0 \ 2\alpha \ \alpha \ 2\alpha \ 0 \ 4\alpha \ 4\alpha \ 0]$$

$$CT \cdot \sigma_V + dU$$

$$\rho_{\sigma_V} =$$

$$[2+\alpha, 3, 2\alpha, \alpha-2, 2\alpha-1, 1, 4\alpha+1, 4\alpha, -1]$$

Dunkl and Cherednik operators

Zeta to monomial

5	3		
7	6	2	
9	8	4	1

$$\cdot \sigma^{-1} [3 \ 1 \ -1 \ 2 \ -2 \ 0 \ -1 \ 1 \ 0]$$

$$\sum_{\sigma \in \Sigma} -\alpha \nu = [2 \ 3 \ 0 \ -2 \ -1 \ 1 \ 1 \ 0 \ -1]$$

$$\sigma_{\nu}^{-1} = [2 \ 6 \ 9 \ 1 \ 4 \ 3 \ 5 \ 7 \ 8]$$

$$\sigma = [1 \ 0 \ 2 \ 1 \ 2 \ 0 \ 4 \ 4 \ 0]$$

$$\sum_{\sigma \in \Sigma} = [\alpha + 2, 3, 2\alpha, \alpha - 2, 2\alpha - 1, 1, 4\alpha + 1, 4\alpha - 1]$$

Dunkl and Cherednik operators

Zeta to monomial

5	3		
7	6	2	
9	8	4	1

$$\cdot \sigma^{-1} [3 \ 1 \ -1 \ 2 \ -2 \ 0 \ -1 \ 1 \ 0]$$

$$\sum_{\sigma \in \Sigma} - \alpha \nu = L$$

α generic $\Rightarrow \sum_{\sigma \in \Sigma}$ pairwise distinct

$$[3 \ 5 \ 7 \ 8]$$

$$\sigma = [1 \ 0 \ 2 \ 1 \ 2 \ 0 \ 4 \ 4 \ 0]$$

$$\sum_{\sigma \in \Sigma} = [\sigma = [1 \ 0 \ 2 \ 1 \ 2 \ 0 \ 4 \ 4 \ 0]$$

Jack Polynomials

Definition and existence

Proposition:

It exists a basis $(J_{\nu, \alpha})_{\nu, \alpha}$
of M_λ verifying:

$$- J_{\nu, \alpha} = x^{\nu, \alpha} + \sum_{\substack{\mu < \nu \\ x^{\mu, \alpha} \triangleleft x^{\nu, \alpha}}} a_{\mu, \nu} x^{\mu, \alpha}$$

$$- J_{\nu, \alpha} \tilde{\xi}_i = \sum_{\nu \frac{\alpha}{z}} [\nu \frac{\alpha}{z}] J_{\nu, \alpha}$$

Jack Polynomials

Definition and existence

Proof

From commutativity

+

compatibility with dominance

Jack Polynomials

Definition and existence

$$J_{\sigma, \alpha} = \text{Jack}$$

$\lambda=[n]$ (trivial representation) \Rightarrow "classical" Jack polynomials

Intertwiners

$$\square_{\lambda}^{\nu, \bar{\nu}} := (\lambda, \lambda+1) \otimes (\lambda, \lambda+1) + \frac{1}{\sum_{\nu, \bar{\nu}} [\lambda+1] - \sum_{\nu, \bar{\nu}} [\lambda]}$$

Intertwiners

Action of the symmetric group on pairs (v, τ)

	$v[i] \neq v[i+1]$	$v[i] = v[i+1], b_\tau[\sigma_v[i]] < 1$	$v[i] = v[i+1], b_\tau[\sigma_v[i]] = 1$
$(v, \tau).(i, i+1)$	$(v.(i, i+1), \tau)$	$(v, \tau^{\sigma_v[i], \sigma_v[i]+1})$	(v, τ)
$\zeta_{v, \tau}.(i, i+1)$	$\zeta_{v.(i, i+1), \tau}$	$\zeta_{v, \tau(\sigma_v[i], \sigma_v[i]+1)}$?
$J_{v, \tau}.\square_i^{v, \tau}$	$J_{v.(i, i+1), \tau}$	$J_{v, \tau(i, i+1)}$	0

Intertwiners

Action of the symmetric group on

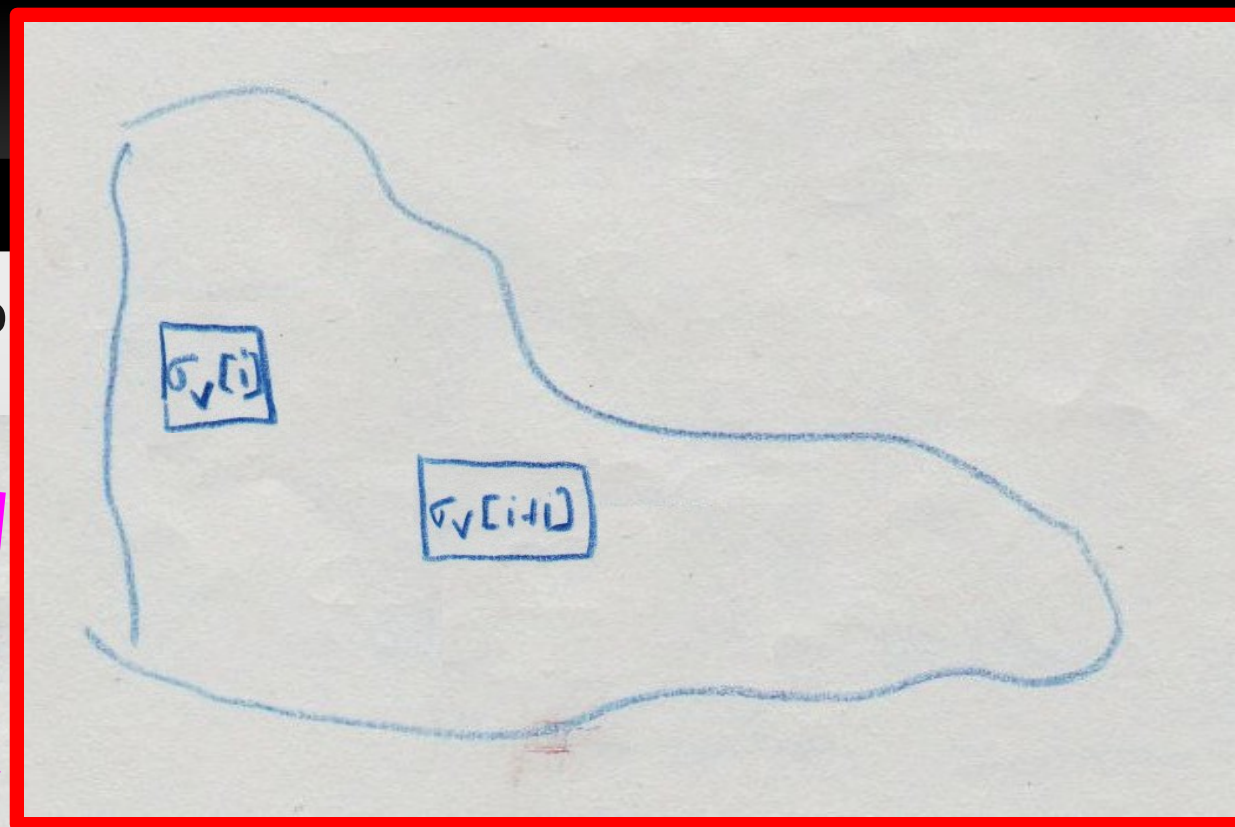

	$v[i] \neq v[i+1]$	$v[i] = v[i+1], b_\tau[\sigma_v[i]] < 1$	$v[i] = v[i+1], b_\tau[\sigma_v[i]] = 1$
$(v, \tau) \cdot (i, i+1)$	$(v \cdot (i, i+1), \tau)$	$(v, \tau^{\sigma_v[i], \sigma_v[i+1]})$	(v, τ)
$\zeta_{v, \tau} \cdot (i, i+1)$	$\zeta_{v \cdot (i, i+1), \tau}$	$\zeta_{v, \tau(\sigma_v[i], \sigma_v[i+1])}$?
$J_{v, \tau} \cdot \square_i^{v, \tau}$	$J_{v \cdot (i, i+1), \tau}$	$J_{v, \tau(i, i+1)}$	0

Intertwin

Action of the symm

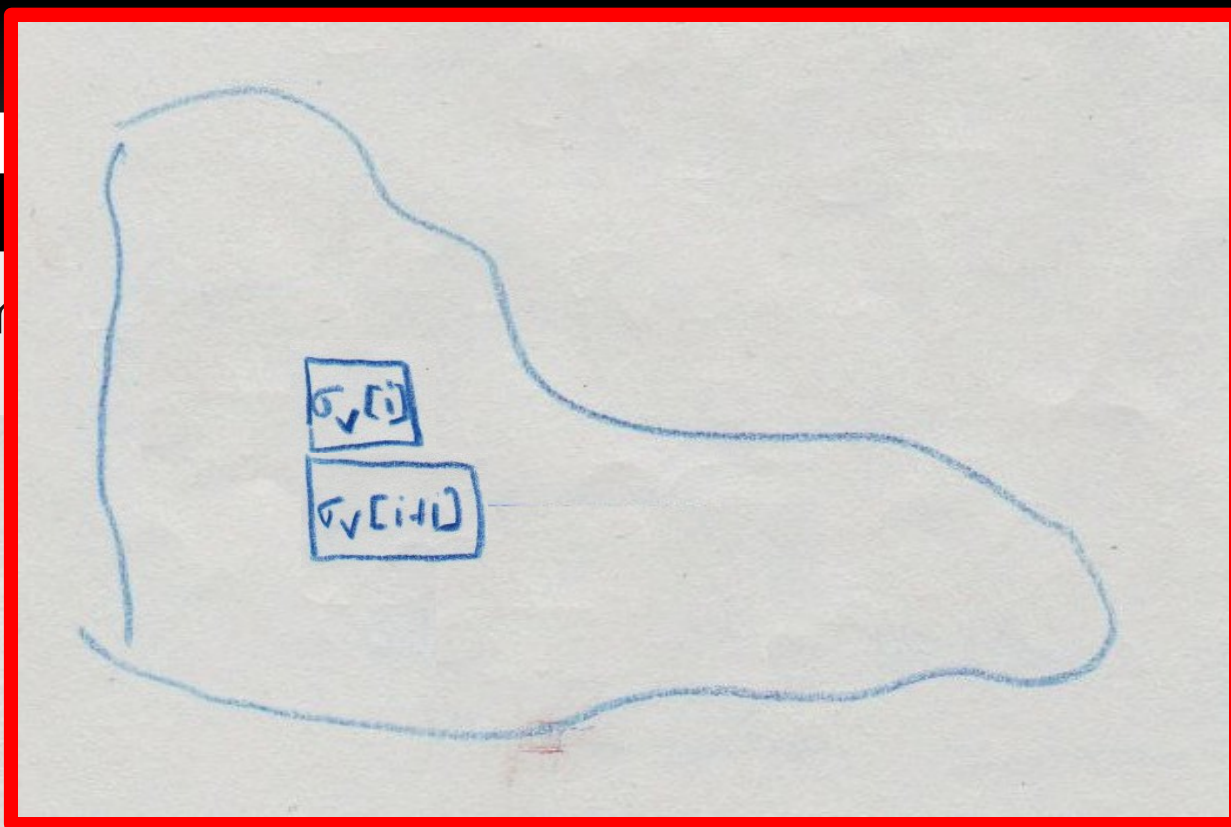

	$v[i] \neq v[i+1]$	$v[i] = v[i+1], b_\tau[\sigma_v[i]] < 1$	$v[i] = v[i+1], b_\tau[\sigma_v[i]] = 1$
$(v, \tau).(i, i+1)$	$(v.(i, i+1), \tau)$	$(v, \tau^{\sigma_v[i], \sigma_v[i+1]})$	(v, τ)
$\zeta_{v, \tau}.(i, i+1)$	$\zeta_{v.(i, i+1), \tau}$	$\zeta_{v, \tau(\sigma_v[i], \sigma_v[i+1])}$?
$J_{v, \tau}.\square_i^{v, \tau}$	$J_{v.(i, i+1), \tau}$	$J_{v, \tau(i, i+1)}$	0

Intertwiners

Action of the symmetric group on pairs (v, τ)

	$v[i] \neq v[i+1]$	$v[i] = v[i+1], b_\tau[\sigma_v[i]] < 1$	$v[i] = v[i+1], b_\tau[\sigma_v[i]] = 1$
$(v, \tau).(i, i+1)$	$(v.(i, i+1), \tau)$	$(v, \tau^{\sigma_v[i], \sigma_v[i]+1})$	(v, τ)
$\zeta_{v, \tau}.(i, i+1)$	$\zeta_{v.(i, i+1), \tau}$	$\zeta_{v, \tau(\sigma_v[i], \sigma_v[i]+1)}$?
$J_{v, \tau}.\square_i^{v, \tau}$	$J_{v.(i, i+1), \tau}$	$J_{v, \tau(i, i+1)}$	0

Intertwiners

Action of the symmetric group on pairs (v, τ)

	$v[i] \neq v[i+1]$	$v[i] = v[i+1], b_\tau[\sigma_v[i]] < 1$	$v[i] = v[i+1], b_\tau[\sigma_v[i]] = 1$
$(v, \tau).(i, i+1)$	$(v.(i, i+1), \tau)$	$(v, \tau^{\sigma_v[i], \sigma_v[i+1]})$	(v, τ)
$\zeta_{v, \tau}.(i, i+1)$	$\zeta_{v.(i, i+1), \tau}$	$\zeta_{v, \tau(\sigma_v[i], \sigma_v[i+1])}$?
$J_{v, \tau} \cdot \square_i^{v, \tau}$	$J_{v.(i, i+1), \tau}$	$J_{v, \tau(i, i+1)}$	0

$$\zeta_{(v, \tau).(i, i+1)} = \zeta_{(v, \tau)(i, i+1)}$$

$$\square_i^{v, \tau} = \sum_{i+1}^{i+1} (i, i+1) \otimes (i, i+1) + 1 + \frac{\sum_{i+1}^{i+1} \zeta_i}{\sum_{i+1}^{i+1} \zeta_i - \sum_{i+1}^{i+1} \zeta_i}$$

$$(J_{v, \tau} \square_i^{v, \tau}) \zeta_i = \sum_{v, \tau} \zeta_{i+1} (J_{v, \tau} \square_i^{v, \tau})$$

Intertwiners

Action of the symmetric group on pairs (v, τ)

	$v[i] \neq v[i+1]$	$v[i] = v[i+1], b_\tau[\sigma_v[i]] < 1$	$v[i] = v[i+1], b_\tau[\sigma_v[i]] = 1$
$(v, \tau).(i, i+1)$	$(v.(i, i+1), \tau)$	$(v, \tau^{\sigma_v[i], \sigma_v[i+1]})$	(v, τ)
$\zeta_{v, \tau}.(i, i+1)$	$\zeta_{v.(i, i+1), \tau}$	$\zeta_{v, \tau(\sigma_v[i], \sigma_v[i+1])}$?
$J_{v, \tau} \cdot \square_i^{v, \tau}$	$J_{v.(i, i+1), \tau}$	$J_{v, \tau(i, i+1)}$	0

$J_{\sigma_\tau} \square_i^{v, \tau}$ simultaneous eigenfunction
 of the ζ_i 's.
 Spectral vector: $J_{\sigma_\tau}(i, i+1) = \zeta_{(v, \tau)(i, i+1)}$

Intertwiners

Intertwiners and Jack polynomials

$$J_{\sigma, \tau} \square_i^{\sigma, \tau} = (*) J_{(\sigma, \tau)}(\lambda, a+1)$$

$$(*) = 1 \text{ when } \begin{array}{l} \sigma[\lambda] < \sigma[\lambda+1] \\ \text{or } \left(\begin{array}{l} \sigma[\lambda] = \sigma[\lambda+1] \\ \text{and} \\ \epsilon > -1 < b_{\tau}[\lambda] < 0 \end{array} \right) \end{array}$$

$$(*) = 0 \text{ when } \begin{array}{l} \sigma[\lambda] = \sigma[\lambda+1] \\ b_{\tau}[\lambda] = \pm 1 \end{array}$$

Affine Action

$$\Psi = \ominus \oplus \ominus x_N$$

$$\sigma \Psi_a := [\sqrt{2}, \dots, \sqrt{N}, \sigma_1 + a]$$

$$(\sigma, \bar{z}) \Psi := (\sigma \Psi_1, \bar{z})$$

Affine Action

$(v, \tau). \Psi$	$(v. \Psi, \tau)$
$\zeta_{v, \tau}. \Psi_\alpha$	$\zeta_{v. \Psi, \tau}$
$J_{v, \tau}. \theta \otimes \theta x_N$	$J_{v. \Psi, \tau}$

$$\Psi \sum_N^2 = \left(\sum_1^2 + \alpha \right) \Psi$$

$$\left(J_{\sigma_2} \Psi \right) \sum_N^2 = \left(\sum_{\sigma_2}^2 [1] + \alpha \right) \left(J_{\sigma_2} \Psi \right)$$

$$\left(J_{\sigma_2} \Psi \right) \sum_N^2 = \left(\sum_{\sigma_2}^2 [1] + \alpha \right) \left(J_{\sigma_2} \Psi \right)$$

Affine Action

$(v, \tau) \cdot \Psi$	$(v \cdot \Psi, \tau)$
$\zeta_{v, \tau} \cdot \Psi_\alpha$	$\zeta_{v \cdot \Psi, \tau}$
$J_{v, \tau} \cdot \theta \otimes \theta x_N$	$J_{v \cdot \Psi, \tau}$

$(J_{v, \tau} \Psi)$ sim. eigenfunction
of the ξ_j 's

Spectral vector : $\xi_{v, \tau} \Psi = \xi_{(v, \tau)} \Psi$

Affine Action

Jack polynomials

$$J_{\sigma, \tau} \psi = (*) J_{(\sigma, \tau)} \psi = (*) J_{\sigma} \psi_{\tau, \bar{\tau}}$$

$$(*) = 1$$

Yang Baxter Graph

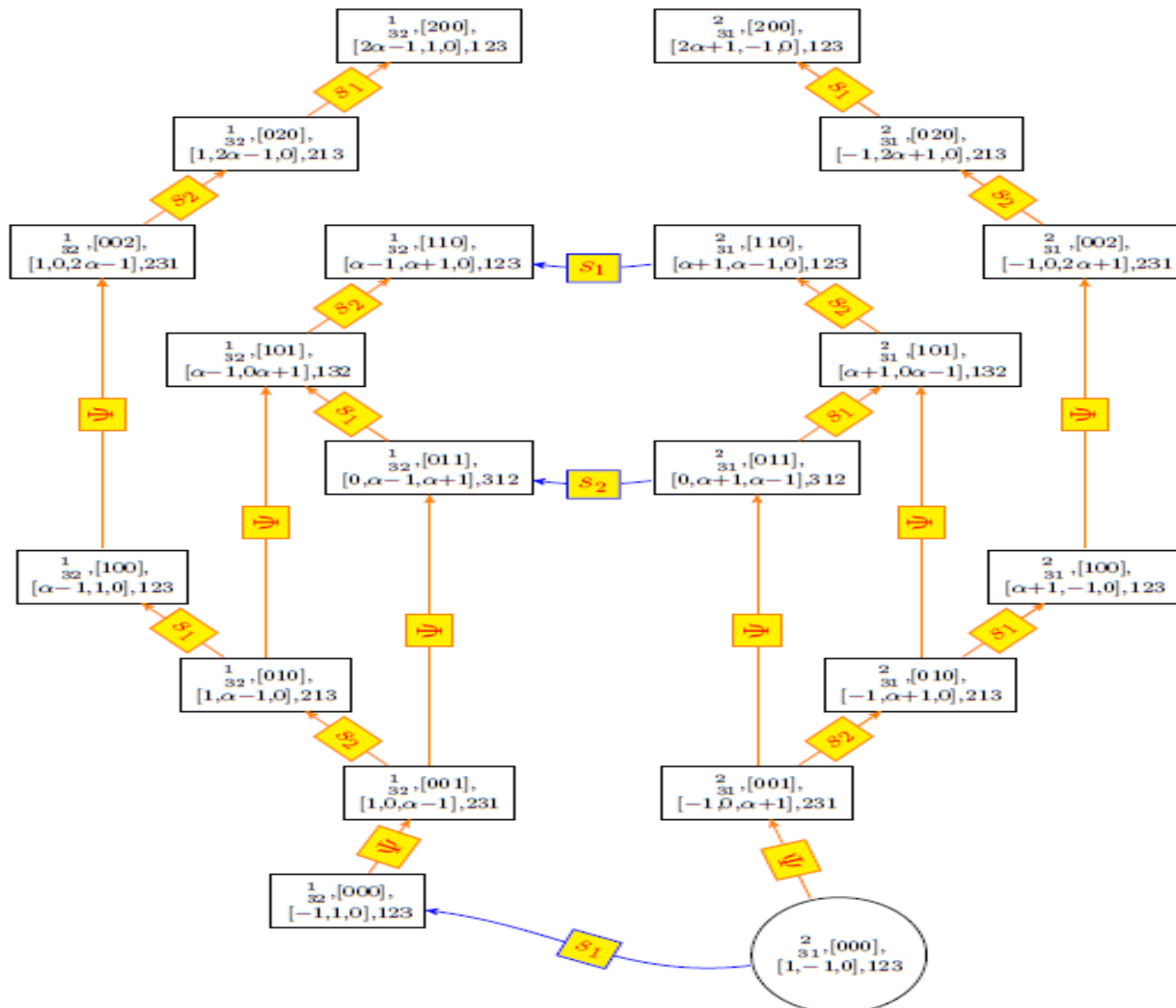

Yang Baxter Graph

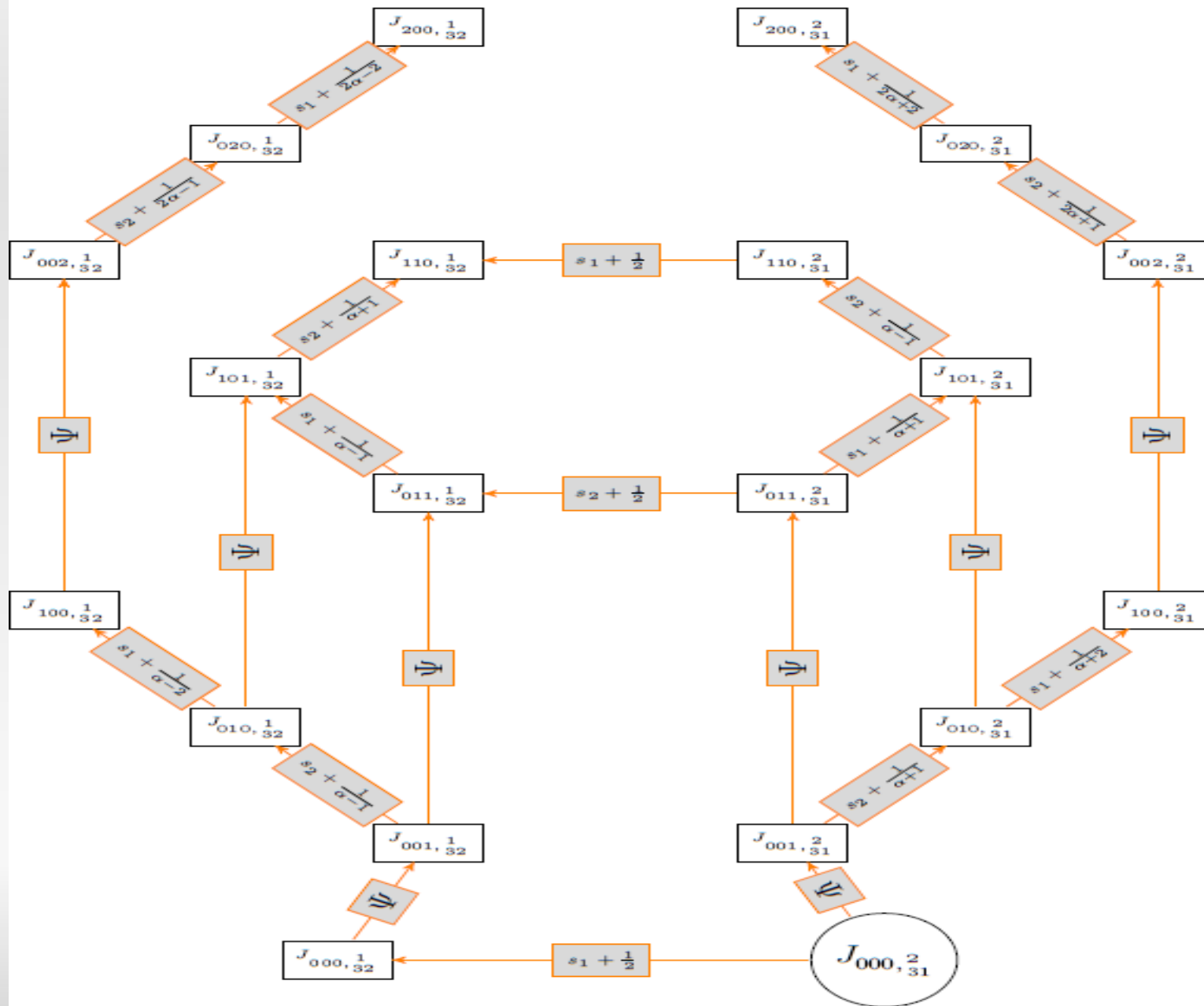

Application 1: Norm

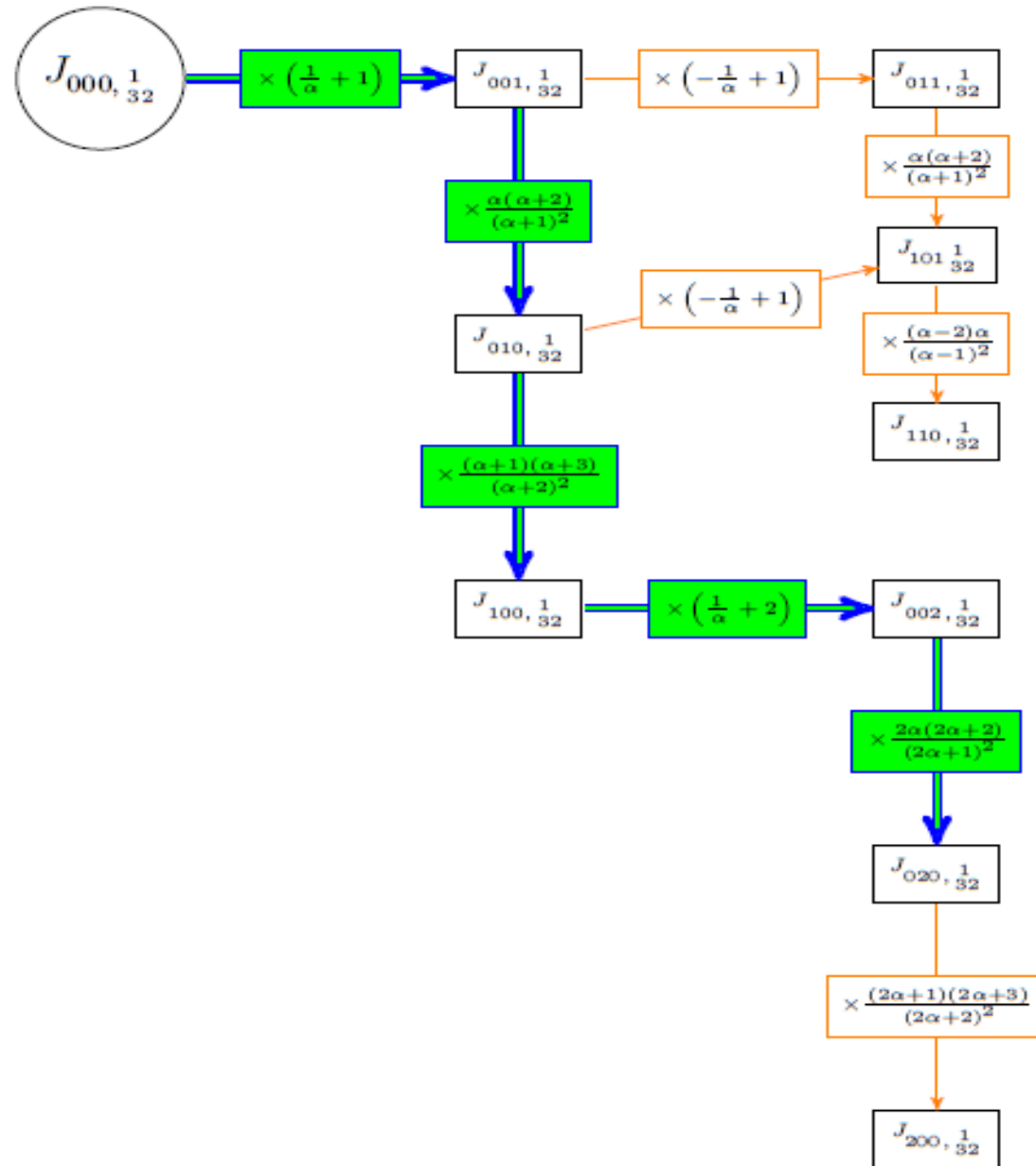

Application 2: Symmetrization

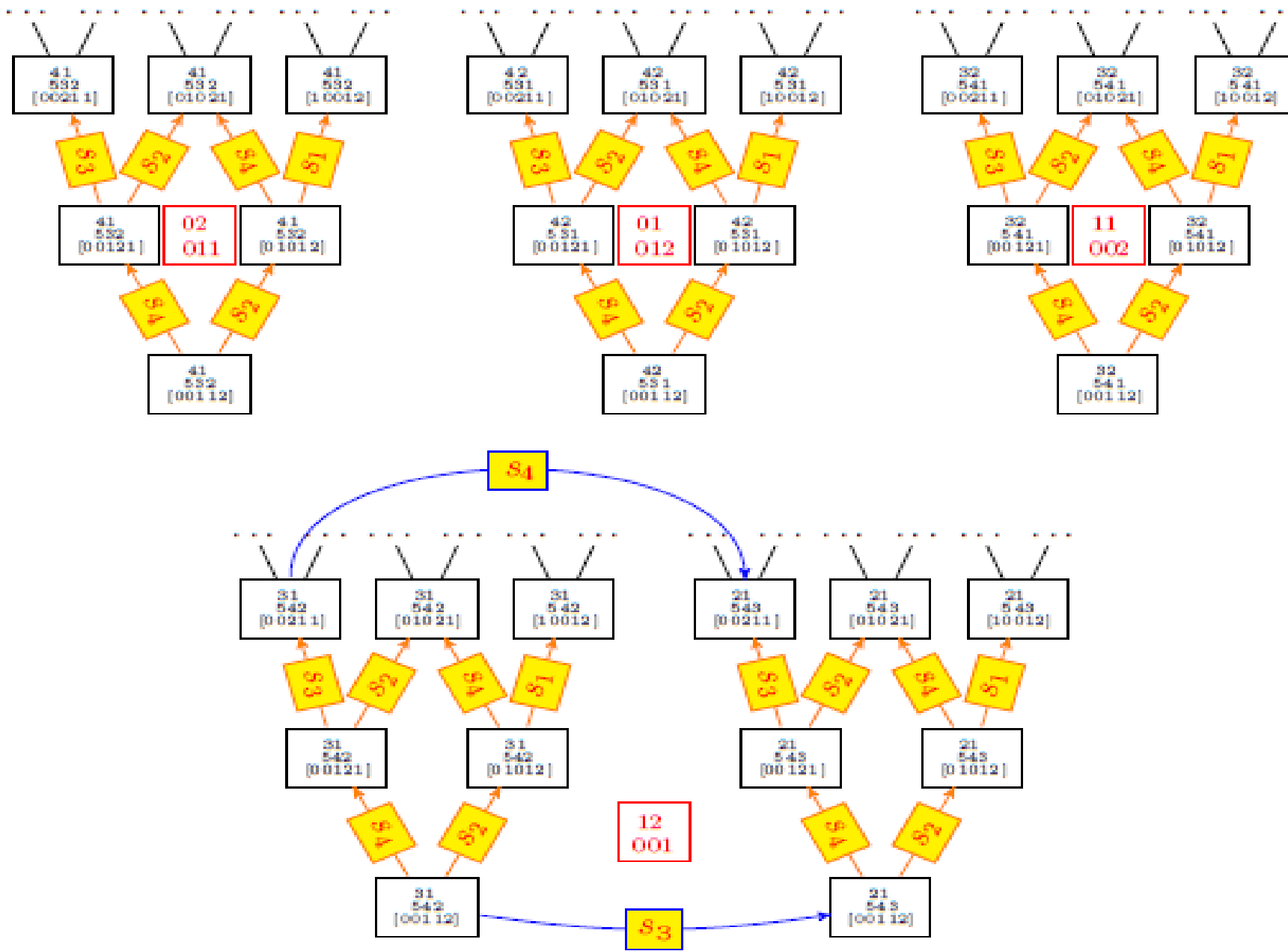

Application 2: Symmetrization

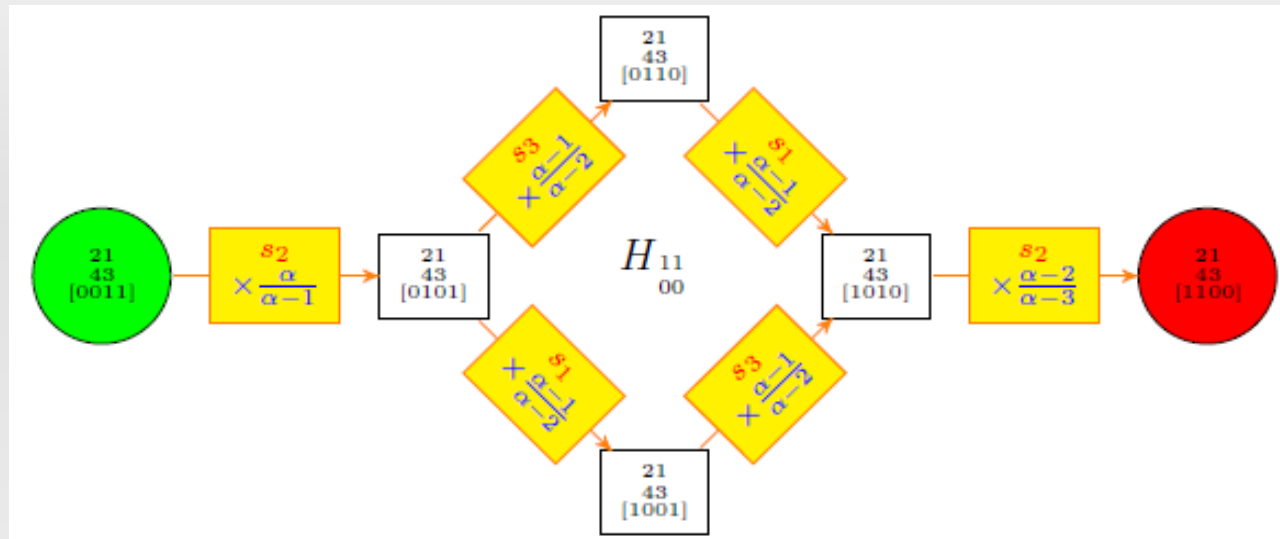

$$J_{11\ 00} = J_{0011, 21, 43} + \frac{\alpha}{\alpha-1} J_{0101, 21, 43} + \frac{\alpha}{\alpha-2} J_{0110, 21, 43} + \frac{\alpha}{\alpha-2} J_{1001, 21, 43} + \frac{\alpha(\alpha-1)}{(\alpha-2)^2} J_{1010, 21, 43} + \frac{\alpha(\alpha-1)}{(\alpha-2)(\alpha-3)} J_{1100, 21, 43}$$

Application 3: Restrictions

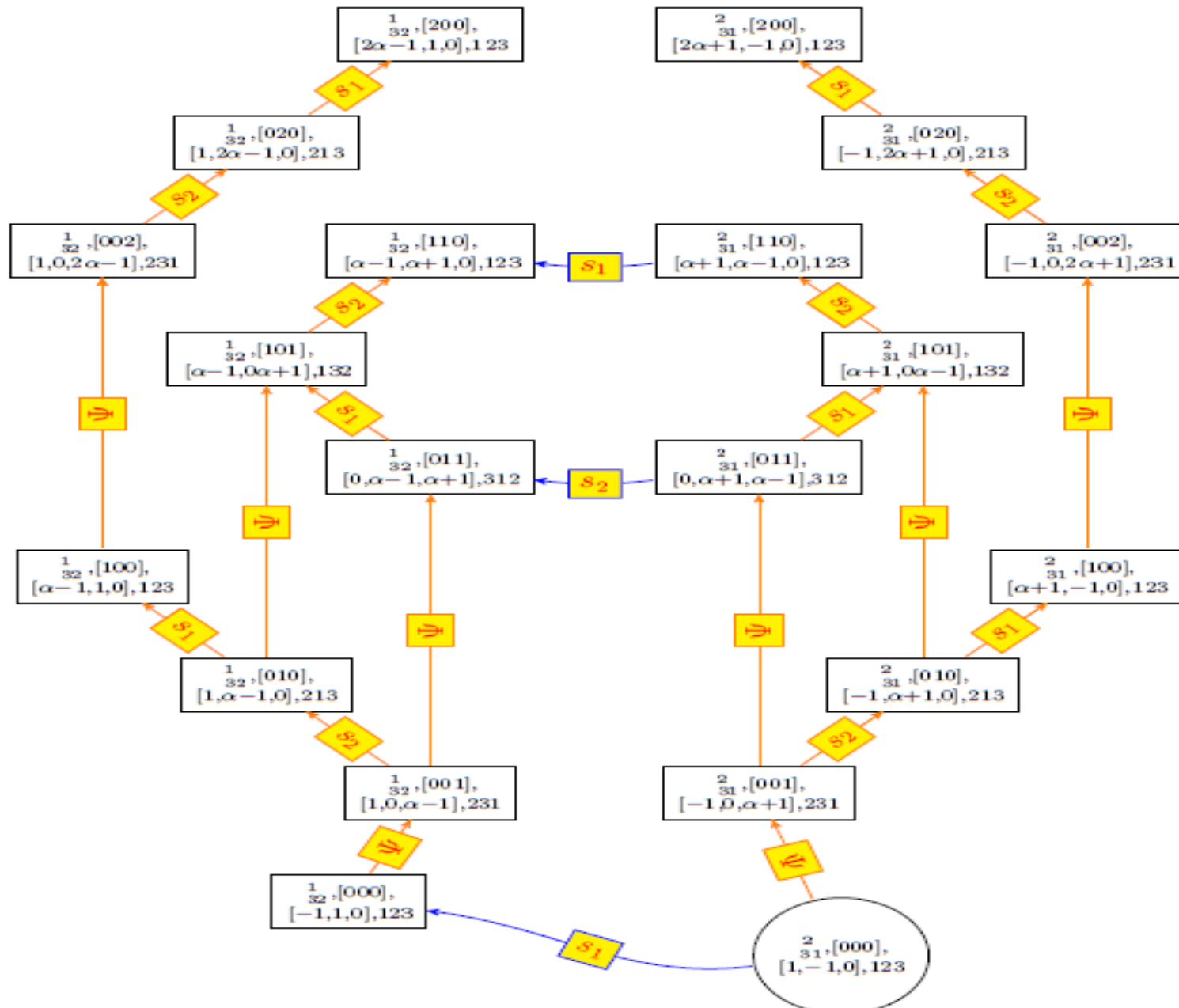

Application 3: Restrictions

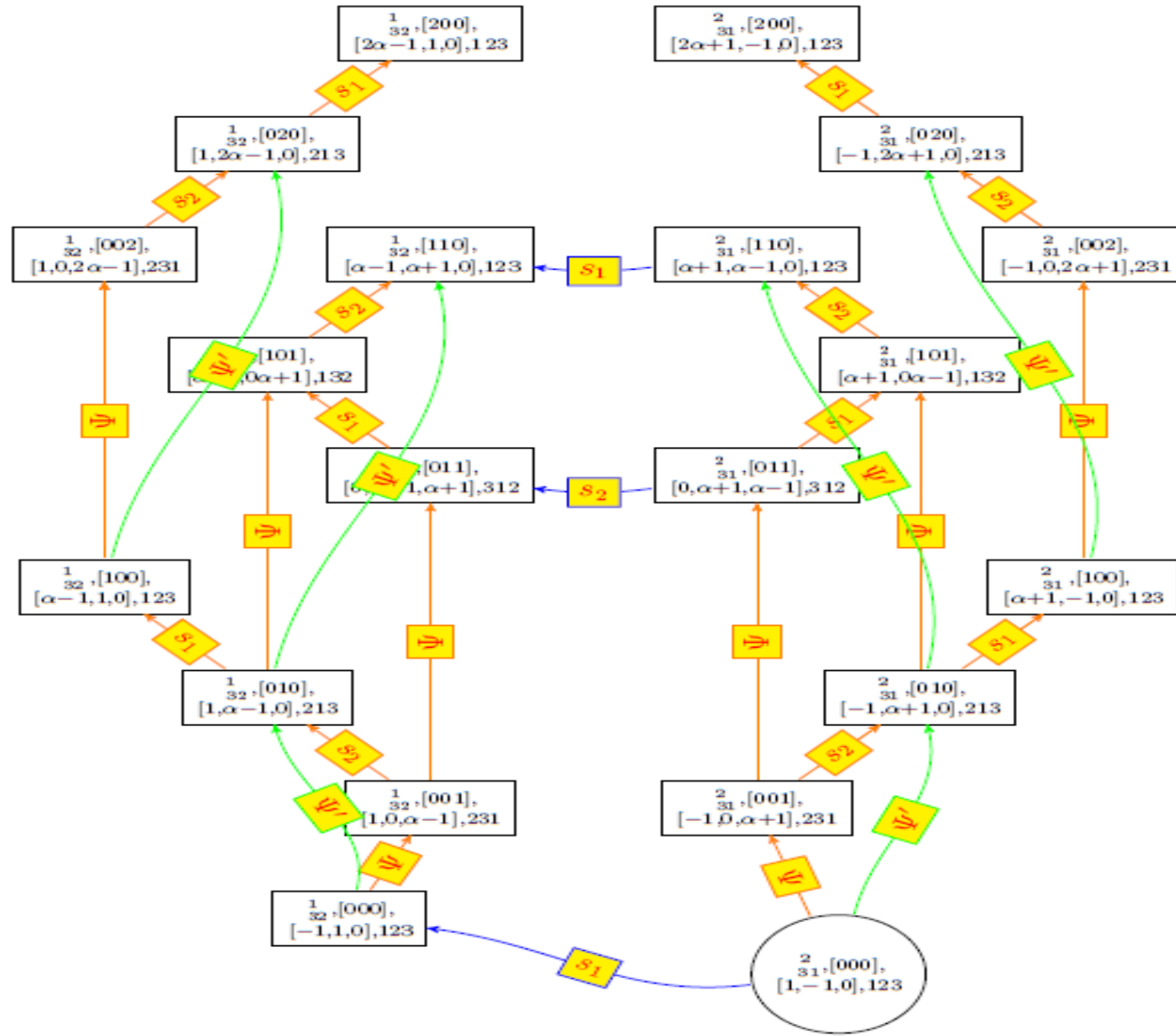

Application 3: Restrictions

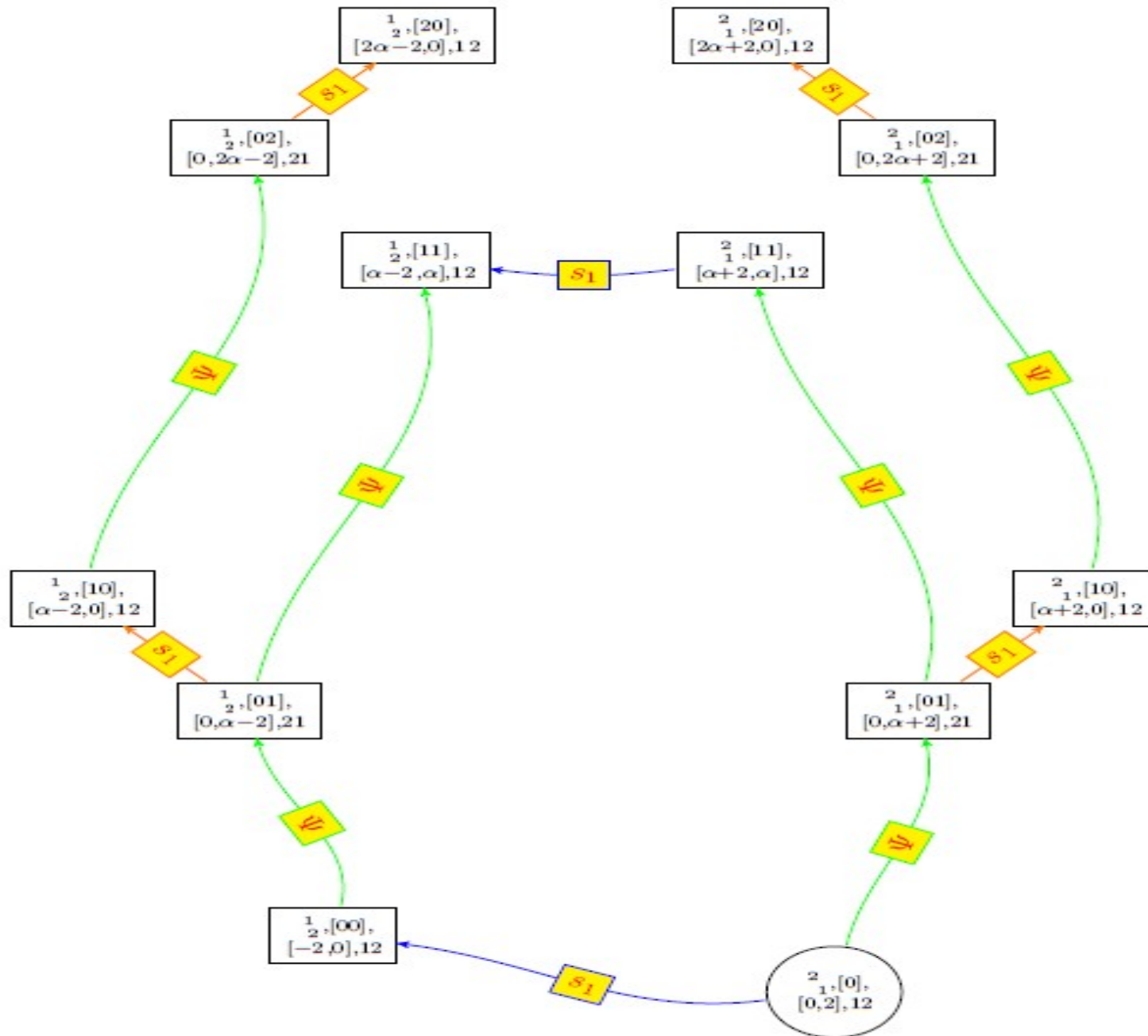

Application 3: Restrictions

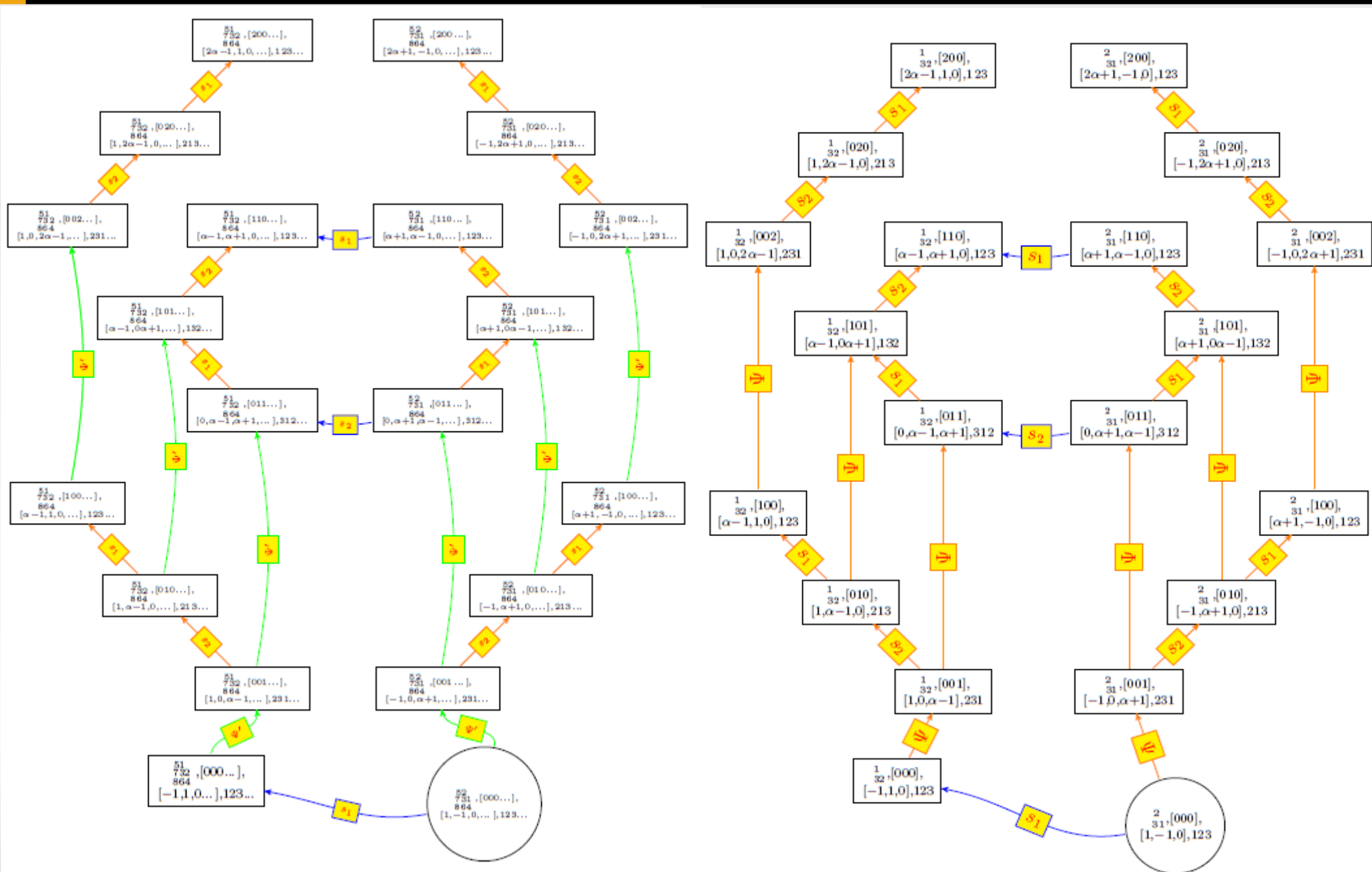

Application 3: Restrictions

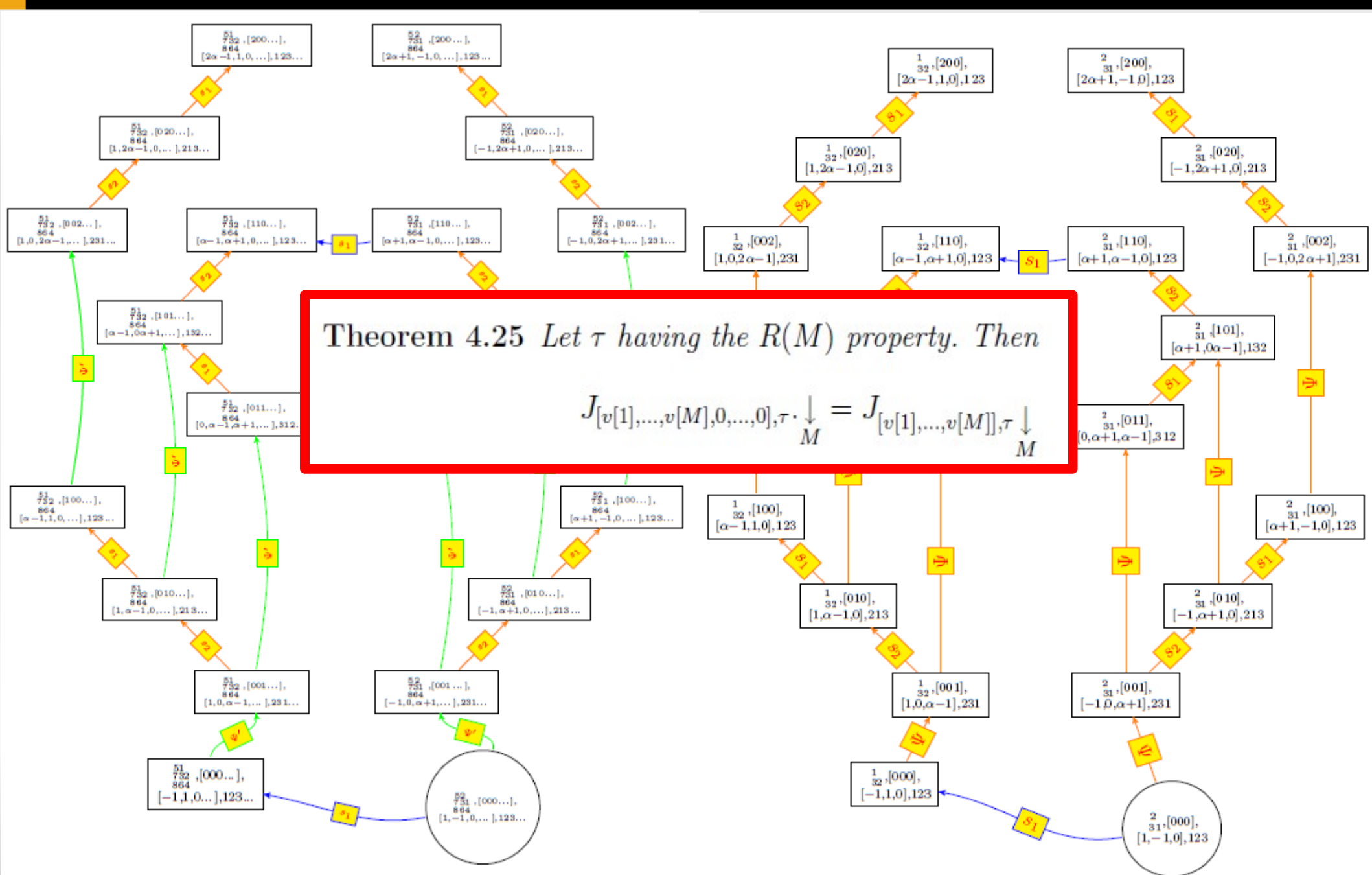

To Do !

- Shifted version (done)
- What about the other reflection groups $G(p,r,N)$
- Reproducing Kernel
- Action of the Dunkl operators
- Rational values of the parameter
- Macdonald?
- Applications :
 - Selberg Like integrals,
 - Applications to Physics