

The rotation correspondence is asymptotically a dilatation

Jean-François Marckert

Université de Versailles St-Quentin
Département de Mathématiques
45 Avenue des États Unis
78035 Versailles Cedex
marckert@math.uvsq.fr

Abstract

The rotation correspondence is a map that sends the set of plane trees onto the set of binary trees. In this paper, we first show that when n goes to $+\infty$, the image by the rotation correspondence of a uniformly chosen random plane tree τ with n nodes is close to 2τ (in a sense to be defined). The second part of the paper is devoted to the right and left depth of nodes in binary trees. We show that the empiric measure (suitably normalized) associated with the difference of the right depth and the left depth processes converges to the integrated super Brownian excursion.

1 Plane trees, binary trees and the rotation correspondence

In this paper, we call *plane tree* a finite rooted unlabeled loop-free connected graph in which the set of children of every vertex is endowed with a total order. We denote by T_P^n the set of plane trees having n nodes. A plane tree is called a binary tree if each node has zero or two children; a node with two children is said to be internal, otherwise is called a leaf. We denote by T_B^n the set of binary trees having $2n + 1$ nodes (hence n internal nodes). The cardinalities of T_P^{n+1} and T_B^n are the n th Catalan number (see [7] p.114 and 226), that is,

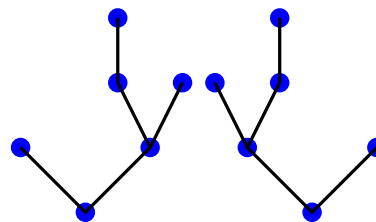

Figure 1: Two different plane trees.

$$\#T_P^{n+1} = \#T_B^n = \frac{(2n)!}{n!(n+1)!}.$$

1.1 Canonical labeling of a tree

Depth first search on the trees

Let τ be a plane tree and $|\tau|$ its number of nodes. We define the depth first search as a function (see Aldous [1] p.260):

$$f : \{0, \dots, 2|\tau| - 2\} \longrightarrow \{\text{nodes of } \tau\},$$

which we regard as a walk around τ , as follows:

- The starting point of the walk is the root: $f(0) = \text{root}$.
- Assume $f(i) = v$. If all children of v have been visited let $f(i + 1)$ be the father of v . Otherwise let w be the leftmost unvisited child of v and set $f(i + 1) = w$.

Depth first order on the trees

The depth first procedure induces an order on the set of nodes of τ : if u and v are two nodes of τ , one says that u is smaller than v for the depth first order if the first visit at u by the depth first search occurs before the first visit at v .

Lexicographical labeling of a tree

We label the nodes of a plane tree with words on the alphabet $\mathbb{N}^+ = \mathbb{N} \setminus \{0\}$:

- the root is labeled by the empty word ϵ .
- the d children of a node v are labeled $v1, v2, \dots, vd$ according to their order (the convention for the children of the root is $\epsilon a = a$).

We denote by \mathbb{U} the set of finite words on the alphabet \mathbb{N}^+ . For u and v in \mathbb{U} , denote by uv the concatenation of the words u and v . Denote by $L(\tau)$ the set of labels assigned to the tree τ . Hence, $L(\tau)$ is a subset of \mathbb{U} and it satisfies the following two points:

- (i) if uv is in $L(\tau)$ for $\{u, v\} \subset \mathbb{U}$ then u is in $L(\tau)$ (this translates the fact that the ancestors of a node w are in the tree and are labeled by the prefixes of the label of w).
- (ii) if ua is in $L(\tau)$ for $u \in \mathbb{U}$ and $a \in \mathbb{N}^+$ then $u1, \dots, ua$ are in $L(\tau)$ (this translates the fact that the b children of v are labeled from $v1$ to vb).

Moreover, for any subset L of \mathbb{U} containing ϵ and satisfying (i) and (ii), there exists a unique tree τ such that $L(\tau) = L$. The classical notions of brother, father, leftmost brother, rightmost brother of a node v can be easily translated in terms of words. For example, $v1$ is the leftmost son of v , and $v(a + 1)$ is the first brother on the right of va . In a binary tree, $v1$ (resp. $v2$) is the right (resp. left) son of v .

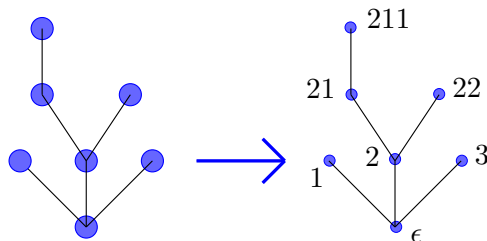

Figure 2: : Lexicographical labeling of a plane tree.

The lexicographical order and the depth first order are equivalent

Consider a tree τ and two of its nodes u and v . The following property is a straightforward consequence of the labeling procedure: if u is smaller than v for the depth first order then the label of u is smaller than the label of v for the lexicographical order.

In the rest of the paper, we identify a node v with its lexicographical label. We will say that a list of nodes is sorted, if it is sorted according to the depth first order.

1.2 The rotation correspondence

The *rotation correspondence* Φ is a map from the set of plane trees to the set of binary trees. It can be described by its action on T_P^{n+1} for $n \geq 0$:

$$\begin{aligned} \Phi : T_P^{n+1} &\longrightarrow T_B^n \\ \tau &\longmapsto \omega. \end{aligned}$$

To each node u of τ (the root excepted), there corresponds an internal node of ω , denoted $\Phi(u)$ and the following three points characterize ω :

- a) Let u be the leftmost son of the root of τ (its label is 1). We have $\Phi(u) = \epsilon$.
- b) $(\{v, w\} \subset L(\tau), w = v1) \iff (\{\Phi(v), \Phi(w)\} \subset L(\omega), \Phi(w) = \Phi(v)1)$.
- c) $(\{v, w\} \subset L(\tau), v = ua, w = u(a+1)) \iff (\{\Phi(v), \Phi(w)\} \subset L(\omega), \Phi(w) = \Phi(v)2)$.

The binary tree ω is then obtained by adding the leaves to this internal structure.

Remarks and interpretations:

- (b) means that the relation (*father – leftmost son*) in τ is translated by the relation (*father – left son*) in ω . (c) means that if w is the first brother on the right of v in τ then $\Phi(w)$ is the right son of $\Phi(v)$ in ω .
- During the construction of ω , no image is assigned to the root of τ .
- In the *internal* subtree of ω the relation *father – son* is either a relation *father – right son* or a relation *father – left son*.
- The rotation correspondence has a visual description as one can see on Figure 3. Remove the root of τ . Keep only the edges [father-leftmost son] and add an edge between each node and its first brother on its right if any (second step of Figure 3). Make a rotation of $\pi/4$ (third step). This gives the internal structure of the binary tree ω ; in the fourth step, add leaves to this internal structure.

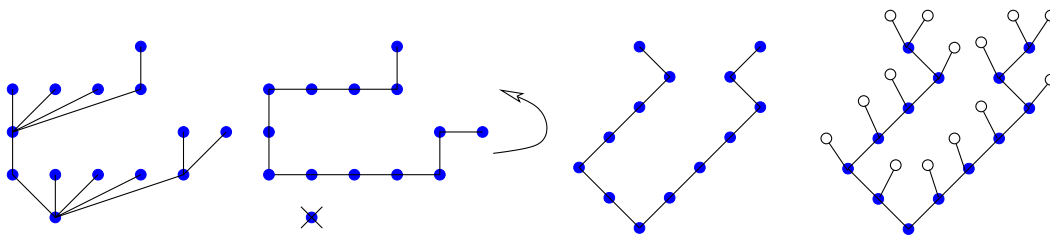

Figure 3: : Geometric rotation

In this paper, we study the relation between τ and ω . We show that, given a plane tree τ taken uniformly in T_P^{n+1} , the binary tree ω is almost 2τ (when n is large). Obviously, 2τ is not a well defined quantity; we will use associated processes to give a rigorous meaning to this multiplication. The proof of this phenomenon relies on the existence of a branching random walk inside binary trees; a random measure associated with this discrete branching random

walk will appear to be the right object to apprehend the distance between τ and ω . The weak limit of this random measure turns out to be ISE (the integrated super Brownian excursion, introduced by Aldous [2]). ISE is the limit measure of numerous arborescent random measures (for applications and further references, see [3, 5, 15]). An archetype of the occurrence of ISE in combinatorics is the work of Chassaing & Schaeffer [4]; they relate the diameter of planar maps to the range of ISE.

A first result is that Φ preserves the depth first order:

Lemma 1 (Φ preserves the depth first order) *Let τ be a tree in T_P^{n+1} and let (v_0, v_1, \dots, v_n) be the sorted list of its nodes. Let (w_0, \dots, w_{n-1}) be the sorted list of the internal nodes of $\Phi(\tau)$. One has*

$$\Phi(v_{i+1}) = w_i \quad \text{for any } i \in \llbracket 0, n-1 \rrbracket. \quad (1)$$

Proof: It is clear that the three operations (a, b, c) (of the rotation correspondence) induce the same depth order between two nodes and between their images by Φ . \square

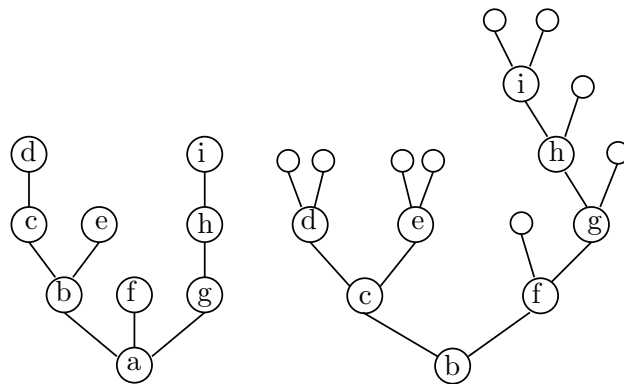

Figure 4: : Representation of the corresponding nodes under the rotation correspondence.

Conventions

- In the rest of the paper, we denote by v_i (resp. w_i) the i th node of a tree τ of $T_P^{(n+1)}$ (resp. the i th internal node of $\omega = \Phi(\tau)$). The node w_i is the image of v_{i+1} by the rotation correspondence. We will also denote by (z_0, \dots, z_{2n}) the sorted list of all the nodes of ω (including leaves).
- **(A unique probability space)** We endow T_B^n and T_P^{n+1} with the uniform distribution. Consider $\Psi = \Phi^{-1}$. The map Ψ is a measure preserving bijection between T_B^n and T_P^{n+1} . Hence, the random variables on T_P^{n+1} can be seen as random variables on T_B^n through Ψ . With this point of view it is then possible to work only on T_B^n . This allows us to study joint properties of ω and τ .
- We denote by $[a]$ the integral part of a and $\{a\}$ its fractional part.

2 Height processes

2.1 Definitions and recalls

Let T be a plane tree and y be one of its nodes. We denote by $h(y)$ the distance between the root and y in T . This distance is sometimes called the depth of the node y . Note $y_0, \dots, y_{|T|-1}$ the sorted list of the nodes of T . One calls the height sequence of T , the finite sequence defined by

$$H(i) = h(y_i) \quad \text{for } i \in \llbracket 0, |T| - 1 \rrbracket. \quad (2)$$

It is quite easy to check that the height sequence characterizes the tree. The *height process* is the continuous process with duration 1 that interpolates piecewise the height sequence. In other words, it is the process

$$h(y_{\lfloor (|T|-1)t \rfloor}) + \{(|T|-1)t\} (h(y_{\lfloor (|T|-1)t \rfloor + 1}) - h(y_{\lfloor (|T|-1)t \rfloor})) \quad \text{for } t \in [0, 1].$$

This process is compound with $|T| - 1$ *pieces* with size $(|T| - 1)^{-1}$ that each corresponds to the passage from a node to the following one by the depth first procedure.

Let ω and τ be two trees being in T_B^n and T_P^{n+1} respectively, and such that $\Psi(\omega) = \tau$. The *height processes* of ω and τ are respectively given by

$$H_n(t) = h(z_{\lfloor 2nt \rfloor}) + \{2nt\} (h(z_{\lfloor 2nt \rfloor + 1}) - h(z_{\lfloor 2nt \rfloor})) \quad \text{for } t \in [0, 1]$$

and

$$\mathcal{H}_n(t) = h(v_{\lfloor nt \rfloor}) + \{nt\} (h(v_{\lfloor nt \rfloor + 1}) - h(v_{\lfloor nt \rfloor})) \quad \text{for } t \in [0, 1].$$

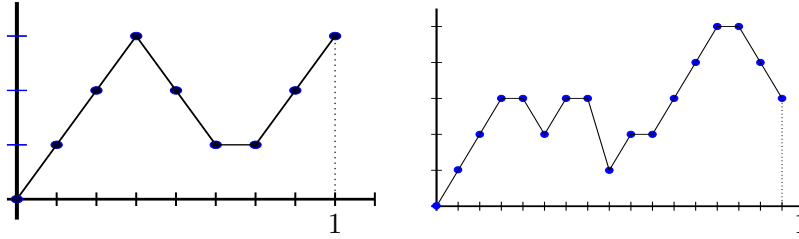

Figure 5: : Height processes of the trees of Figure 4

It is shown in Marckert & Mokkadem [12] that the following weak convergences hold in $(C[0, 1], \|\cdot\|_\infty)$:

$$\left(\frac{H_n(t)}{\sqrt{n}} \right)_{t \in [0, 1]} \xrightarrow[n]{\text{weakly}} (2^{3/2} e(t))_{t \in [0, 1]}, \quad (3)$$

$$\left(\frac{\mathcal{H}_n(t)}{\sqrt{n}} \right)_{t \in [0, 1]} \xrightarrow[n]{\text{weakly}} (2^{1/2} e(t))_{t \in [0, 1]}, \quad (4)$$

where $(e(t))_{t \in [0, 1]}$ is the normalized Brownian excursion (NBE). To obtain these results (using [12]), one has to note that the set T_B^n endowed with the uniform law is identical to the set of Galton-Watson trees with Bernoulli offspring distribution $p\delta_2 + (1-p)\delta_0$ conditioned to have n

internal nodes; the set T_P^{n+1} endowed with the uniform law is identical to the set of GW trees with geometric offspring distribution $\sum_{k \geq 0} p(1-p)^k \delta_k$ conditioned to have $n+1$ nodes.

The limit results (3) and (4) do not say anything about some possible links between \mathcal{H}_n and H_n . We fill this gap in the rest of the paper.

2.2 The right and the left (height) processes

Consider a node v of a tree ω in T_B^n . Denote by $r(v)$ (resp $l(v)$) the right depth of v (resp. the left depth of v), that is, the number of ancestors w of v such that v is in the right descendance of w (resp. left descendance of w). In other words, $r(v)$ is the number of right turns going from *root* to v (on Figure 4, one has $l(g) = 0, r(g) = 2, h(g) = 2$); for each node, one has:

$$l(v) + r(v) = h(v). \quad (5)$$

Lemma 2 *Let ω be in T_B^n . For any $i \in \llbracket 0, n-1 \rrbracket$,*

$$h(v_{i+1}) = l(w_i) + 1. \quad (6)$$

Note that in (6), the left-hand side deals with node v_{i+1} in $\tau = \Psi(\omega)$ when the right-hand side deals with node w_i in ω .

Proof: This well-known property of the rotation correspondence is a consequence of the following fact: “to climb one level” in τ is translated into “to go up by a left step” in ω (operation (b) that defines Φ). \square

For ω in T_B^n , the right height process, the right internal height process and the internal height process are defined by:

$$R_n(t) = r(z_{\lfloor 2nt \rfloor}) + \{2nt\} (r(z_{\lfloor 2nt \rfloor + 1}) - r(z_{\lfloor 2nt \rfloor})) \quad \text{for } t \in [0, 1], \quad (7)$$

$$R_n^I(t) = r(w_{\lfloor nt \rfloor - 1}) + \{nt\} (r(w_{\lfloor nt \rfloor}) - r(w_{\lfloor nt \rfloor - 1})) \quad \text{for } t \in [0, 1]. \quad (8)$$

$$H_n^I(t) = h(w_{\lfloor nt \rfloor - 1}) + \{nt\} (h(w_{\lfloor nt \rfloor}) - h(w_{\lfloor nt \rfloor - 1})) \quad \text{for } t \in [0, 1]. \quad (9)$$

We use the convention $h(w_{-1}) = r(w_{-1}) = l(w_{-1}) = 0$ for the first *artificial* piece of the internal processes. The left height process and left internal height process L_n and L_n^I are defined accordingly. By construction, these processes are elements of $C([0, 1], \mathbb{R}^+)$.

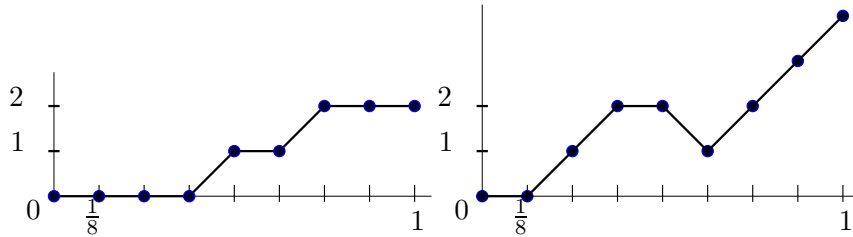

Figure 6: : R_n^I and H_n^I . The first piece $[0, 1/8]$ is artificial.

Remark: The time scales in R_n^I, L_n^I, H_n^I are slightly different from the expected ones. The reason is simple. The internal nodes of ω form a tree that has n nodes. We want to compare

this tree with τ that has $n + 1$ nodes. The result is that the corresponding height processes do not have the same number of pieces. Taking $\lfloor nt \rfloor - 1$ instead of $\lfloor (n - 1)t \rfloor$ in the time scale of the internal processes gives the suitable number of pieces. The price is the addition of a first null piece in the internal height processes. With this convention, one has for example that $\mathcal{H}_n(t) = L_n^I(t) + 1$ for any t which is useful in the proof of Theorem 3 and in the proof of Theorem 6.

2.3 Convergence of the height processes

Theorem 3 *Each of the processes $n^{-1/2}(2R_n)$, $n^{-1/2}(2R_n^I)$, $n^{-1/2}(2L_n)$, $n^{-1/2}(2L_n^I)$, $n^{-1/2}H_n$, $n^{-1/2}H_n^I$, and $n^{-1/2}(2\mathcal{H}_n)$ converges weakly in $(C[0, 1], \|\cdot\|_\infty)$ to $2^{3/2}e$ where e is the NBE. Moreover, the difference between any two of these processes converges weakly to the null process.*

Remarks : Theorem 3 ensures that the following limit holds in $(C[0, 1]^2, \|\cdot\|_\infty)$:

$$\left(\frac{2\mathcal{H}_n(t_1)}{\sqrt{n}}, \frac{H_n(t_2)}{\sqrt{n}} \right)_{(t_1, t_2) \in [0, 1]^2} \xrightarrow[n]{\text{weakly}} (2^{3/2}e(t_1), 2^{3/2}e(t_2))_{(t_1, t_2) \in [0, 1]^2}. \quad (10)$$

This is a refinement of (4). The important point is that the same NBE appears twice in the right-hand side of (10). In Theorem 6 (stated at the end of this section), we go further by measuring the distance between H_n and \mathcal{H}_n .

Proof of Theorem 3 : We would like first to stress that this theorem can be shown using only “old results”. First, thanks to (3) and (4), one just has to prove the second assertion of the theorem. Equation (6) ensures that $n^{-1/2}(\mathcal{H}_n - L_n^I)$ goes to 0. Equation (5) implies that

$$H_n = L_n + R_n \text{ and that } H_n^I = L_n^I + R_n^I. \quad (11)$$

In [12] (theorem 4), one finds the following result (translated in our notations): for any positive ν , there exist two constants $\gamma > 0$ and $N > 0$ such that

$$\forall n \geq N, \quad \mathbb{P}(\|H_n - H_n^I\|_\infty \geq n^{1/4+\nu}) \leq e^{-\gamma n^\nu}.$$

Taking $0 < \nu < 1/4$, one obtains that $n^{-1/2}(H_n - H_n^I)$ converges weakly to 0. Applying Theorem 2 of [14], we obtain that for any $\beta > 0$, there exists $\gamma > 0$ such that, for n large enough

$$\mathbb{P}\left(\sup_j |l(z_j) - r(z_j)| > \gamma n^{1/4} \ln n\right) = o(n^{-\beta}).$$

This implies that $n^{-1/2}(L_n - R_n)$ goes to 0 and $n^{-1/2}(L_n^I - R_n^I)$ also. Plugging these convergences in (11), one derives that $n^{-1/2}(H_n - 2R_n)$ and $n^{-1/2}(H_n^I - 2R_n^I)$ goes to 0 (and the same results hold replacing R_n by L_n). All the other differences can be written in terms of the ones shown above. \square

The convergence of $n^{-1/2}H_n$ and $n^{-1/2}(2\mathcal{H}_n)$ to the same NBE can also be proven using the fact that S_n , the Łukasiewicz walk (LW) of ω , is equal to the depth first walk of τ (also called the Harris walk [9] or the tour) (see exercise 5.42 p.262 in [7]). The relations obtained in [12] between the tour, the LW and the height process allow then to conclude.

3 The dilatation and ISE

The aim of the rest of the paper is to measure “the difference” between τ and ω . Theorem 5 and Theorem 6 (and particularly Formula (14)) allow to measure more precisely the distance between \mathcal{H}_n and the other processes.

For a tree u and a positive number c , we define cu as the tree having the same branching structure as u but with edge lengths c (the default length of edges being 1).

Theorem 4 *The pair of normalized trees $(2^{1/2}n^{-1/2}\tau, 2^{-1/2}n^{-1/2}\omega)$ converges to (T_∞, T_∞) where T_∞ is the continuum random tree.*

Proof: Aldous [1] shows that $2^{1/2}n^{-1/2}\tau$ and $2^{-1/2}n^{-1/2}\omega$ both weakly converge to the continuum random tree (the convergence to the continuum random tree is actually equivalent to the convergence of the normalized tour to $2e$). The fact that the two limit continuum random trees are the same one comes from (10); indeed, in [12], it is shown that the tour and the height process have the same limit. \square

Note on the title of the paper: Asymptotically, 2τ and ω are very close trees in the sense given by equation (10) and Theorem 4. This means that the map Φ on T_p^n , when n is large, is a good approximation of the dilatation with factor 2.

Theorem 5 *The limit difference between the right and left processes can be described in terms of the Brownian snake:*

$$\frac{1}{2n+1} \sum_{j=0}^{2n} \delta\left(\frac{L_n(\frac{j}{2n}) - R_n(\frac{j}{2n})}{2^{1/4}n^{1/4}}\right) \xrightarrow[n]{(d)} \mu_{ISE} \quad (12)$$

where $\delta(x)$ is the Dirac measure on the point x and where μ_{ISE} is the integrated super Brownian excursion. Moreover,

$$n^{-1/4} \|L_n - R_n\|_\infty \xrightarrow[n]{(d)} 2^{3/4}W \quad (13)$$

where W is the maximum of the absolute value of the Brownian snake with lifetime the NBE.

Some elements about W and μ_{ISE} are recalled in Subsection 3.1.

Theorem 6 *The limit difference between the processes \mathcal{H}_n and H_n^I can be described in terms of the Brownian snake:*

$$n^{-1/4} \|2\mathcal{H}_n - H_n^I\|_\infty \xrightarrow[n]{(d)} 2^{3/4}W. \quad (14)$$

Moreover

$$\frac{1}{n} \sum_{k=0}^{n-1} \delta\left(\frac{2\mathcal{H}_n(\frac{k}{n}) - H_n^I(\frac{k}{n})}{2^{1/4}n^{1/4}}\right) \xrightarrow[n]{(d)} \mu_{ISE}. \quad (15)$$

Interpretation of the results : Formulae (13) and (14) say that the distance between the processes is about $n^{1/4}$. Formulae (12) and (15) allow to measure all the distances between corresponding nodes in ω and $\Psi(\omega)$.

3.1 Finite branching random walks and ISE

Pick a tree ω at random in T_B^n . Now, with each node z_i of ω (for $i \in \llbracket 0, 2n \rrbracket$) associate a real number $y(z_i)$, called the value of z_i (we set $y(\text{root}) = 0$). Suppose now that the values are random variables that satisfy the following set of conditions:

- (i) values associated with non-brothers are independent.
- (ii) values are independent of the structure of the tree ω .
- (iii) if w and w' are brothers then

$$\mathbb{P}((y(w), y(w')) = (-1, +1)) = \mathbb{P}((y(w), y(w')) = (+1, -1)) = 1/2.$$

One has now a marked tree, say $M(\omega)$. The probability space $B(n)$ of such marked trees is

$$B(n) = T_B^n \times \{(-1, +1), (+1, -1)\}^n.$$

Indeed, for each of the n internal nodes, one simply has to choose the values of its two children. This construction induces the uniform distribution on $B(n)$: each marked tree from $B(n)$ has probability $2^{-n}(\#T_B^n)^{-1}$. Let a in $M(\omega)$ be a node. Consider $(a_0 = \text{root}, a_1, \dots, a_{h(a)} = a)$ the path from the root to a ; we associate with a a trajectory of (killed) random walk $\xi_a = (\xi_a(j))_{j \in \llbracket 0, h(a) \rrbracket}$ defined by

$$\xi_a(j) = \sum_{i=0}^j y(a_i), \text{ for } j \in \llbracket 0, h(a) \rrbracket.$$

The construction of $M(\omega)$ ensures that ξ_a is a simple random walk (independent increments with distribution ± 1 with probability $1/2$). We call branching random walk the multiset of the union of the trajectories ξ_a :

$$\Gamma = \{\xi_a, a \in \omega\}.$$

This multiset Γ can be ordered by using the underlying depth first order on ω . With a suitable normalization, Γ converges weakly to the Brownian snake with lifetime process the NBE (see Marckert & Mokkadem [13], Chassaing & Schaeffer [4], Gittenberger [8]). On $B(n)$, one defines the random variable W_n

$$W_n = \max_a \frac{\|\xi_a\|_\infty}{n^{1/4}}.$$

Using the results of the three papers cited above, one has

$$W_n \xrightarrow[n]{(d)} 2^{3/4}W. \tag{16}$$

Another object of interest is a measure on the multiset Ξ_n of terminal points of the branching random walk: $x(a) = \xi_a(h(a))$. Set

$$\Xi_n = \{x(a), a \in M(\omega)\}.$$

The random measure J_n is defined by

$$J_n = \frac{1}{2n+1} \sum_{x(a) \in \Xi_n} \delta\left(\frac{x(a)}{2^{1/4}n^{1/4}}\right).$$

Aldous [2] shows that the random measure J_n converges weakly in distribution to a random measure named ISE, the integrated super Brownian excursion,

$$J_n \xrightarrow[n]{(d)} \mu_{ISE}. \quad (17)$$

ISE is also the occupation measure on \mathbb{R} of the head of the Brownian snake with lifetime the NBE (see [13] and the papers of Le Gall & coauthors [6, 11, 10] for all informations on superprocesses).

Let us underline that the proofs of the convergence to the Brownian snake and the one of the convergence of the random measure (among others the proofs of (16) and (17)) use the fact that the values are identically distributed and independent for non brothers. In the next subsection, we prove convergences analogous to (16) and (17) for a tree model that does not satisfy this property.

3.2 Relationship between R_n , L_n and ISE

Let us build up a second probability space of marked trees: pick a tree ω at random in T_B^n . Now, for the values of the nodes z_i we set: if w' is the right brother of w then $(y(w), y(w')) = (+1, -1)$. This time, let us denote by $B^*(n)$ this set of marked trees. It is clear that, given ω , the marked tree say $M^*(\omega)$ is determined. Hence $B^*(n)$ and T_B^n are isomorphic probability spaces. On $B^*(n)$, the random variable W_n^* , and the random measure J_n^* are defined by

$$W_n^* = \max_a \frac{\|\xi_a\|_\infty}{n^{1/4}} = \frac{\max \Xi_n^*}{n^{1/4}}, \quad J_n^* = \frac{1}{2n+1} \sum_{x(a) \in \Xi_n^*} \delta\left(\frac{x(a)}{2^{1/4}n^{1/4}}\right),$$

where Ξ_n^* is the multiset of terminal points on $B^*(n)$. The displacement distribution does not allow to use the result of the preceding section (since -1 and $+1$ are not identically distributed!). In the present case, the convergence of the ordered multiset of trajectories Γ^* to the Brownian snake is not a consequence of [4] or [13] and besides, is not obvious. However, one has

Proposition 7 (a) *The real valued random variables W_n and W_n^* have the same distribution.*
(b) *The random measures J_n and J_n^* have the same distribution.*

Proof : Let us define a bijection in $B(n)$: the *transposition* around an internal node i , denoted by tra_i , is the map that exchanges the two marked subtrees of ω rooted in i . Two elements ω_1 and ω_2 of $B(n)$ are said to be in the same equivalence class iff there exists a finite sequence of internal nodes i_1, \dots, i_k such that

$$tra_{i_1}(tra_{i_2}(\dots(tra_{i_k}(\omega_1))\dots)) = \omega_2.$$

It is clear that, in each equivalence class there exists exactly one marked tree such that each left son is marked $+1$ and each right son is marked -1 (that is, a marked tree belonging to $B^*(n)$). Moreover, each class contains 2^n elements since, starting from an element of $B^*(n)$, one can construct 2^n different marked trees from $B(n)$ using transpositions. Proposition 7 holds since W_n and J_n are invariant by transpositions. \square

3.3 Proof of Theorems 5 and 6

Proof of Theorem 5 : If $x(v) = \xi_v(h(v))$ is the displacement of the node v , one has $x(v) = l(v) - r(v)$. The random measure J_n^* can be expressed in terms of the right and left processes:

$$J_n^* = \frac{1}{2n+1} \sum_{k=0}^{2n} \delta\left(\frac{L_n(\frac{k}{2n}) - R_n(\frac{k}{2n})}{2^{1/4}n^{1/4}}\right). \quad (18)$$

Moreover,

$$\frac{\max \Xi_n^*}{n^{1/4}} = \frac{\|L_n - R_n\|_\infty}{n^{1/4}} = W_n^*.$$

Theorem 5 then follows from the combination of (16), Proposition 7 and (17). \square

Proof of Theorem 6 :

Proof of (14) : For any t , one has

$$\mathcal{H}_n(t) = L_n^I(t) + 1.$$

Hence,

$$2\mathcal{H}_n(t) - H_n^I(t) = L_n^I(t) - R_n^I(t) + 2.$$

Hence (14) is a consequence of (13) since in the marked trees of $B^*(n)$ each node is either an internal node or at distance 1 of an internal node. \square

Proof of (15) : Thanks to Proposition 7 and formula (17), J_n^* converges weakly to ISE. Let M be the set of Borel probability measures on \mathbb{R} . A metric on M is given by the bounded Lipschitz metric (see [16]); denote by F the set of 1-Lipschitz functions on \mathbb{R}^+ bounded by 1. For μ and ν in M , we note

$$\|\nu - \mu\|_{BL} = \sup_{f \in F} \left| \int f d\nu - \int f d\mu \right|.$$

The weak convergence for the BL metric implies the usual one, namely if $(\nu_n)_n$ is a sequence of measure in M such that $\|\nu_n - \nu\|_{BL} \rightarrow 0$ then ν_n converges weakly to ν .

The left-hand side of (15) can be rewritten as

$$K_n^* = \frac{1}{n} \sum_{a \text{ internal node}} \delta\left(\frac{x(a) + 2}{2^{1/4}n^{1/4}}\right).$$

To prove (15), it suffices to show that $\|K_n^* - J_n^*\|_{BL} \rightarrow 0$. Let a be a given node (different from the root) in ω . The node a is the child of its father say b . Hence,

$$x(a) = x(b) \pm 1.$$

Then

$$J_n^* = \frac{1}{2n+1} \delta_0 + \frac{1}{2n+1} \sum_{v \text{ internal node}} \delta\left(\frac{x(v) + 1}{(2n)^{1/4}}\right) + \delta\left(\frac{x(v) - 1}{(2n)^{1/4}}\right).$$

Take f in F , then

$$\left| \int f dJ_n^* - \int f dK_n^* \right| = \left| \frac{f(0)}{2n+1} + \sum_{v \text{ internal node}} \frac{f\left(\frac{x(v)+1}{(2n)^{1/4}}\right)}{2n+1} + \frac{f\left(\frac{x(v)-1}{(2n)^{1/4}}\right)}{2n+1} - \frac{2f\left(\frac{x(v)+2}{(2n)^{1/4}}\right)}{2n} \right|. \quad (19)$$

Writing

$$\frac{2f\left(\frac{x(v)+2}{(2n)^{1/4}}\right)}{2n} = \frac{2f\left(\frac{x(v)+2}{(2n)^{1/4}}\right)}{2n+1} + \frac{2f\left(\frac{x(v)+2}{(2n)^{1/4}}\right)}{4n^2+2n},$$

and using the Lipschitz condition on f , we obtain that the right-hand side of (19) is smaller than

$$\left|\frac{f(0)}{2n+1}\right| + \left|\sum_{v \text{ internal node}} \frac{1}{2n+1} \frac{(1+3)}{(2n)^{1/4}}\right| + \sum_{v \text{ internal node}} \left|\frac{2f\left(\frac{x(v)}{(2n)^{1/4}}\right)}{4n^2+2n}\right| = O(n^{-1})\|f\|_{\infty} + O(n^{-1/4});$$

this goes to 0 when n goes to $+\infty$. \square

Acknowledgements

I would like to thank the two referees for their careful readings and for numerous advices and comments.

References

- [1] D. Aldous, (1991) *The continuum random tree. II: An overview.*, Stochastic analysis, Proc. Symp., Durham/UK 1990, Lond. Math. Soc. Lect. Note Ser. 167, 23-70 .
- [2] D. Aldous, (1993) *Tree-Based Models for Random Distribution of Mass.*, J. Statist. Phys. 73 625-641.
- [3] C. Borgs, J. Chayes, R. van der Hofstad, G. Slade, (1999) *Mean-field lattice trees.*, Ann. Comb. 3, No.2-4, 205-221.
- [4] P. Chassaing, G. Schaeffer, (2002) *Random Planar Lattices and Integrated SuperBrownian Excursion.*, manuscript.
- [5] T. Cox, R. Durrett, E.A. Perkins, (1999) *Rescaled particle systems converging to super-Brownian motion.*, Bramson, Maury (ed.) et al., Perplexing problems in probability. Festschrift in honor of Harry Kesten. Prog. Probab. 44, 269-284.
- [6] T. Duquesne, J.F. Le Gall, (2002) *Random trees, Lévy Processes and spatial branching processes.*, Astérisque. 281. Paris: Société Mathématique de France.
- [7] P. Flajolet, R. Sedgewick, (1996) *An Introduction to the Analysis of Algorithms* Addison-Wesley.
- [8] B. Gittenberger (2002) *A note on “State spaces of the snake and its tour – Convergence of the discrete snake” by J.-F. Marckert and A. Mokkadem* Submitted.
- [9] T.E. Harris (1952). *First passage and recurrence distributions*, Trans. Amer. Math. Soc. 73, 471-486.

- [10] J.F. Le Gall, (1999) *Spatial branching processes, random snakes and partial differential equations.*, Lectures in Mathematics, Birkhäuser.
- [11] J.F. Le Gall, Y. Le Jan, (1998) *Branching processes in Levy processes: The exploration process.*, Ann. Probab. 26, No.1, 213-252.
- [12] J.F. Marckert, A. Molkadem, (2001) *The depth first processes of Galton-Watson trees converge to the same Brownian excursion.*, Annals of Probab., Vol. 31, No. 3 - July 2003.
- [13] J.F. Marckert, A. Molkadem, (2002) *States spaces of the snake and of its tour – Convergence of the discrete snake*, to appear in J. of Theo. Prob..
- [14] J.F. Marckert, A. Molkadem, (2002) *Ladder variables, Internal structure of Galton-Watson trees and Finite branching random walks*, Journal of Applied Probab. 40.3, sep. 2003.
- [15] G. Slade, (1999) *Lattice trees, percolation and super-Brownian motion.*, Bramson, Maury (ed.) et al., Perplexing problems in probability. Festschrift in honor of Harry Kesten. Prog. Probab. 44, 35-51.
- [16] A. van der Vaart, J.A. Wellner, (1996) *Weak convergence and empirical processes. With applications to statistics.*, Springer Series in Statistics.