

COMPUTATIONAL NEUROSCIENCE

from single neuron to behavior

NICOLAS.ROUGIER@INRIA.FR

INRIA - UNIVERSITY OF BORDEAUX - INSTITUTE OF NEURODEGENERATIVE DISEASES



The biological neuron

A typical neuron consists of a cell body, dendrites, and an axon.

A neuron is an electrically excitable cell that processes and transmits information through electrical and chemical signals.

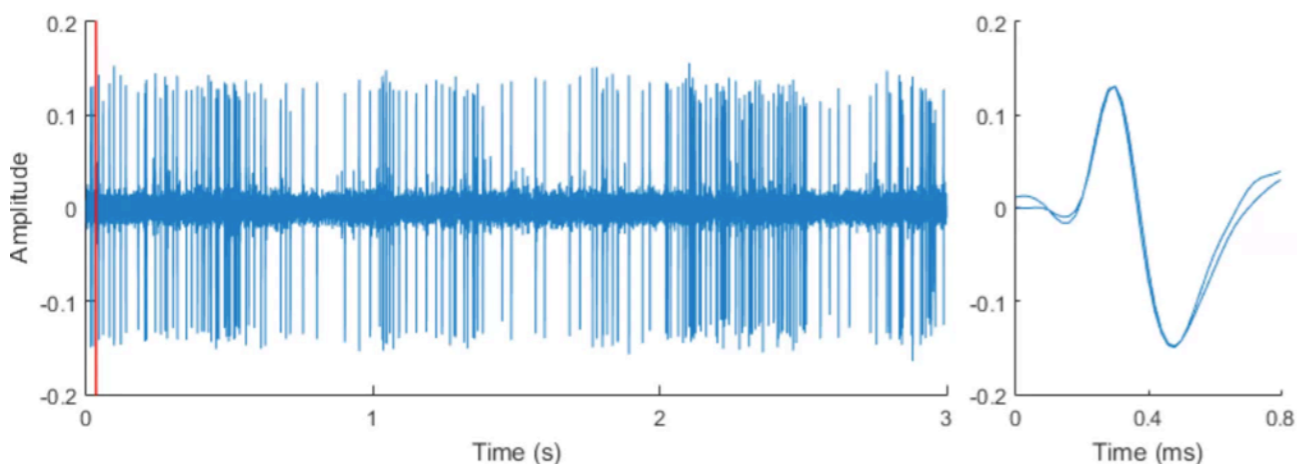
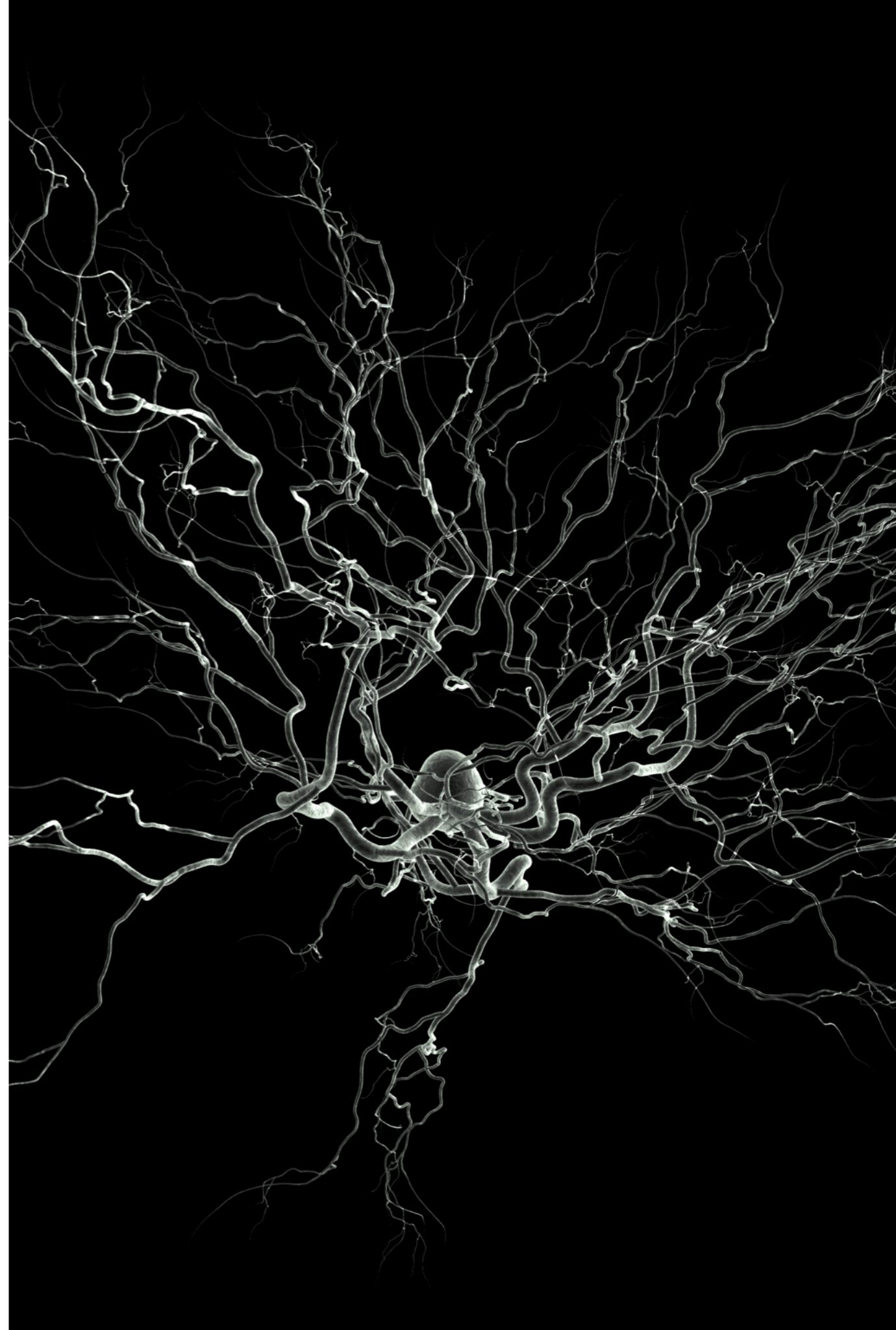

Neural circuits

Neurons never function in isolation; they are organized into ensembles or circuits that process specific kinds of information.

Afferent neurons, efferent neurons and interneurons are the basic constituents of all neural circuits.

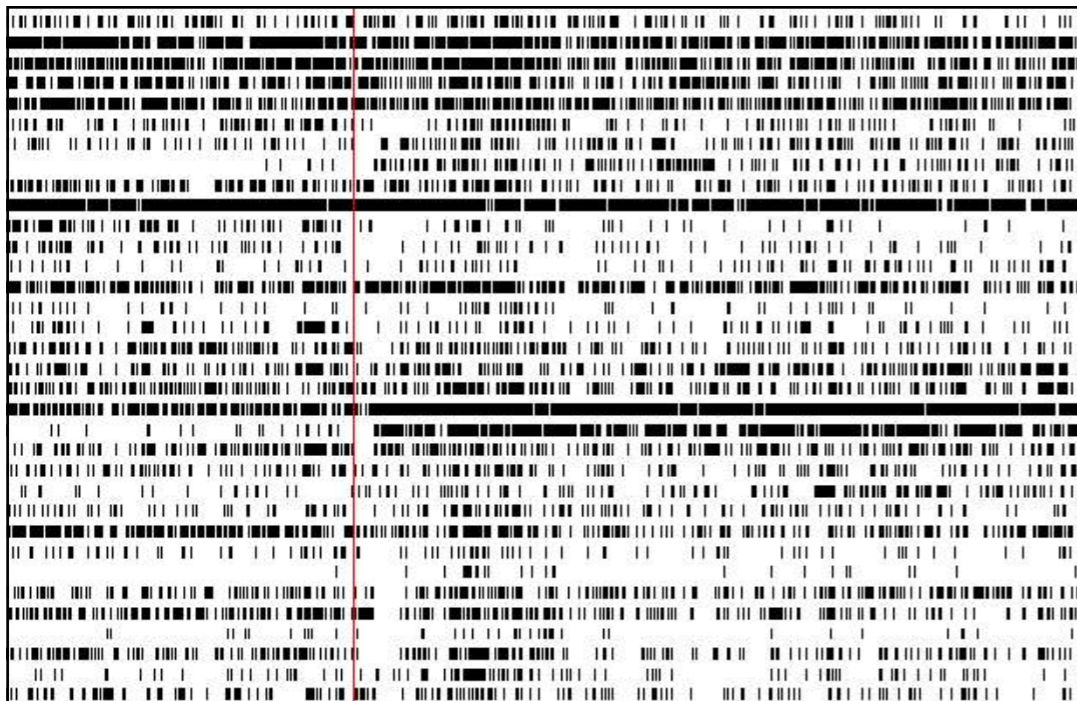

Brain, body & behavior

The human brain is made of
 ≈ 86 billions neurons

Each neuron is connected to
 $\approx 10,000$ other neurons (average)

1mm^3 of cortex contains ≈ 1 billion
connections

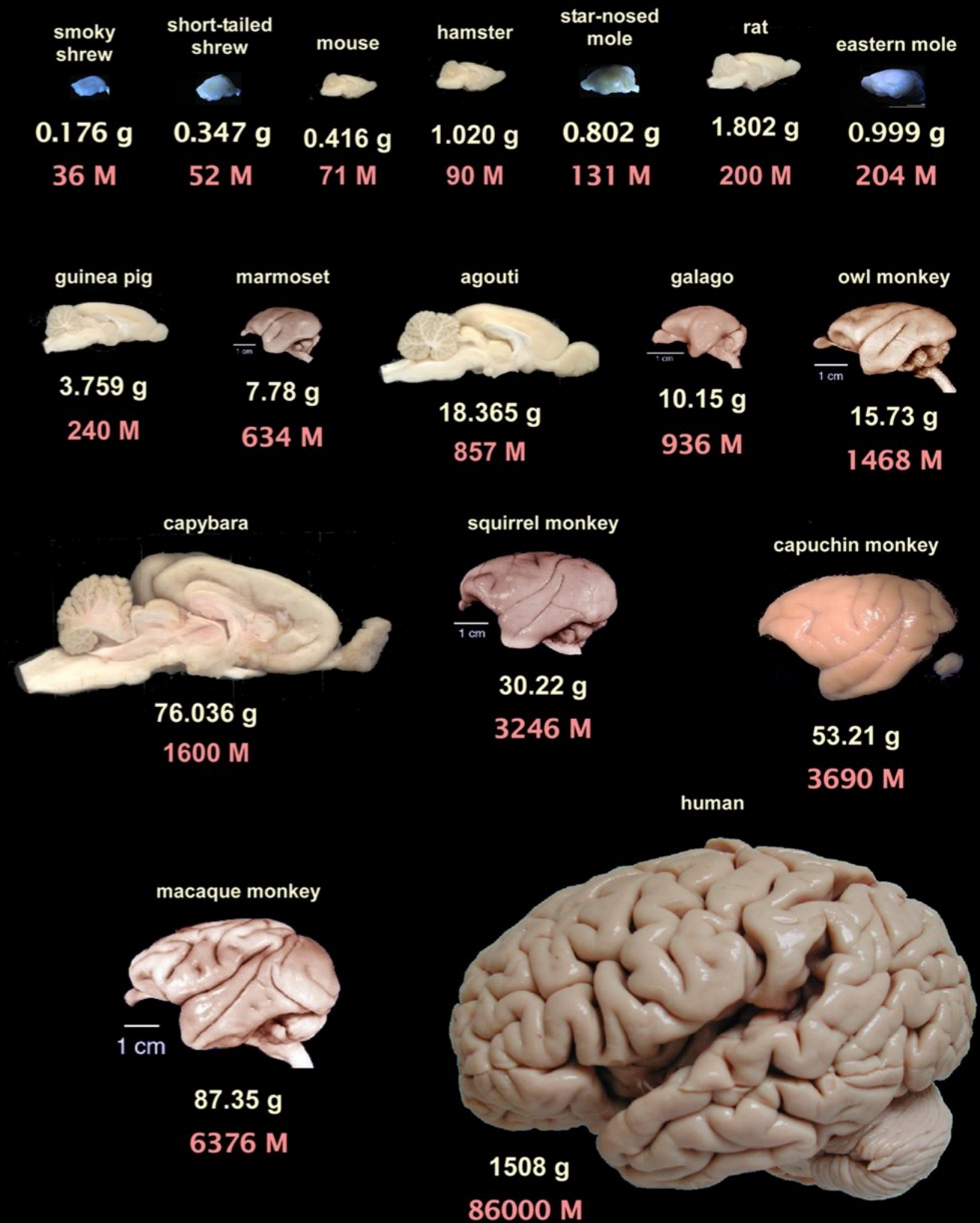

To model the brain

To emulate → new algorithms
(e.g. deep learning)

To heal → new therapies
(e.g. deep brain stimulation)

To understand → new knowledge
(e.g. visual attention)

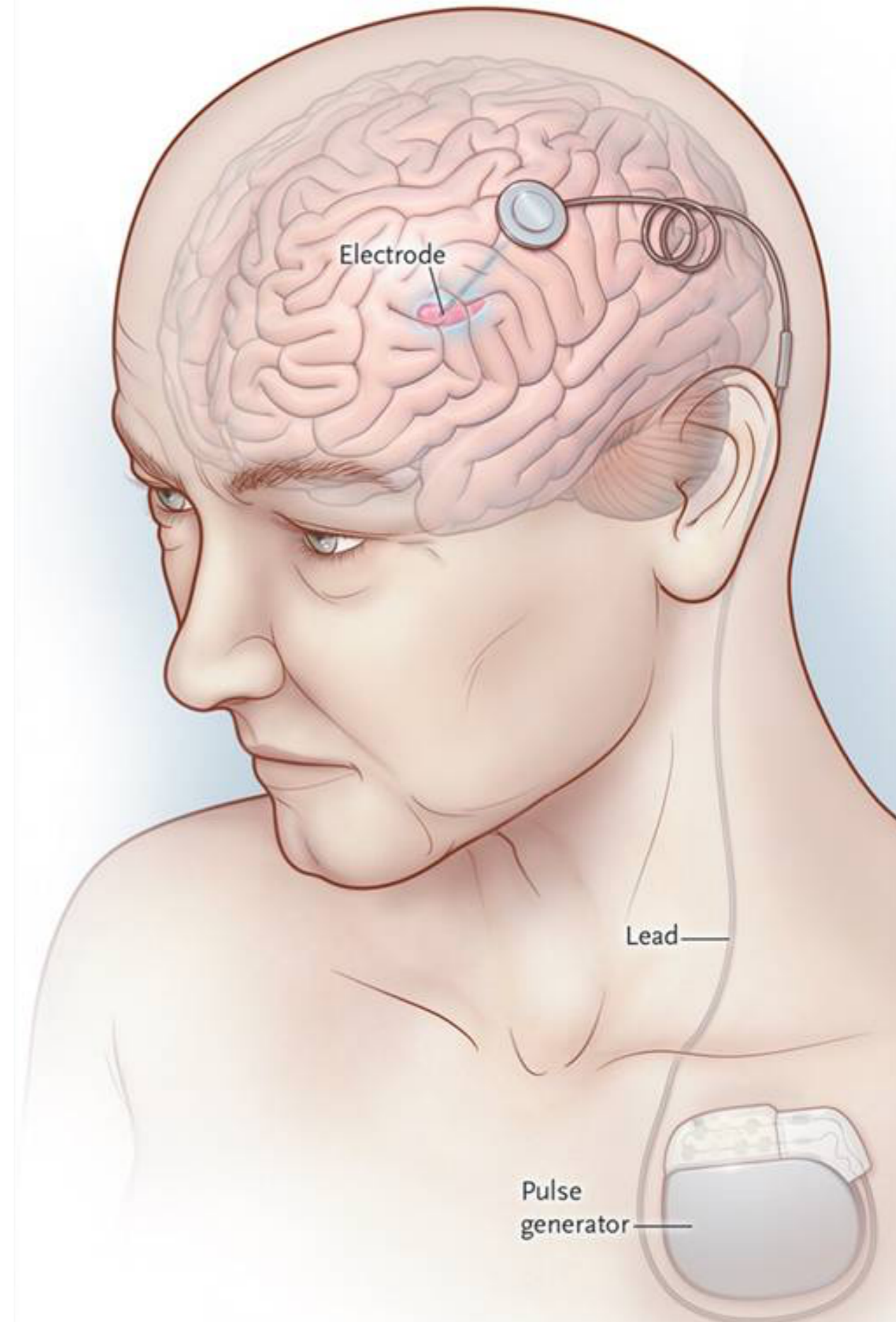

What kind of models?

Connectionist models for performances & learning

Biophysical models for simulation & prediction

Cognitive models for the emulation of behavior

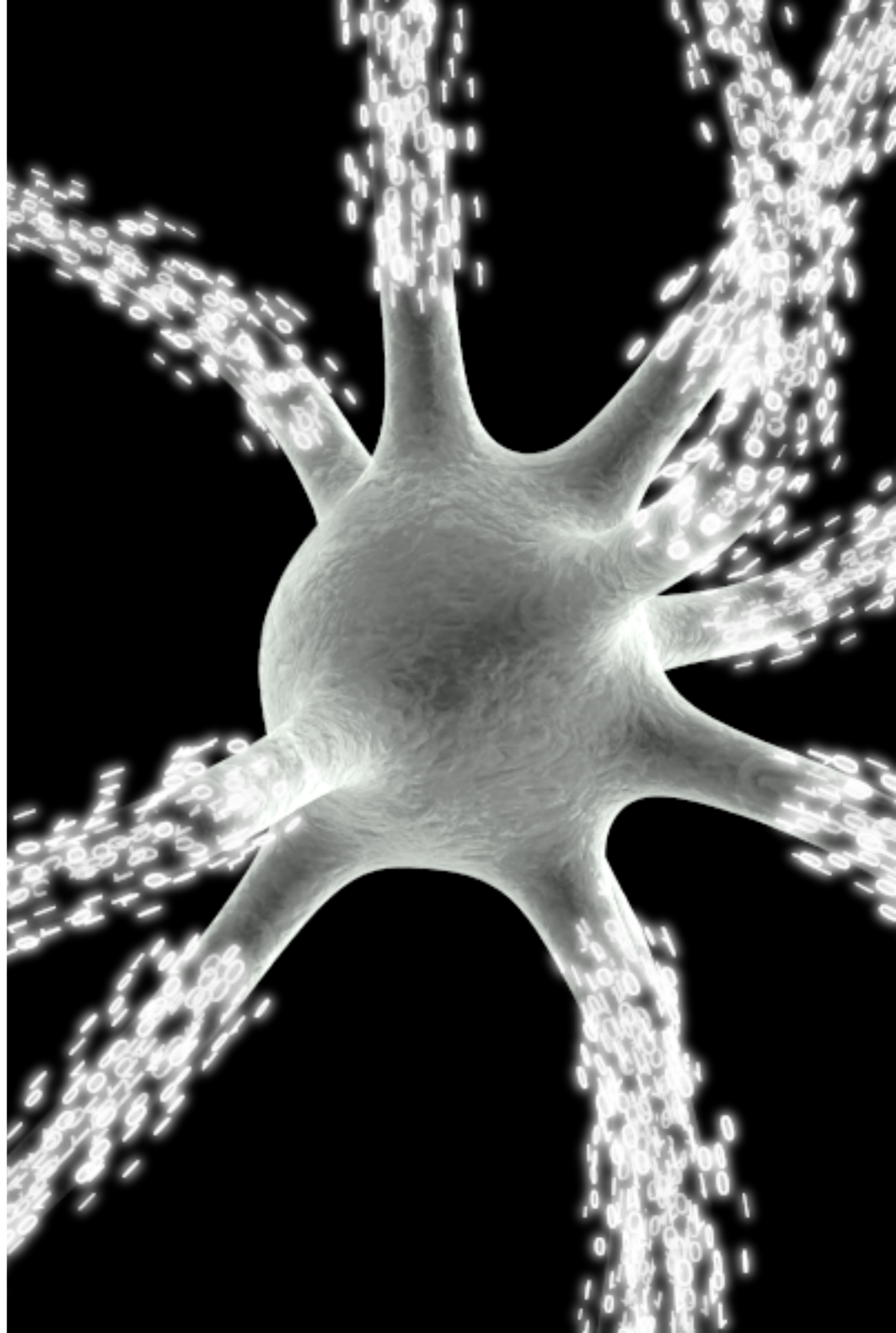

How to build models?

Basic material

- Anatomy and physiology
- Experiments & recordings
- Pathologies & lesions

Working hypotheses

- Extreme simplifications
- Parallel & distributed computing
- Dynamic systems & learning

Validation

- Predictions
- Explanations



Single neuron

Disclaimer

Reminder : Essentially, all models are wrong but some are useful.

(George E.P. Box, 1987)

Artificial neuron are over-simplified models of the biological reality, but some of them can give a fair account of actual behavior.

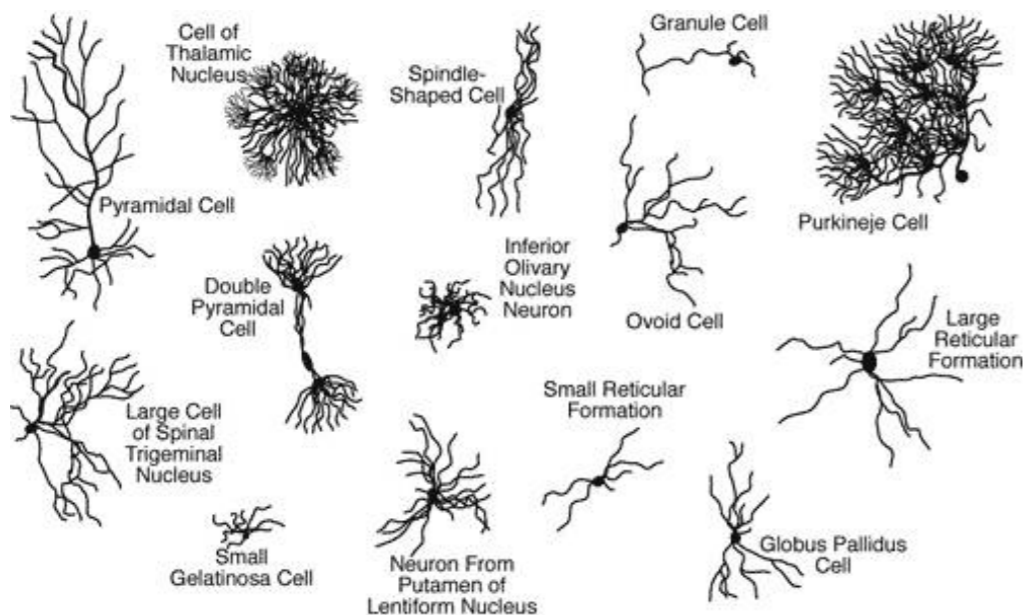
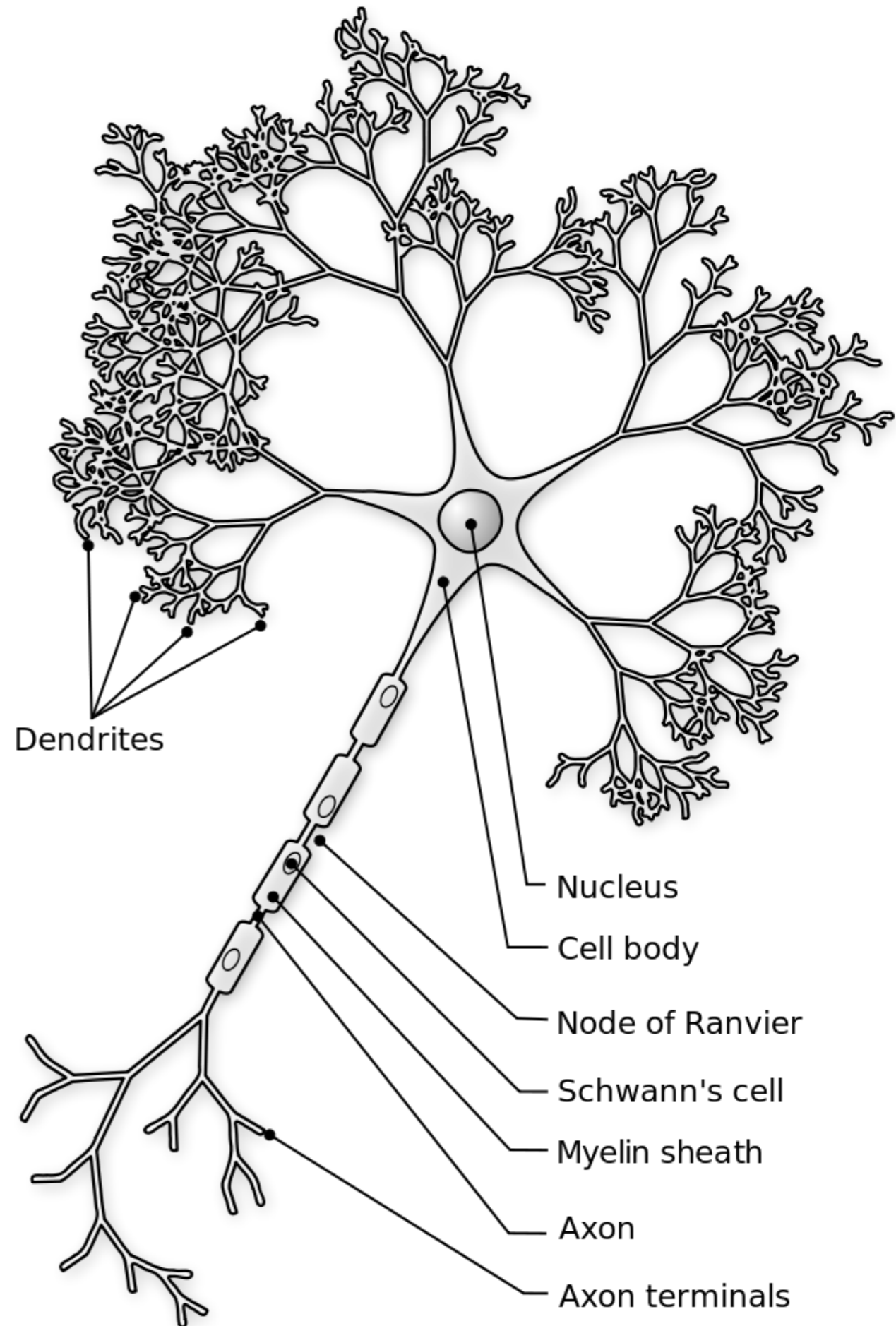

The frog sciatic nerve

From frogs to integrate-and-fire
Nicolas Brunel · Mark C. W. van Rossum
Biological Cybernetics (2007)

“Lapicque used a more exotic one, namely, a ballistic rheotome. This is a gun-like contraption that first shoots a bullet through a first wire, making the contact, and a bit later the same bullet cuts a second wire in its path, breaking the contact.”



LOUIS LAPICQUE

1866-1952

The formal neuron

The McCulloch-Pitts model (1943) is an extremely simple artificial neuron. The inputs could be either a zero or a one as well as the output.

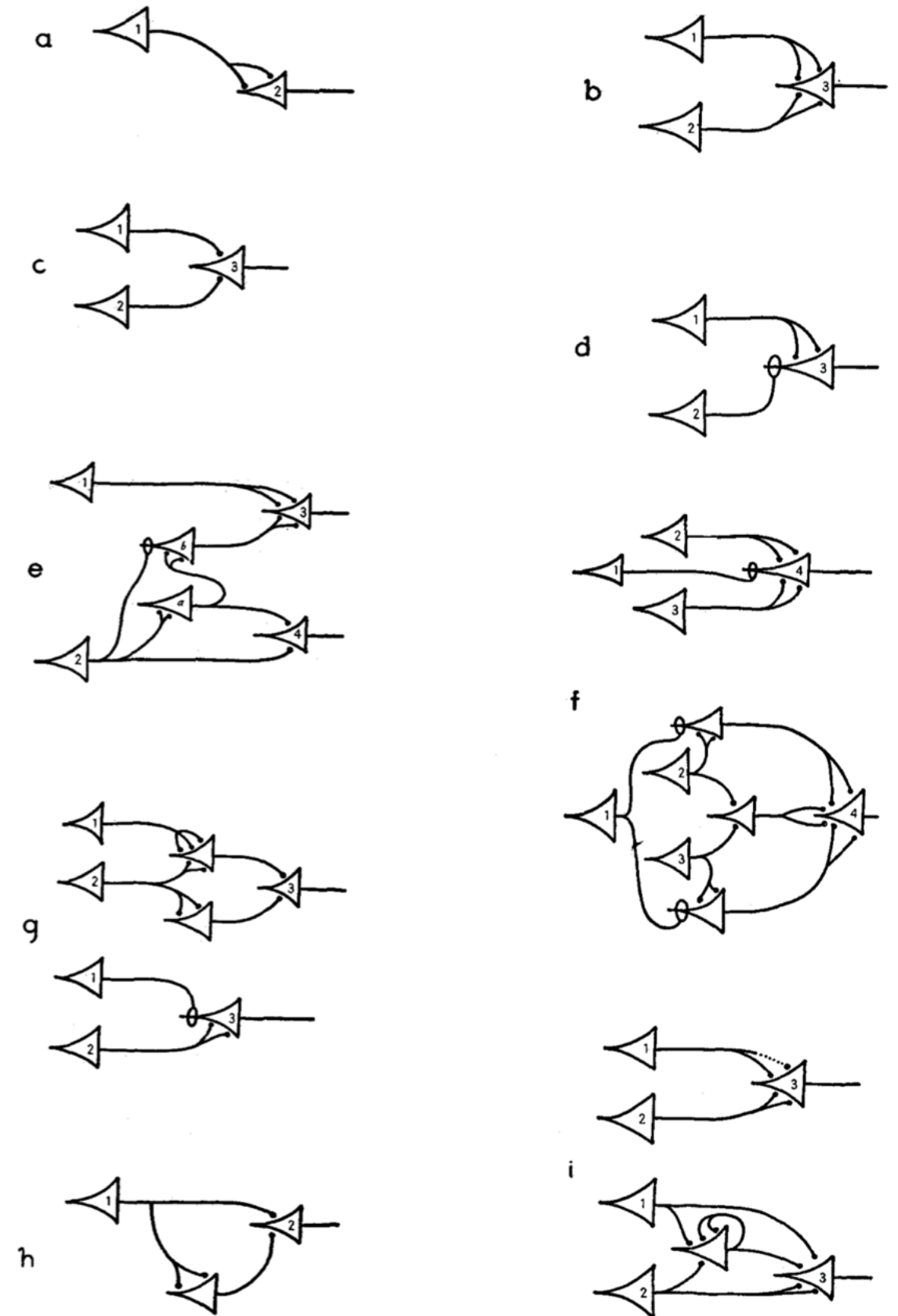
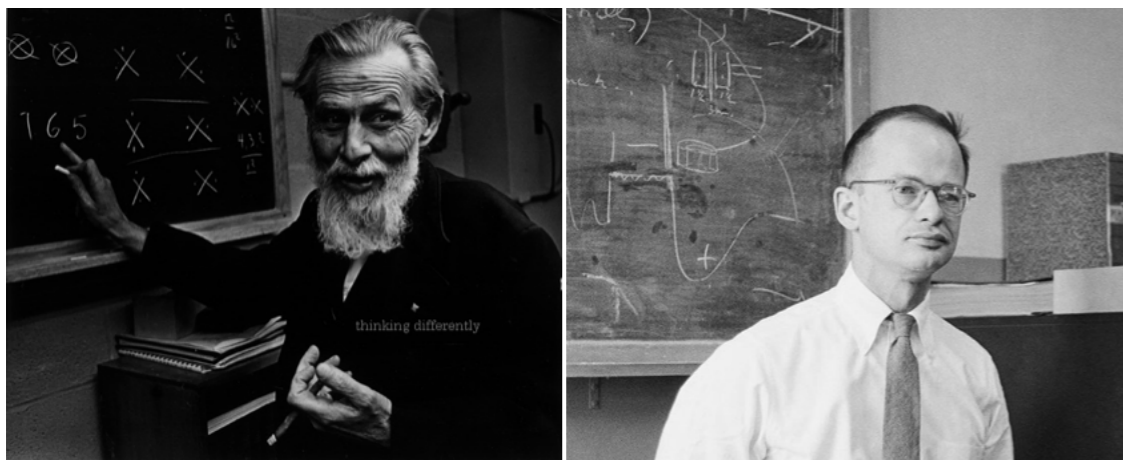
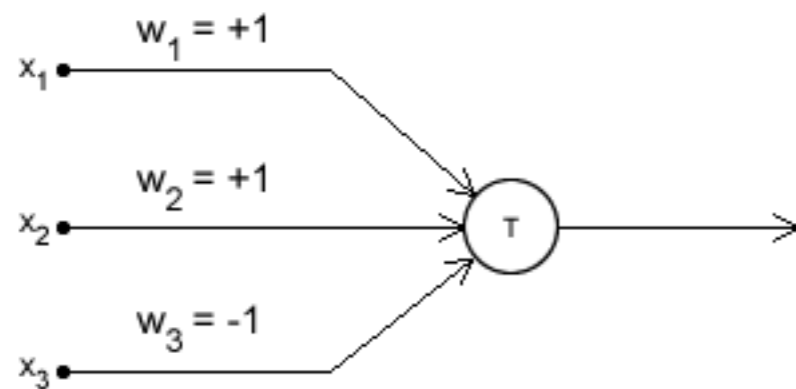
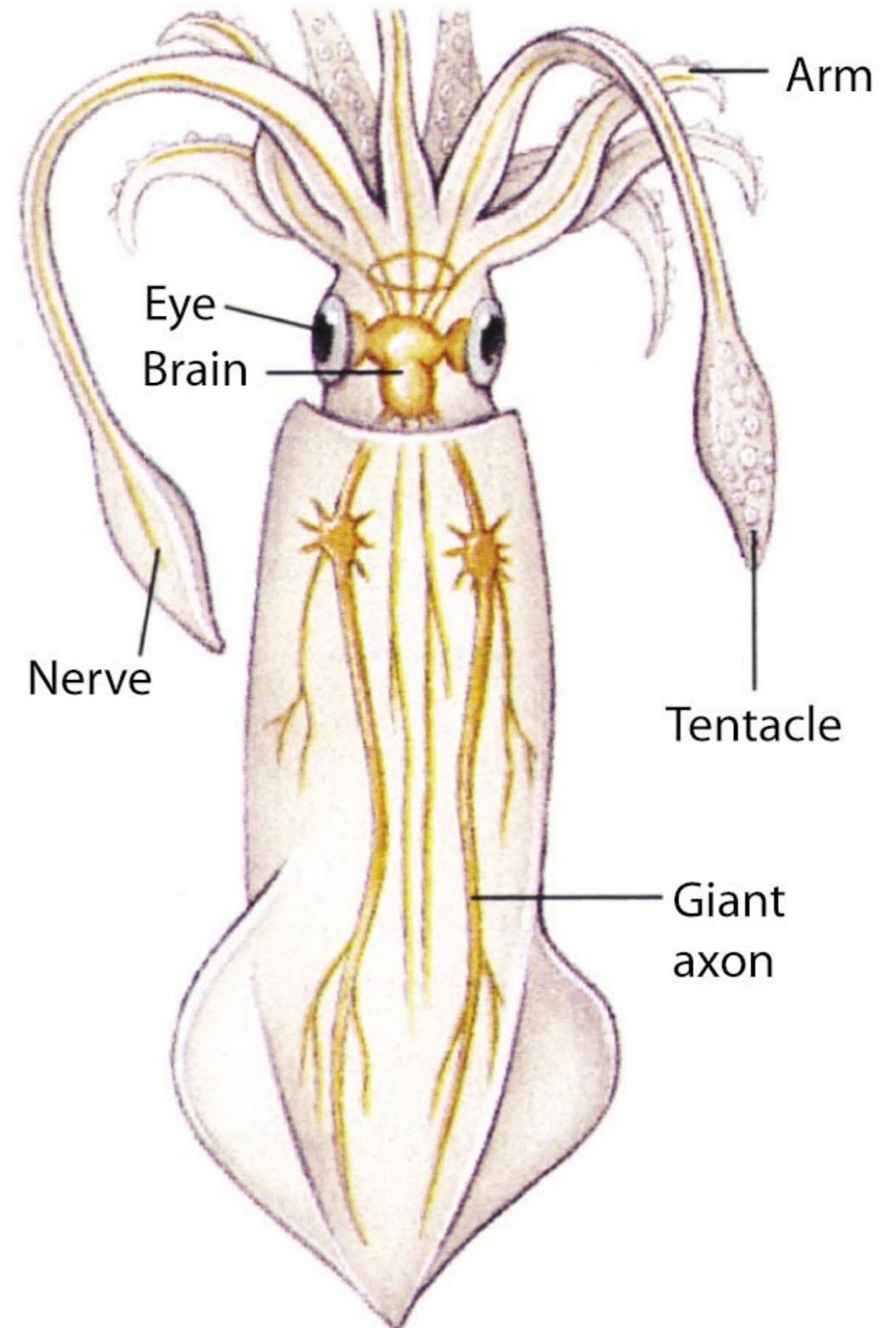
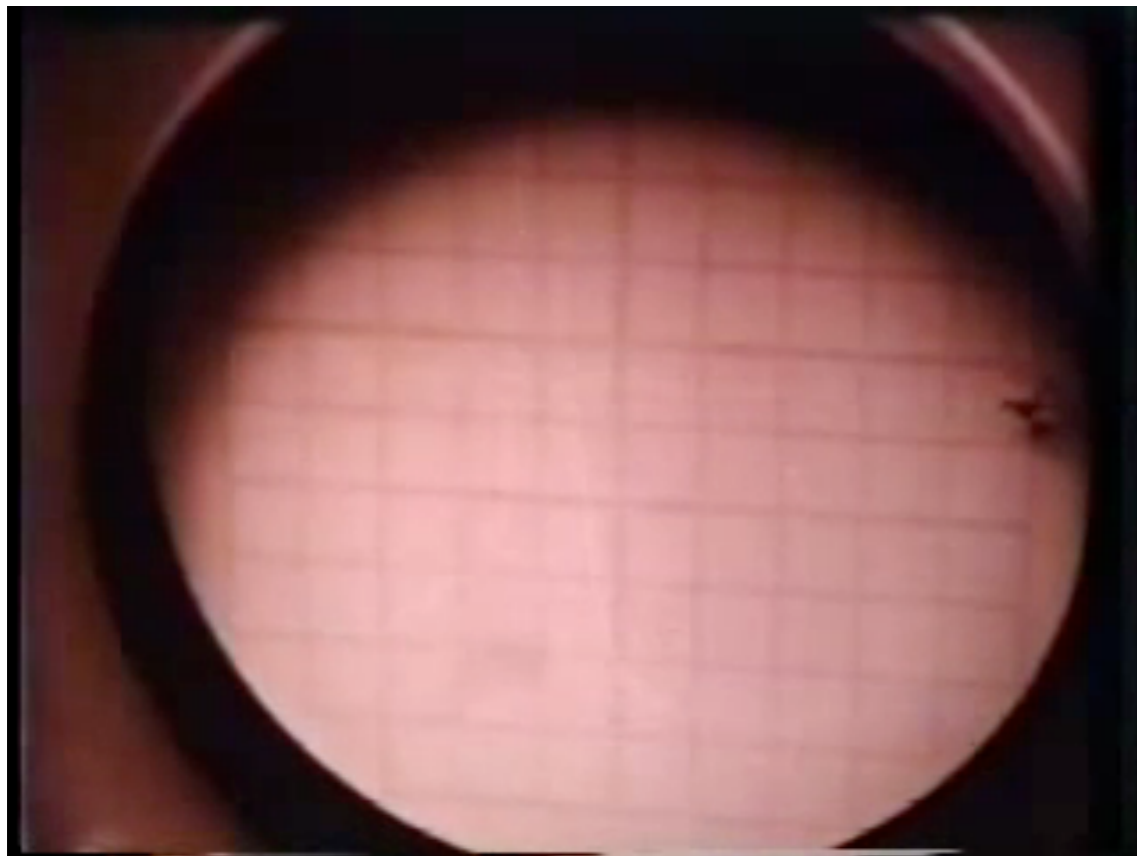

FIGURE 1

The squid giant axon

In 1952, Alan Lloyd Hodgkin and Andrew Huxley described the ionic mechanisms underlying the initiation and propagation of action potentials in the squid giant axon.



Anatomy of a spike

An action potential (spike) is a short-lasting event in which the electrical membrane potential of a cell rapidly rises and falls, following a consistent trajectory.

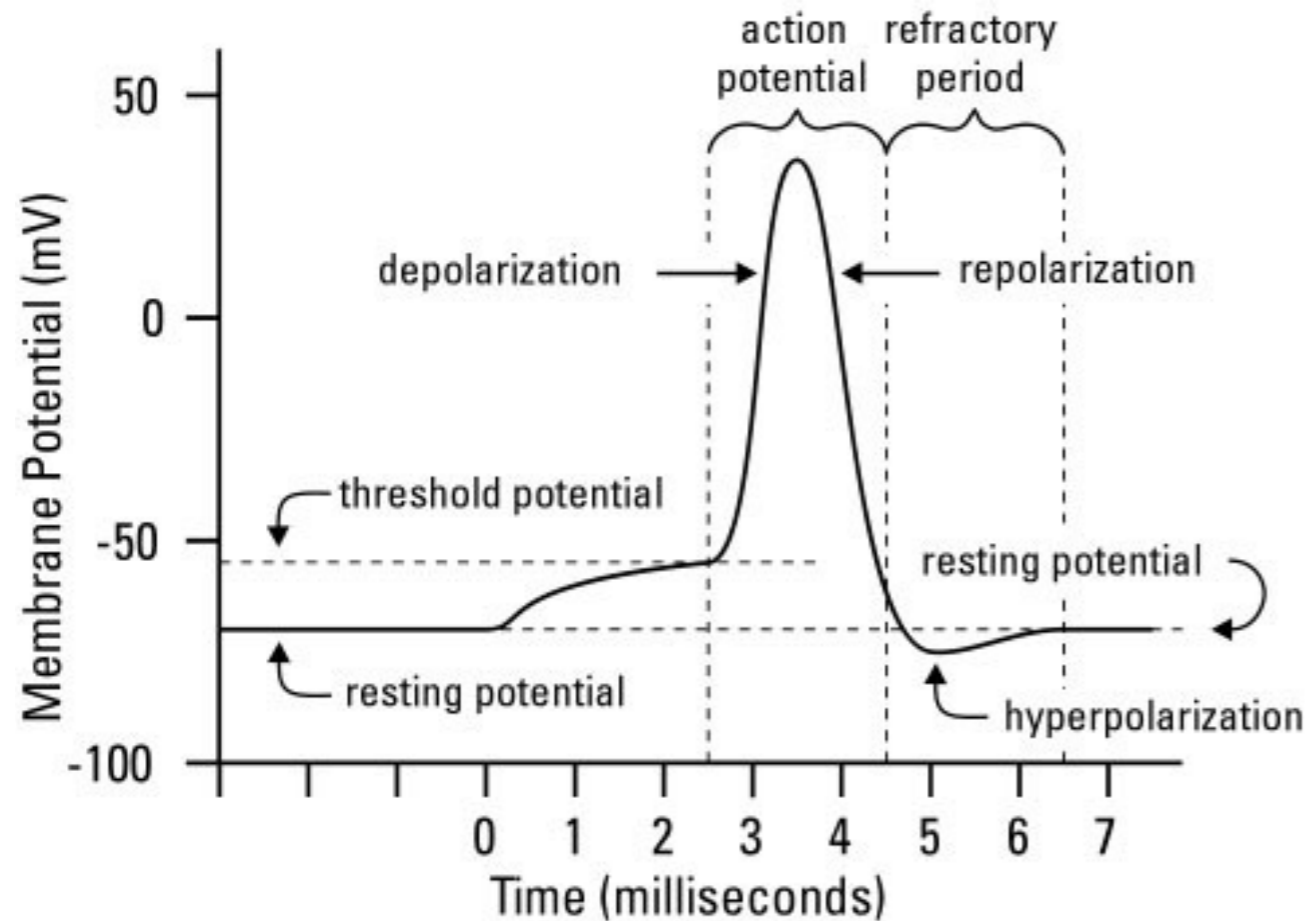

(a) Resting potential

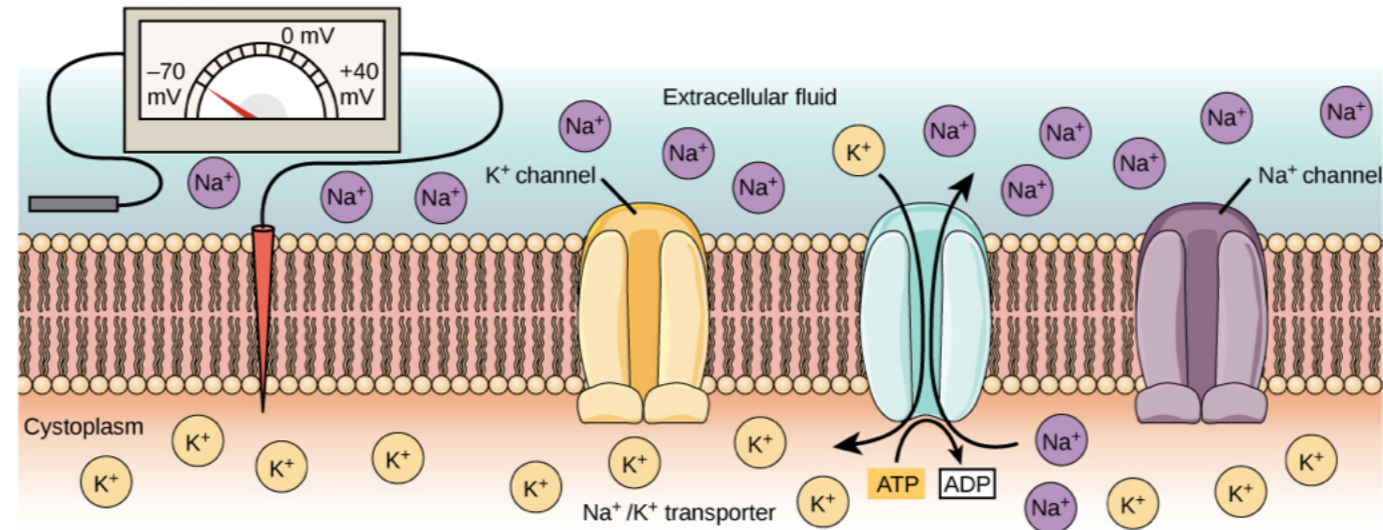

At the resting potential, all voltage-gated Na⁺ channels and most voltage-gated K⁺ channels are closed. The Na⁺/K⁺ transporter pumps K⁺ ions into the cell and Na⁺ ions out.

(b) Depolarization

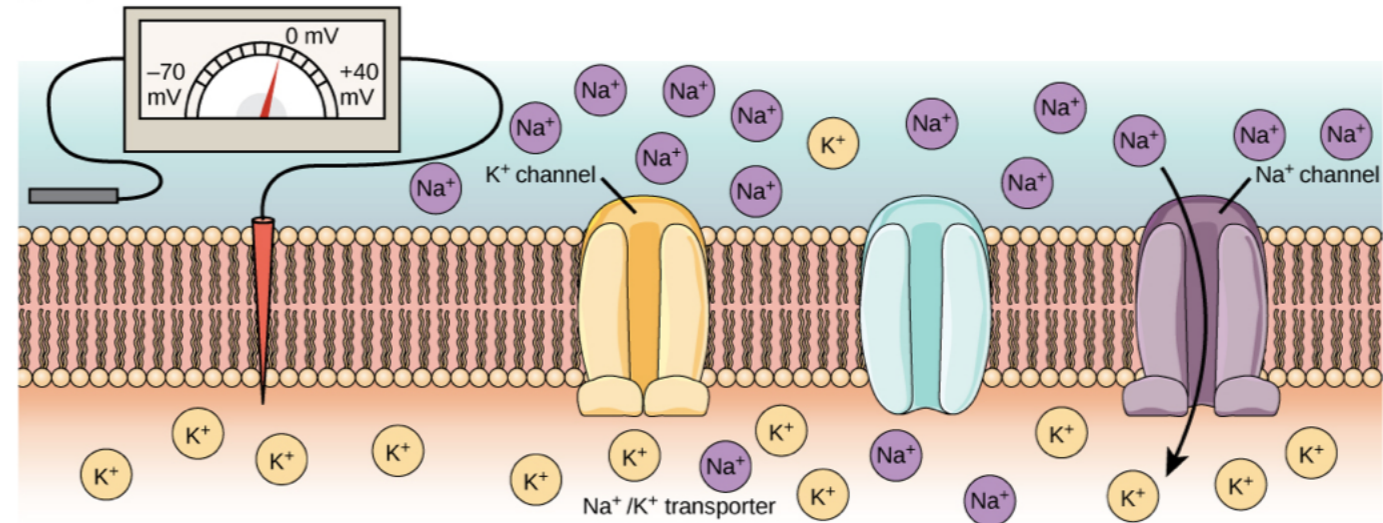

In response to a depolarization, some Na⁺ channels open, allowing Na⁺ ions to enter the cell. The membrane starts to depolarize (the charge across the membrane lessens). If the threshold of excitation is reached, all the Na⁺ channels open.

(c) Hyperpolarization

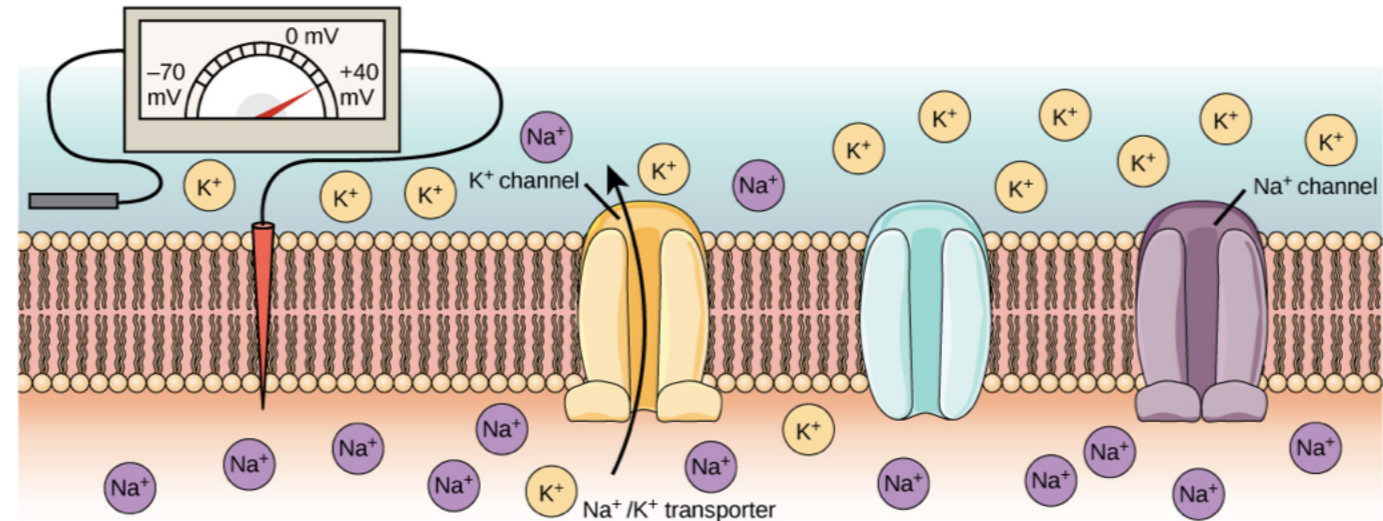

At the peak action potential, Na⁺ channels close while K⁺ channels open. K⁺ leaves the cell, and the membrane eventually becomes hyperpolarized.

Voltage clamp

Based on a series of breakthrough voltage-clamp experiments, Hodgkin & Huxley developed a detailed mathematical model of the voltage-dependent and time-dependent properties of the Na⁺ and K⁺ conductances.

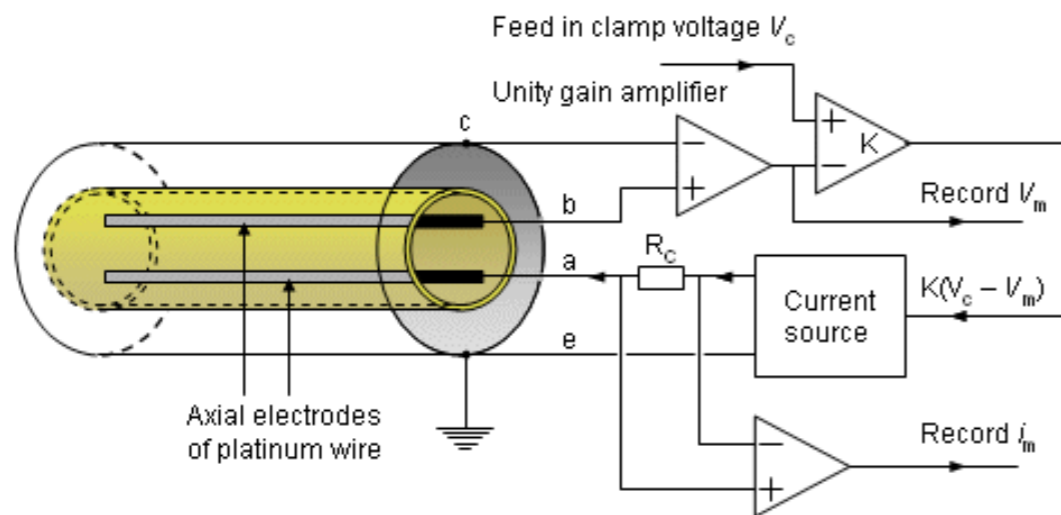
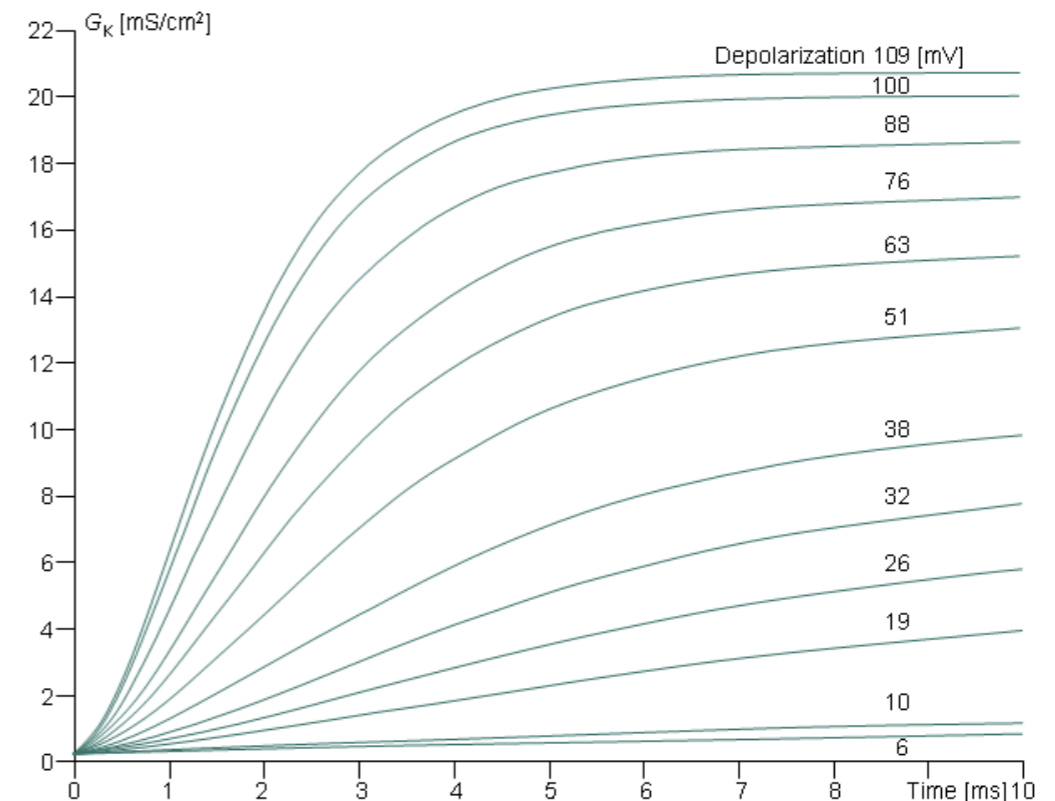
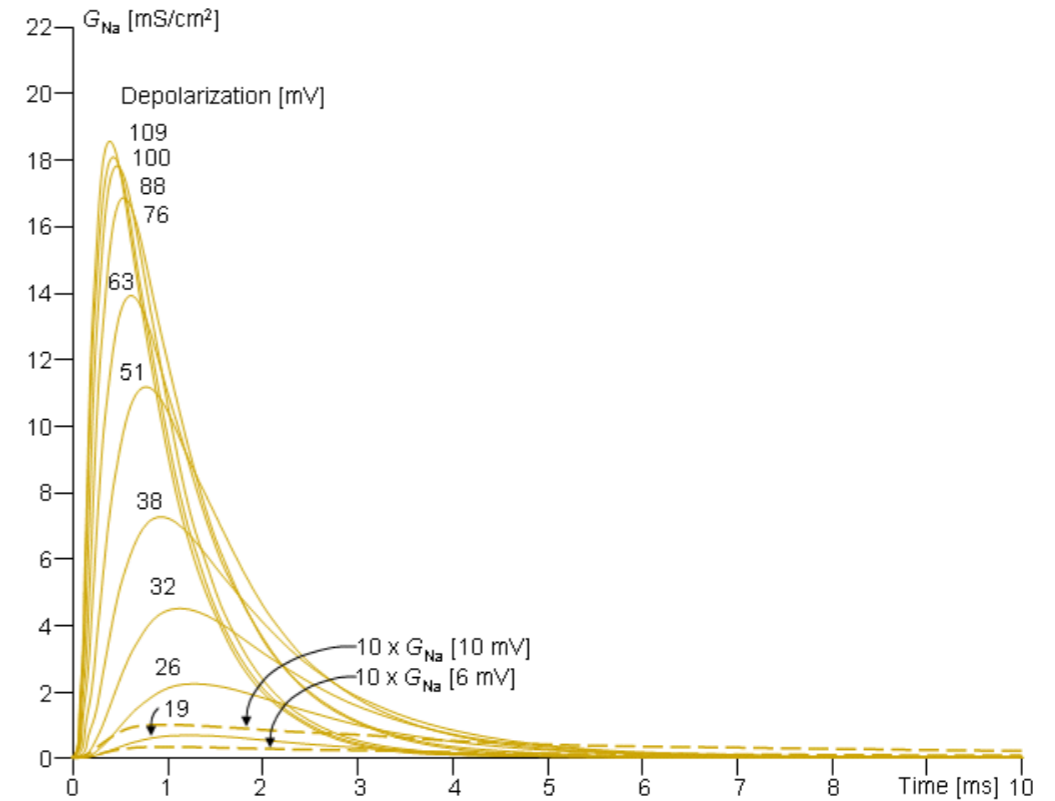

The Hodgkin & Huxley model (1952)

The empirical work lead to the development of a coupled set of differential equations describing the ionic basis of the action potential.

The ionic current is subdivided into three distinct components, a sodium current I_{Na} , a potassium current I_K , and a small leakage current I_L (chloride ions).

Based on the experiments, they were able to accurately estimate all parameters.

$$I = C_m \frac{dV_m}{dt} + \bar{g}_K n^4 (V_m - V_K) + \bar{g}_{Na} m^3 h (V_m - V_{Na}) + \bar{g}_l (V_m - V_l),$$

$$\frac{dn}{dt} = \alpha_n(V_m)(1 - n) - \beta_n(V_m)n$$

$$\frac{dm}{dt} = \alpha_m(V_m)(1 - m) - \beta_m(V_m)m$$

$$\frac{dh}{dt} = \alpha_h(V_m)(1 - h) - \beta_h(V_m)h$$

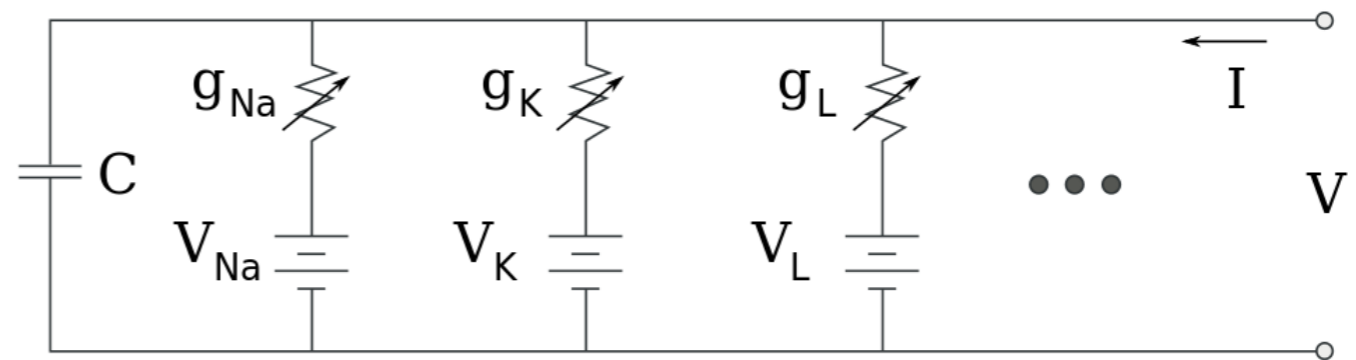

The Hodgkin & Huxley model (1952)

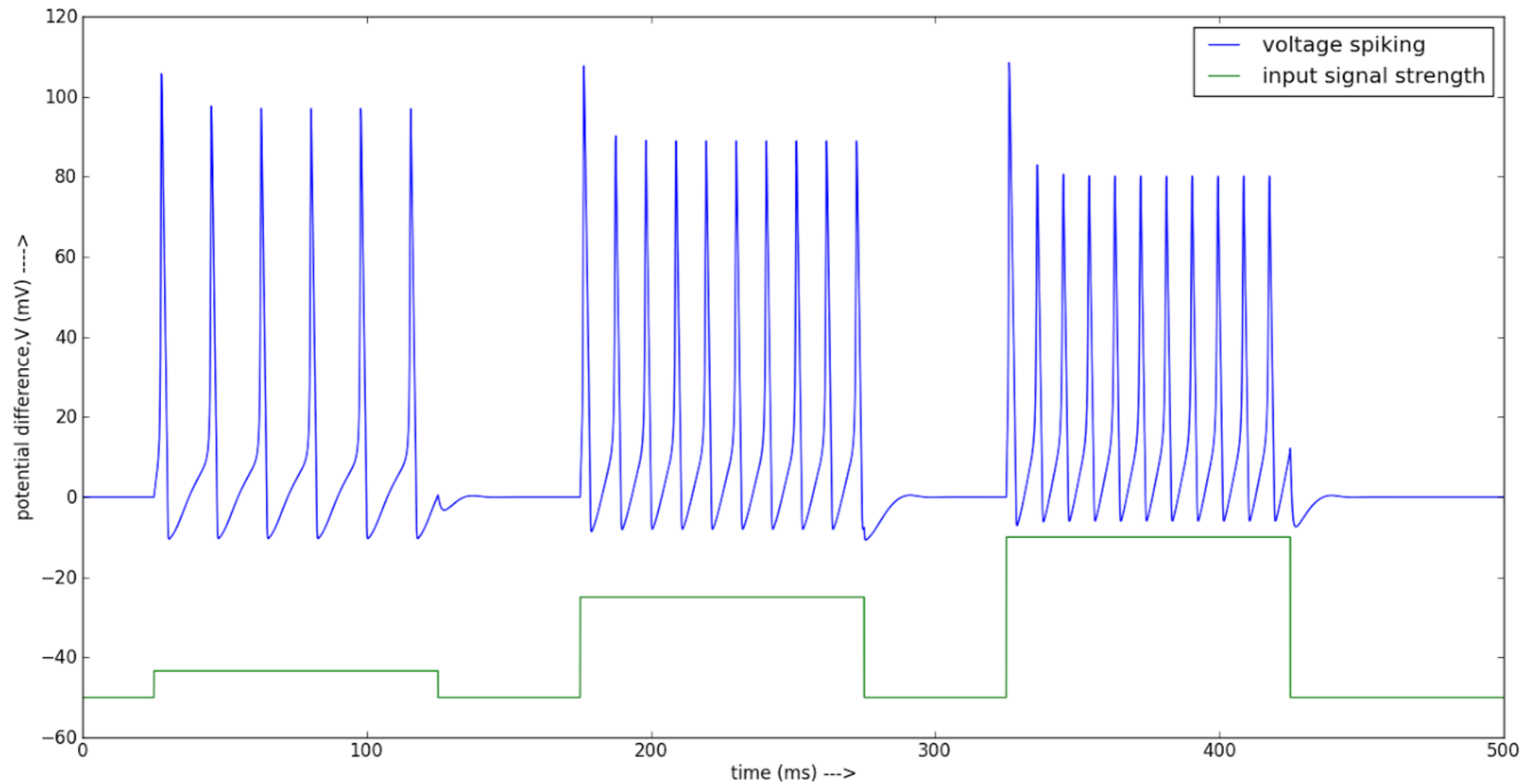

The Hodgkin & Huxley model (1952)

The Nobel prize was awarded to both men a decade later in 1963.

The field of computational neuroscience was launched.

More than 60 years later, the Hodgkin-Huxley model is still a reference.

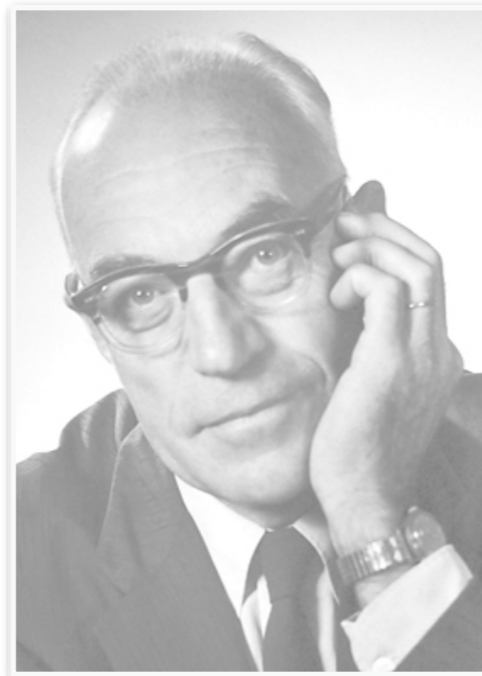

J.C. Eccles

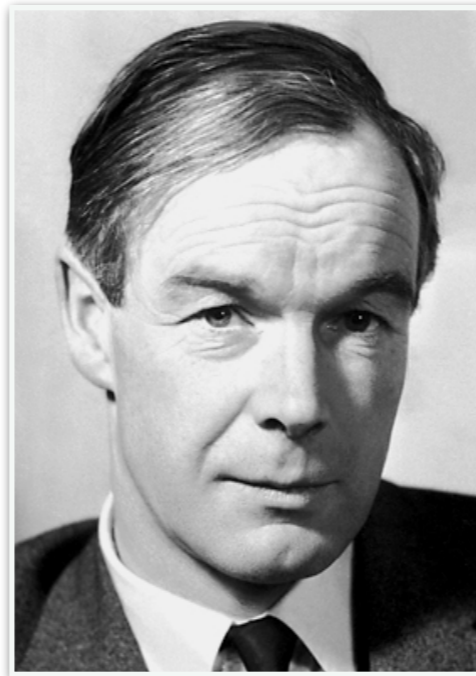

A.L. Hodgkin

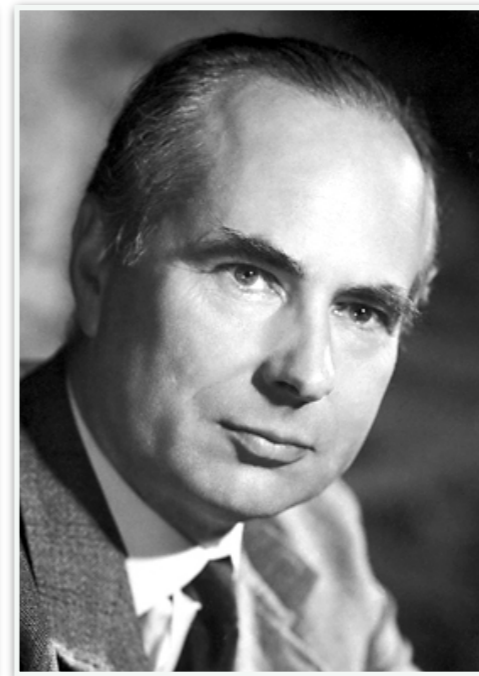

A. Huxley

Reduced models are simpler

The behavior of high-dimensional nonlinear differential equations is difficult to visualize and even more difficult to analyze.

The four-dimensional model of Hodgkin-Huxley can be reduced to two dimensions under the assumption that the m -dynamics is fast as compared to u , h , and n , and that the latter two evolve on the same time scale.

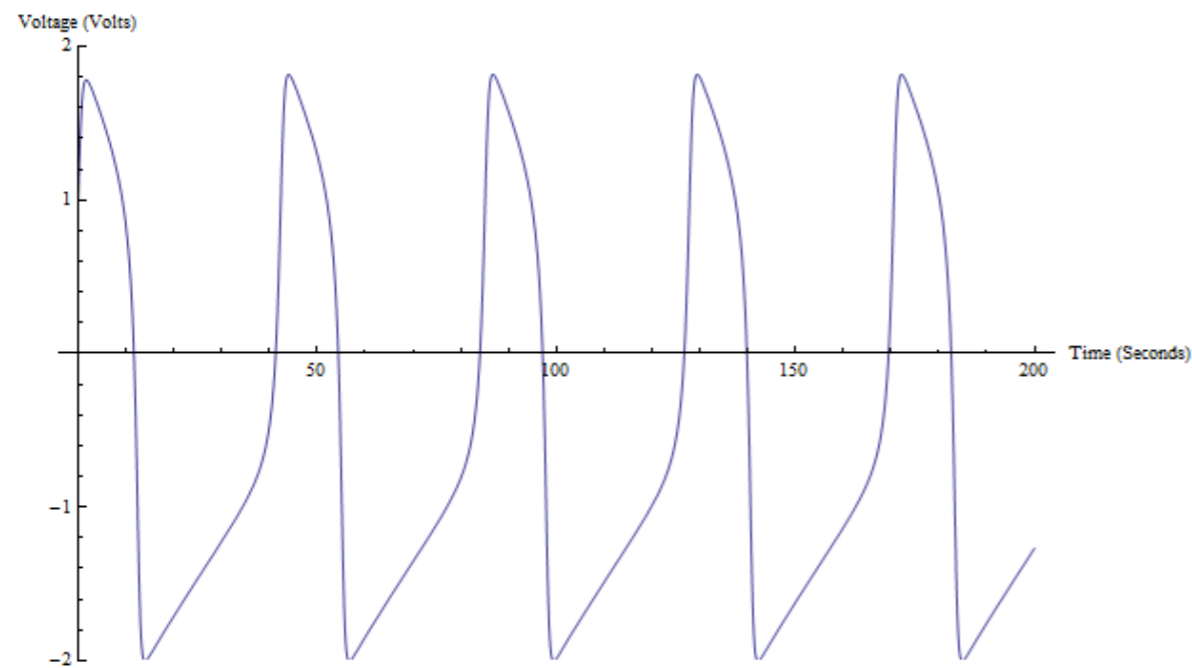

FitzHugh–Nagumo (1961)

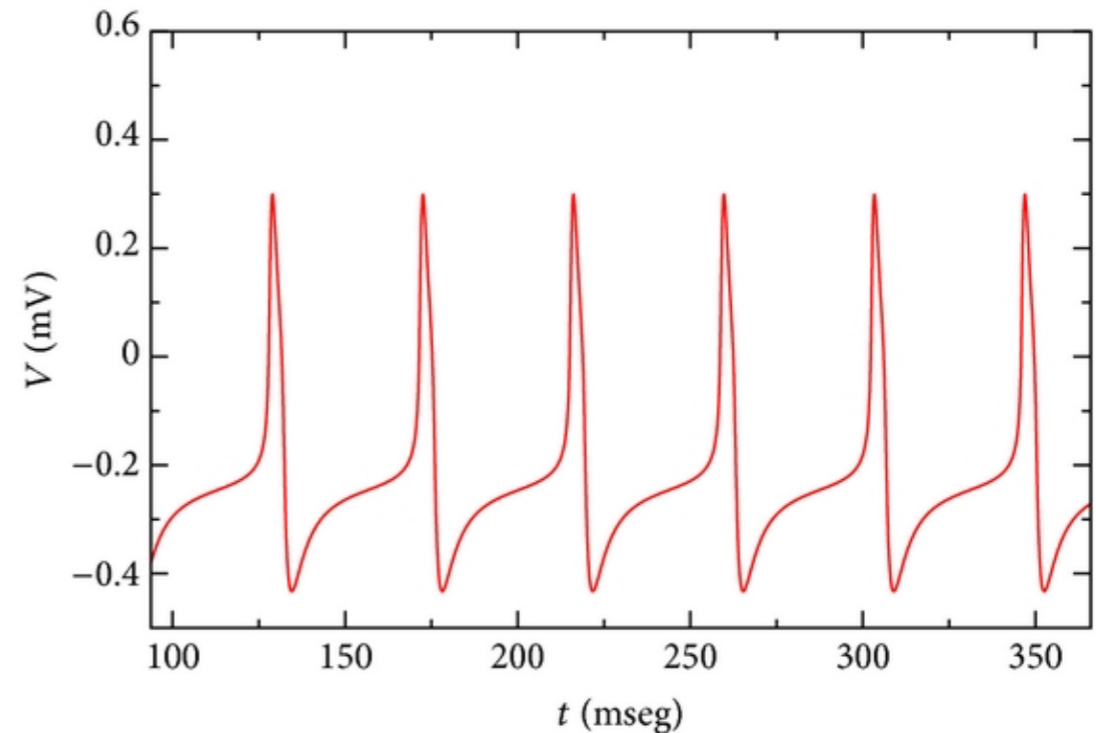

Morris Lescar (1981)

Formal neuron

Reduced models are still too complex...

Even if **conductance-based** models are the simplest possible biophysical representation of an excitable cell and can be reduced to simpler model, they remain difficult to analyse (and simulate) due to their intrinsic complexity.

For this reason, simple **threshold-based** models have been developed and are highly popular for studying neural coding, memory, and network dynamics.

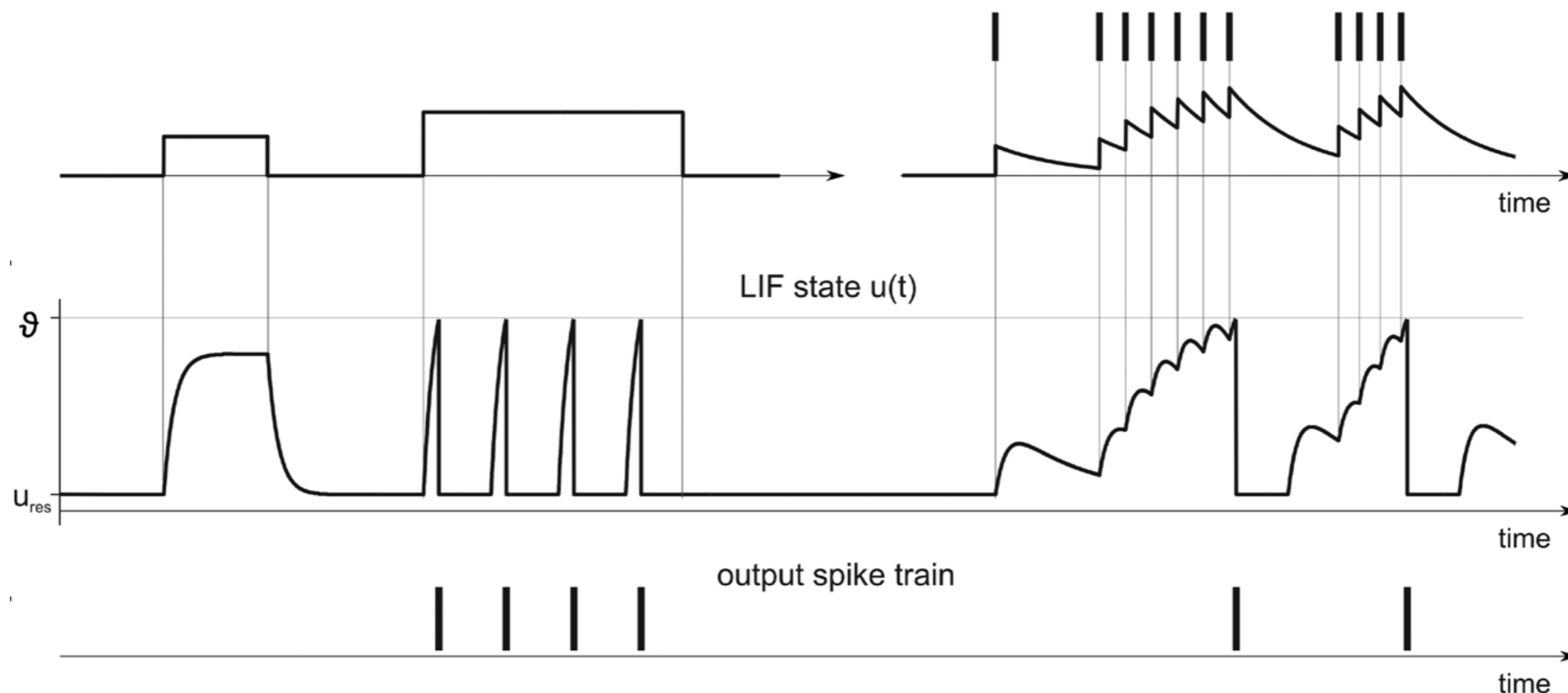

Leaky Integrate & Fire

In the leaky integrate and fire (LIF) model, spike occurs when the membrane potential crosses a given threshold, and is instantaneously reset to a given reset value. But no bursting mode (B), no adaptation (C), no inhibitory rebound (D)

$$\tau \frac{du(t)}{dt} = -[u(t) - u_{\text{rest}}] + R \cdot I(t)$$

if $u(t) > \vartheta$ then $\lim_{\delta \rightarrow 0, \delta > 0} u(t+\delta) = u_r$

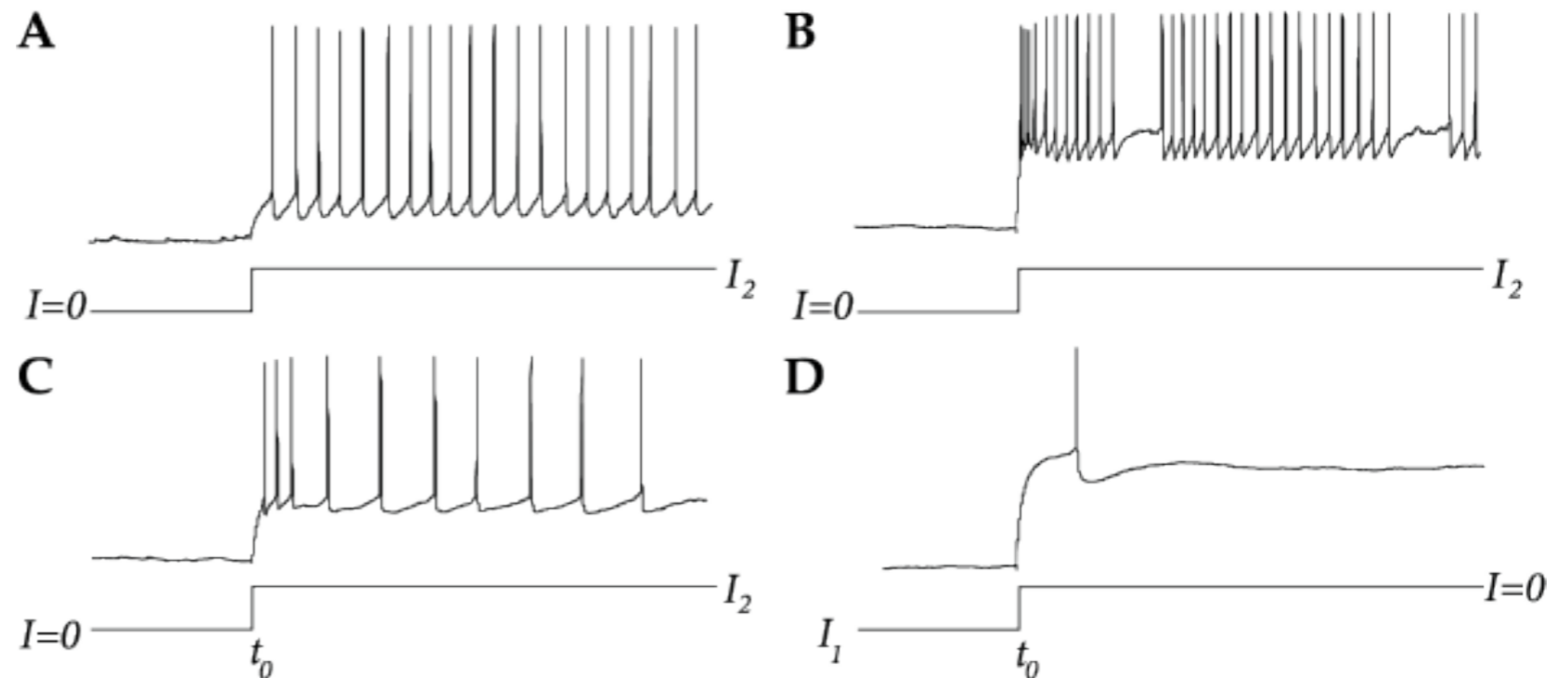
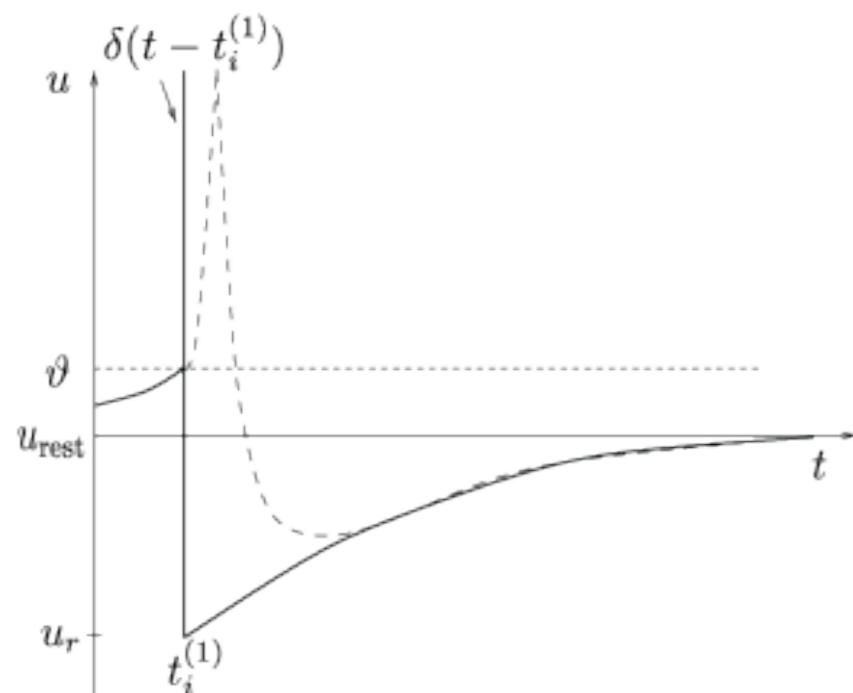

Izhikevich model

In 2003, E. Izhikevich introduced a model that reproduces spiking and bursting behavior of known types of cortical neurons. The model combines the biological plausibility of Hodgkin-Huxley-type dynamics and the computational efficiency of integrate-and-fire neurons.

$$\begin{aligned} dv/dt &= 0.04v^2 + 5v + 10 - u + I \\ du/dt &= a(bv - u) \\ \text{if } v=30\text{mV then } v &= c, \quad u = u + d \end{aligned}$$

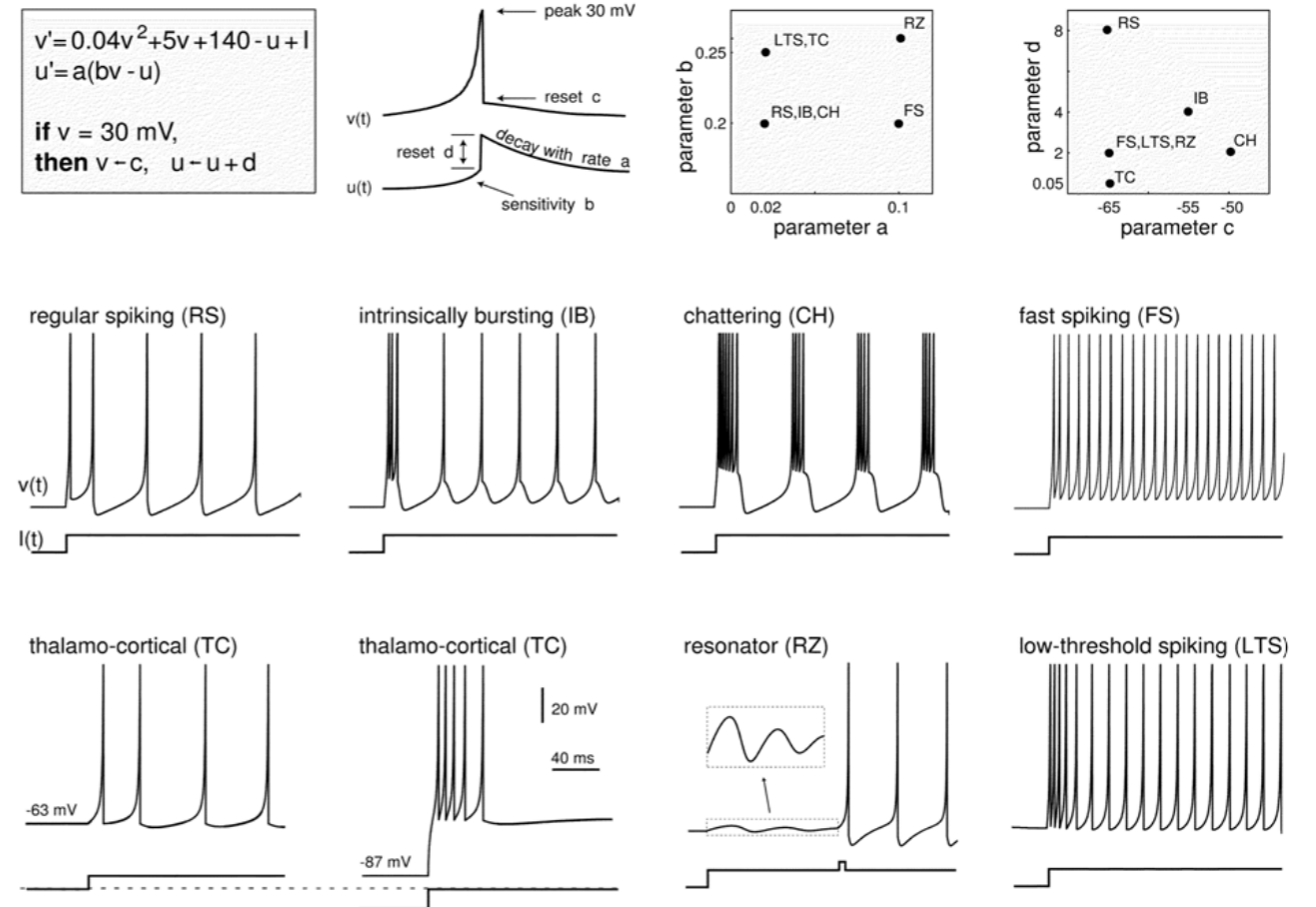

Which model for what purpose ?

It depends on what you're trying to achieve...

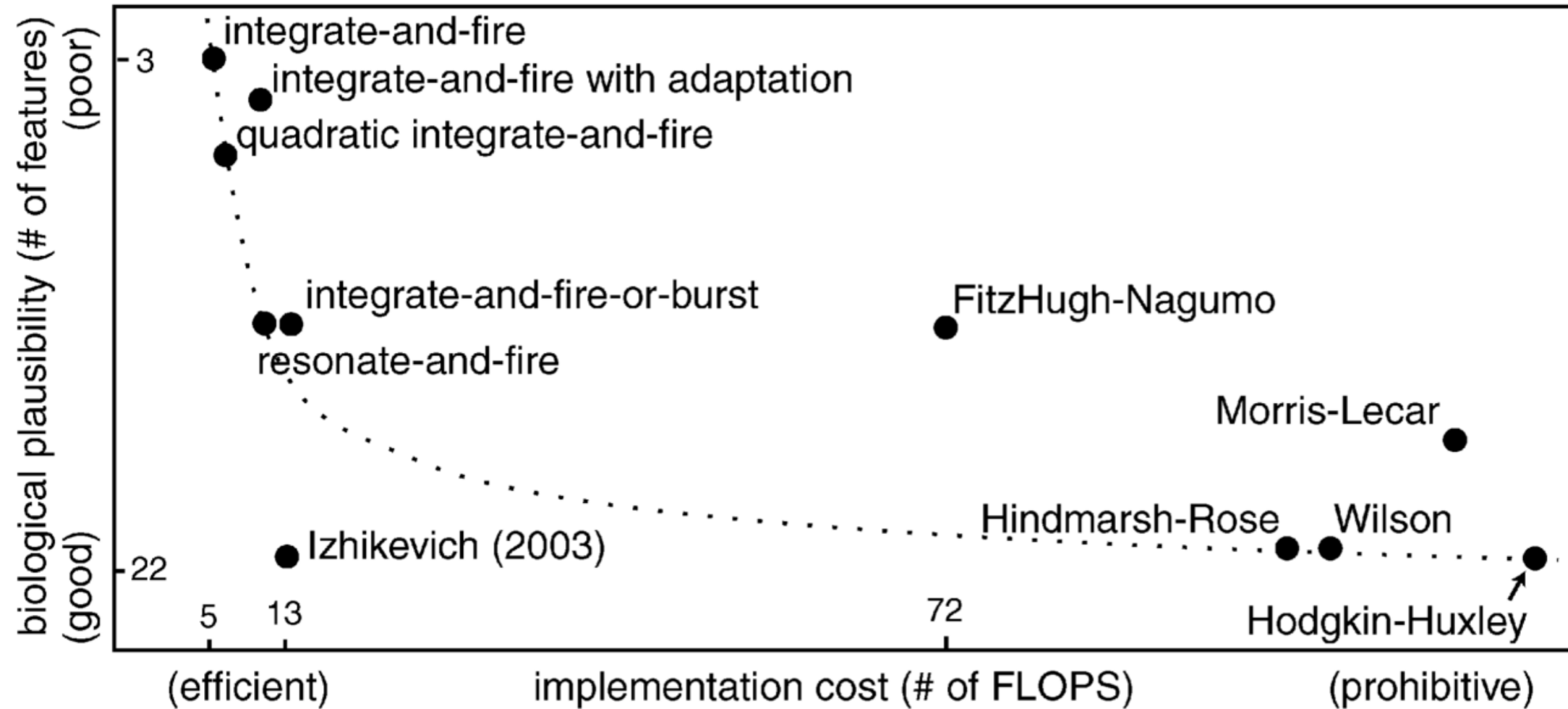

Circuits

The biological synapse

Excitatory synapses excite (depolarize) the postsynaptic cell via excitatory post-synaptic potential (EPSP)

Inhibitory synapses inhibit (hyperpolarize) the postsynaptic cell via inhibitory post-synaptic potential (IPSP)

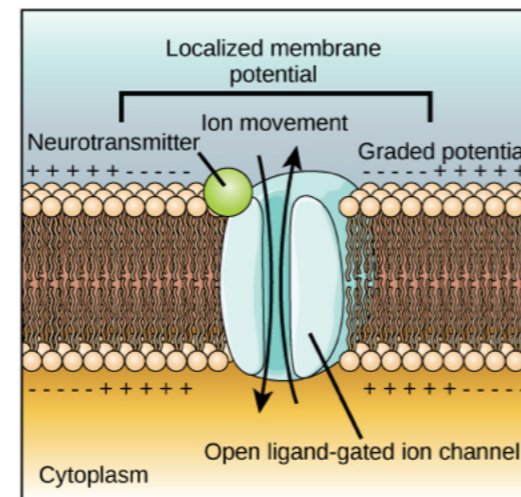
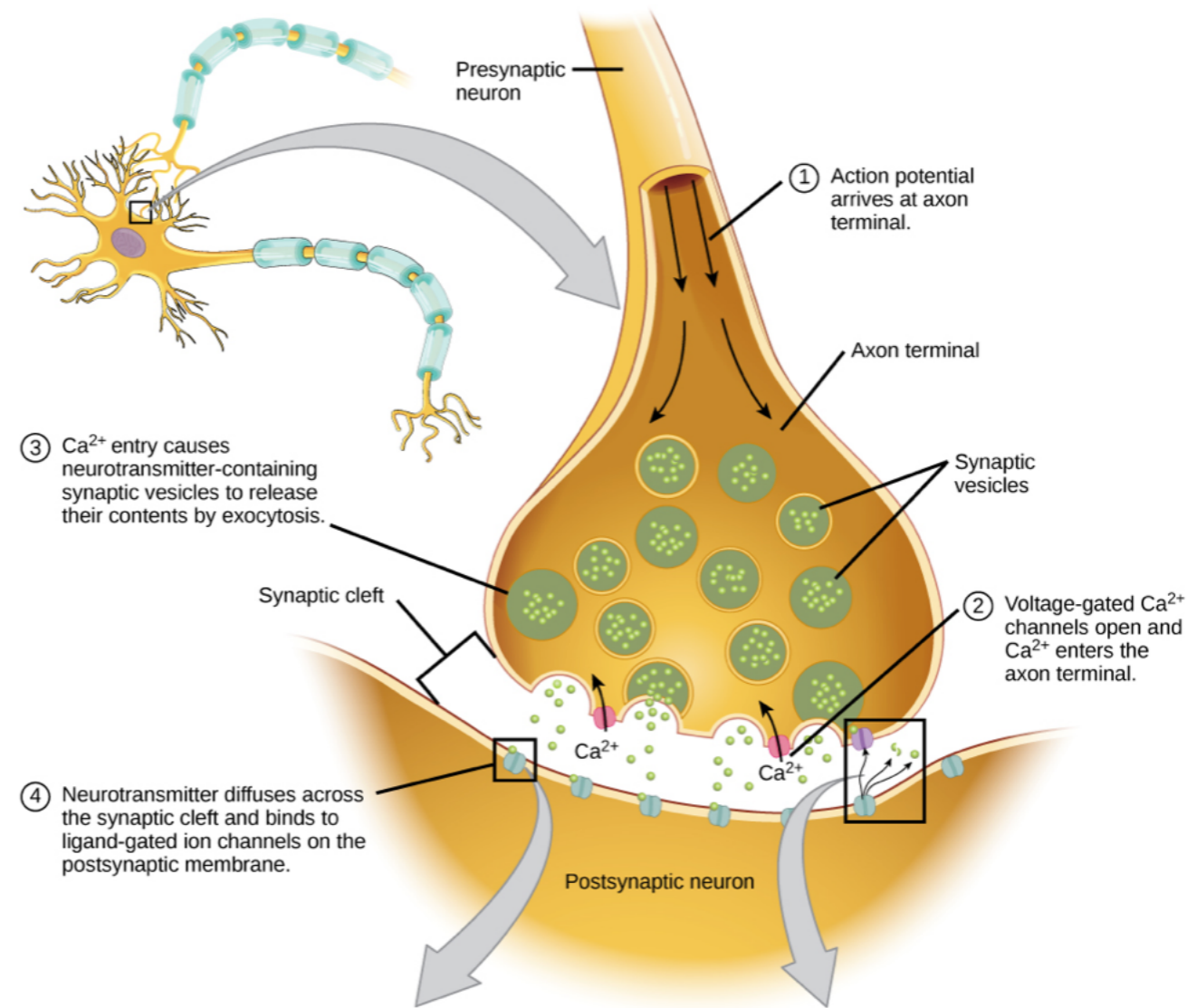
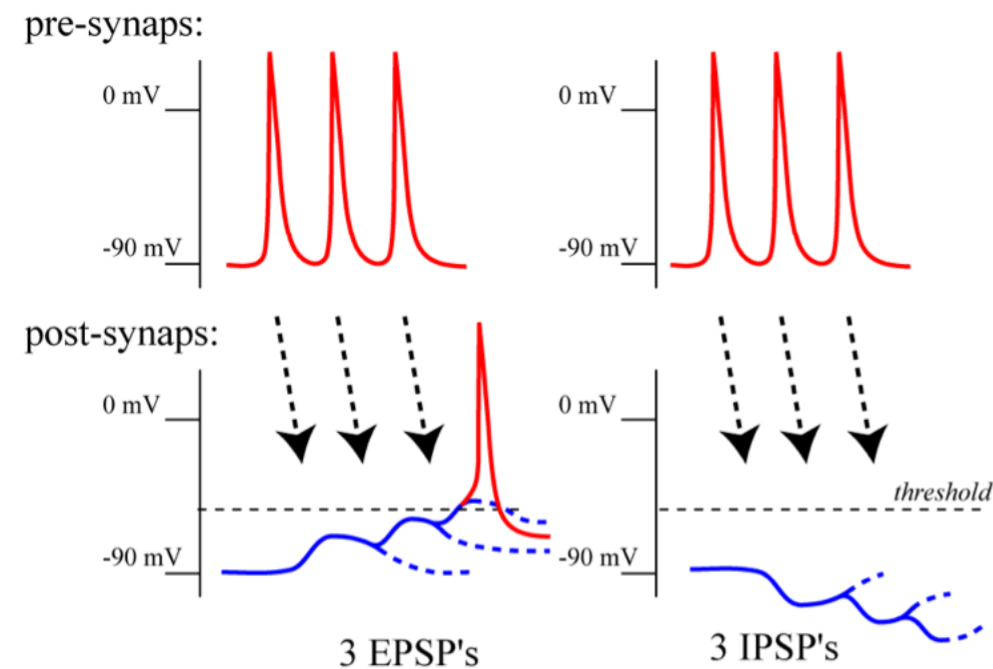

⑤ Binding of neurotransmitter opens ligand-gated ion channels, resulting in graded potentials.

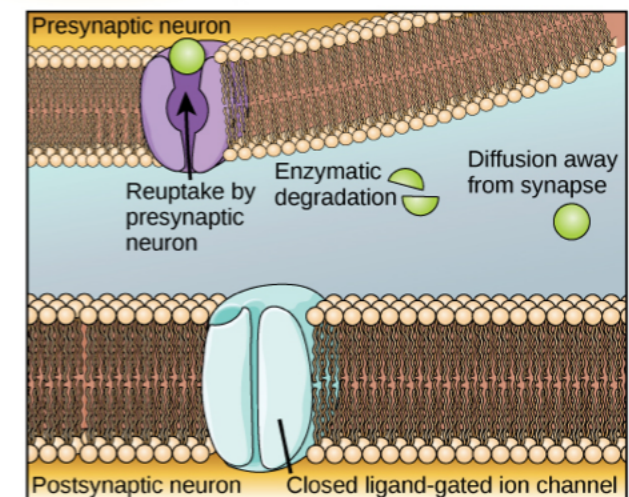

⑥ Reuptake by the presynaptic neuron, enzymatic degradation, and diffusion reduce neurotransmitter levels, terminating the signal.

Neural circuits

A. Feedforward excitation



B. Feedforward inhibition



C. Convergence/divergence



D. Lateral inhibition



E. Feedback/Recurrent inhibition



F. Feedback/Recurrent excitation



E2



F2



Instantaneous connections in a small network

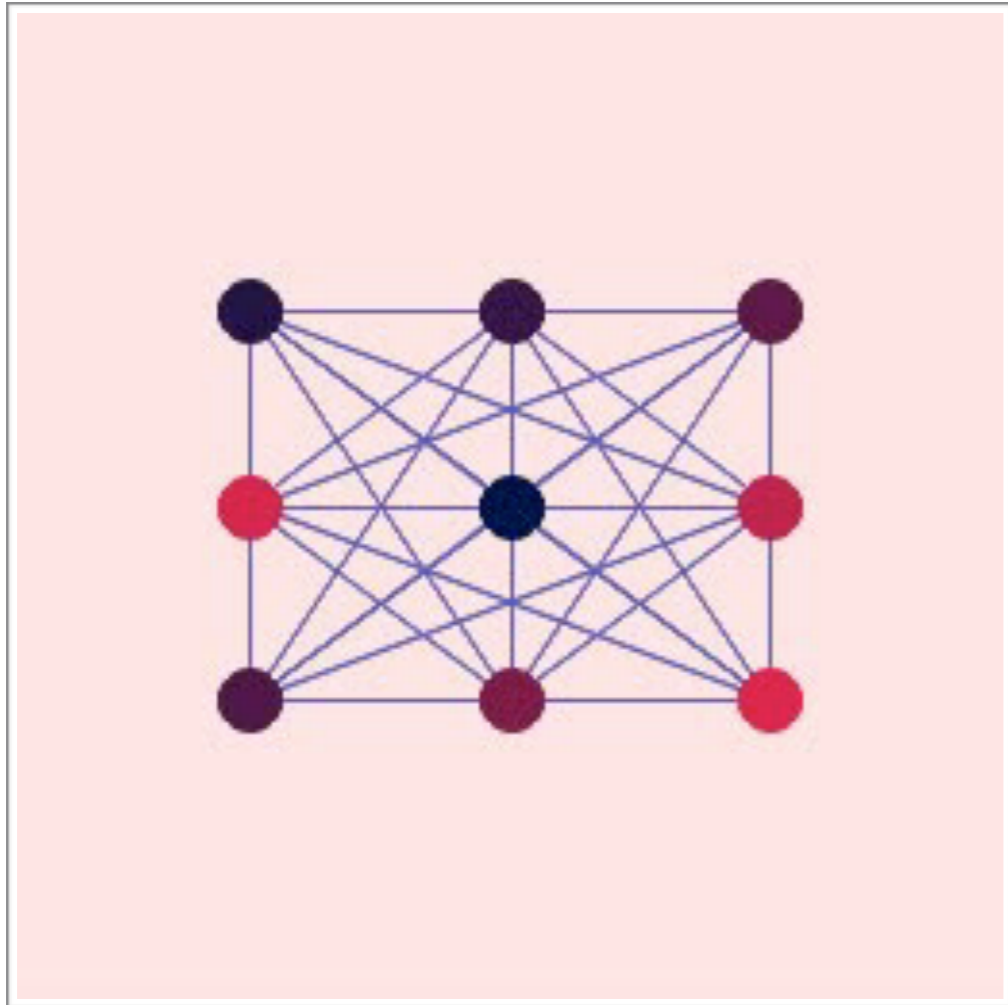

Instantaneous excitatory connections
synchronization

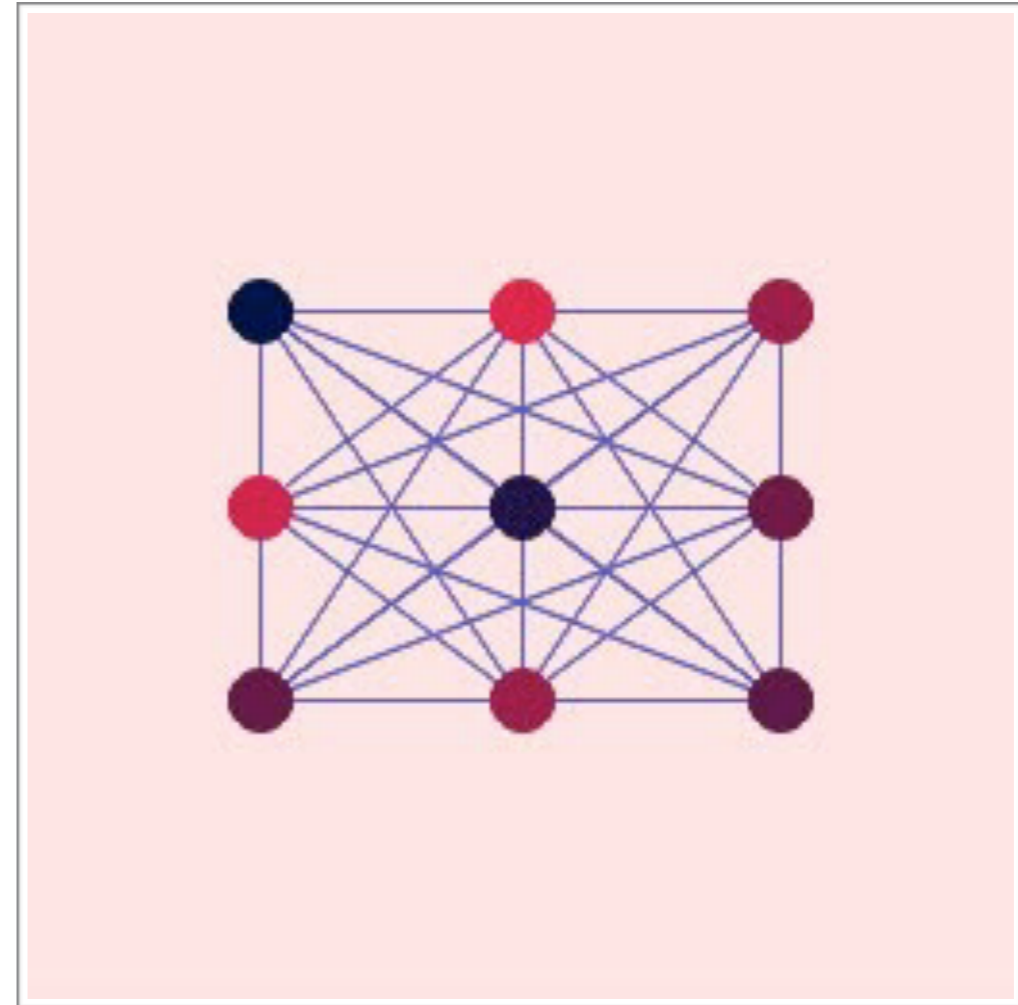

Instantaneous inhibitory connections
no synchronization

Delayed connections in a small network

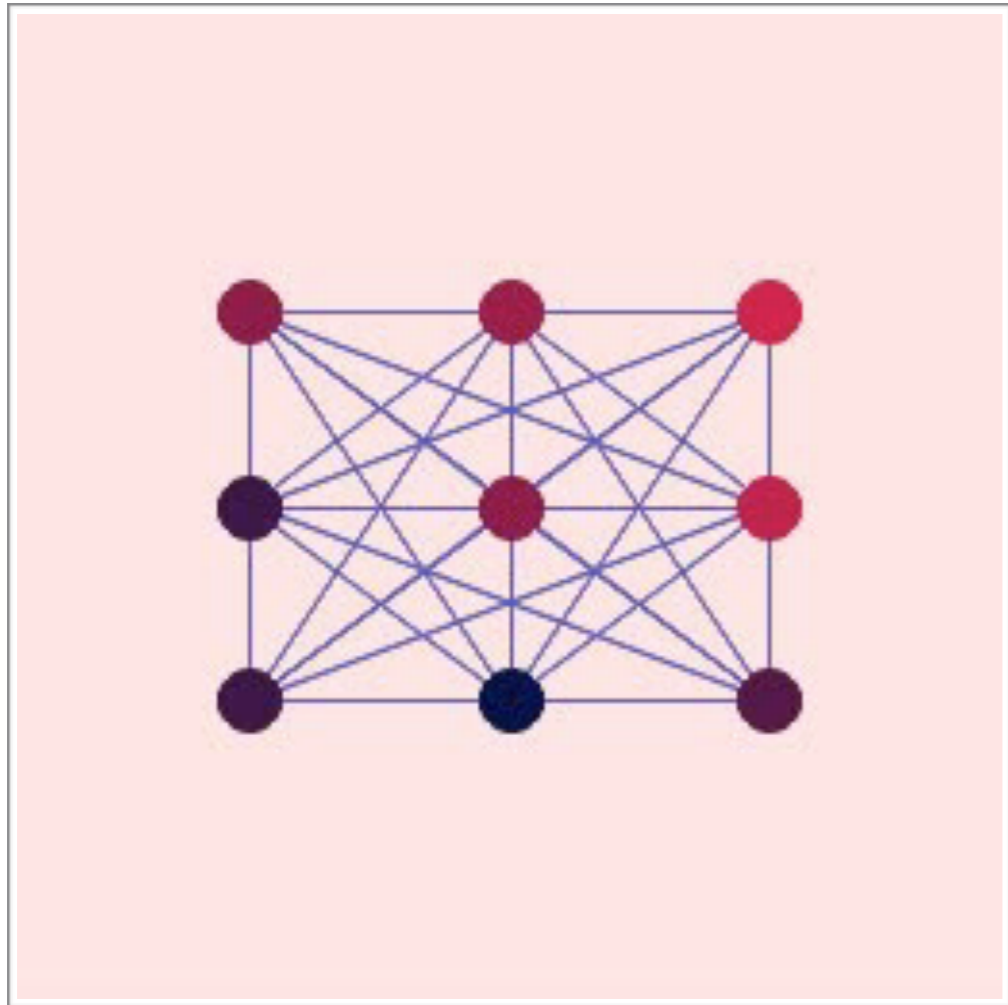

Delayed excitatory connections
no synchronization

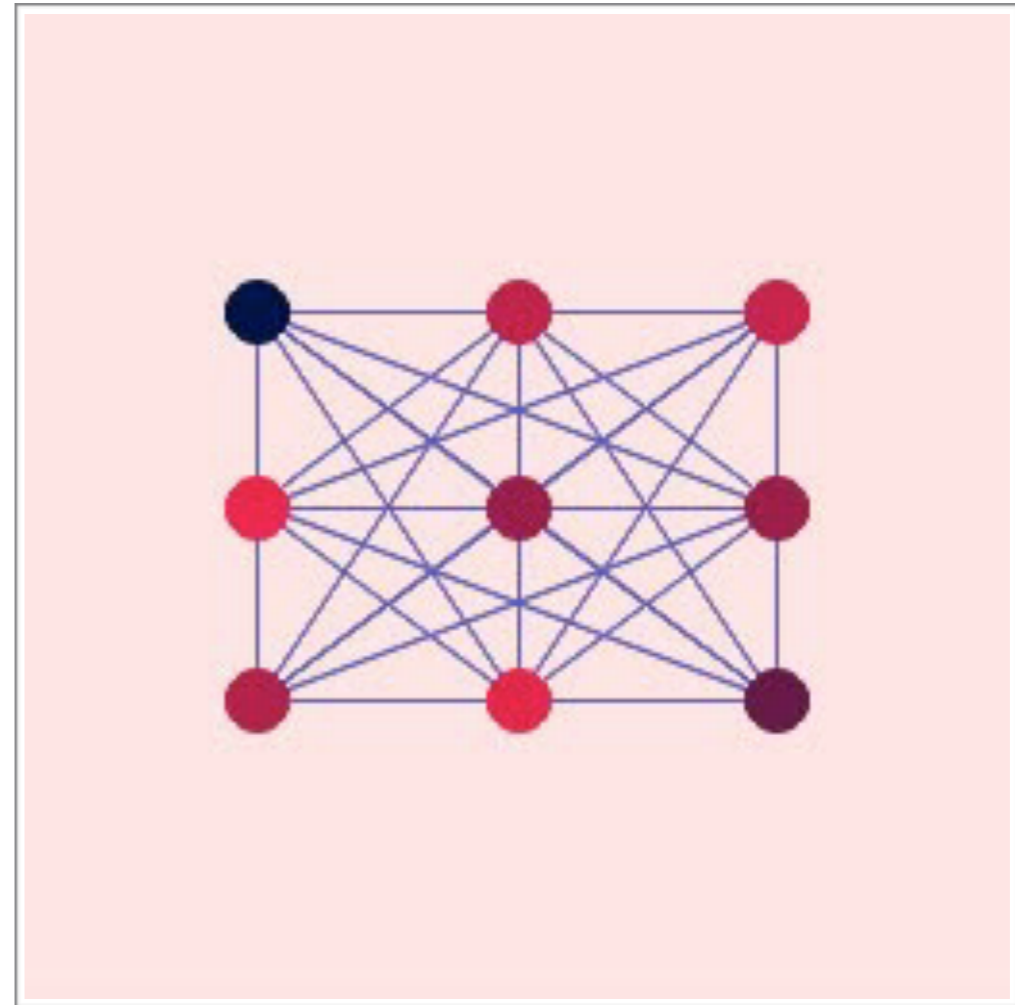

Delayed inhibitory connections
synchronization

Random population

Simulation (by A.Garenne) of 100,000 Izhikevich neurons. sparsely and randomly connected (patchy connections)

→ No input but spontaneous activity because of noise

→ Spontaneous bursts of activity (centrifugal propagating wave)

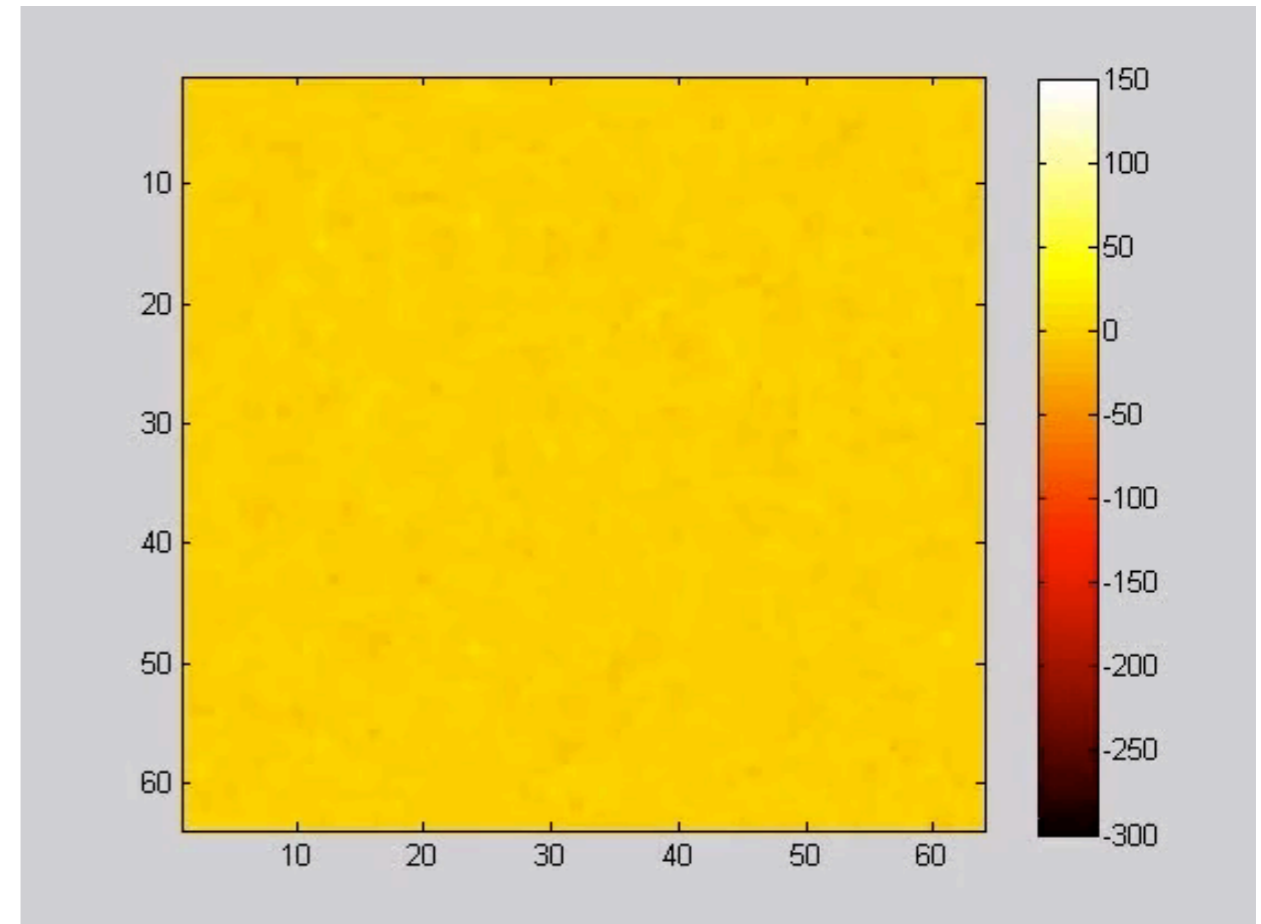
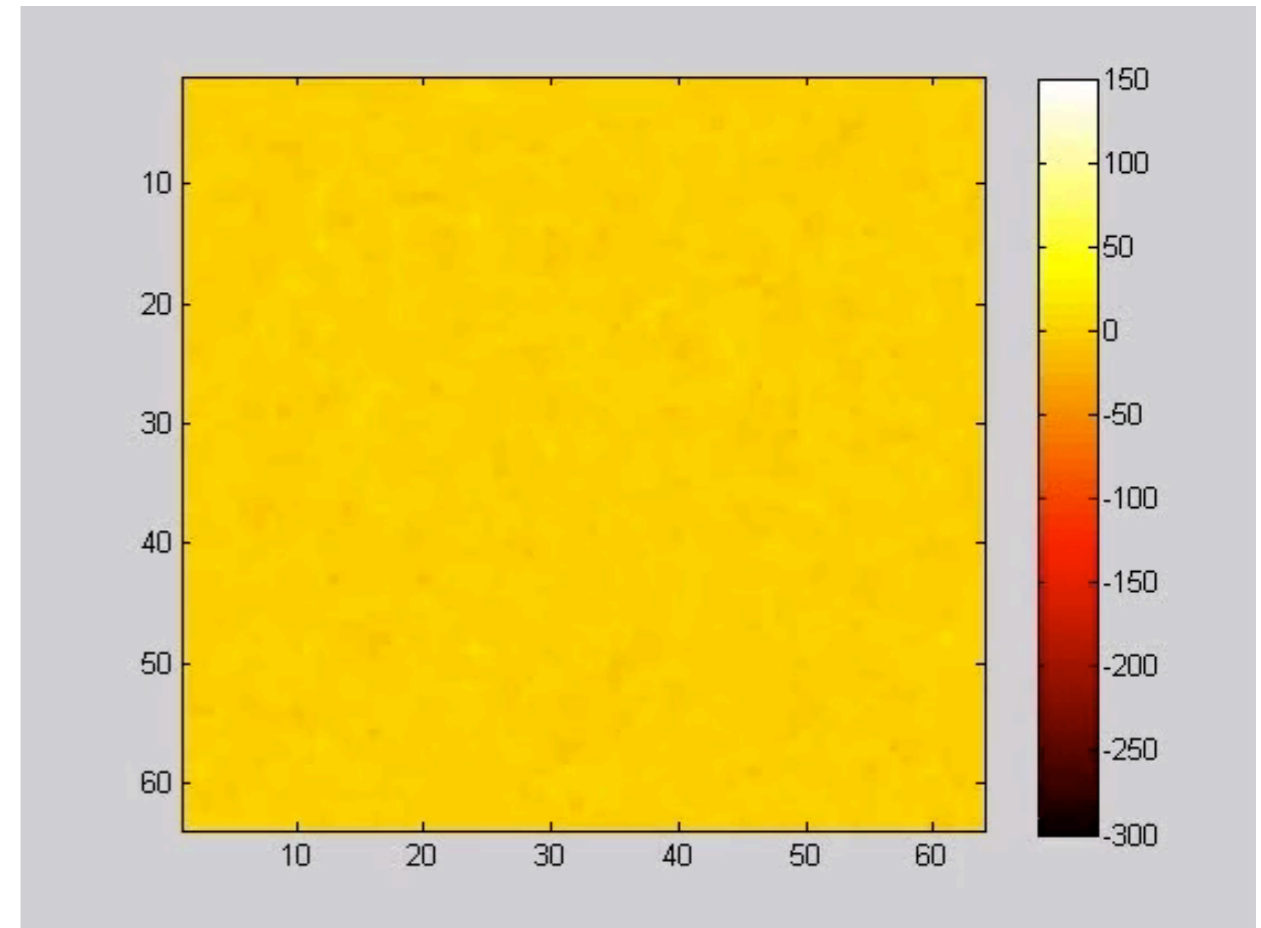

Structured population

Max Planck Florida Institute scientists create first realistic 3D reconstruction of all nerve cell bodies in a cortical column in the whisker system of rats. The colour indicates the cell type of the nerve cell.

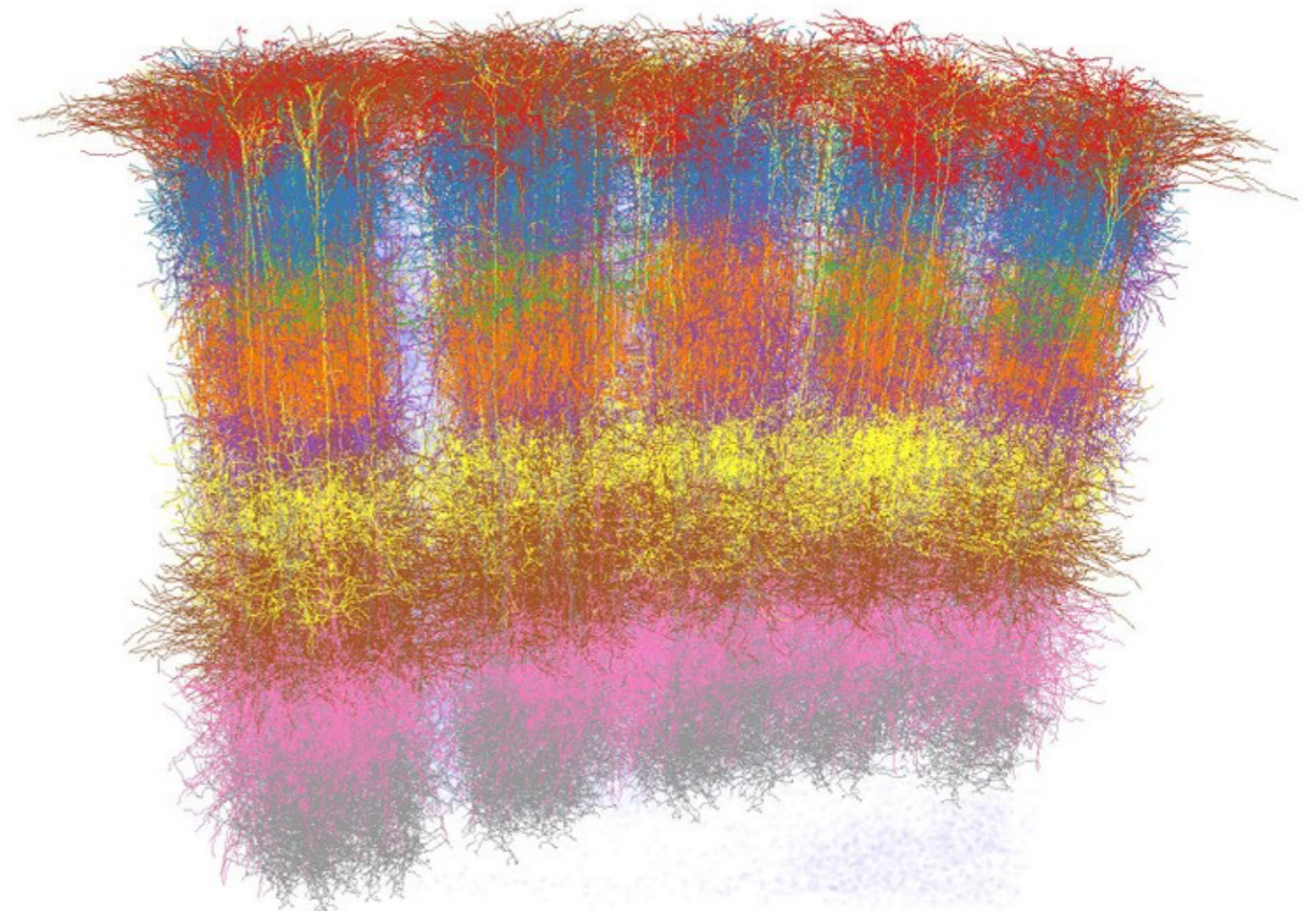
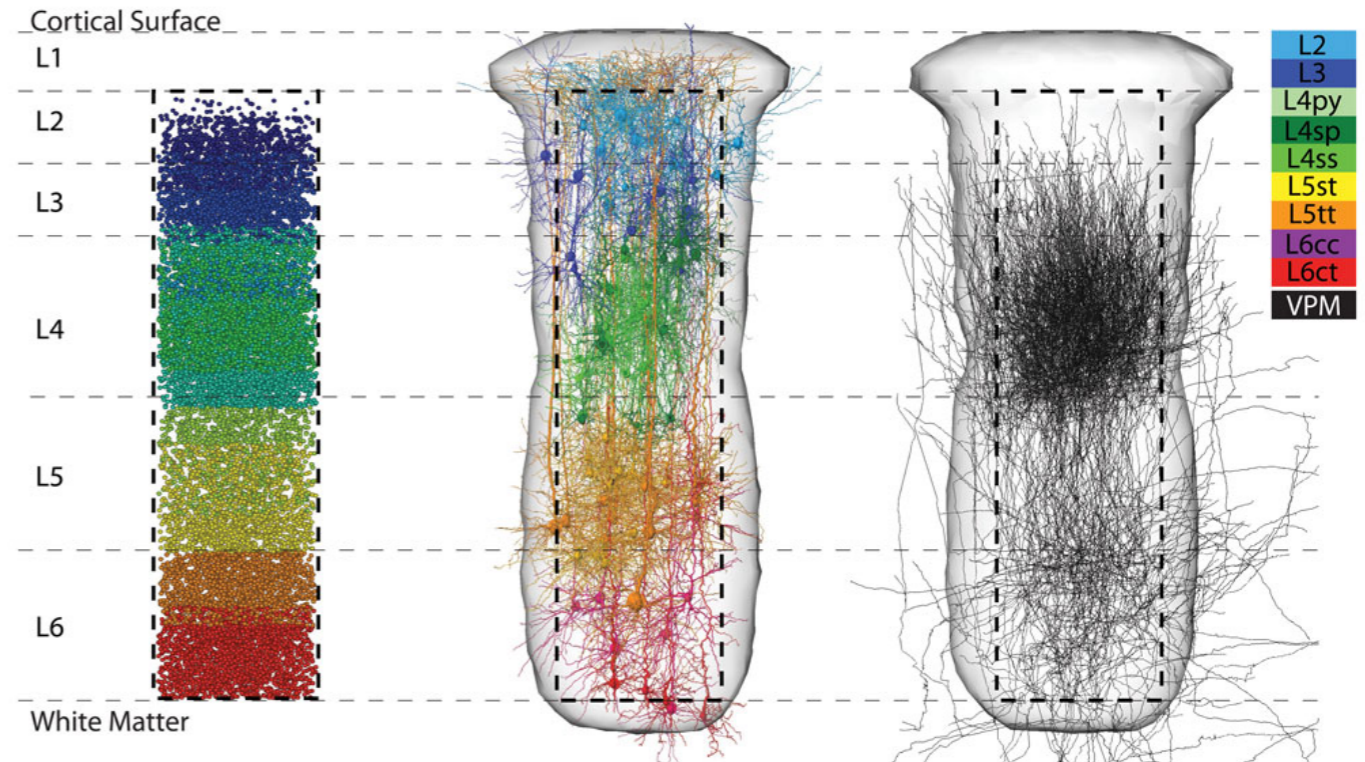

Neural Coding

What information is conveyed by spikes ?

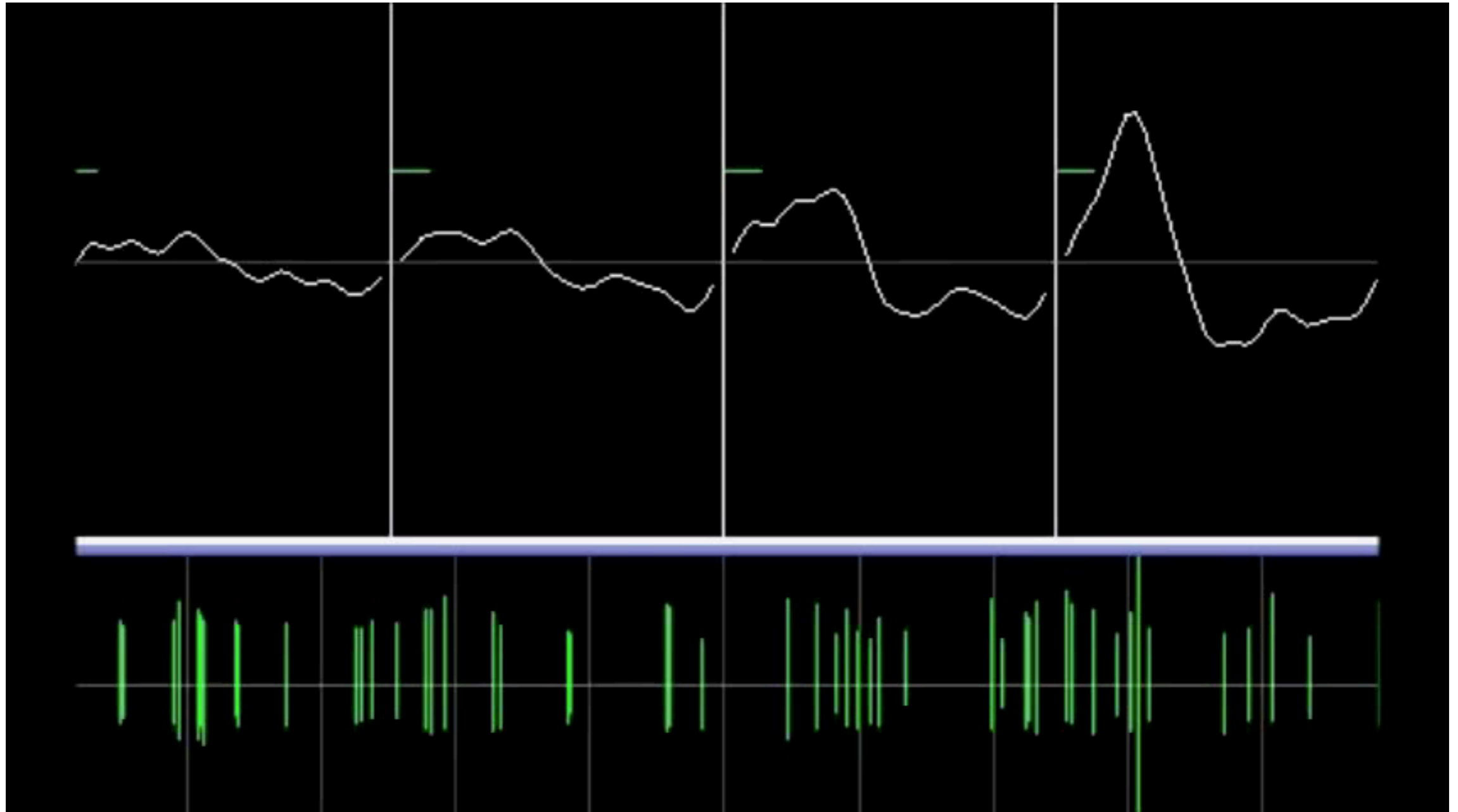

Temporal coding

- Rank order (Thorpe & Gautrais, 1991)
→ most of the information about a new stimulus is conveyed during the first 20 or 50 milliseconds after the onset of the neuronal response



Temporal coding

- Rank order (Thorpe & Gautrais, 1991)
→ most of the information about a new stimulus is conveyed during the first 20 or 50 milliseconds after the onset of the neuronal response
- Synchrony (Wang & Terman, 1995)
→ synchrony between a pair or many neurons could signify special events and convey information which is not contained in the firing rate of the neurons
- Etc...

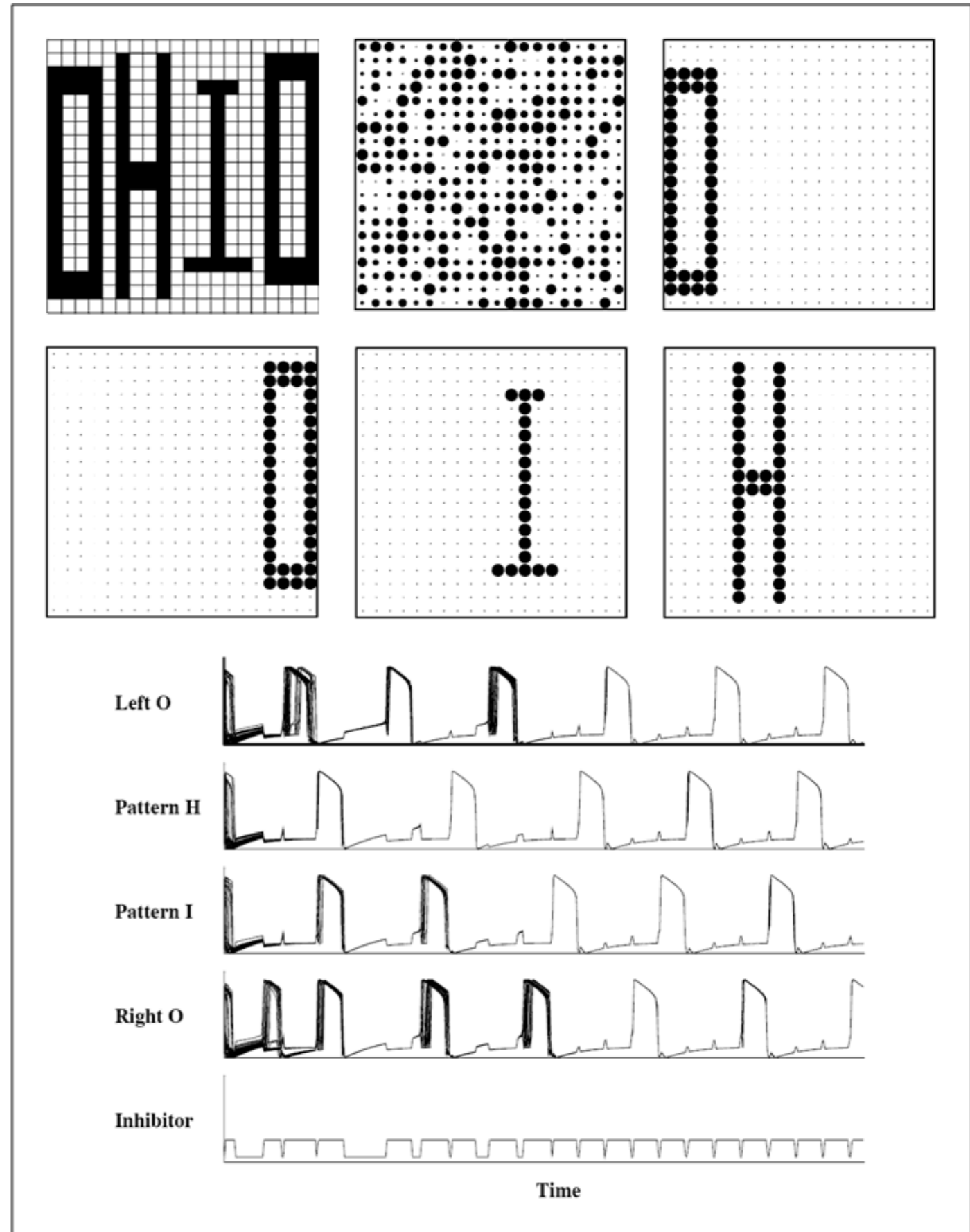

Rate coding

But spike trains are not reliable...

- Average over time
→ the spike count in an interval of duration T
- Average over population
→ the spike count during in a population of size N in an interval of duration dt
- Average over runs
→ the spike count for N runs in an interval of duration dt

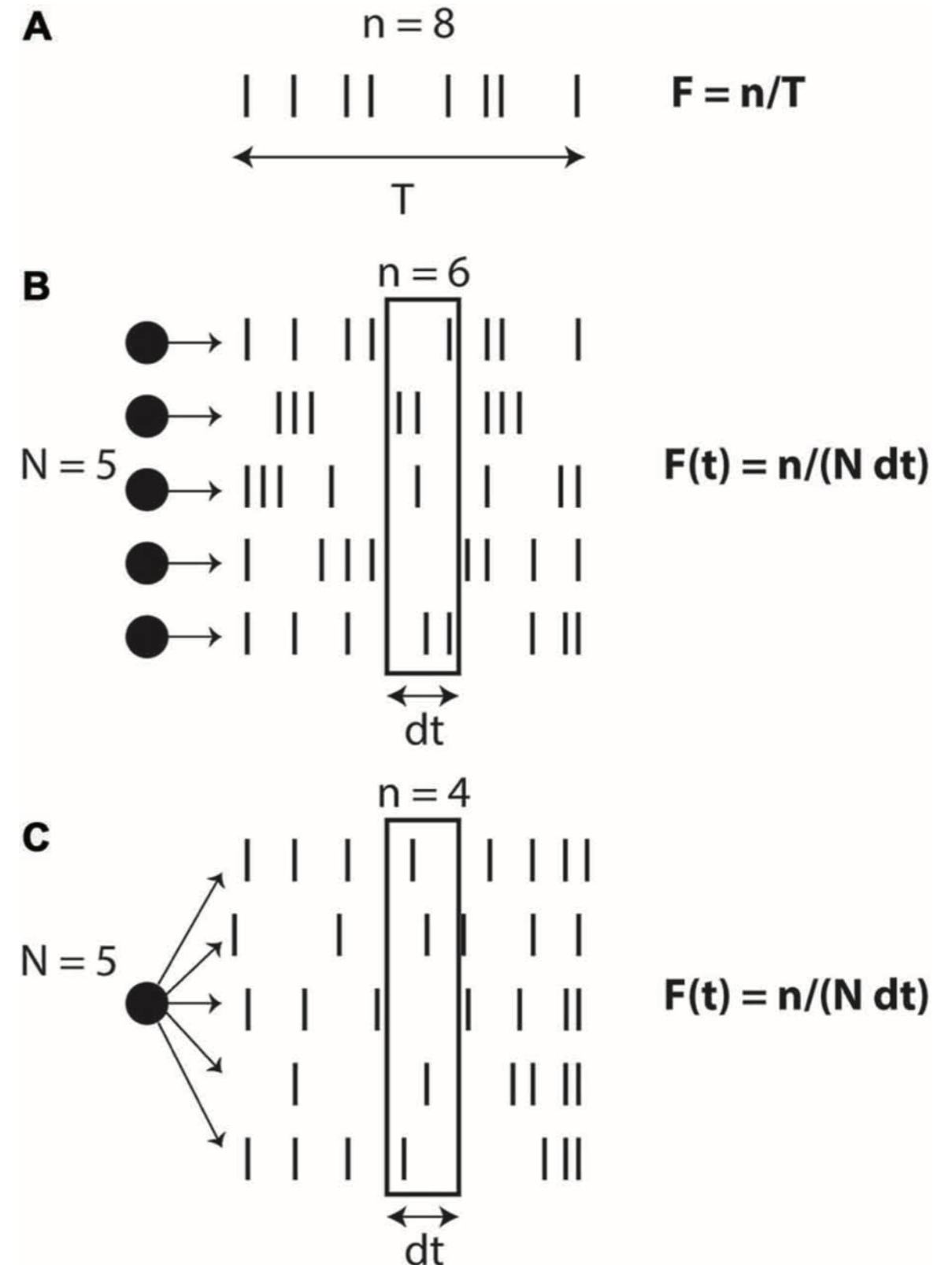

Rate models

To model a rate model, no need to first model a spiking neuron and then compute the rate code.

Better use a direct model instead.

$$\tau dV/dt = -V + I_{syn} + I_{ext}$$

But not enough time today...

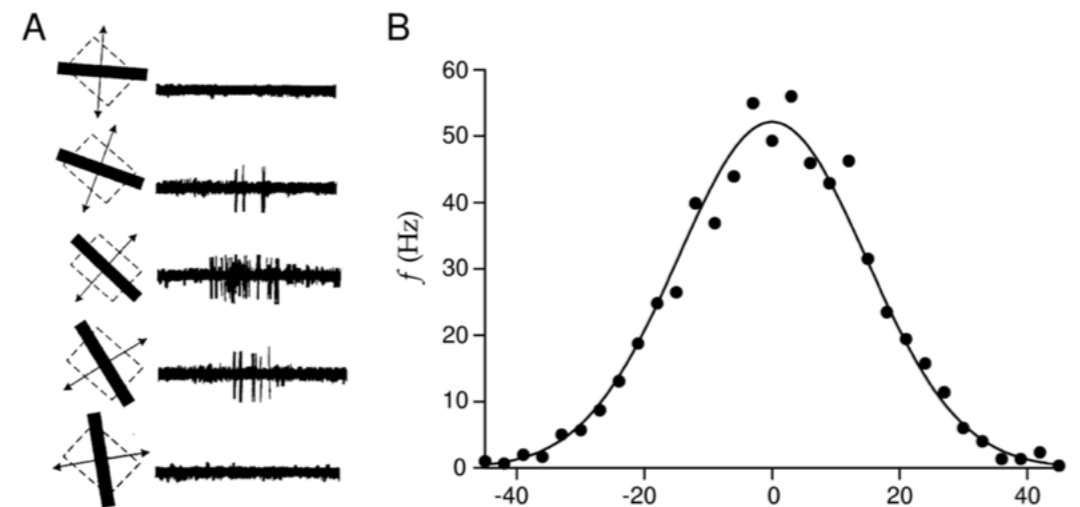
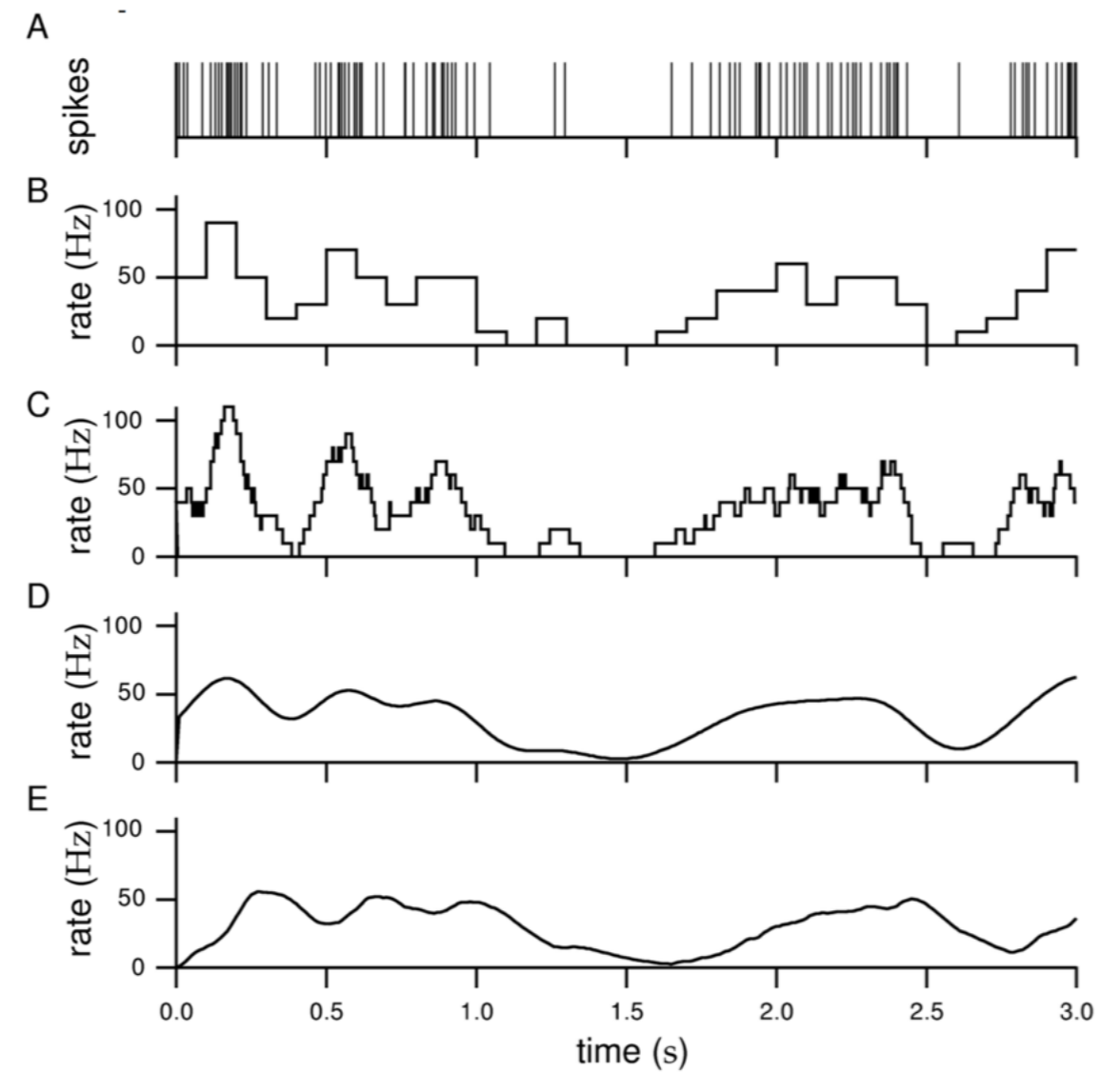

Population

Between cells and tissue

The number of neurons and synapses in even a small piece of cortex is immense. Because of this a popular modelling approach (Wilson & Cowan, 1973) has been to take a continuum limit and study neural networks in which space is continuous and macroscopic state variables are mean firing rates.

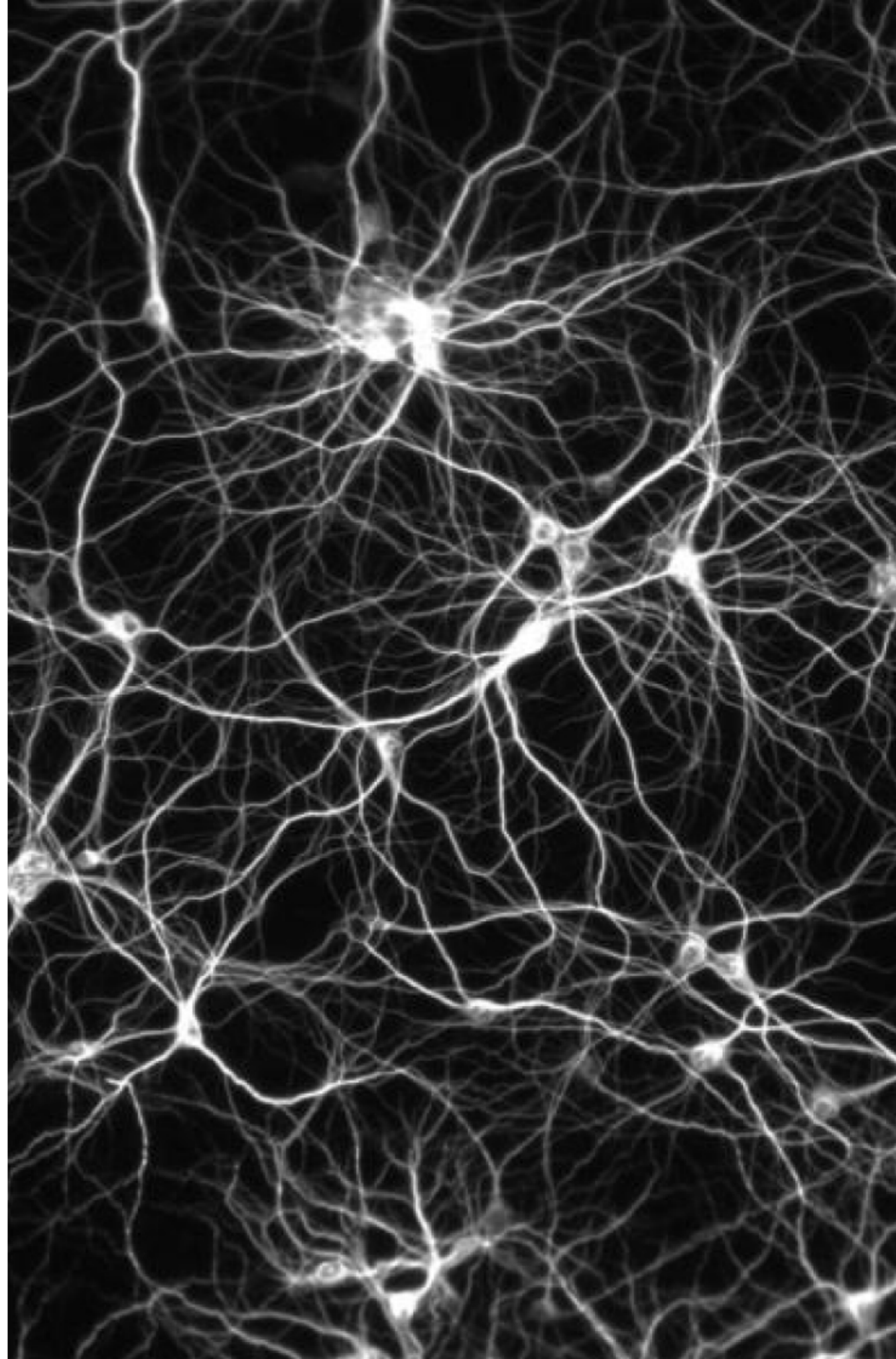

Neural fields

We consider a small piece of cortex to be a continuum (Ω). The membrane potential $u(x,t)$ at any point x is a function of other the input current and the lateral interaction.

$$\tau \frac{\partial u(x, t)}{\partial t} = -u(x, t) + \int_{\Omega} w(x, y) f(u(y, t)) dy + I(x, t) + h$$

The $w(x,y)$ function is generally a difference of Gaussian (a Mexican hat).

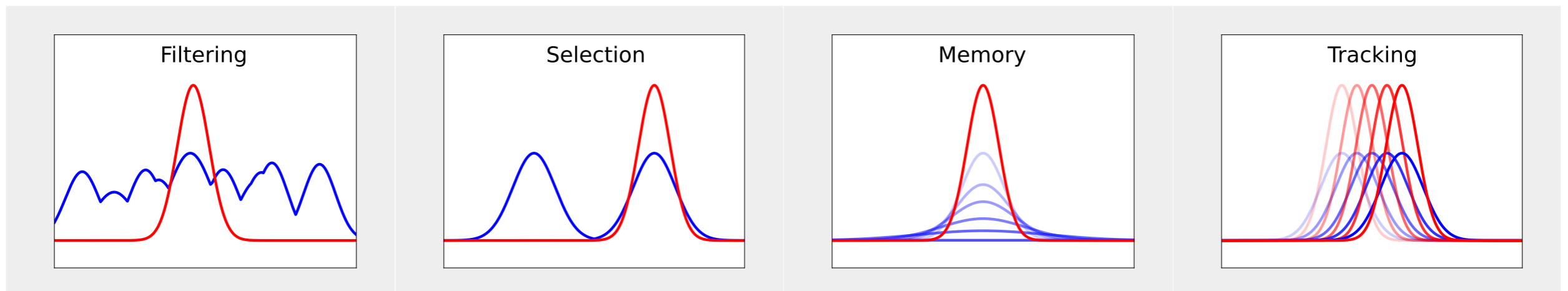

Visual attention

(Vitay & Rougier, 2008)

Several studies suggest that the population of active neurons in the superior colliculus encodes the location of a visual target to foveate, pursue or attend to.

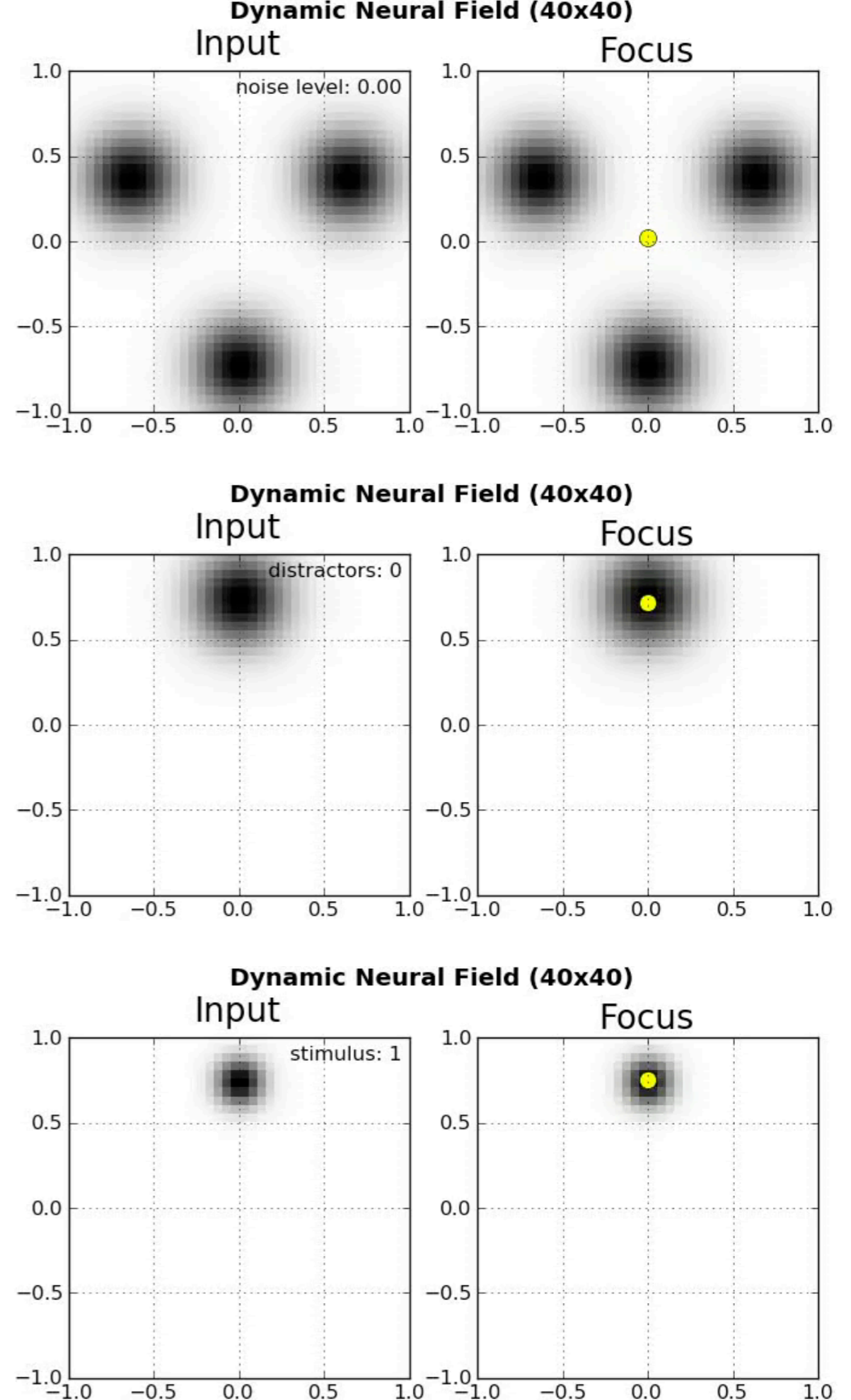

A clockwork orange

Using the output of the focus map we can control a robot.

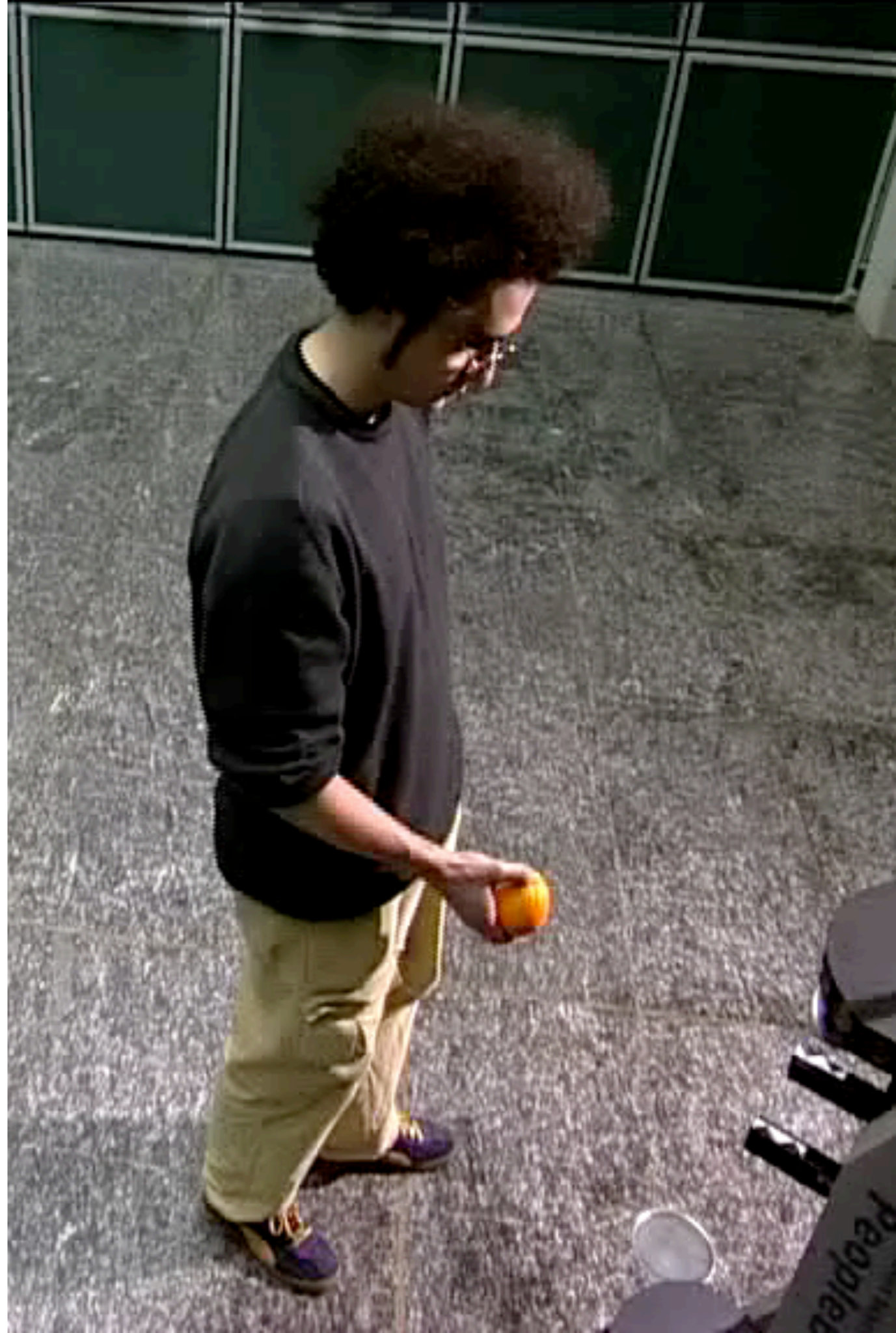
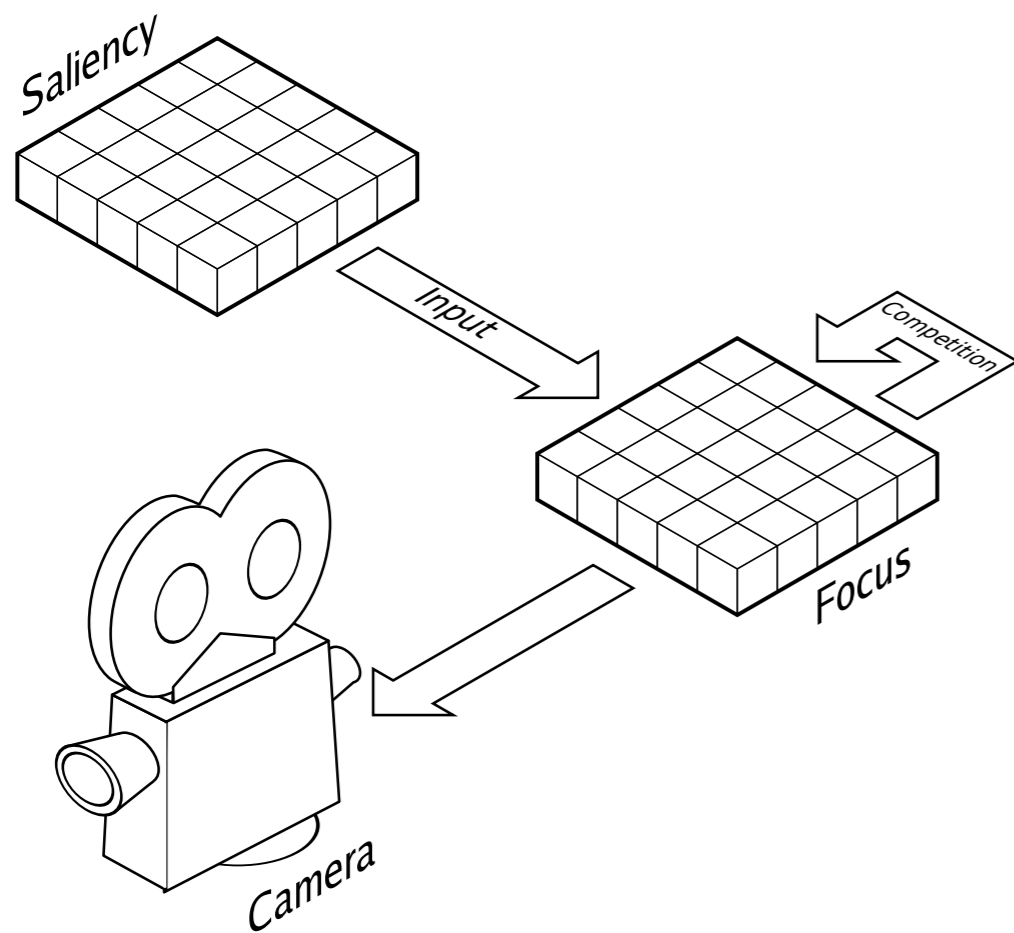

Plasticity & learning

Plasticity

Synaptic plasticity is the ability of synapses to strengthen or weaken over time, in response to increases or decreases in their activity

Structural plasticity is the reorganisation of synaptic connections through sprouting or pruning.

Intrinsic plasticity is the persistent modification of a neuron's intrinsic electrical properties by neuronal or synaptic activity

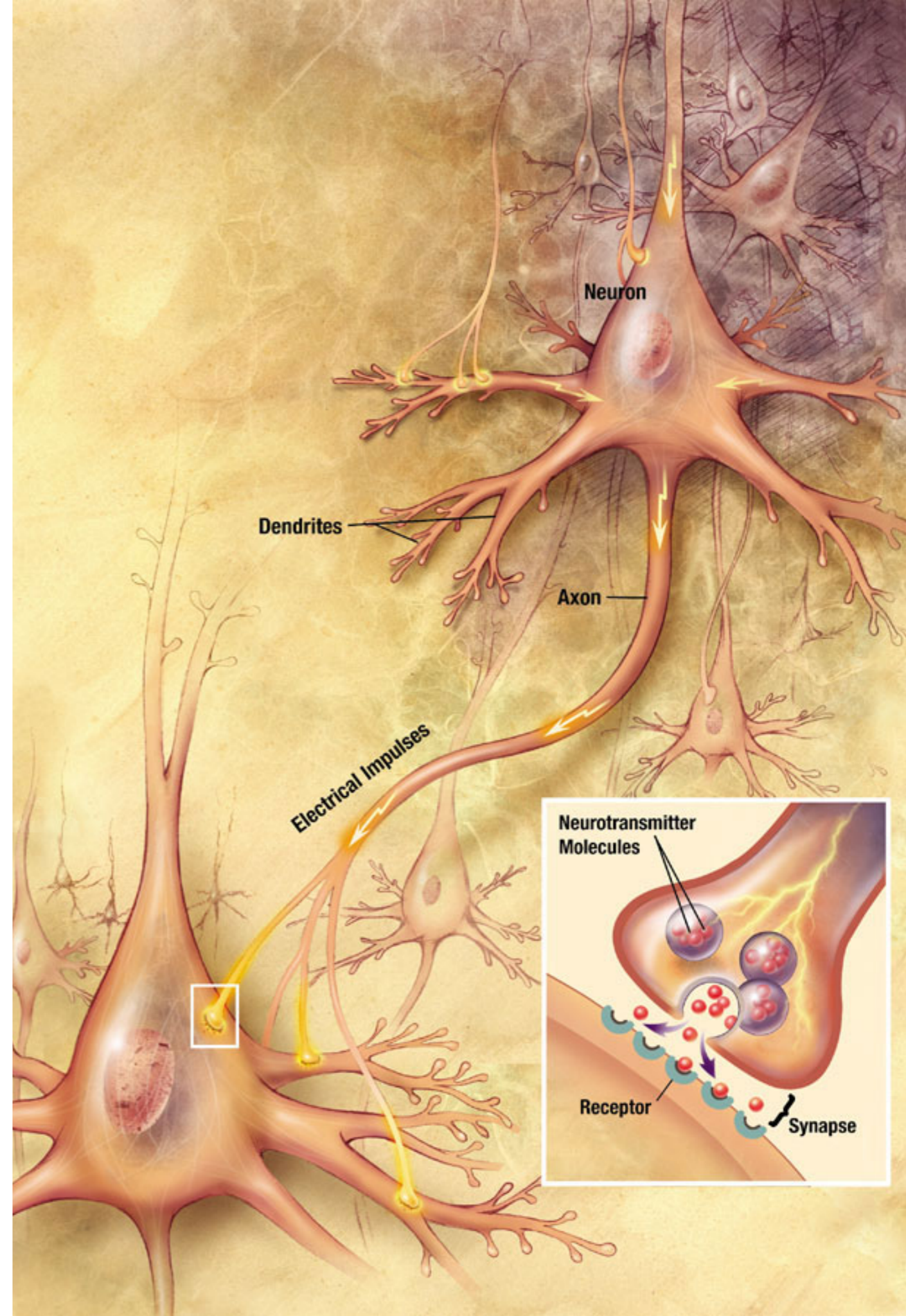

Hebb's Postulate: fire together, wire together

When an axon of cell A is near enough to excite a cell B and repeatedly or persistently takes part in firing it, some growth process or metabolic change takes place in one or both cells such that A's efficiency, as one of the cells firing B, is increased (Hebb, 1949).

Problem is that weights are not bounded and cannot decrease. Usually, uniform forgetting or an anti-Hebbian rule is added to cope with this problem.

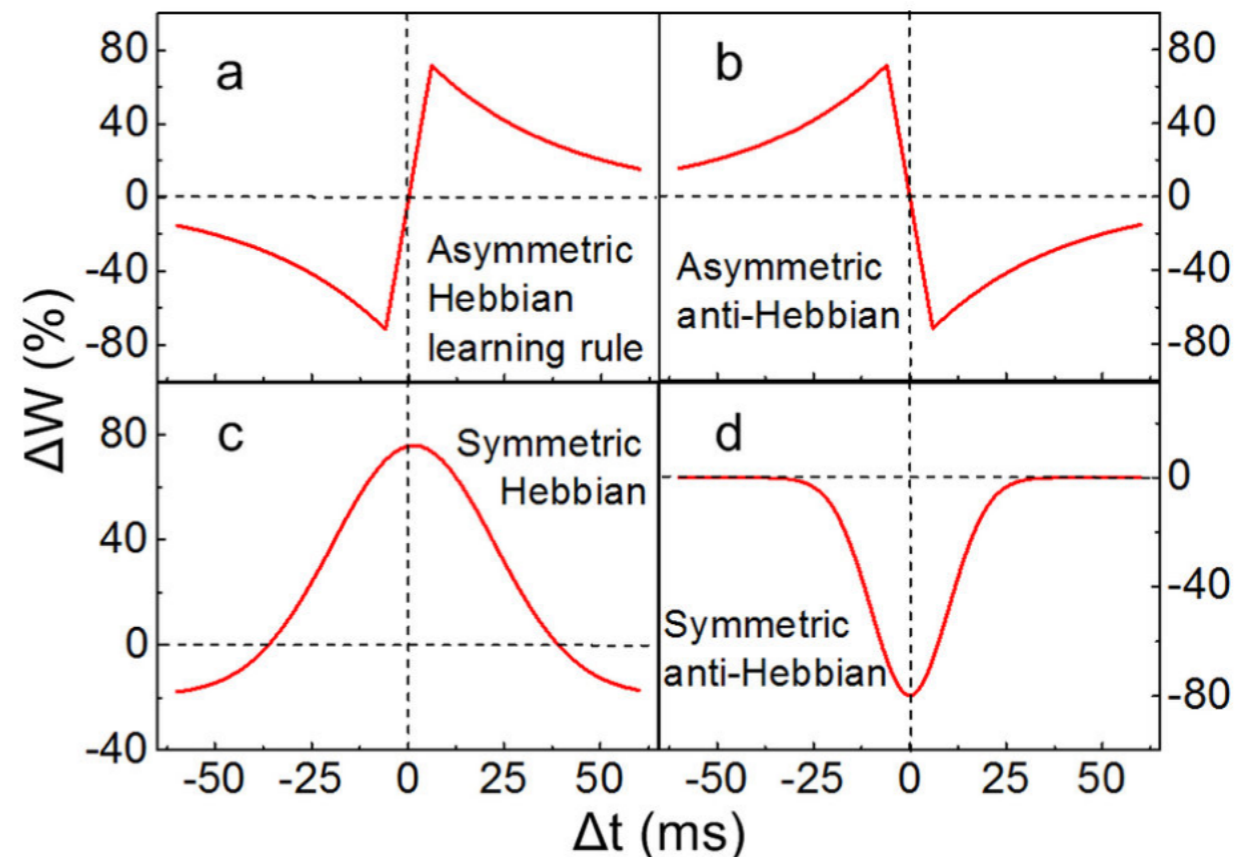

Some plasticity rules

Spike-timing dependent plasticity is a temporally asymmetric form of Hebbian learning induced by tight temporal correlations between the spikes of pre- and postsynaptic neurons.

The BCM (Bienenstock, Cooper, and Munro) is characterized by a rule expressing synaptic change as a Hebb-like product of the presynaptic activity and a nonlinear function $\phi(y)$ of the postsynaptic activity, y .

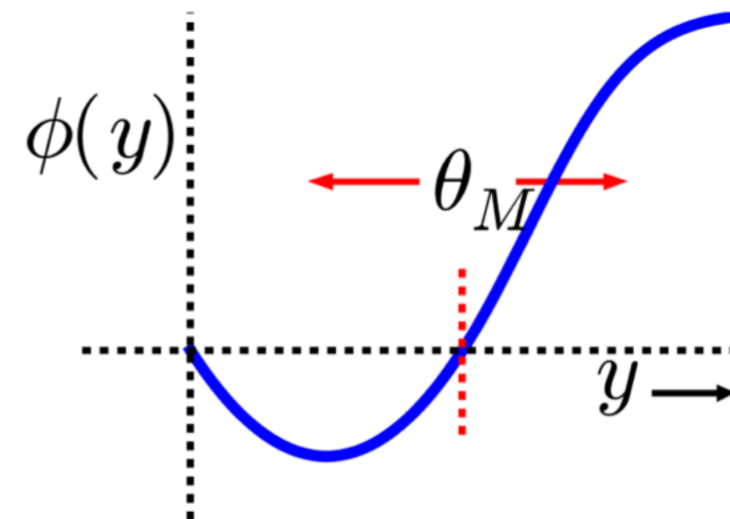
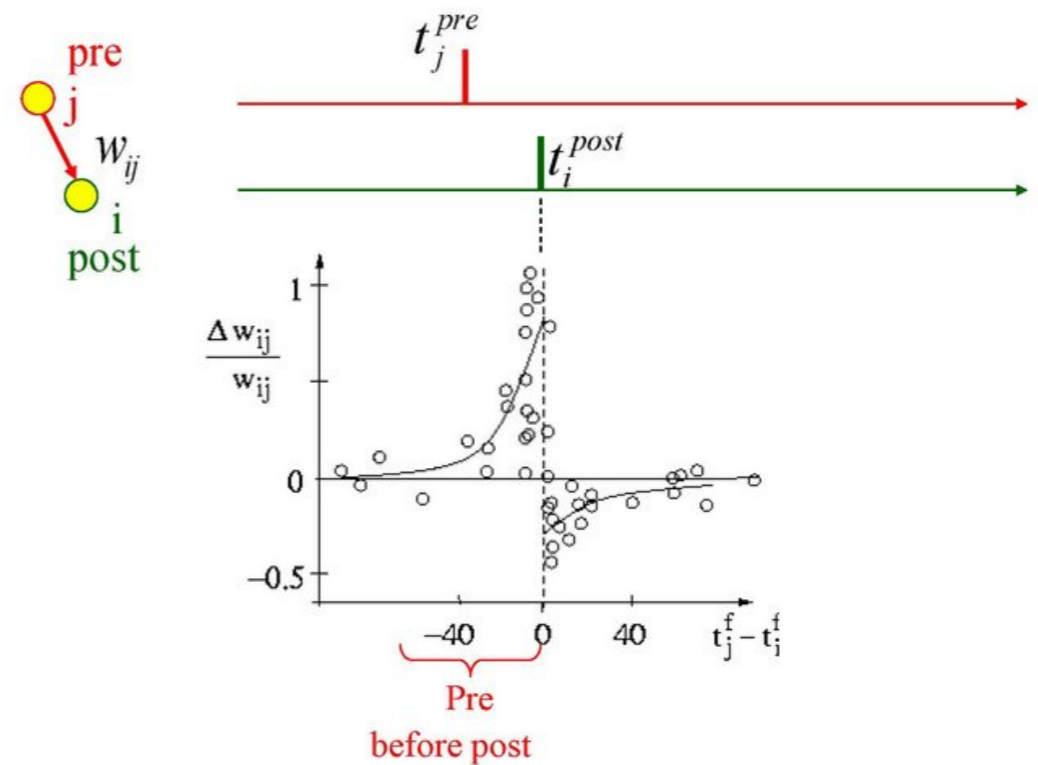

Learning

- The cerebellum is specialized for **supervised learning**, which is guided by the error signal encoded in the climbing fiber input from the inferior olive learning
- The basal ganglia are specialized for **reinforcement learning**, which is guided by the reward signal encoded in the dopaminergic input from the substantia nigra
- The cerebral cortex is specialized for **unsupervised learning**, which is guided by the statistical properties of the input signal itself, but may also be regulated by the ascending neuromodulatory inputs

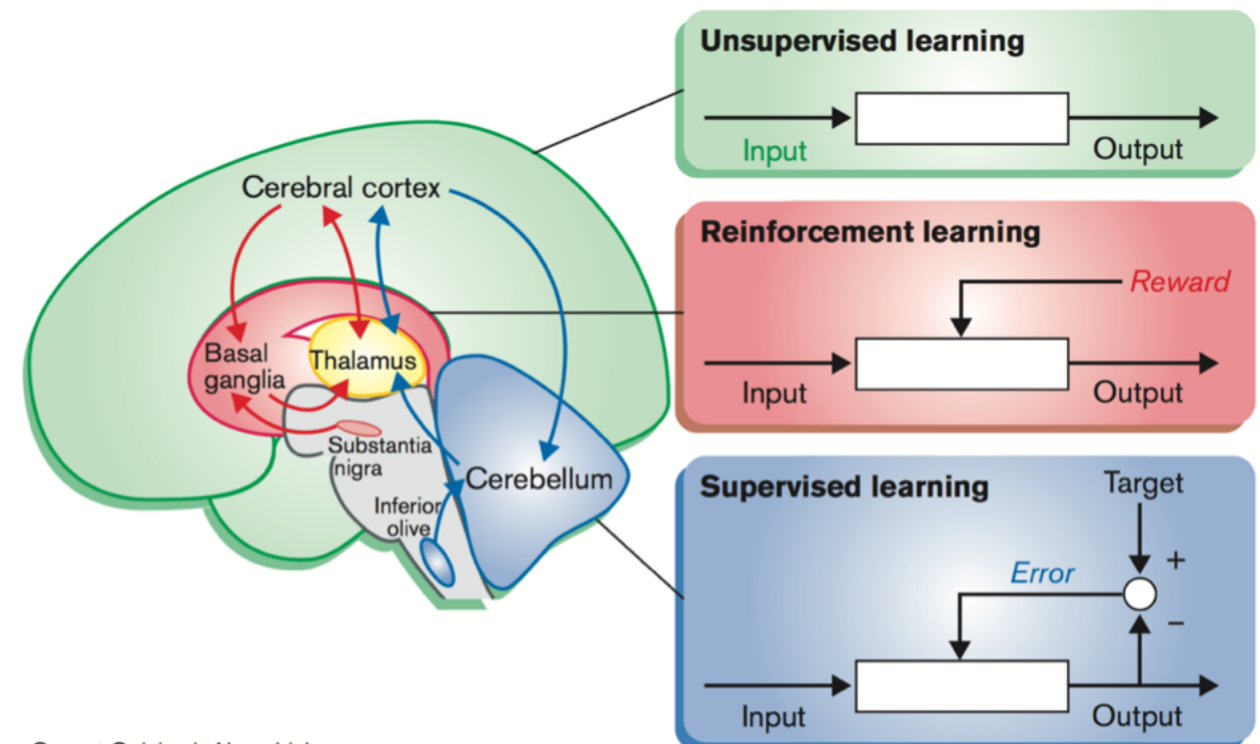

Plasticity in the somatosensory cortex

(Florence, 2002)

A Somatosensory maps in the cortex of the owl monkey

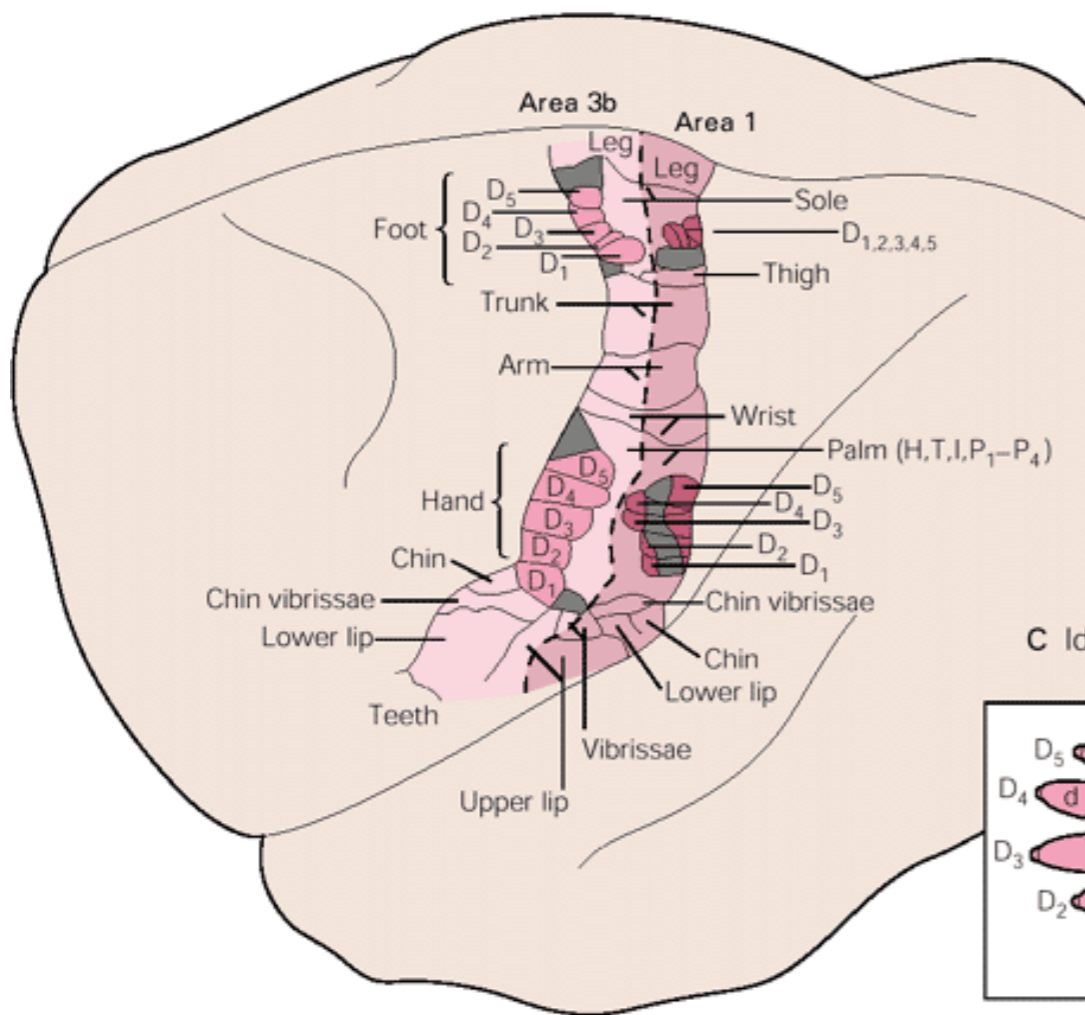

B Detail of representation of the palm

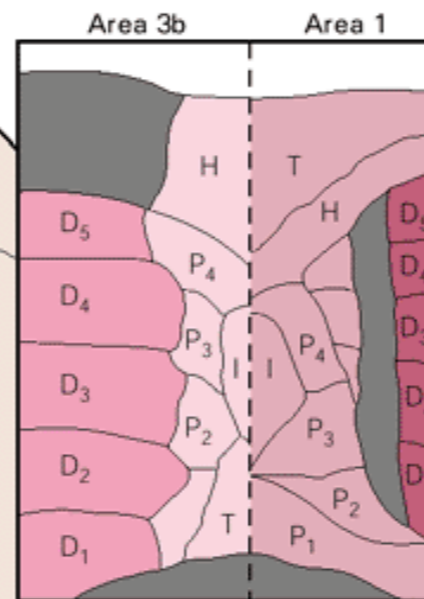

C Idealized somatosensory map of hands

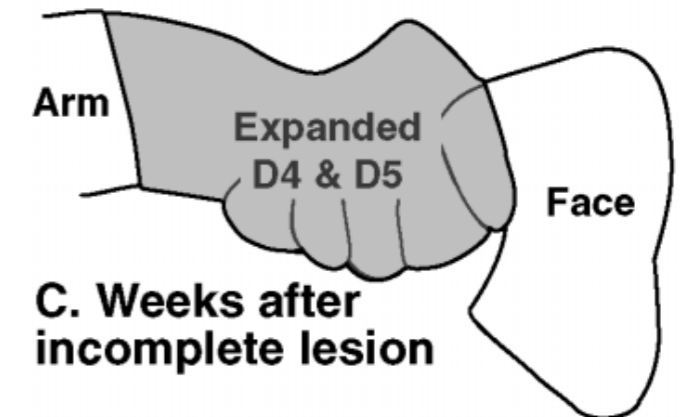
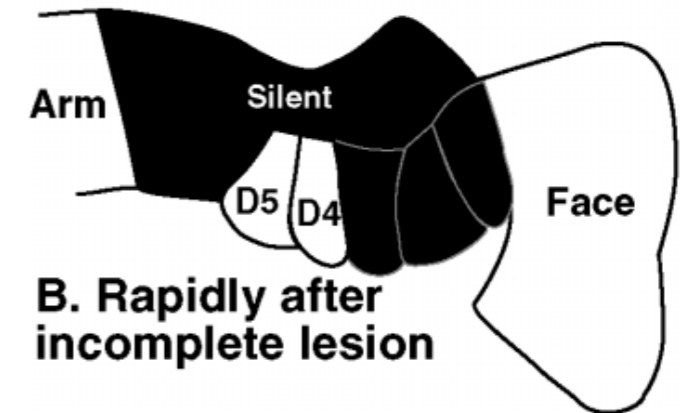
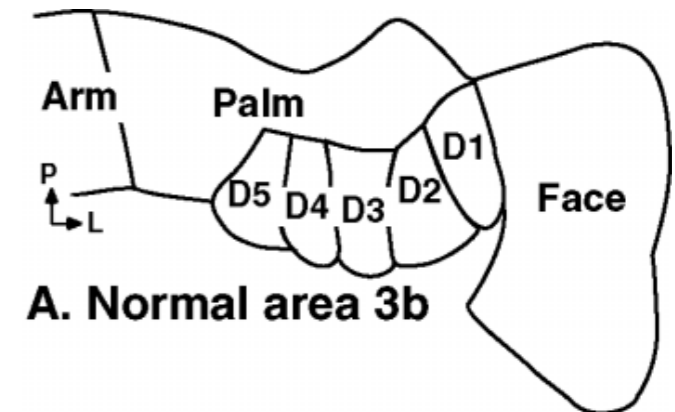
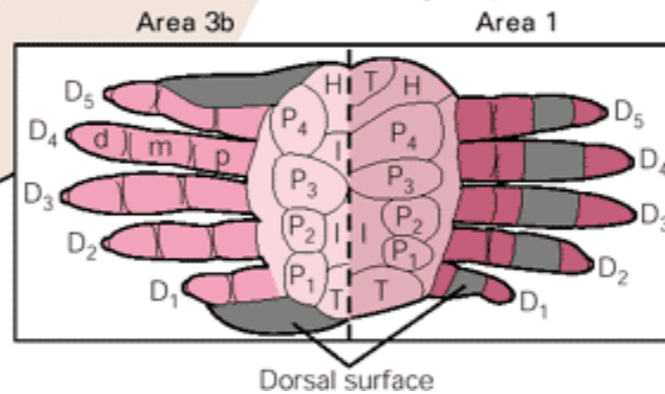

A model of area 3b (Detorakis & Rougier, 2013)

Using a neural field, we've modelled the primary sensory cortex (3b) in the primate using unsupervised learning.

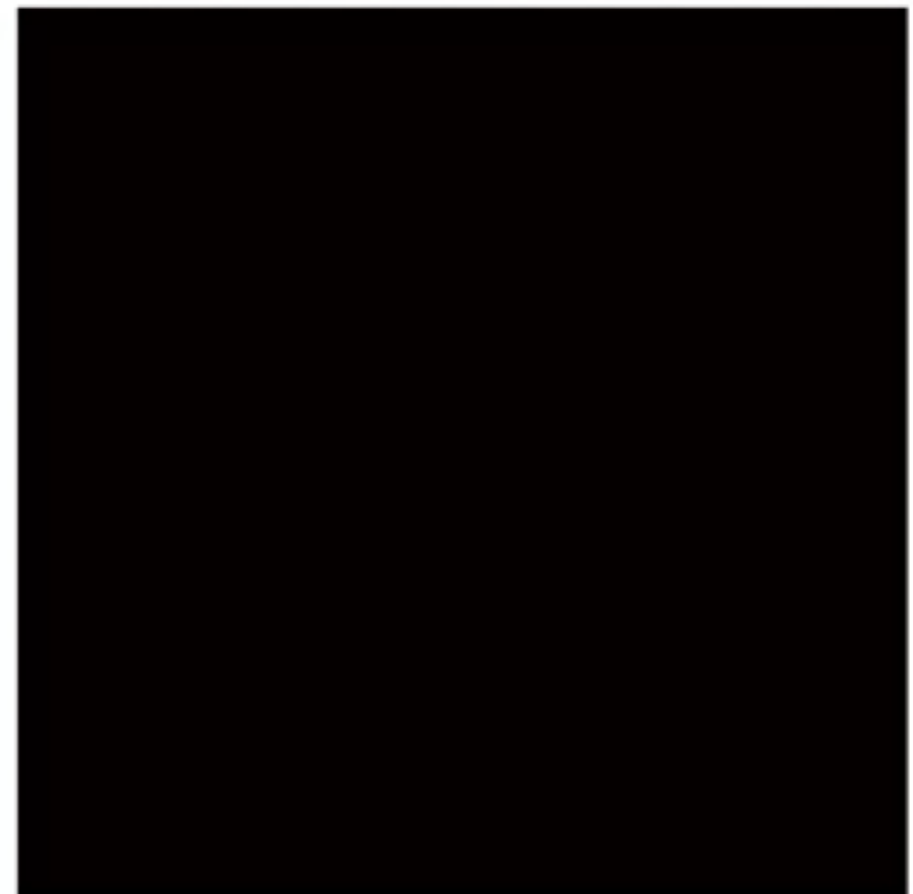
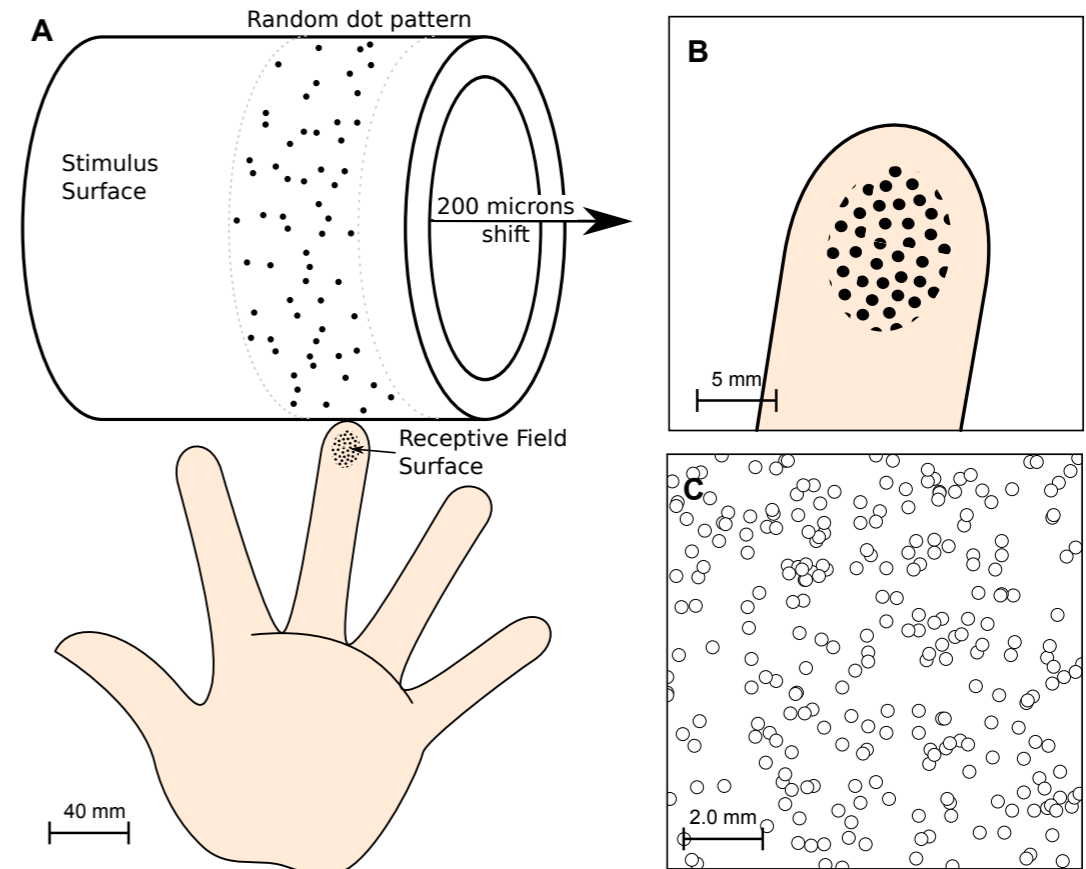
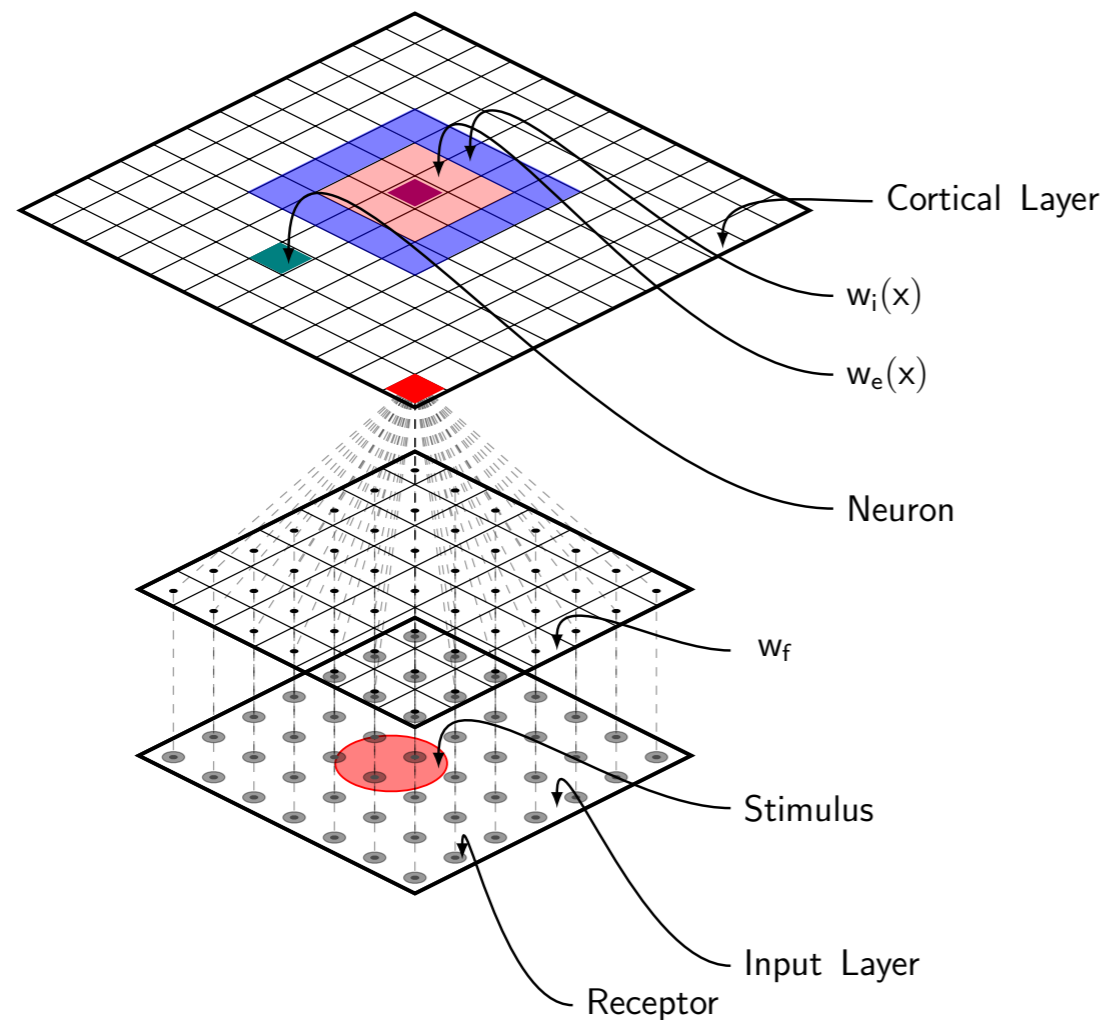

Decision making

(Topalidou et al, 2016)

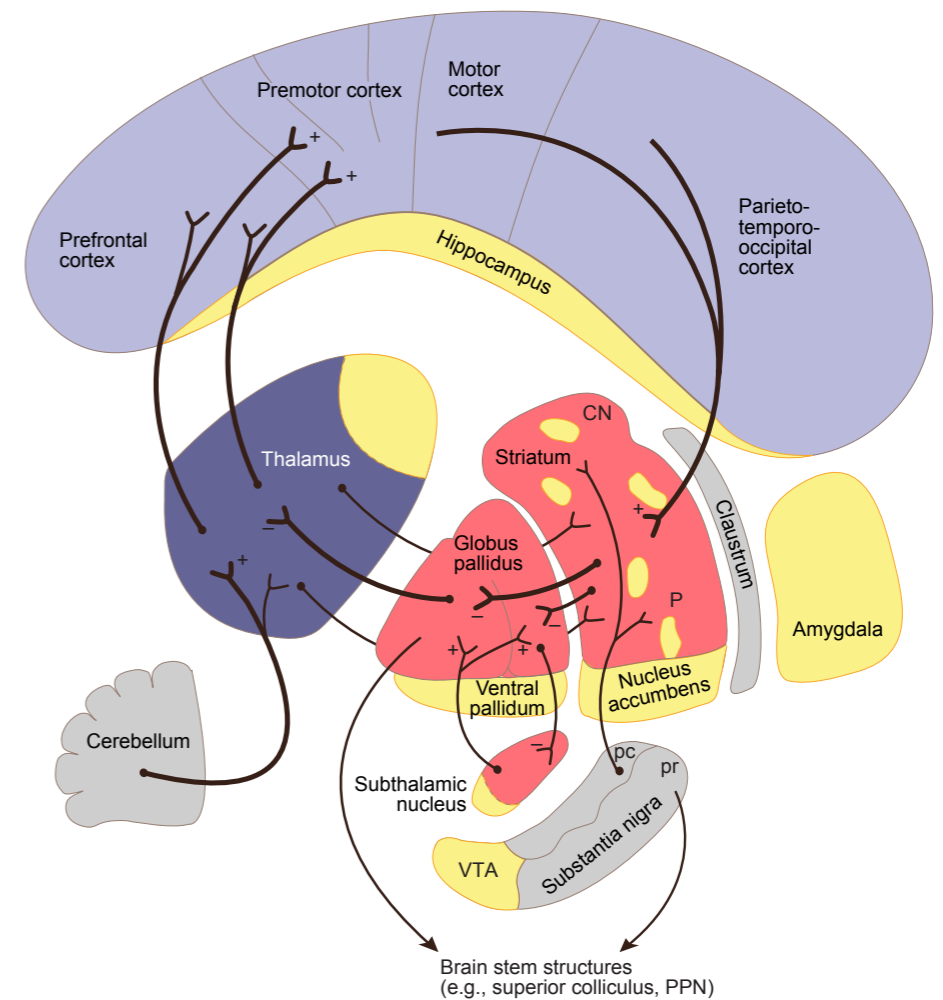
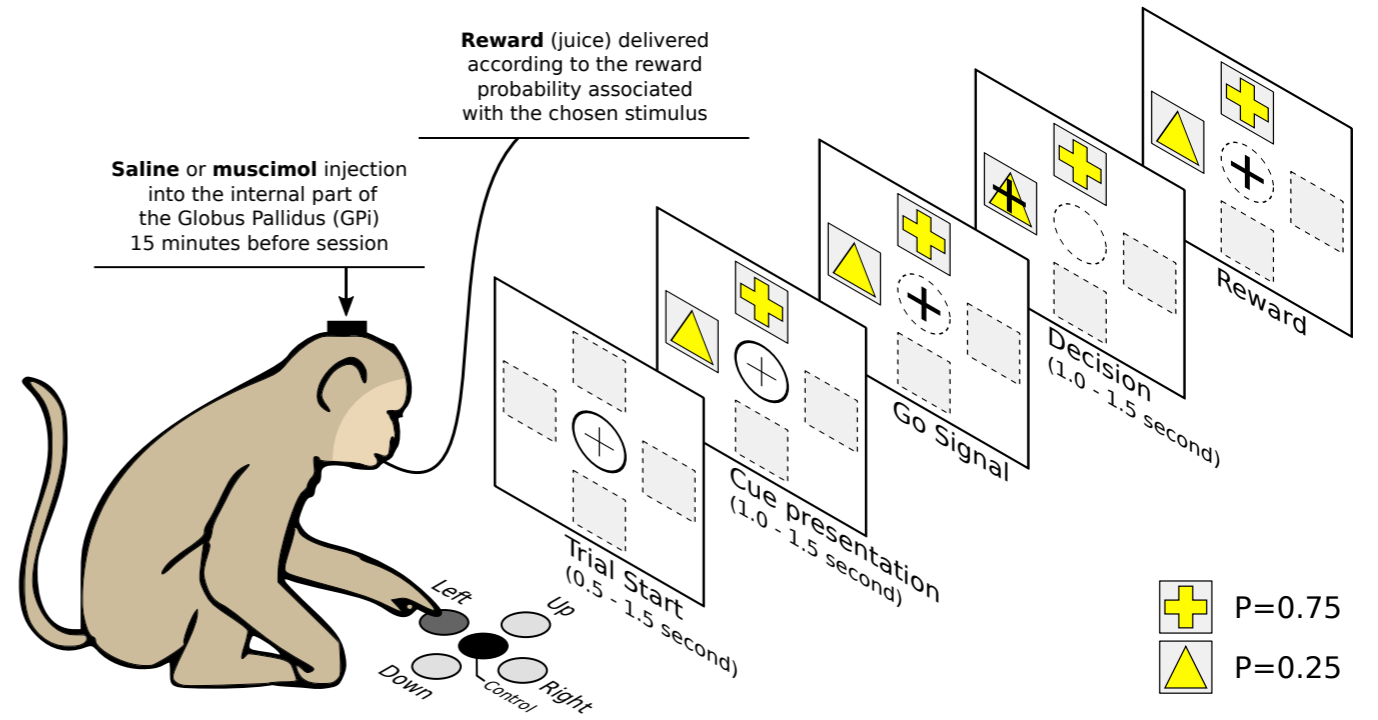
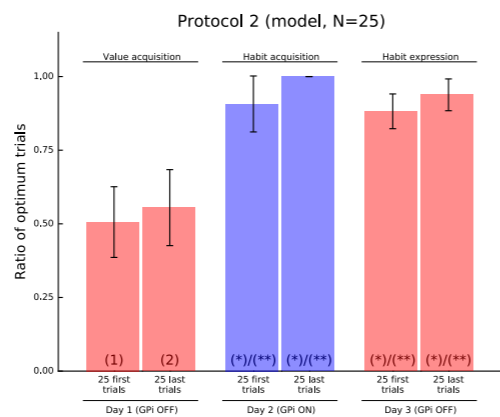
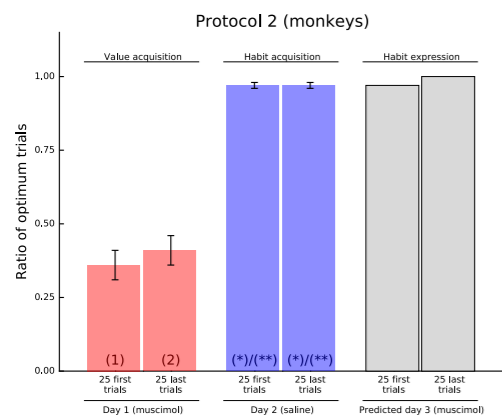
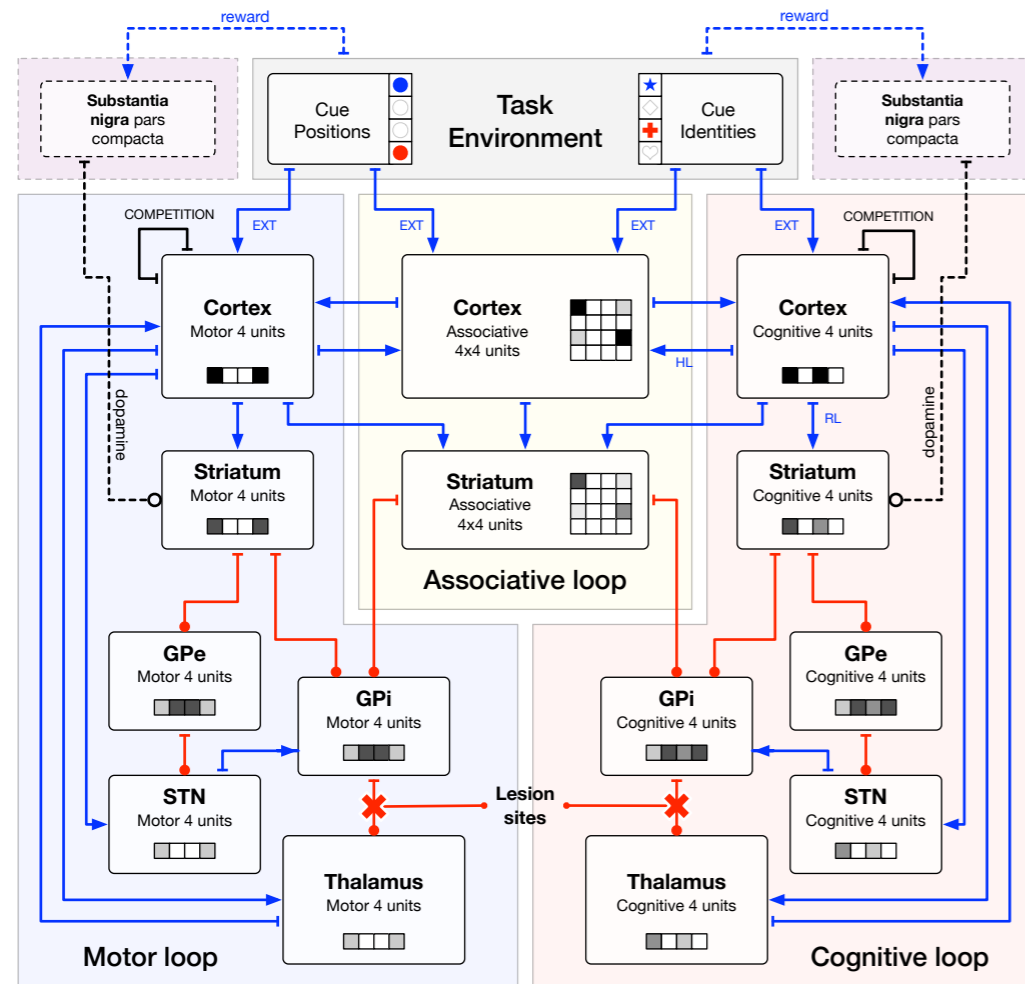

Numerical simulations

Clock-driven vs event-driven simulation

There are two families of algorithms for the simulation of neural networks:

- synchronous or clock-driven algorithms, in which all neurons are updated simultaneously at every tick of a clock
- asynchronous or event-driven algorithms, in which neurons are updated only when they receive or emit a spike

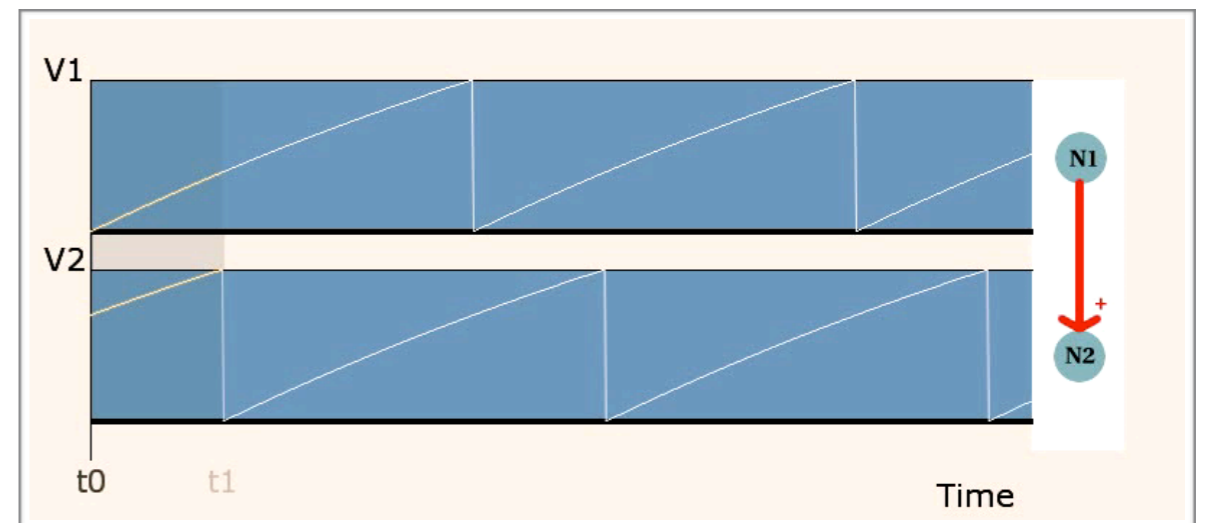
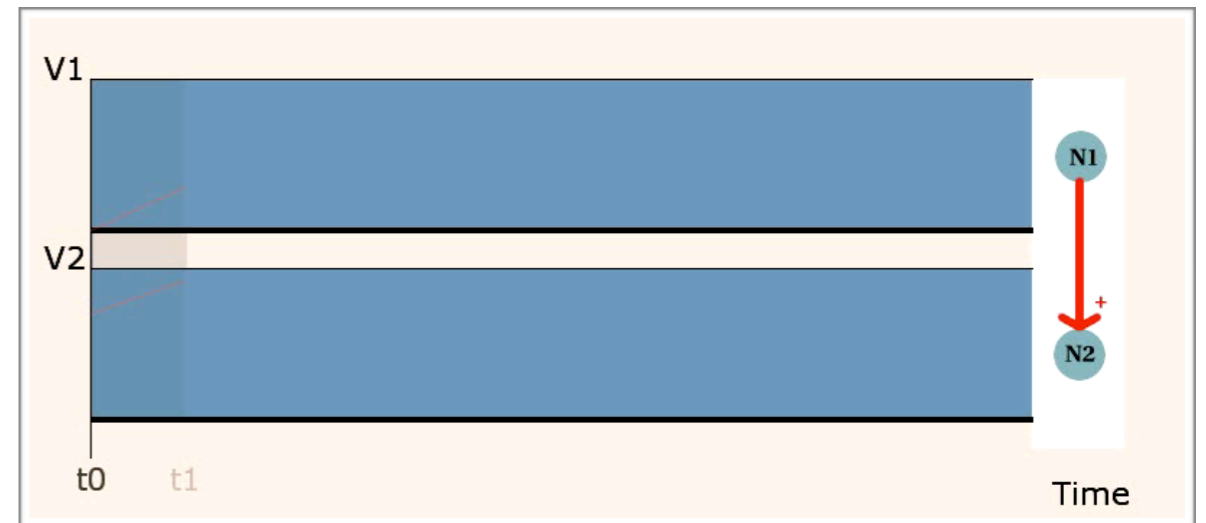

NEURON

www.neuron.yale.edu/neuron

NEURON is a simulation environment for modelling individual neurons and networks of neurons. It provides tools for conveniently building, managing, and using models in a way that is numerically sound and computationally efficient.

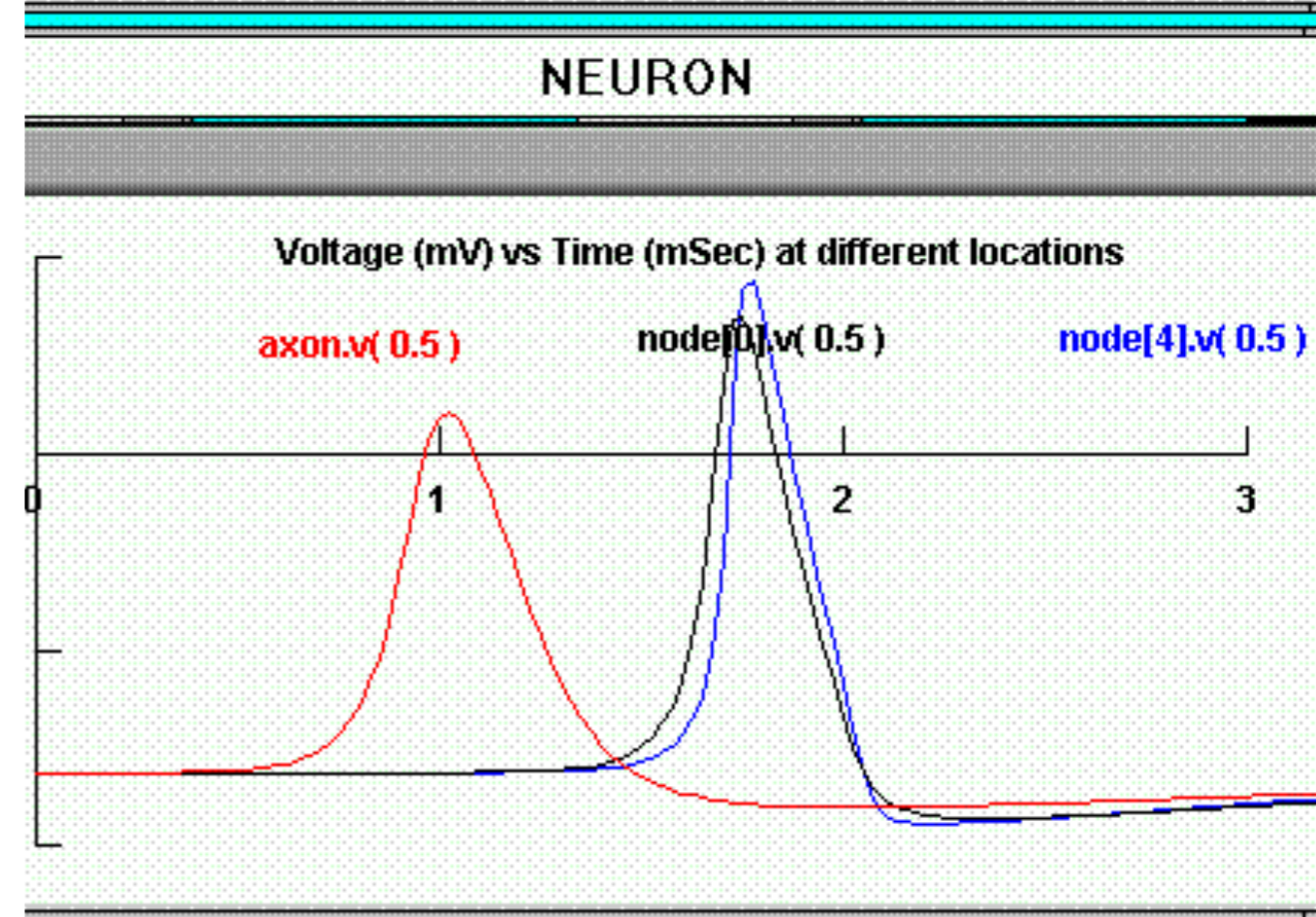
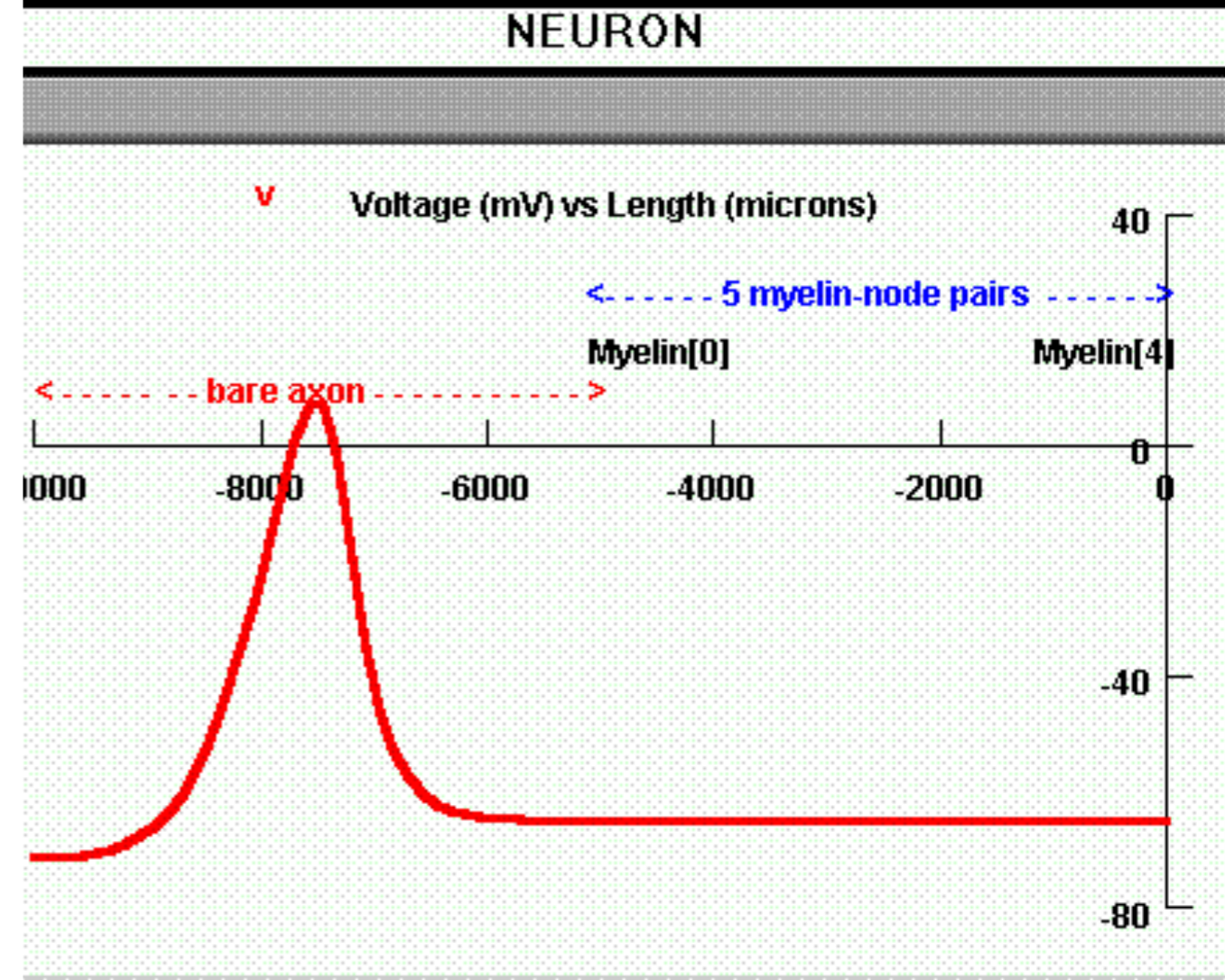

NEST simulator

www.nest-simulator.org

NEST is a simulator for spiking neural network models that focuses on the dynamics, size and structure of neural systems rather than on the exact morphology of individual neurons.

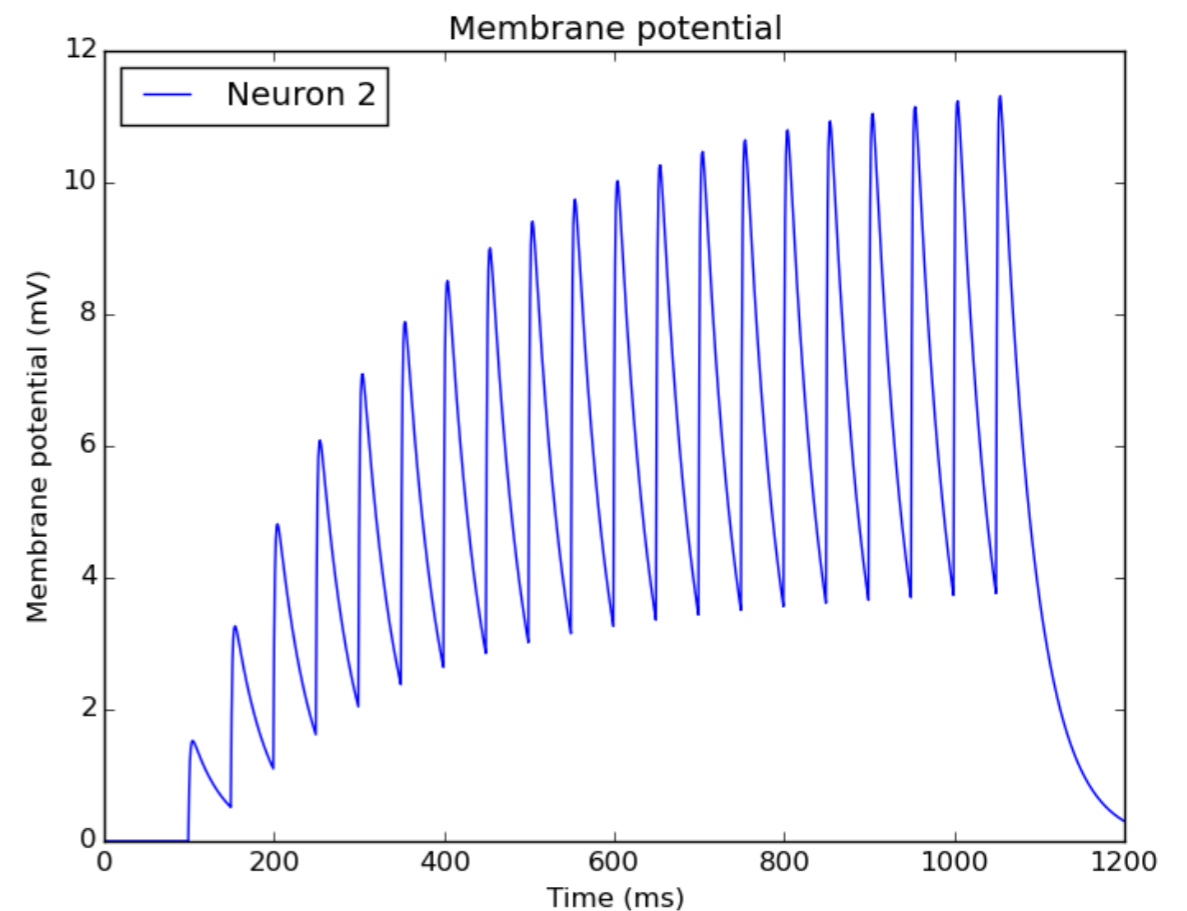
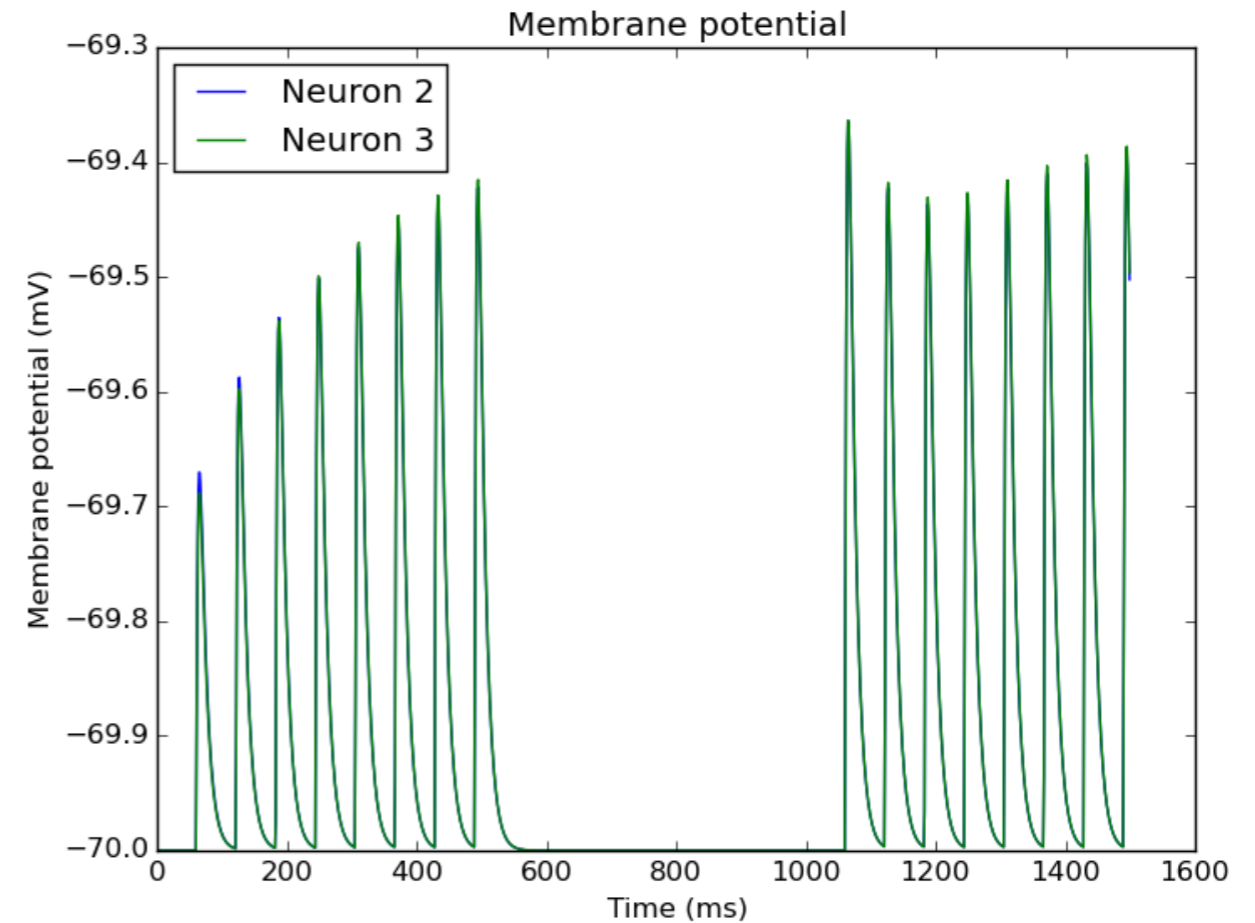

Brian simulator

briansimulator.org

Brian is a simulator for spiking neural networks available on almost all platforms. The motivation for this project is that a simulator should not only save the time of processors, but also the time of scientists.

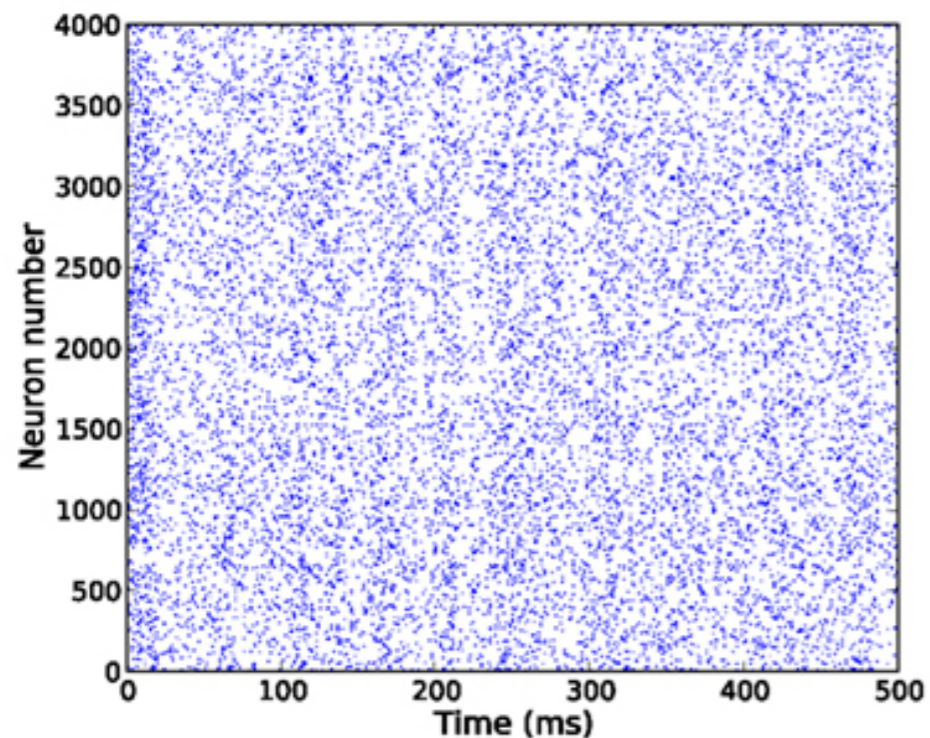

```
from brian import *
eqs = '''
dV/dt = (ge+gi-(V+49*mV))/(20*ms) : volt
dge/dt = -ge/(5*ms) : volt
dgi/dt = -gi/(10*ms) : volt
'''
P = NeuronGroup(4000, model=eqs,
                threshold=-50*mV, reset=-60*mV)
Pe = P.subgroup(3200)
Pi = P.subgroup(800)
Ce = Connection(Pe, P, 'ge')
Ci = Connection(Pi, P, 'gi')
Ce.connect_random(Pe, P, p=0.02,
                  weight=1.62*mV)
Ci.connect_random(Pi, P, p=0.02,
                  weight=-9*mV)
M = SpikeMonitor(P)
P.V = -60*mV+10*mV*rand(len(P))
run(.5*second)
raster_plot(M)
show()
```

Reproducible Science

Over the years, the Python language has become the preferred language for computational neuroscience.

PyNN is an interface that makes possible to write a simulation script once, using the Python programming language, and run it without modification on any supported simulator.

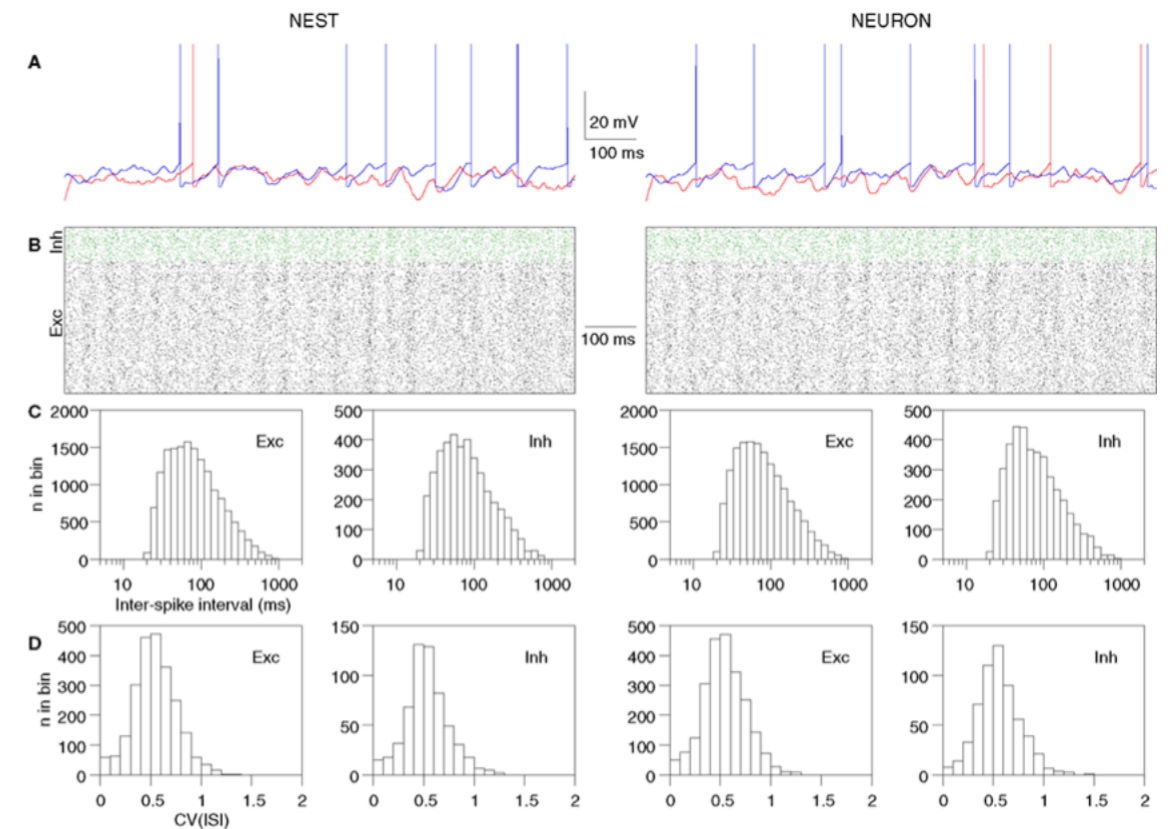

Beyond this short course

- D Purves, GJ Augustine GJ, D Fitzpatrick, et al. **Neuroscience**, 2001.
- P Dayan, L Abbott, **Theoretical Neuroscience**, MIT Press, 2005.
- W Gerstner, W Kistler, **Spiking Neuron Models**, Cambridge Univ. Press, 2002.
- C Koch, I Segev, **Methods in Neuronal Modeling**, MIT Press, 1998.
- M Arbib, **Handbook of Brain Theory and Neural Networks**, MIT Press, 1995.

