

# Near-colorings and Steinberg conjecture

André Raspaud

LaBRI  
Université Bordeaux I  
France

Department of Mathematics,  
Zhejiang Normal University,  
Jinhua, China  
October 13, 2011

## Proper $k$ -coloring

### Proper $k$ -coloring

Let  $G$  be a graph and  $k$  ( $k \geq 1$ ) an integer.

A proper  $k$ -coloring of  $G$  is a mapping  $\phi : V(G) \longrightarrow \{1, \dots, k\}$  such that:

- ▶ for every edge  $xy$ ,  $\phi(x) \neq \phi(y)$

In other words, a  $k$ -coloring of  $G$  is a partition  $V_1, V_2, \dots, V_k$  of  $V(G)$  such that  $V_i$  is an independent set for every  $i$ , i.e., the subgraph induced by  $V_i$  has maximum degree zero.

## $d$ -improper $k$ -coloring

Burr and Jacobson (1985), Cowen, Cowen, and Woodall (1986), Harary and Jones (1985).

### $d$ -improper $k$ -coloring

Let  $G$  be a graph and  $k, d$  ( $k, d \geq 1$ ) integers.

A  $d$ -improper  $k$ -coloring of  $G$  is a mapping  $\psi : V(G) \rightarrow \{1, \dots, k\}$  such that :

- ▶  $\forall i, 1 \leq i \leq k, G[i]$  has a maximum degree at most  $d$
- ▶  $G[i]$  is the subgraph induced by color  $i$ .

Every vertex  $v$  has at most  $d$  neighbors receiving the same color as  $v$ .

- ▶ a  $d$ -improper  $k$ -coloring :  $(d, \dots, d)$ -coloring
- ▶ a  $(0, 0, 0, 0)$ -coloring is a proper 4-coloring.
- ▶ a  $(2, 2, 2)$ -coloring is a 2-improper 3-coloring.

$d$ -improper  $k$ -coloring

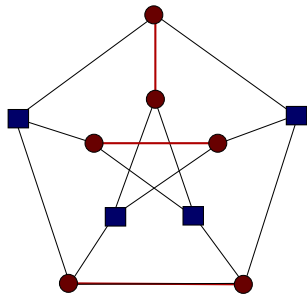

(1, 1)-coloring

## Known results

### Appel and Haken, 1977

- ▶ Every planar graph is  $(0, 0, 0, 0)$ -colorable.

### Cowen, Cowen, and Woodall, 1986

- ▶ Every planar graph is 2-improperly 3-colorable, i.e.  $(2, 2, 2)$ -colorable.

### Xu, 2009

Every plane graph with neither adjacent triangles nor 5-cycles is  $(1, 1, 1)$ -colorable.

### Corollary

*Every plane graph with neither 4-cycles nor 5-cycles is  $(1, 1, 1)$ -colorable.*

## Known results-Choosability

### Definition

A graph  $G$  is  $d$ -improper  $m$ -choosable, or simply  $(m, d)^*$ -choosable, if for every list assignment  $L$ , where  $|L(v)| \geq m$  for every  $v \in V(G)$ , there exists an  $L$ -colouring of  $G$  such that each vertex of  $G$  has at most  $d$  neighbours coloured with the same colour as itself.

Eaton and Hull (1999), Škrekovski (1999)

- ▶ Every planar graph is 2-improper 3-choosable:  $(3, 2)^*$ -choosable.

If a graph  $G$  is 2-improper 3-choosable then it is  $(2, 2, 2)$ -colorable.

Škrekovski proved that for every  $k$ , there are planar graphs which are not  $k$ -improper 2-colorable.

## Known results

### Cushing and Kierstead (2009)

Every planar graph is 1-improper 4-choosable  $((4, 1)^*$ -choosable).

### Dong and Xu 2009

Let  $G$  be a plane graph without any cycles of length in  $\{4, 8\}$ , then  $G$  is  $(3, 1)^*$ -choosable.

### Question (Xu and Zhang, 2007)

*Is-it true that every planar graph without adjacent triangle is  $(3, 1)^*$ -choosable.*

**A weaker question:** Is-it true that every planar graph without adjacent triangle is  $(1, 1, 1)$ -colorable?

### Definition-Maximum average degree

$$\text{Mad}(G) = \max \left\{ \frac{2 \cdot |E(H)|}{|V(H)|}, H \subseteq G \right\}.$$



### Definition-Maximum average degree

$$\text{Mad}(G) = \max \left\{ \frac{2 \cdot |E(H)|}{|V(H)|}, H \subseteq G \right\}.$$

In 1995, Jensen and Toft showed that there is a polynomial algorithm to compute  $\text{Mad}(G)$  for a given graph  $G$ .

T. R. Jensen and B. Toft, Choosability versus chromaticity, Geombinatorics 5(1995), 45-64.

if  $G$  is a planar graph with girth  $g$ , then  $\text{Mad}(G) < \frac{2g}{g-2}$ .

### Havet and Sereni, 2006

- ▶ For every  $k \geq 0$ , every graph  $G$  with  $Mad(G) < \frac{4k+4}{k+2}$  is  $k$ -improperly 2-colorable (in fact  $k$ -improperly 2-choosable), i.e.  $(k, k)$ -colorable
- ▶  $k = 1$   $Mad(G) < \frac{8}{3}$  :  $(1, 1)$ -colorable (planar,  $g = 8$ ).
- ▶  $k = 2$   $Mad(G) < 3$  :  $(2, 2)$ -colorable (planar,  $g = 6$ ).

A more general result:

### Theorem (Havet and Sereni)

*For every  $l \geq 2$  and every  $k \geq 0$ , all graphs of maximum average degree less than  $\frac{l(l+2k)}{l+k}$  are  $k$ -improper  $l$ -choosable.*

it implies  $(k, \dots, k)$ -colorable.

## $(d_1, d_2, \dots, d_k)$ -coloring

### $(d_1, d_2, \dots, d_k)$ -coloring

A graph  $G$  is  $(d_1, d_2, \dots, d_k)$ -colorable if and only if:

- ▶ it exists a partition of  $V$ :  $V = V_1 \cup V_2 \cup \dots \cup V_k$  such that  $\forall i \in [1, k]$ ,  $\Delta(G[V_i]) \leq d_i$

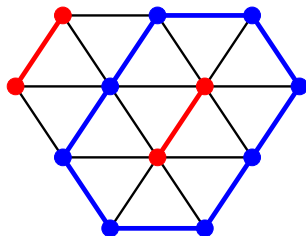

$(2, 1)$ -coloring

$(d_1, d_2, \dots, d_k)$ -coloring

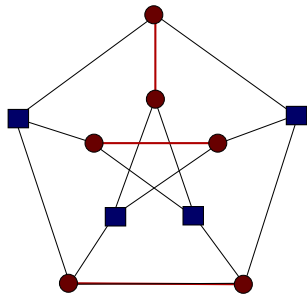

$(1, 0)$ -coloring

## $(1, 0)$ -colorable

Theorem (Glebov and Zambalaeva, 2007)

*Every planar graph is  $(1, 0)$ -colorable if  $g(G) \geq 16$ .*

Theorem (Borodin and Ivanova, 2009)

*Every graph is  $(1, 0)$ -colorable if  $Mad(G) < \frac{7}{3}$*

This implies: A planar graph is  $(1, 0)$ -colorable if  $g(G) \geq 14$

Sketch of proof: every graph is  $(1, 0)$ -colorable if  $Mad(G) < \frac{7}{3}$

New technique first introduced by Borodin, Ivanova and Kostochka in 2006.

Let  $G = (V, E)$  be a minimum counterexample to the theorem.

- ▶  $\delta(G) \geq 2$  and  $G$  is connected.
- ▶  $\frac{\sum_{v \in V} d(v)}{|V|} = \frac{2|E|}{|V|} < \frac{7}{3} \implies 3 \sum_{v \in V} d(v) < 7|V|$   
 $\implies \sum_{v \in V} (6d(v) - 14) < 0$
- ▶ We give a charge  $\forall v \in V \mu(v) = 6d(v) - 14$   
 $d(v) = 2 \implies \mu(v) = -2, d(v) = 3 \implies \mu(v) = 4$  etc.
- ▶ The total charge is negative, we will redistribute the charges in such a way that the total charge will be non negative. The sum of charges does not change, this is a CONTRADICTION.

Sketch of proof: every graph is  $(1, 0)$ -colorable if  $Mad(G) < \frac{7}{3}$

Let  $G = (V, E)$  be a minimum counterexample to the theorem.

**Lemme**

*$G$  does not contain no 2-vertex adjacent to two 2-vertices.*

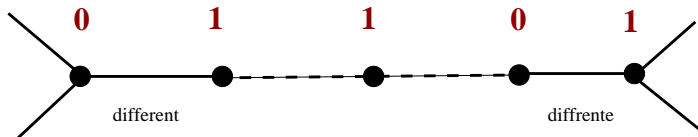
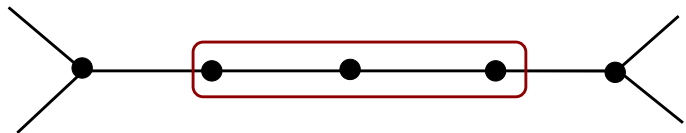

Sketch of proof: every graph is  $(1, 0)$ -colorable if  $Mad(G) < \frac{7}{3}$

### Lemme

$G$  does not contain a  $(2, 2, 2)$ -vertex.

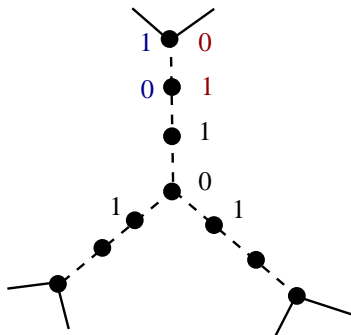
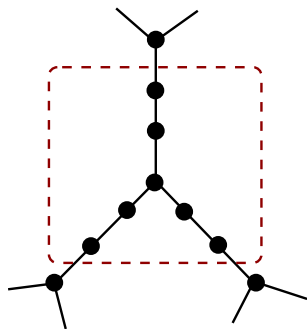



Sketch of proof: every graph is  $(1, 0)$ -colorable if  $Mad(G) < \frac{7}{3}$

Recall:  $d(v) = 2 \implies \mu(v) = -2$ ,  $d(v) = 3 \implies \mu(v) = 4$

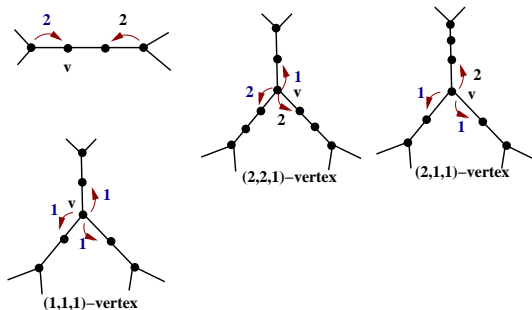

- ▶ 2-vertex  $\implies \mu^*(v) = 0$
- ▶ (2, 2, 1)-vertex  $\implies \mu^*(v) = -1$
- ▶ (2, 1, 1)-vertex  $\implies \mu^*(v) = 0$
- ▶ (1, 1, 1)-vertex  $\implies \mu^*(v) = 1$

Sketch of proof: every graph is  $(1, 0)$ -colorable if  $Mad(G) < \frac{7}{3}$

## Feeding Area

A maximal subgraph consisting of  $(2, 2, 1)$ -,  $(2, 1, 1)$ -,  $(1, 1, 1)$ -vertices mutually accessible from each other along 1-paths, and of those 2-vertices adjacent to vertices of FA only.

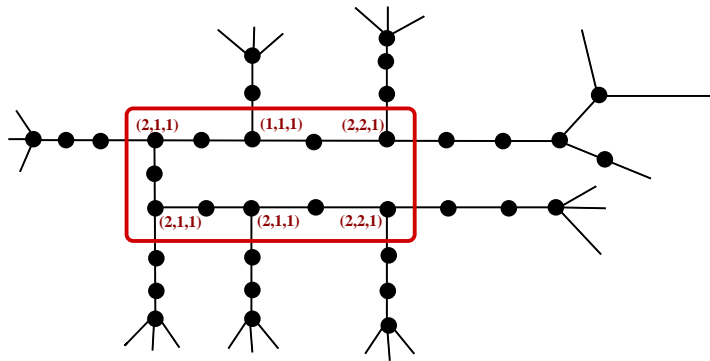

Sketch of proof: every graph is  $(1, 0)$ -colorable if  $Mad(G) < \frac{7}{3}$

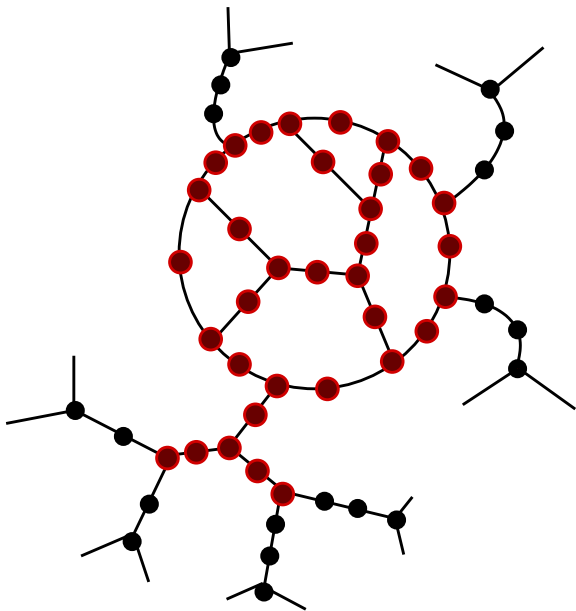

Sketch of proof: every graph is  $(1, 0)$ -colorable if  $Mad(G) < \frac{7}{3}$

## Soft component

A feeding area FA such that all edges from FA to  $G \setminus FA$  belongs to 2-paths

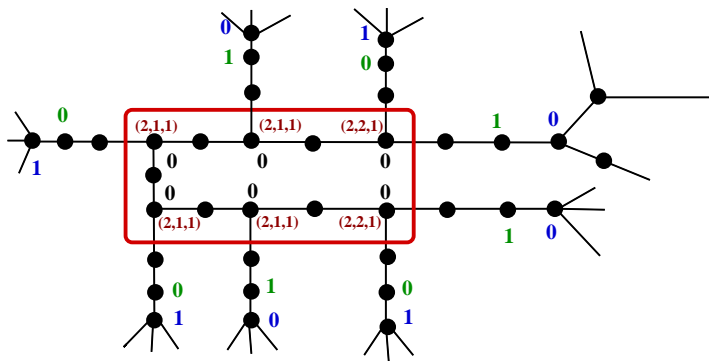

Sketch of proof: every graph is  $(1, 0)$ -colorable if  $Mad(G) < \frac{7}{3}$

## Soft component

A feeding area FA such that all edges from FA to  $G \setminus FA$  belongs to 2-paths

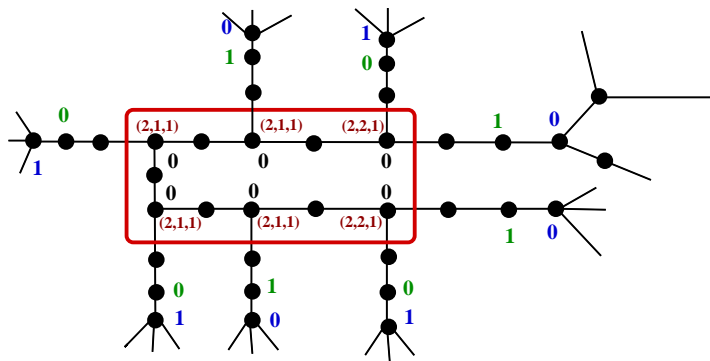

## Lemma

$G$  has no soft component.

Sketch of proof: every graph is  $(1, 0)$ -colorable if  $Mad(G) < \frac{7}{3}$

A *tough* vertex is a 3-vertex incident with at least one 0-path.

No soft component implies:

### Corollary

*For each feeding area FA, there exists a  $xz$  1-path such that  $x \in FA$  and  $z \notin FA$  where  $z$  is tough or  $d(z) \geq 4$*

### The key Lemma

Let  $n_{221}$  be the number of  $(2, 2, 1)$ -vertices in a feeding area FA,  $n_{111}$  be the number of  $(1, 1, 1)$ -vertices of FA,  $b$  be the number of 1-path going from FA to tough or  $\geq 4$ -vertices. Then  $n_{221} \leq n_{111} + b$

### Rules of discharging

- R1 Every 2-vertex that belong to a 1-path gets 1 from its ends, each 2-vertex that belongs to a 2-path gets charge 2 from the neighbor vertex of degree greater than 2.
- R2 Each  $(2, 2, 1)$ -vertex gets 1 from its feeding area, each feeding area gets 1 from each of its  $(1, 1, 1)$ -vertex and along each 1-path that goes to a tough vertex or a  $\geq 4$ -vertex.

Sketch of proof: every graph is  $(1, 0)$ -colorable if  $Mad(G) < \frac{7}{3}$

- ▶ After applying R1 and R2, the new charge of a 2-vertex  $v$  is  $\mu^*(v) = 0$ . By the Key lemma the total charge of each feeding area is non negative. Each tough vertex has also a nonnegative charge.
- ▶ If  $d(v) \geq 4$ .  $v$  gives at most 2 along each incident edge by R1 and R2, then:

$$\mu^*(v) \geq 6d(v) - 14 - 2d(v) = 4d(v) - 14 > 0$$

The total charge is non negative: a contradiction.

# Improvement

Theorem (Borodin and Kostochka, 2010)

Every graph  $G$  with  $\text{Mad}(G) \leq \frac{12}{5}$  is  $(1,0)$ -colorable and the restriction on  $\text{Mad}(G)$  is sharp.

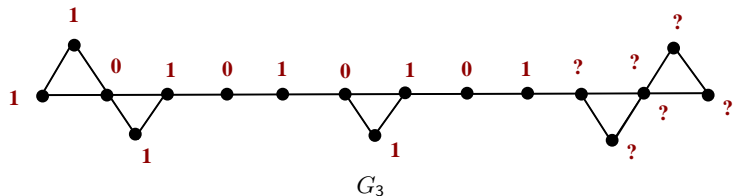



## Improvement

Theorem (Borodin and Kostochka, 2010)

Every graph  $G$  with  $\text{Mad}(G) \leq \frac{12}{5}$  is  $(1,0)$ -colorable and the restriction on  $\text{Mad}(G)$  is sharp.

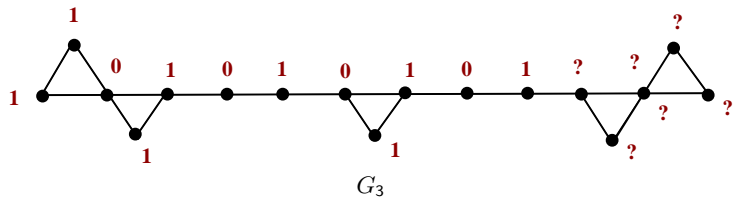

$$\text{Mad}(G_p) = \frac{2|E(G_p)|}{|V(G_p)|} = \frac{12p + 6}{5p + 2} = \frac{12}{5} + \frac{6}{5(5p + 2)}$$

# Steinberg Conjecture

## Conjecture (Steinberg, 1976)

*Every planar graph without 4 and 5-cycles is 3-colorable ((0, 0, 0)-colorable)*

**Erdős' relaxation '91:** Determine the smallest value of  $k$ , if it exists, such that every planar graph without cycles of length from 4 to  $k$  is 3-colorable.

- ▶  $k \leq 11$  Abbott and Zhou ('91)
- ▶  $k \leq 10$  Borodin ('96)
- ▶  $k \leq 9$  Borodin ('96) and Sanders and Zhao ('95)
- ▶  $k \leq 8$  Salavatipour (2002)
- ▶  $k \leq 7$  Borodin et al. (2005)

## Steinberg Conjecture

Let  $\mathcal{F}$  be the family of planar graphs without cycles of length 4 and 5.  
Can we prove that every graph in  $\mathcal{F}$  is:

- ▶  $(1, 0, 0)$ -colorable?

## Steinberg Conjecture

Let  $\mathcal{F}$  be the family of planar graphs without cycles of length 4 and 5.

Can we prove that every graph in  $\mathcal{F}$  is:

- ▶  $(1, 0, 0)$ -colorable?
- ▶  $(1, 1, 0)$ -colorable?

# Steinberg Conjecture

Let  $\mathcal{F}$  be the family of planar graphs without cycles of length 4 and 5.

Can we prove that every graph in  $\mathcal{F}$  is:

- ▶  $(1, 0, 0)$ -colorable?
- ▶  $(1, 1, 0)$ -colorable?
- ▶  $(1, 1, 1)$ -colorable (Xu, 2009)

Every graph in  $\mathcal{F}$  is  $(1, 1, 1)$ -colorable

By Euler's Formula :

$$|V| - |E| + |F| = 2$$

and

$$\sum_{v \in V} d(v) = 2|E| = \sum_{f \in F} r(f)$$

,

and

$$\omega(v) = 2d(v) - 6 \text{ and } \omega(f) = r(f) - 6.$$

we have:

$$\sum_{v \in V} \omega(v) + \sum_{f \in F} \omega(f) = -12 < 0.$$

$$\text{If } r(f) = 3 \text{ then } \omega(f) = -3$$

Every graph in  $\mathcal{F}$  is  $(1, 1, 1)$ -colorable

Let  $G$  be a minimum counterexample.

1.  $\delta(G) \geq 3$
2. no two 3-vertices adjacent
3. no 3-vertex adjacent to two adjacent 4-vertices

Every graph in  $\mathcal{F}$  is  $(1, 1, 1)$ -colorable

Discharging rules:

**Rule 1**  $v$  s.t.  $d(v) = 4$  gives 1 to an incidente 3-face.

**Rule 2** a  $5^+$ -vertex gives 2 to an incidente 3-face.

Remember : a 3-face needs 3.



Every graph in  $\mathcal{F}$  is  $(1, 1, 1)$ -colorable

### Final balance

We have to feed the 3-face.

- ▶  $(3, 4, 5^+)$ -face gets  $2+1=3$
- ▶  $(3, 5^+, 5^+)$ -face gets  $2+2=4$
- ▶  $(4^+, 4^+, 4^+)$ -face gets at least  $1+1+1=3$

We have after discharging  $\omega^*(f) \geq 0$  for any face of  $G$

Every graph in  $\mathcal{F}$  is  $(1, 1, 1)$ -colorable

### Final balance

Let  $v$  be a vertex of  $G$ ,

- ▶ if  $v$  is a 3-vertex,  $v$  gives nothing then in this case  $\omega^*(v) = \omega(v) = 0$
- ▶ if  $v$  is a 4-vertex,  $v$  can be incident to at most 2 3-faces. Hence  $\omega^*(v) \geq 2 - 2 = 0$
- ▶ if  $v$  is a  $5^+$ -vertex, it can be incident to at most  $\lfloor \frac{d(v)}{2} \rfloor$  3-faces. Hence:  
$$\omega^*(v) \geq 2d(v) - 6 - 2\lfloor \frac{d(v)}{2} \rfloor \geq 0$$

$$0 \leq \sum_{v \in V} \omega^*(v) + \sum_{f \in F} \omega^*(f) = \sum_{v \in V} \omega(v) + \sum_{f \in F} \omega(f) = -12 < 0.$$

A CONTRADICTION.

Every graph in  $\mathcal{F}$  is  $(1, 1, 1)$ -colorable

### Final balance

Let  $v$  be a vertex of  $G$ ,

- ▶ if  $v$  is a 3-vertex,  $v$  gives nothing then in this case  $\omega^*(v) = \omega(v) = 0$
- ▶ if  $v$  is a 4-vertex,  $v$  can be incident to at most 2 3-faces. Hence  $\omega^*(v) \geq 2 - 2 = 0$
- ▶ if  $v$  is a  $5^+$ -vertex, it can be incident to at most  $\lfloor \frac{d(v)}{2} \rfloor$  3-faces. Hence:  
 $\omega^*(v) \geq 2d(v) - 6 - 2\lfloor \frac{d(v)}{2} \rfloor \geq 0$

$$0 \leq \sum_{v \in V} \omega^*(v) + \sum_{f \in F} \omega^*(f) = \sum_{v \in V} \omega(v) + \sum_{f \in F} \omega(f) = -12 < 0.$$

A CONTRADICTION.

### Remark

We proved that any  $G \in \mathcal{F}$  is  $(3, 1)^*$ -choosable.

# Steinberg Conjecture

$(2, 0, 0)$ -colorable?

# Steinberg Conjecture

$(2, 0, 0)$ -colorable?

Theorem (Chang, Havet, Montassier, R. 2011)

*Every graph of  $\mathcal{F}$  is  $(2, 1, 0)$ -colorable.*

## $(2, 1, 0)$ -colorability of $\mathcal{F}$

By Euler's Formula :

$$|V| - |E| + |F| = 2$$

and

$$\sum_{v \in V} d(v) = 2|E| = \sum_{f \in F} r(f)$$

, and

$$\omega(v) = 2d(v) - 6 \text{ and } \omega(f) = r(f) - 6.$$

we have:

$$\sum_{v \in V} \omega(v) + \sum_{f \in F} \omega(f) = -12 < 0.$$

If  $r(f) = 3$  then  $\omega(f) = -3$

## $(2, 1, 0)$ -colorability of $\mathcal{F}$

Reducible configurations for  $(2, 1, 0)$ -coloring.

(C1)  $G$  contains no  $2^-$ -vertices.

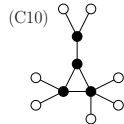
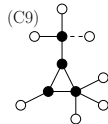
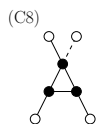
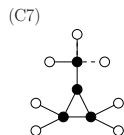
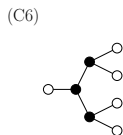
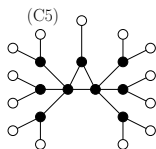
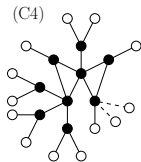
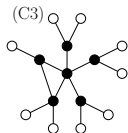
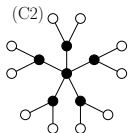

## $(2, 1, 0)$ -colorability of $\mathcal{F}$

The discharging rules are as follows:

- R1.** Every 4-vertex gives  $\frac{1}{2}$  to each pendent 3-face.
- R2.** Every  $5^+$ -vertex gives 1 to each pendent 3-face.
- R3.** Every 4-vertex gives 1 to each incident 3-face.
- R4.** Every non-light 5-vertex gives 2 to each incident poor  $(3, 5, 5)$ -face.
- R5.** Every 5-vertex gives  $\frac{3}{2}$  to each incident non-poor  $(3, 5, 5)$ -face or  $(3, 4, 5)$ -face.
- R6.** Every 5-vertex gives 1 to each other incident 3-face.
- R7.** Every  $6^+$ -vertex gives 2 to each incident 3-face.

$$0 \leq \sum_{v \in V} \omega^*(v) + \sum_{f \in F} \omega^*(f) = \sum_{v \in V} \omega(v) + \sum_{f \in F} \omega(f) = -12 < 0.$$



## Questions : summary

**Can we prove: Any planar graph  $G$  without  $C_4$  and  $C_5$  is :**

$(0,0,0)$ -colorable? Steinberg Conjecture.

## Questions : summary

**Can we prove: Any planar graph  $G$  without  $C_4$  and  $C_5$  is :**

$(0, 0, 0)$ -colorable? Steinberg Conjecture.

$(1, 0, 0)$ -colorable?

## Questions : summary

**Can we prove: Any planar graph  $G$  without  $C_4$  and  $C_5$  is :**

(0,0,0)-colorable? Steinberg Conjecture.

(1,0,0)-colorable?

(1,1,0)-colorable?

## Questions : summary

**Can we prove: Any planar graph  $G$  without  $C_4$  and  $C_5$  is :**

(0, 0, 0)-colorable? Steinberg Conjecture.

(1, 0, 0)-colorable?

(1, 1, 0)-colorable?

(1, 1, 1)-colorable? Result of B. Xu

## Questions : summary

**Can we prove: Any planar graph  $G$  without  $C_4$  and  $C_5$  is :**

(0, 0, 0)-colorable? Steinberg Conjecture.

(1, 0, 0)-colorable?

(1, 1, 0)-colorable?

(1, 1, 1)-colorable? Result of B. Xu

(2, 0, 0)-colorable?

## Questions : summary

**Can we prove: Any planar graph  $G$  without  $C_4$  and  $C_5$  is :**

(0,0,0)-colorable? Steinberg Conjecture.

(1,0,0)-colorable?

(1,1,0)-colorable?

(1,1,1)-colorable? Result of B. Xu

(2,0,0)-colorable?

(2,1,0)-colorable?

Yes

## Questions : summary

**Can we prove: Any planar graph  $G$  without  $C_4$  and  $C_5$  is :**

(0,0,0)-colorable? Steinberg Conjecture.

(1,0,0)-colorable?

(1,1,0)-colorable?

(1,1,1)-colorable? Result of B. Xu

(2,0,0)-colorable?

(2,1,0)-colorable?

Yes

(3,0,0)-colorable?

## Questions : summary

**Can we prove: Any planar graph  $G$  without  $C_4$  and  $C_5$  is :**

(0, 0, 0)-colorable? Steinberg Conjecture.

(1, 0, 0)-colorable?

(1, 1, 0)-colorable?

(1, 1, 1)-colorable? Result of B. Xu

(2, 0, 0)-colorable?

(2, 1, 0)-colorable?

Yes

(3, 0, 0)-colorable?

(4, 0, 0)-colorable?



## Questions : summary

Can we prove: Any planar graph  $G$  without  $C_4$  and  $C_5$  is :

(0, 0, 0)-colorable? Steinberg Conjecture.

(1, 0, 0)-colorable?

(1, 1, 0)-colorable?

(1, 1, 1)-colorable? Result of B. Xu

(2, 0, 0)-colorable?

(2, 1, 0)-colorable?

Yes

(3, 0, 0)-colorable?

(4, 0, 0)-colorable?

YES

Thank you for your attention!