

# Combinatorial Games on Graphs

Éric SOPENA

LaBRI, Bordeaux University

France

6TH POLISH COMBINATORIAL CONFERENCE

September 19-23, 2016

Będlewo, Poland

# Let's first play...

---

Take your favorite graph, e.g. Petersen graph.

On her turn, each player chooses a vertex and deletes its closed neighbourhood...

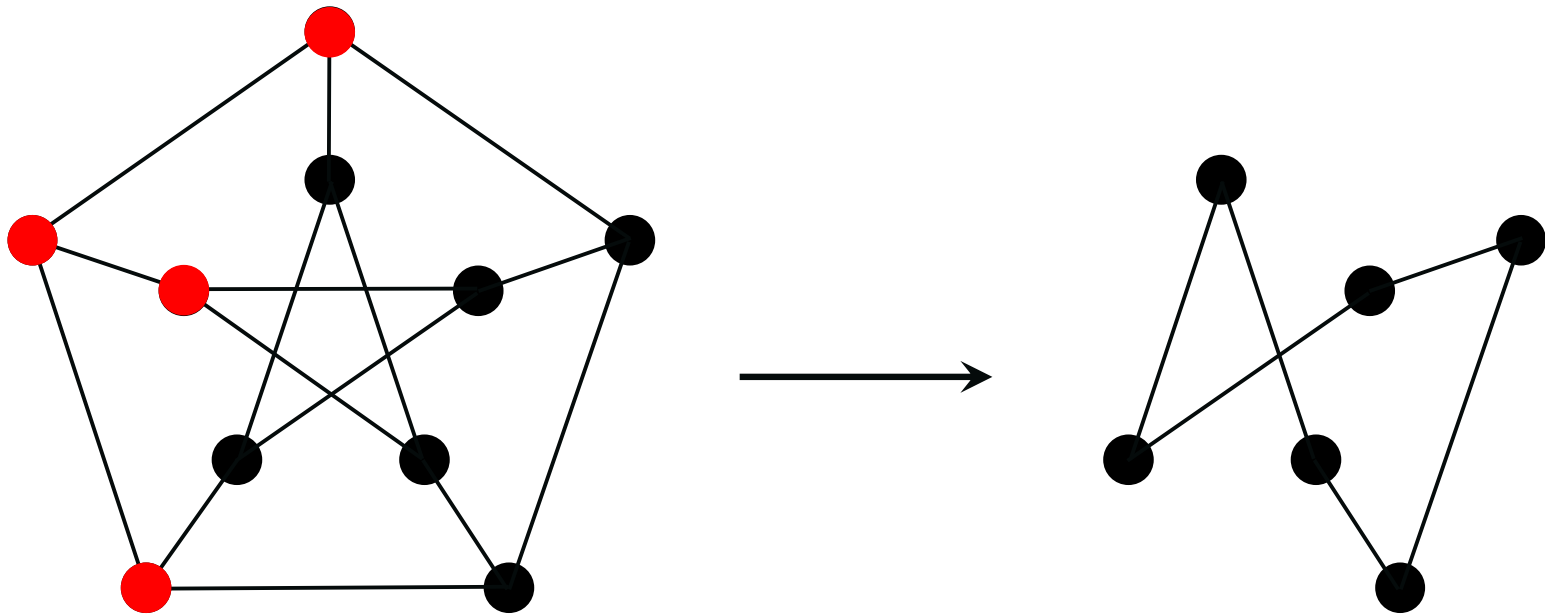

The first player **unable to move** **looses** the game...

# Let's first play...

---

Take your favorite graph, e.g. Petersen graph.

On her turn, each player chooses a vertex and deletes its closed neighbourhood...

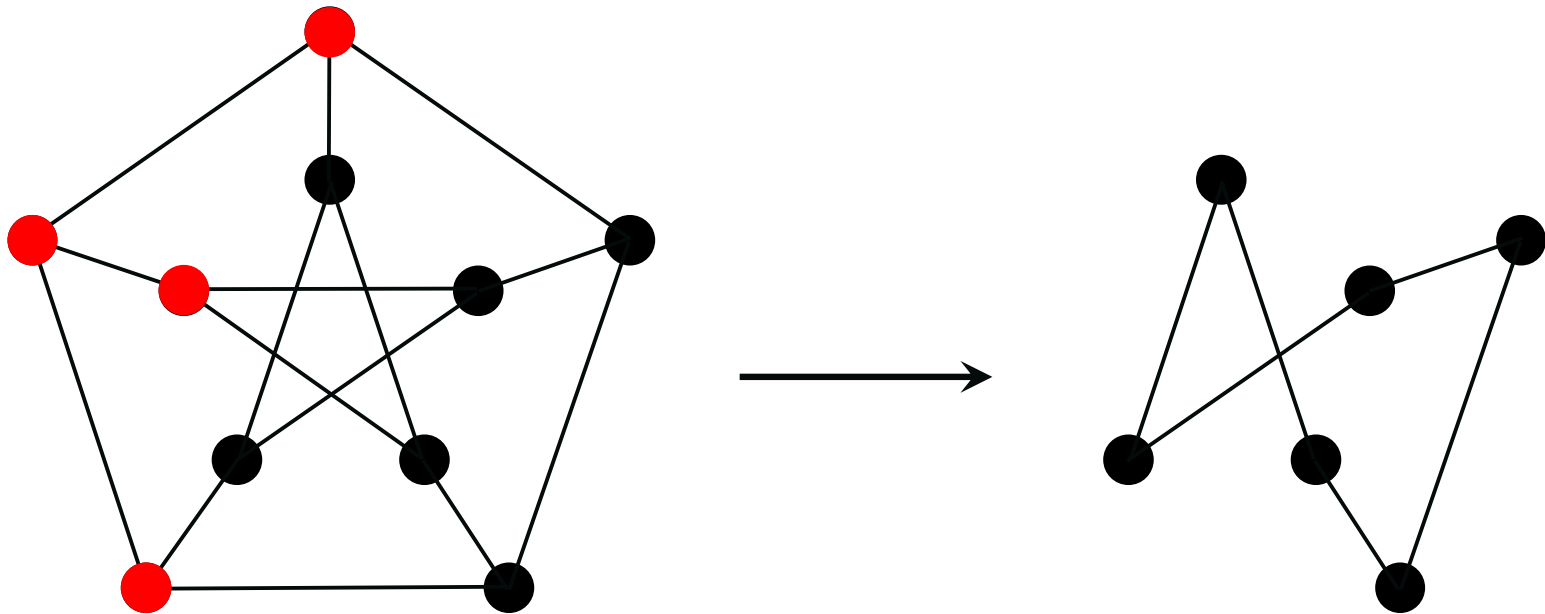

Would you prefer to be the **first player**? the **second player**?

# Let's first play...

---

Take your favorite graph, e.g. Petersen graph.

On her turn, each player chooses a vertex and deletes its closed neighbourhood...

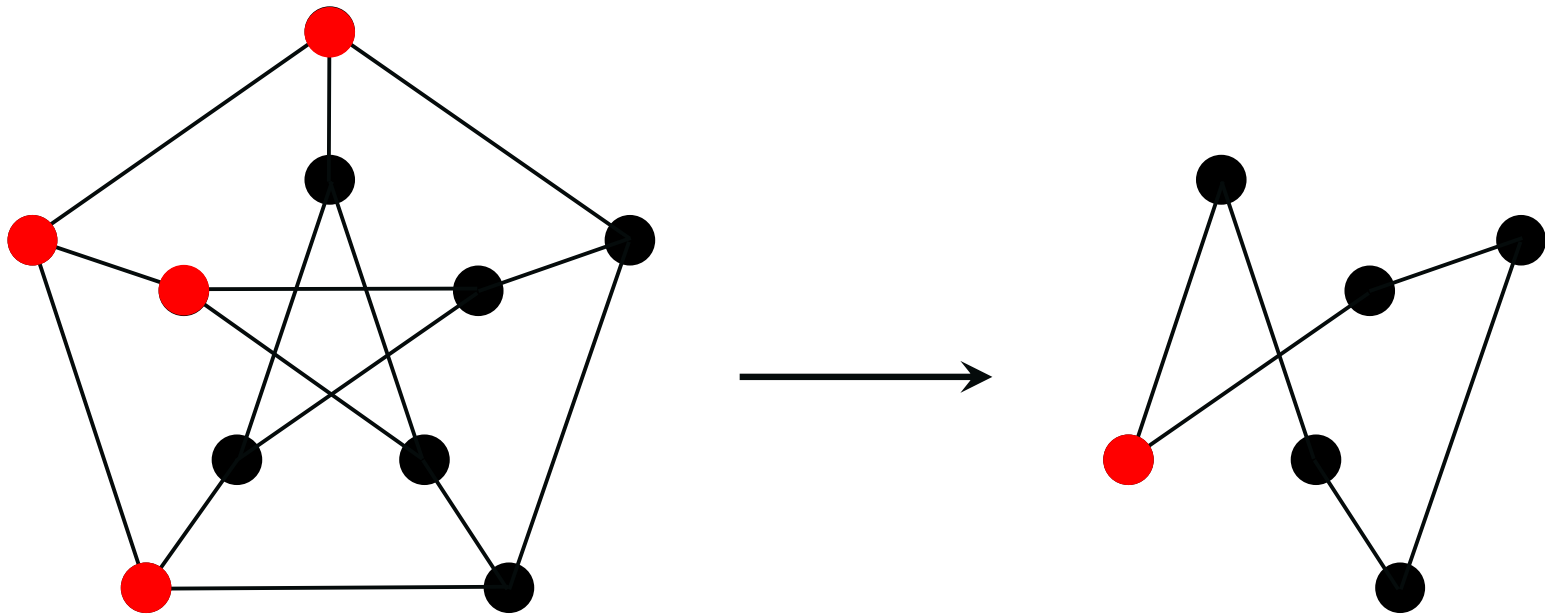

Would you prefer to be the **first player**? the **second player**?

# Let's first play...

---

Take your favorite graph, e.g. Petersen graph.

On her turn, each player chooses a vertex and deletes its closed neighbourhood...

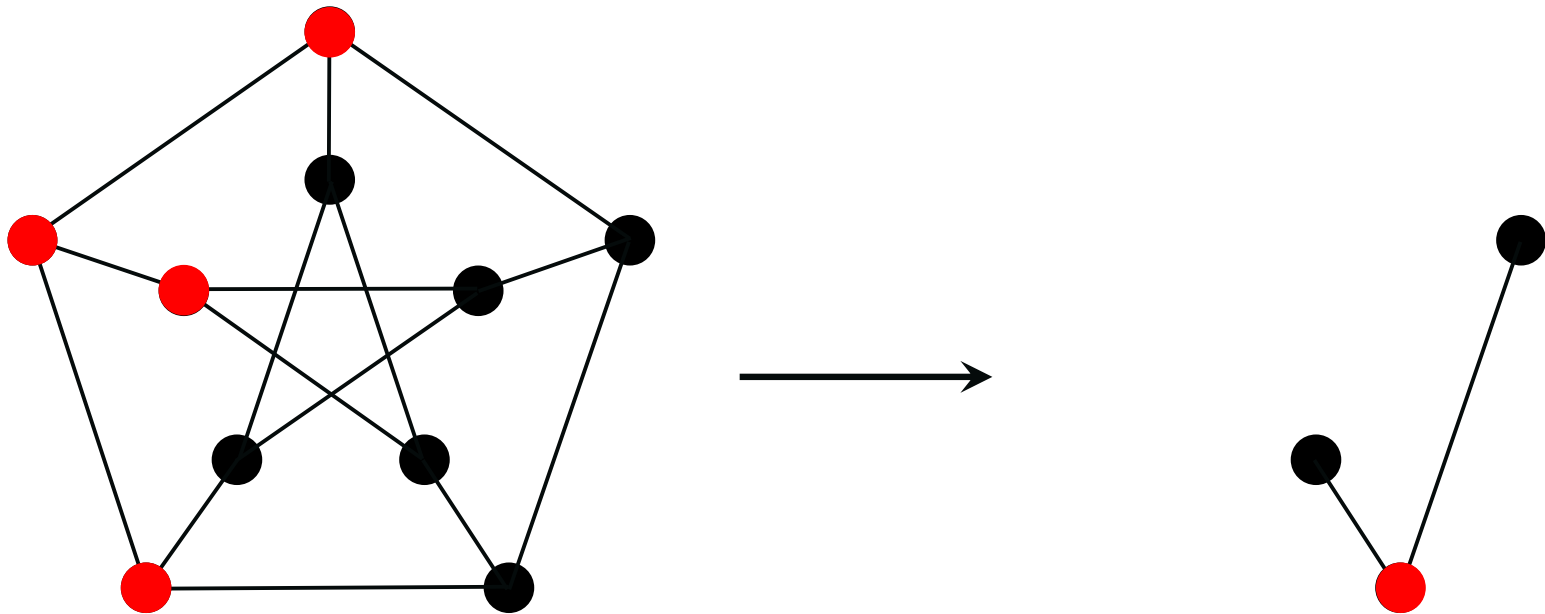

Would you prefer to be the **first player**? the **second player**?

# Let's first play...

---

- Suppose now that the initial graph is **the complete graph  $K_n$**  on  $n$  vertices...

Would you prefer to be the first player? the second player?

*Of course, the first player **always wins**...*

- And if the initial graph is **the path  $P_n$**  on  $n$  vertices?

Would you prefer to be the first player? the second player?

*Hum hum... seems not so easy...*

*In that case, the first player **looses** if and only if either*

- *$n = 4, 8, 14, 20, 24, 28, 34, 38, 42$ , or*
- *$n > 51$  and  $n \equiv 4, 8, 20, 24, 28 \pmod{34}$ .*

# Let's first play...

---

Let us now change the “winning rule” as follows: **the first player unable to move wins the game...**

The case of  $K_n$  is again easy: *the first player always loses...*

The first player still wins the game on Petersen graph:

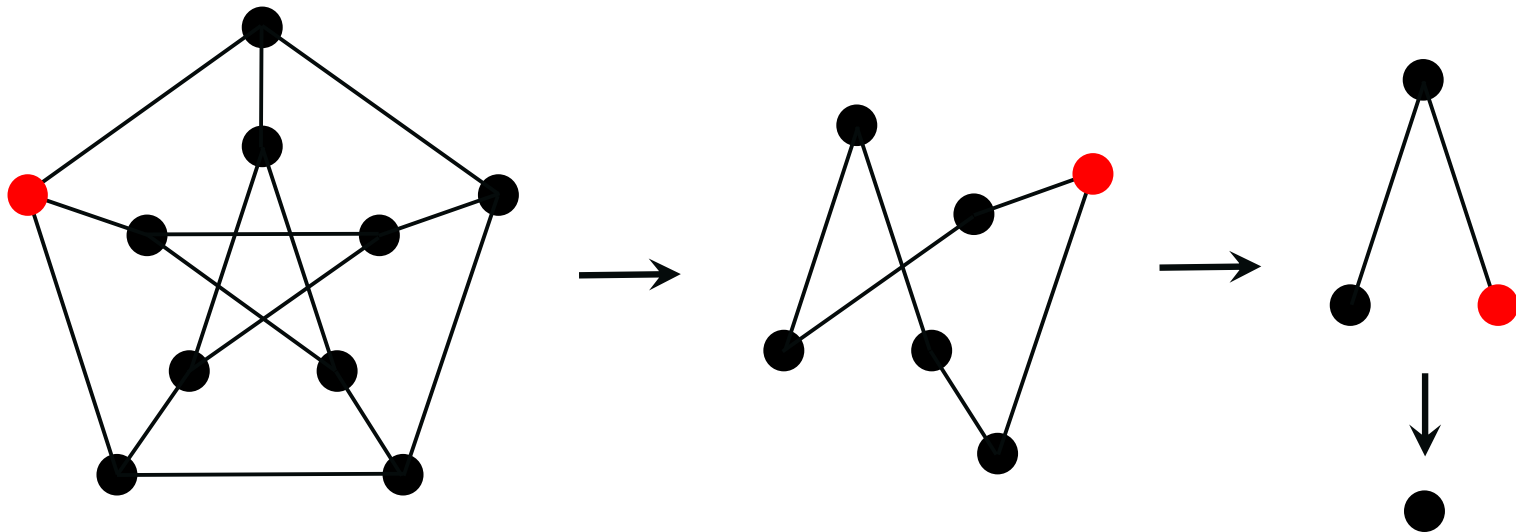

# Let's first play...

Let us now change the “winning rule” as follows: **the first player unable to move wins the game...**

What about the game on the path  $P_n$ ?

*Again not easy...*

*Really not easy: a well-known open problem since 1935!...*

This game is known as the **DAWSON'S CHESS** game.

**T. R. DAWSON. *Caissa's Wild Roses*. Problem #80 (1935).**

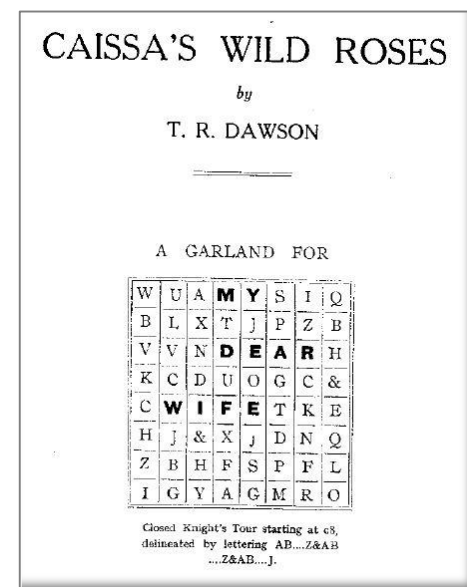
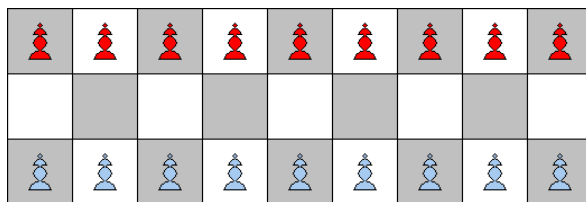



# Outline

---

## *Starters*

A flavour of  
Combinatorial  
Game Theory

*Impartial games – Sums of  
games – Sprague-Grundy  
value – Game-graph...*

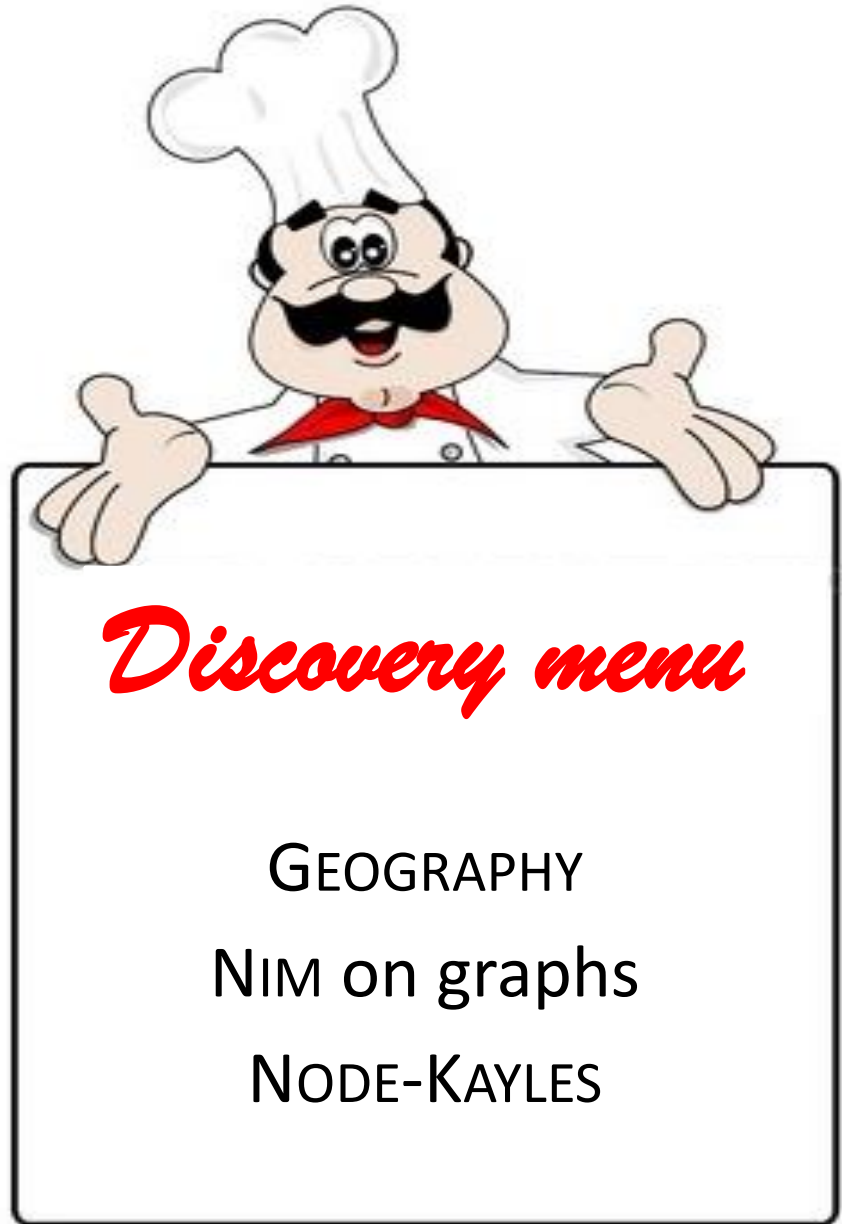

# A flavour of Combinatorial Game Theory



## Combinatorial game

A **combinatorial game** is a 2-player game such that:

- players alternate in turn,
- there is no hidden information and no chance elements,
- the number of **positions** (configurations) is finite,
- no position can be encountered twice during a game (the game is thus finite).

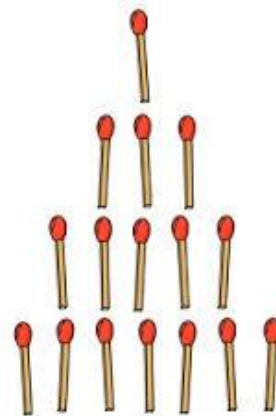
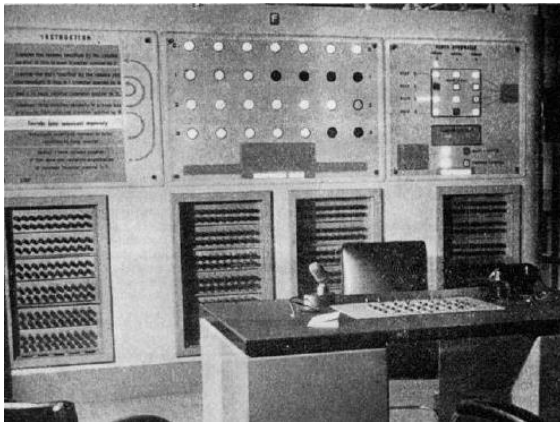

## Winning rule

➤ **Normal play**

The first player unable to move **loses** the game.

➤ **Misère play**

The first player unable to move **wins** the game.

The normal version is usually “easier” to deal with...

## Options

The set of rules of the game gives, for each position and each player, the **options** of this position.

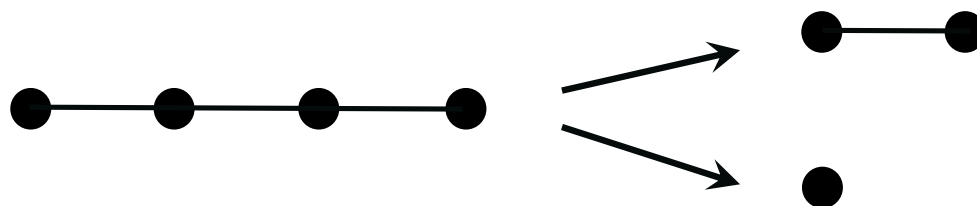

## Impartial vs partisan combinatorial games

The game is **impartial** if both players have the same options for every position, it is **partisan** otherwise.

# Combinatorial game theory

(1)

Since the mathematical solution of the game of NIM by C.L. BOUTON (1901), the theory of combinatorial games has been increasingly developed.

NIM, A GAME WITH A COMPLETE MATHEMATICAL THEORY.

BY CHARLES L. BOUTON.

THE game here discussed has interested the writer on account of its seeming complexity, and its extremely simple and complete mathematical theory.\*

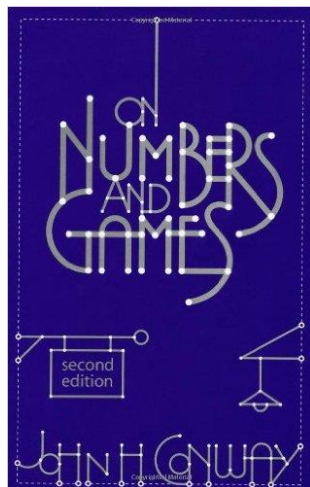

JOHN H. CONWAY

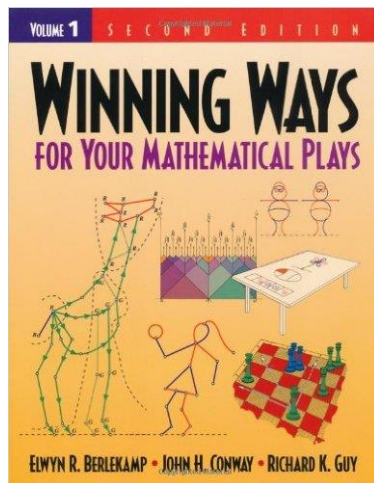

ELVYN R. BERLEKAMP  
JOHN H. CONWAY  
RICHARD K. GUY

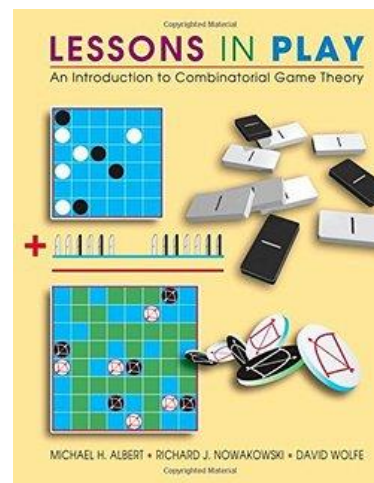

MICHAEL H. ALBERT  
RICHARD J. NOWAKOWSKI  
DAVID WOLFE

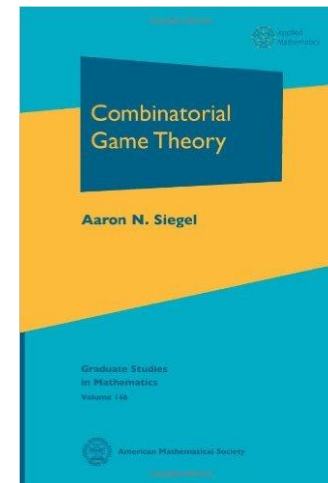

AARON N. SIEGEL

## Outcomes

### The Fundamental Theorem

*If  $G$  is an impartial game then either the first or the second player can force a win.*

Therefore, every position of an impartial combinatorial game is either a **winning position** (1st-player wins), or a **losing position** (2nd-player wins).

Observe that

- $G$  is a **winning position** iff  $G$  has *at least one* **losing** option,
- $G$  is a **losing position** iff  $G$  has *only* **winning** options.

## Sum of games

Let  $G_1$  and  $G_2$  be two games. The (disjunctive) **sum of  $G_1$  and  $G_2$**  is the game  **$G_1 + G_2$** , played as follows:

- on her turn, each player chooses the current position **in  $G_1$  or in  $G_2$** , and then moves according to the rules of  $G_1$  or  $G_2$ , respectively,
- the game ends as soon as a player has **no move in any of the two games**.

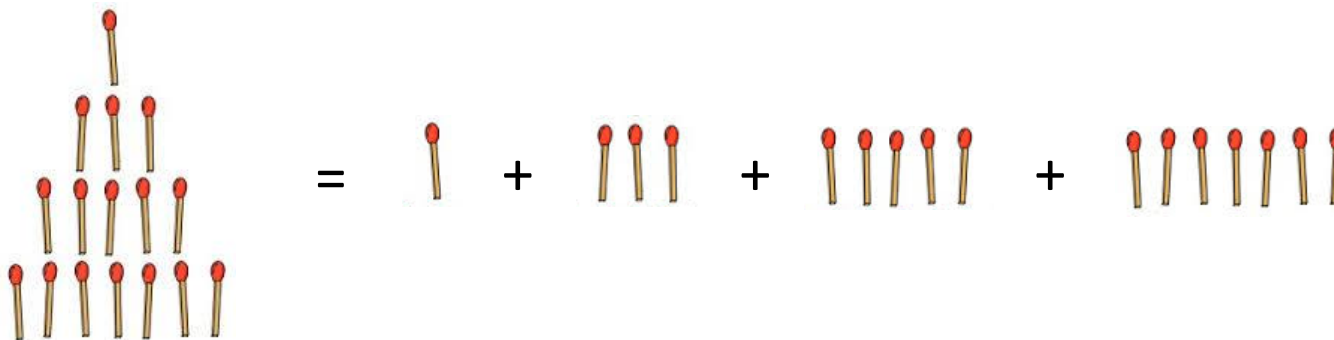
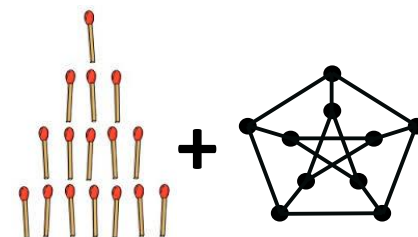



## Sum of games

Let  $G_1$  and  $G_2$  be two games. The (disjunctive) **sum of  $G_1$  and  $G_2$**  is the game  **$G_1 + G_2$** , played as follows:

- on her turn, each player chooses the current position **in  $G_1$  or in  $G_2$** , and then moves according to the rules of  $G_1$  or  $G_2$ , respectively,

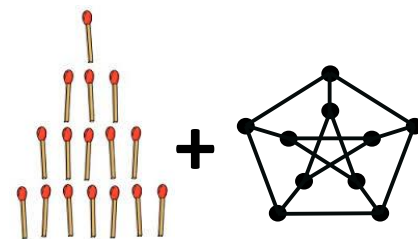

- the game ends as soon as a player has **no move in any of the two games**.

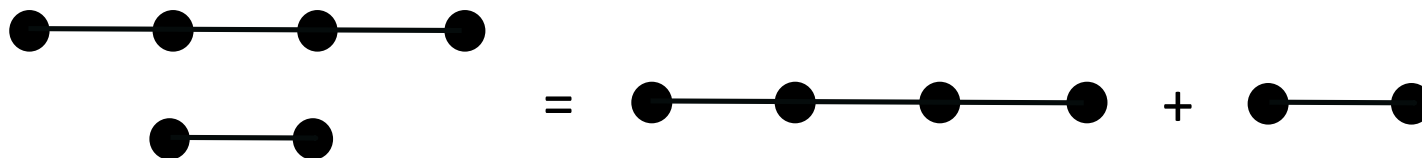

## Outcome of the sum of two games (normal play)

Knowing the outcome of both games  $G_1$  and  $G_2$  does not suffice for determining the outcome of  $G_1 + G_2$ ...

Outcome of $G_1 + G_2$		
$G_1 \setminus G_2$	winning	losing
winning	????	winning
losing	winning	losing

## The Sprague-Grundy function (impartial games, normal)

### Theorem [R.P. SPRAGUE, 1935 – P.M. GRUNDY, 1939]

*Every game  $G$  is “equivalent” to the game of NIM on a heap of  $n$  tokens (or a row of  $n$  matches) for some positive integer  $n$ .*

Two games  $G$  and  $H$  are **equivalent** whenever we can replace any occurrence of  $G$  by  $H$  in any sum of games, without changing the outcome of the sum (in particular,  $G$  and  $H$  have the same outcome)...

We then set  $\sigma(G) = n$  ( $n$  is the **Sprague-Grundy value** of  $G$ ).

Therefore, a game  $G$  is a **2<sup>nd</sup>-player** win if and only if  $\sigma(G) = 0$ .

*(Every heap with  $n > 0$  tokens is a **winning** position.)*

## Computing the SG-value of an impartial game (1)

If the set of options of  $G$  is  $\{G_1, \dots, G_k\}$ , then

$$\sigma(G) = \text{mex}(\sigma(G_1), \dots, \sigma(G_k))$$

where  $\text{mex}(S)$  is the smallest positive integer value not in  $S$  (in particular,  $\text{mex}(\emptyset) = 0$ ).

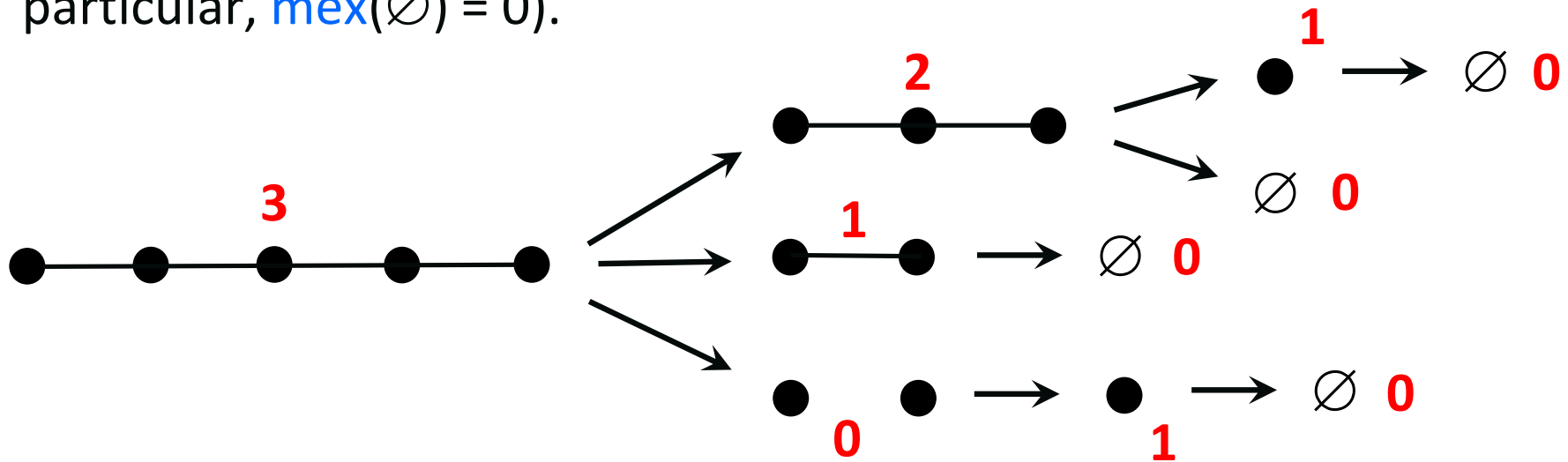

is thus a **winning position**...



# The graph of a combinatorial game

## Game-graph

With every impartial combinatorial game  $G$ , one can associate a graph (the **game-graph of  $G$** ), denoted  $G_g$  and defined as follows:

- vertices of  $G_g$  are **positions** of  $G$ ,
- $P_1 P_2$  is an arc in  $G_g$ , whenever  $P_2$  is an **option** of  $P_1$ .

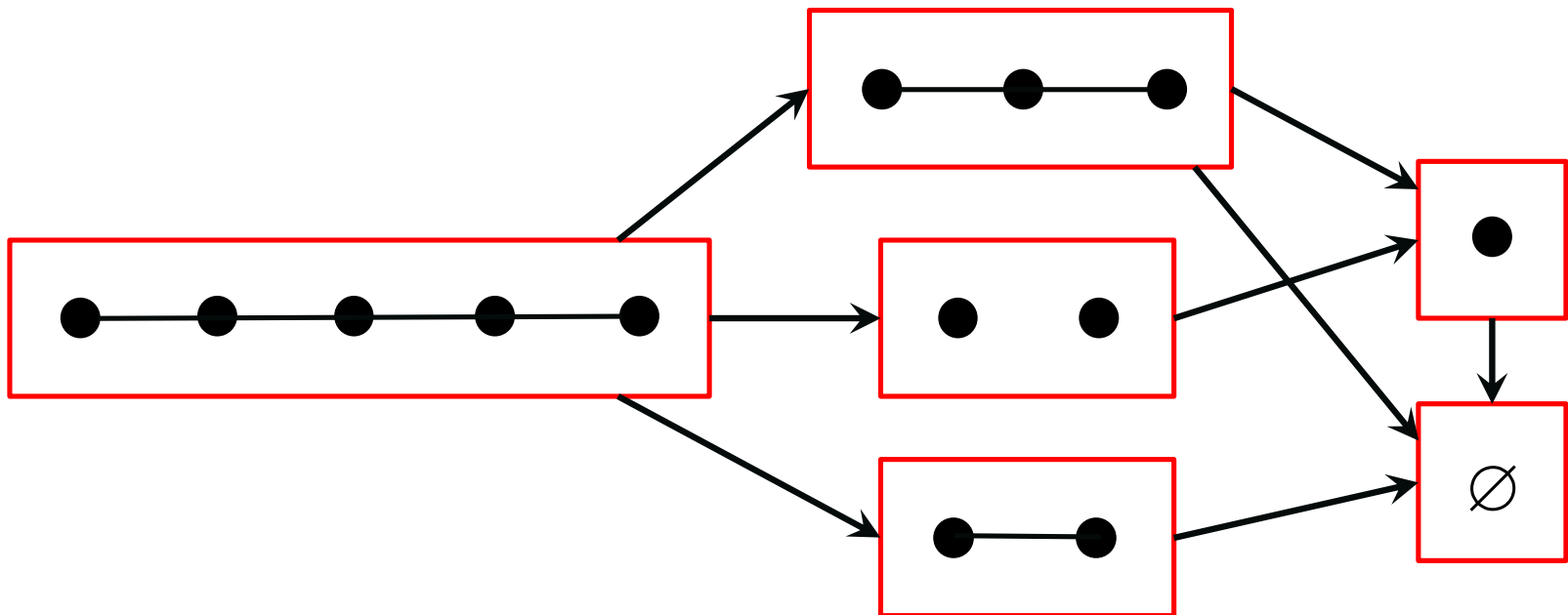

# Playing on the game-graph

## Playing on $G_g$

Every impartial combinatorial game  $G$  can be viewed as a game on the oriented graph  $G_g$  defined as follows:

- a **token** is put on the **initial vertex** (initial position),
- on her turn, each player **moves the token along one arc**,
- the first player unable to move **loses** (or **wins...**).

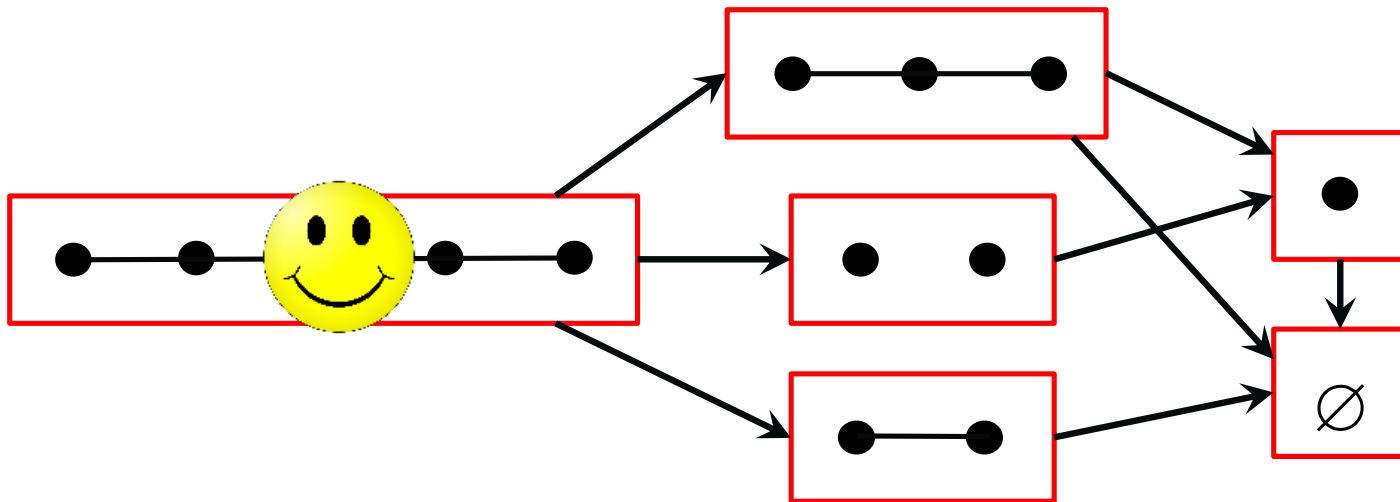

# The game GEOGRAPHY

Poland → Denmark → Kenya → Australia → ??



## VERTEX GEOGRAPHY [suggested by R.M. KARP]

The game is played on an undirected graph  $G$ . Initially, a token is placed on some “current vertex”  $v$  (starting position  $(G, v)$ ).

- On her turn, each player **moves** the token to a neighbour of the current vertex and **deletes the current vertex**.

The vertex having the token becomes the new current vertex.

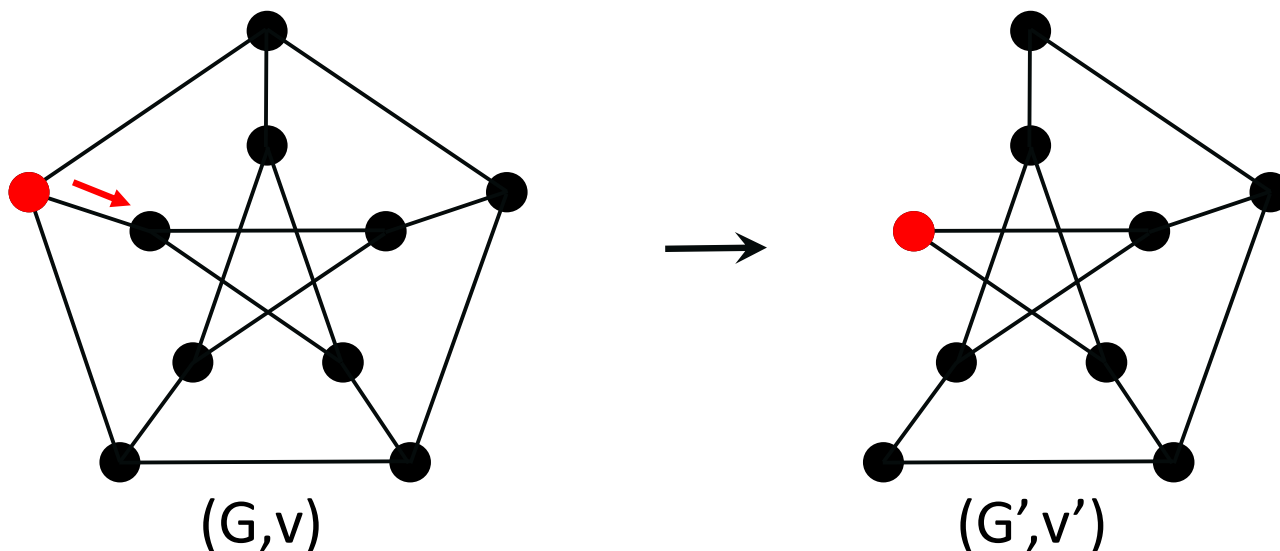

## EDGE GEOGRAPHY

The game is played on an undirected graph  $G$ . Initially, a token is placed on some “current vertex”  $v$  (starting position  $(G,v)$ ).

- On her turn, each player **moves** the token to a neighbour of the current vertex and **deletes the traversed edge**.  
The vertex having the token becomes the current vertex.

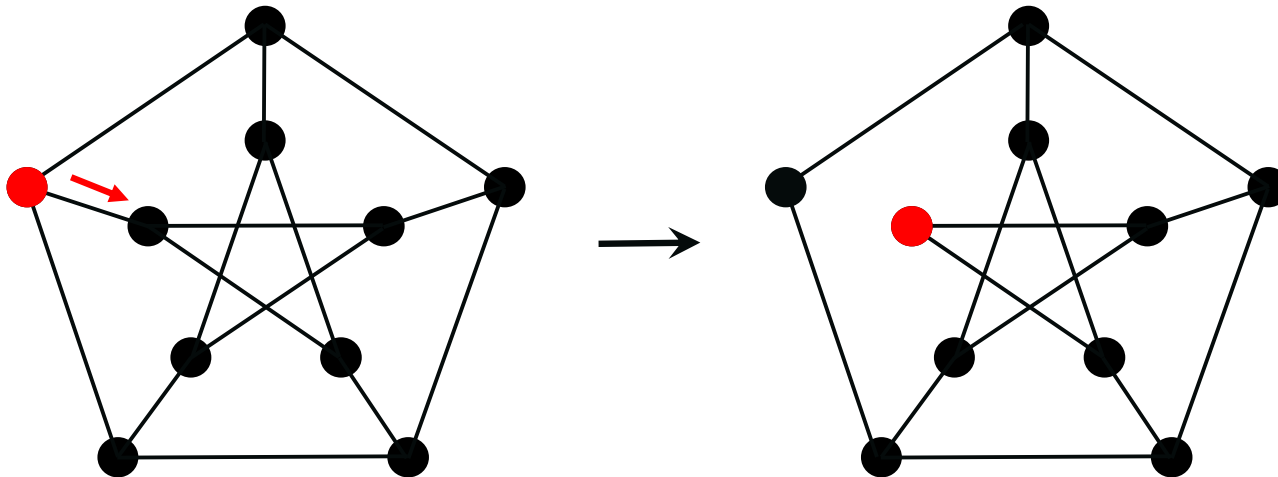

## DIRECTED (VERTEX OR EDGE) GEOGRAPHY

The game is played on a directed graph....

**Playing on a game-graph = DIRECTED VERTEX GEOGRAPHY...**

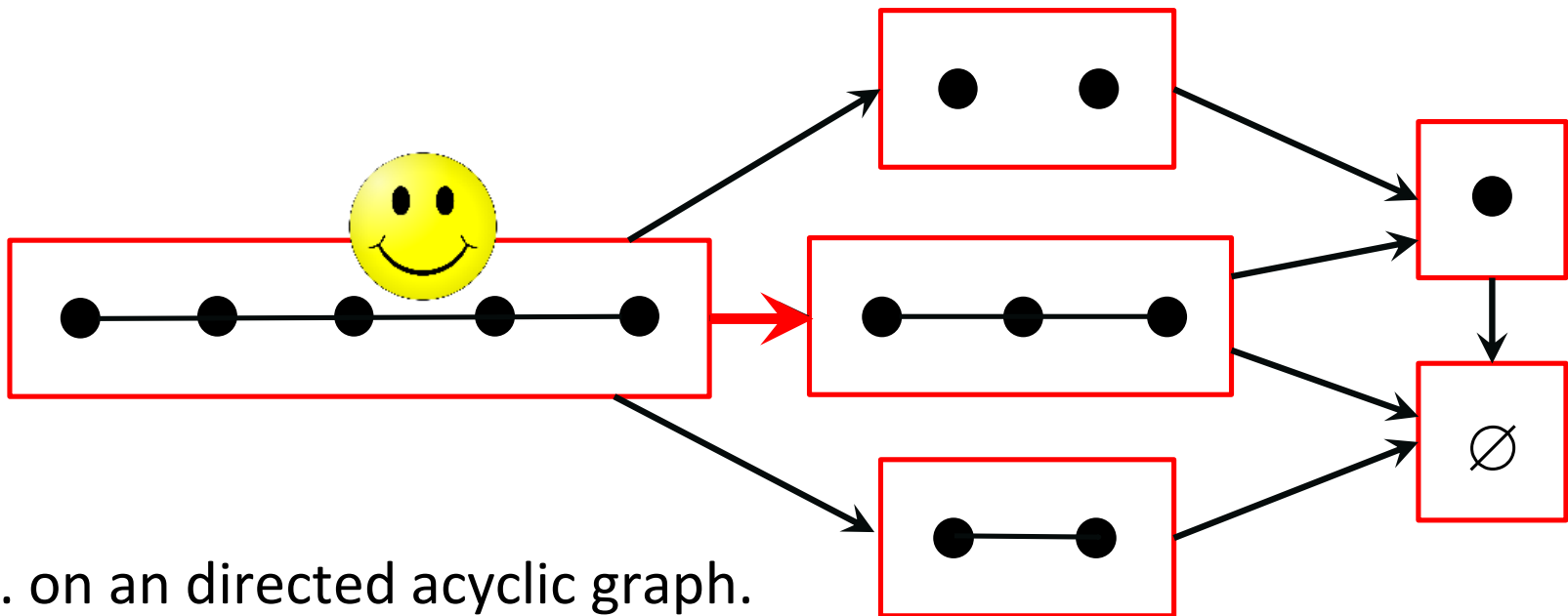

## DIRECTED (VERTEX OR EDGE) GEOGRAPHY

The game is played on a directed graph....

**Playing on a game-graph = DIRECTED VERTEX GEOGRAPHY...**

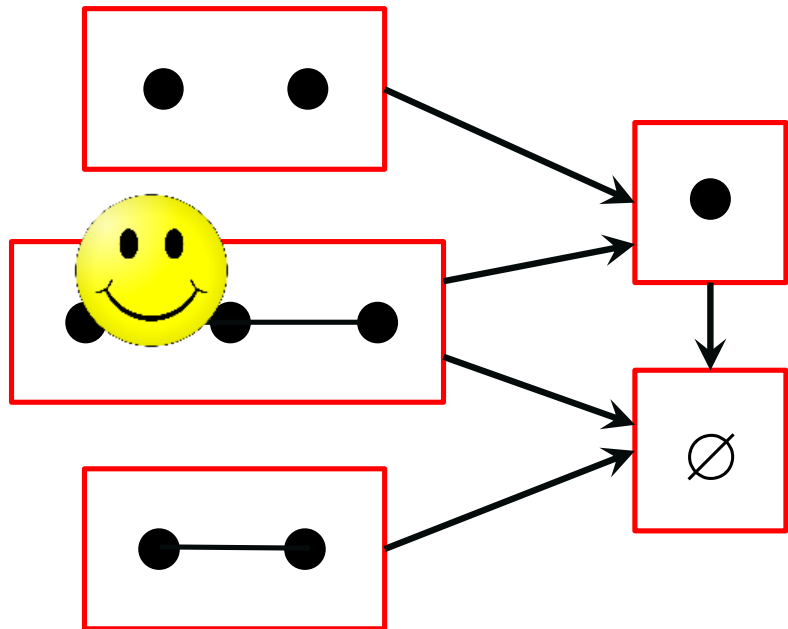

... on an directed acyclic graph.

## DIRECTED (VERTEX OR EDGE) GEOGRAPHY

The game is played on a directed graph....

## Complexity of GEOGRAPHY games (normal play)

*(deciding the outcome of a given position)*

UNDIRECTED VERTEX:	polynomial	[A.S. FRAENKEL, E.R. SCHEINERMAN, D. ULLMAN, 1993]
UNDIRECTED EDGE:	PSPACE-complete	[A.S. FRAENKEL, E.R. SCHEINERMAN, D. ULLMAN, 1993]
DIRECTED VERTEX:	PSPACE-complete	[D. LICHTENSTEIN, M. SIPSER, 1980]
DIRECTED EDGE:	PSPACE-complete	[T.J. SCHAEFER, 1978]

## DIRECTED (VERTEX OR EDGE) GEOGRAPHY

The game is played on a directed graph....

## Complexity of GEOGRAPHY games

But for **misère play**, all these four games are PSPACE-complete...

[G. RENAULT, S. SCHMIDT, 2015]

# UNDIRECTED VERTEX GEOGRAPHY

**Theorem [A.S. FRAENKEL, E.R. SCHEINERMAN, D. ULLMAN, 1993]**

*The position  $(G, v)$  is a winning position for the game **UNDIRECTED VERTEX GEOGRAPHY** (normal play) iff every maximum matching (that is, of maximum cardinality) of  $G$  saturates  $v$ .*

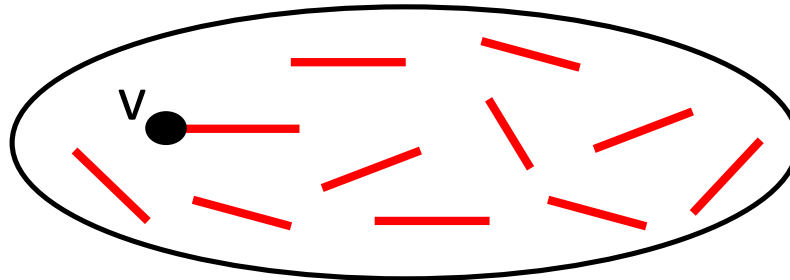

**Proof.**

- $(\Rightarrow)$  **2<sup>nd</sup>-player winning strategy:** choose a maximum matching  $M$  that does not saturate  $v$ , and always move along an edge in  $M$ .
- $(\Leftarrow)$  **1<sup>st</sup>-player winning strategy:** choose a maximum matching  $M$  (which thus saturates  $v$ ) and always move along an edge in  $M$ .  
(if no such move is possible, there exists  $M'$  which does not saturate  $v$ ...)

# DIRECTED VERTEX GEOGRAPHY

## Theorem [R.J. NOWAKOWSKI, D.G. POOLE, 1996]

The position  $(C_m \square C_n, v)$  is a *winning position* for the game DIRECTED VERTEX GEOGRAPHY whenever:

- $m = 2$ , or
- $n$  and  $m$  are both even.

## Theorem [R.J. NOWAKOWSKI, D.G. POOLE, 1996]

The position  $(C_3 \square C_n, v)$  is a *winning position* for the game DIRECTED VERTEX GEOGRAPHY iff  $n > 0$  and  $n \equiv 0, 2, 4, 6, 10, 11, 13, 15, 16, 17, 19, 21, 22, 23, 25, 27, 28, 32, 34, 36, 38, 40 \pmod{42}$ .

## Theorem [M.S. HOGAN, D.G. HORROCKS, 2003]

The position  $(C_4 \square C_n, v)$  is a *losing position* for the game DIRECTED VERTEX GEOGRAPHY iff  $n \equiv 11 \pmod{12}$ .



# Geography – Open problem

---

## **Open Problem.**

For which classes of graphs the outcome of GEOGRAPHY (any variant) is “easy” to determine?



## EDGE NIMG [M. FUKUYAMA, 2003]

- each **edge** contains a given (non-negative) number of **tokens**,
- one vertex of the graph is the **starting vertex**,
- one action:
  - **move** to a neighbour of the current vertex and **delete** any non-negative number of tokens on the traversed edge.

EDGE NIMG extends ordinary NIM:

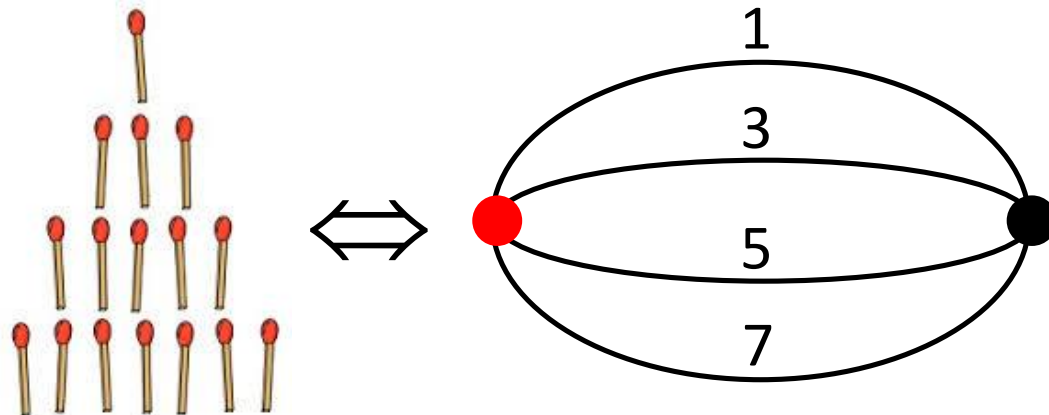

## EDGE NIMG [M. FUKUYAMA, 2003]

- each **edge** contains a given (non-negative) number of **tokens**,
- one vertex of the graph is the **starting vertex**,
- one action:
  - **move** to a neighbour of the current vertex and **delete** any non-negative number of tokens on the traversed edge.

EDGE NIMG extends UNDIRECTED EDGE GEOGRAPHY (PSPACE-complete):

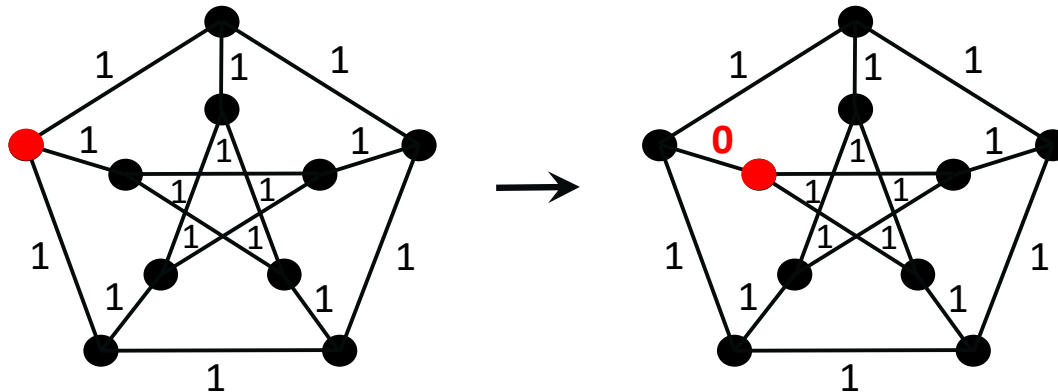

## EDGE NIMG [M. FUKUYAMA, 2003]

- each **edge** contains a given (non-negative) number of **tokens**,
- one vertex of the graph is the **starting vertex**,
- one action:
  - **move** to a neighbour of the current vertex and **delete** any non-negative number of tokens on the traversed edge.

FUKUYAMA determined the **Sprague-Grundy values** of EDGE NIMG positions whenever  $G$  is either **a cycle or a tree**.

He also determined whether a position is a **winning** or a **losing** position whenever  **$G$  is bipartite**...

L. ERICKSON (2010), studied the case where **each edge has exactly one token** (UNDIRECTED EDGE GEOGRAPHY), and gave several sufficient conditions for a position to be a **winning position**.

- If  $G$  contains two twin vertices  $v_1$  and  $v_2$  (that is,  $v_1$  and  $v_2$  have the same closed neighbourhood) then the position  $(G, v_1)$  is a **winning position** [L. ERICKSON, 2010].
- Therefore, every position  $(K_n, v)$ ,  $n \geq 2$ , is a **winning position**.
- Let  $Q_n$  denote the  $n$ -dimensional hypercube. A position  $(Q_n, v)$  is a **winning position** iff  **$n$  is odd** [L. ERICKSON, W. SHREVE, 2012].

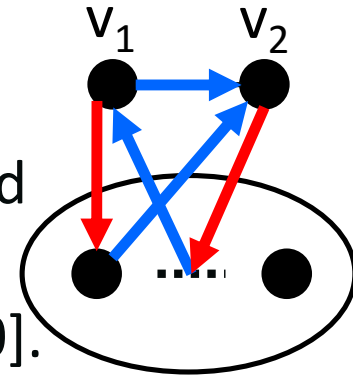

## Open Problem.

- What about such graphs with **an arbitrary number** of tokens at each vertex? with **at most 2** tokens?

## VERTEX NIMG [G. STOCKMAN, A. FRIEZE, J. VERA, 2004]

- each **vertex** contains a given (non-negative) number of **tokens**,
- one vertex of the graph is the **starting vertex**,
- two actions:
  - **delete** any non-negative number of tokens on the current vertex,
  - **move** to a neighbour of the current vertex.

Several variants can thus be considered:

**delete-then-move** or **move-then-delete**

loops on vertices are allowed or not (move-then-delete)

move to an “empty vertex” is allowed or not (delete-then-move)

## VERTEX NIMG, delete-then-move, no loop

- If the number of tokens is bounded by some constant, then deciding whether a position is **winning** or **losing** can be done in polynomial time [G. STOCKMAN, A. FRIEZE, J. VERA, 2004].

## VERTEX NIMG, move-then-delete, loop on every vertex

- If the number of tokens is **bounded by some constant  $k \geq 2$** , then deciding whether a position is **winning** or **losing** is PSPACE-complete [K.G. BURKE, O.C. GEORGE, 2014].

### Open Problem.

- What is the computational complexity of VERTEX NIMG on graphs with **optional** loops?



In all versions of NIMG, the game may end with remaining tokens on the graph, contrary to ordinary NIM...

## UNDIRECTED VERTEXNIM [E. DUCHÊNE, G. RENAULT, 2014]

- Variant of delete-then-move VERTEX NIMG:
  - **delete** any non-negative number of tokens on the current vertex,
  - **move** to the next current vertex (having a non-negative number of tokens), *along a path whose internal vertices do not have any token.*
- The outcome of any UNDIRECTED VERTEXNIM position (loops are allowed) can be computed in **polynomial time**.

## DIRECTED VERTEXNIM [E. DUCHÊNE, G. RENAULT, 2014]

- The outcome of any DIRECTED VERTEXNIM position (a loop at each vertex, the graph is strongly connected) can be computed in polynomial time.
- Let  $C_n$  be a directed cycle of order  $n$ ,  $n \geq 3$ , with at least 2 tokens at each vertex. For every vertex  $v$ , the outcome of the position  $(C_n, v)$  can be computed in polynomial time.

### Open Problems.

- What about strongly connected graphs with optional loops?
- What about  $C_n$  if some vertices have only 1 token?
- What about the move-then-delete version?

# NODE-KAYLES

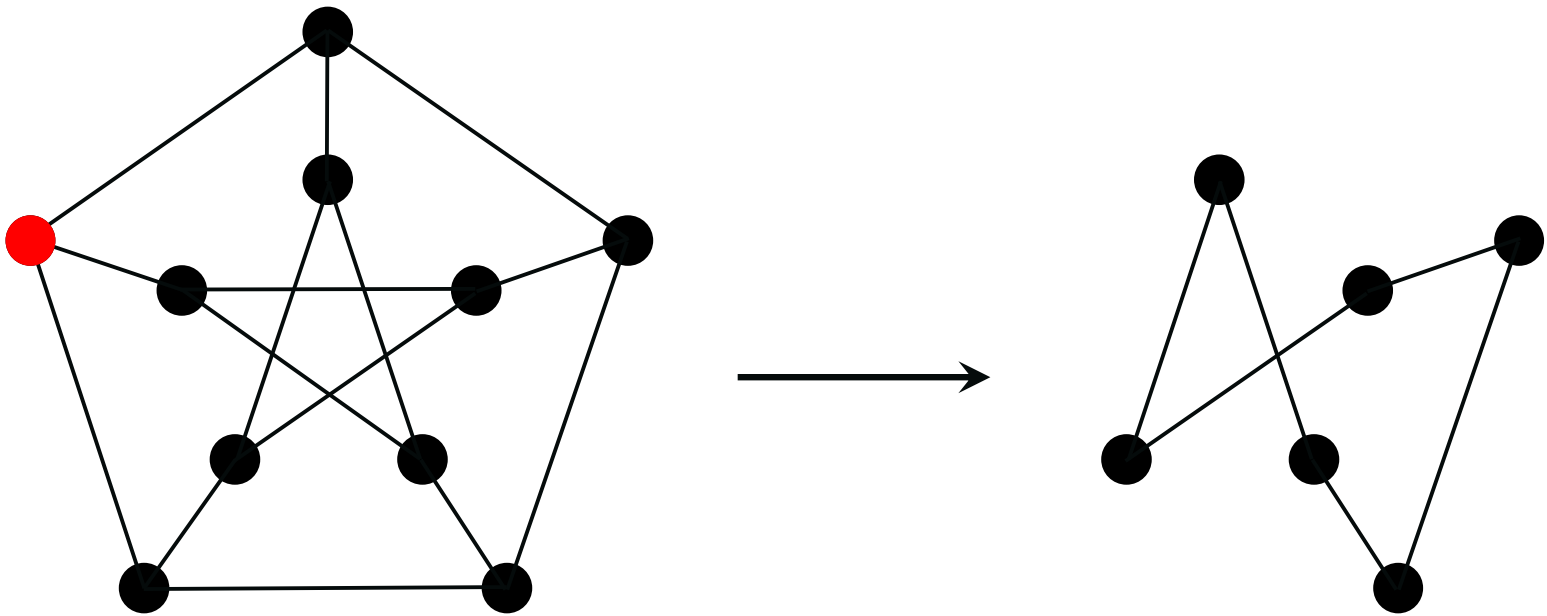

## Theorem [T.J. SCHAEFER, 1978]

*Determining whether a given position (graph) is a winning position or a losing position for NODE-KAYLES is **PSPACE-complete**.*

## Theorem [H. BODLAENDER, D. KRATSCH, 2002]

*Determining whether a given position  $G$  is a winning position or a losing position for NODE-KAYLES is **polynomial** whenever  $G$  is a cocomparability graph, a circular arc graph, a cograph, or has bounded asteroidal number.*

## Theorem [R. FLEISCHER, G. TRIPPEN, 2004]

Determining whether a *subdivided star* with bounded degree is a winning position or a losing position for NODE-KAYLES is *polynomial*.

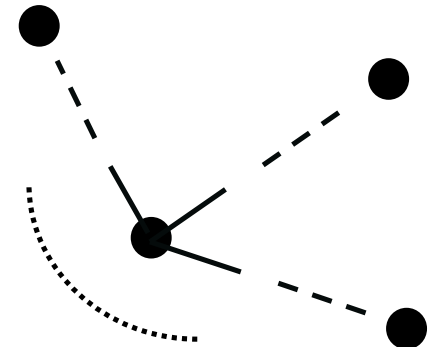

## Theorem [H. BODLAENDER, D. KRATSCH, 2011]

Determining whether a given position  $G$  with  $n$  vertices is a winning position or a losing position for NODE-KAYLES can be done in time  $O(1.6052^n)$ , or in time  $O(1.4423^n)$  if  $G$  is a tree.

# NODE-KAYLES on paths (DAWSON'S CHESS)

## Sprague-Grundy sequence

The **Sprague-Grundy sequence** of NODE-KAYLES on paths is the (infinite) sequence of Sprague-Grundy values:

$$\sigma(P_1) \sigma(P_2) \sigma(P_3) \dots \sigma(P_n) \dots$$

The Sprague-Grundy sequence of NODE-KAYLES on paths is **ultimately periodic**, with a period of length **34** and a preperiod of length **51**:

<u>0</u>	1	1	2	<u>0</u>	3	1	1	<u>0</u>	3	3	2	2	4	<u>0</u>	5	2	2
18	3	3	<u>0</u>	1	1	3	<u>0</u>	2	1	1	<u>0</u>	4	5	2	7	4	<u>0</u>
35	1	1	2	<u>0</u>	3	1	1	<u>0</u>	3	3	2	2	4	4	5	5	2
52	3	3	<u>0</u>	1	1	3	<u>0</u>	2	1	1	<u>0</u>	4	5	3	7	4	8
69	1	1	2	<u>0</u>	3	1	1	<u>0</u>	3	3	2	2	4	4	5	5	9
86	3	3	<u>0</u>	1	1	3	<u>0</u>	2	1	1	<u>0</u>	4	5	3	7	4	8
103	1	1	2	<u>0</u>	3	1	1	<u>0</u>	3	3	2	2	4	4	5	5	9
120	3	3	<u>0</u>	1	1	3	<u>0</u>	2	...								

## Sum of games (reminder)

The (disjunctive) sum of  $G_1$  and  $G_2$  is the game  $G_1 + G_2$ , played as follows:

- on her turn, each player chooses the current position in  $G_1$  or in  $G_2$ , and then moves according to the rules of  $G_1$  or  $G_2$ , respectively,
- the game ends as soon as a player has no move in any of the two games.

## Compound games

In his book (1976), JOHN H. CONWAY introduced 12 distinct notions of compound games, following an inspiring paper of C.A.B. SMITH (1966).

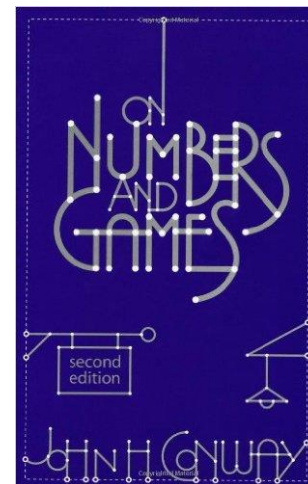

# Compound games

(2)

How to play in  $G_1 + \dots + G_k$ ?

➤ **Component selection**

- one component (**disjunctive sum**),
- all components (**conjunctive sum**),
- any number of components, at least one (**selective sum**).

➤ **Ending rule**

- all components have ended (**long rule**),
- one component has ended (**short rule**).

➤ **Winning rule**

- **normal** play,
- **misère** play.

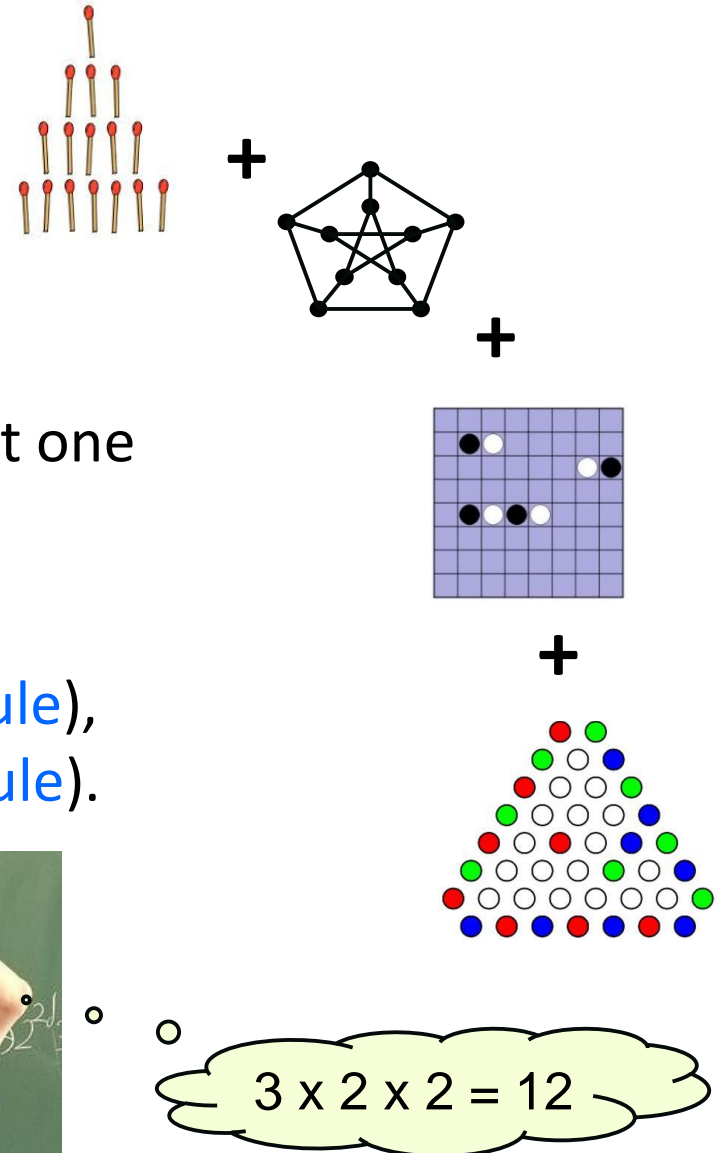



# Let's play again...

(1)

Let us consider the path  $P_5$  of order 5:

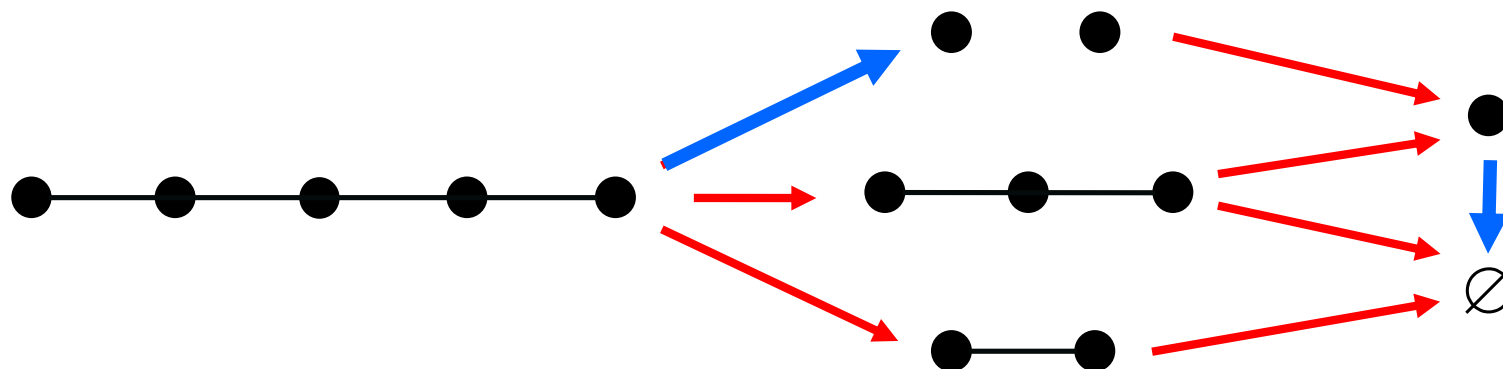

## Disjunctive sum, long rule, normal play

- Component selection: **one component**
- Ending rule: **all components must have ended**
- Winning rule: **the first player unable to move loses**

Is  $P_5$  a **winning** or a **losing** position?

**winning**

# Let's play again...

(2)

Let us consider the path  $P_5$  of order 5:

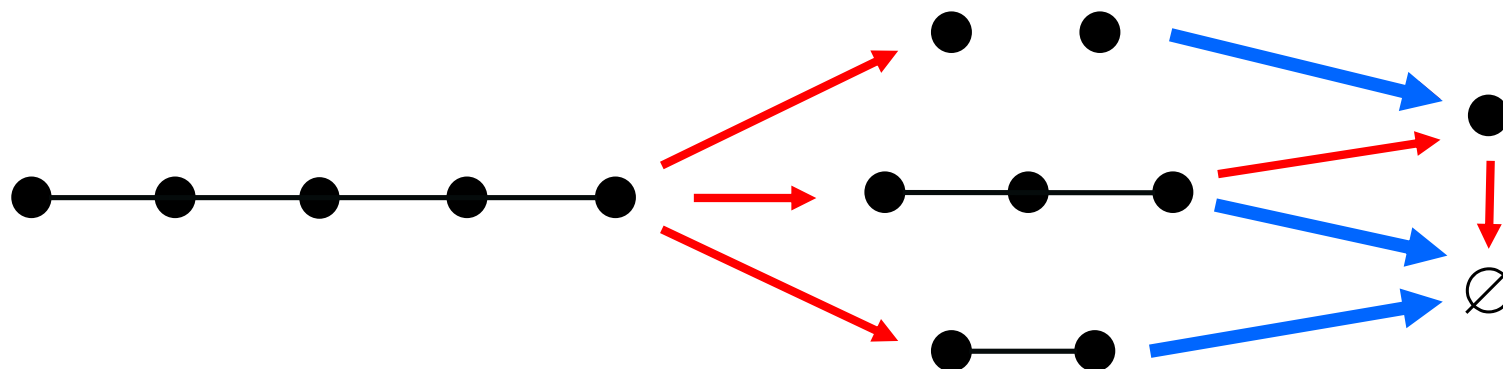

**Disjunctive sum, short rule, normal play**

- Component selection: **one component**
- Ending rule: **one component has ended**
- Winning rule: **the first player unable to move loses**

Is  $P_5$  a **winning** or a **losing** position?

**losing**

## Foreclosed Sprague-Grundy number of paths

- The foreclosed Sprague-Grundy sequence of paths (under normal play) is **ultimately periodic**:
  - preperiod of length **245**,
  - period of length **84**.
- The number of losing positions is **finite**:

*still open for  
misère play...*

$$L = \{ 0, 4, 5, 9, 10, 14, 28, 50, 54, 98 \}$$

$n$	$F^+(P_n)$				
0–49	****001120	0112031122	3112334105	3415534255	3225532255
50–99	0225042253	4423344253	4455341553	4285322853	4285442804
100–149	4283442234	4253345533	1253322533	2253422534	2253422334
150–199	2233425334	4533425532	2553425544	2554425344	2234425334
200–249	5533125342	2533225342	2534225342	2334223342	5334453342
250–299	<u>5532255342</u>	<u>5344255442</u>	<u>5344253442</u>	<u>5334553342</u>	<u>5342253322</u>
300–349	<u>5342253422</u>	<u>5342233422</u>	<u>3342533425</u>	3342553225	...

# Let's play again...

(3)

Let us consider the path  $P_5$  of order 5:

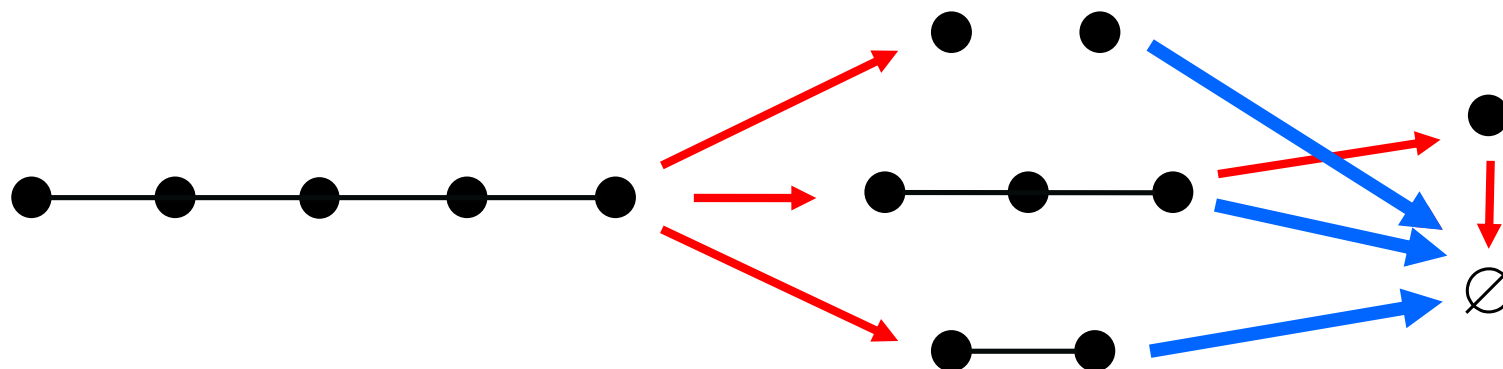

## Conjunctive sum, long rule, normal play

- Component selection: all components
- Ending rule: all components have ended
- Winning rule: the first player unable to move loses

Is  $P_5$  a **winning** or a **losing** position?

**losing**

## Suspense number

- Strategy: losing quickly on losing components and postponing win as long as possible on winning ones...
- The **suspense number**  $S^+(G)$  (normal play) of a position  $G$  is the number of coming turns, using this strategy:
  - $S^+(G) = 0$  if  $G$  is an ended position,
  - if  $G'$  is an option of  $G$  with **maximal even suspense**, then  $S^+(G) = S^+(G') + 1$ ,
  - if no such option exists and  $G''$  is an option of  $G$  with **minimal odd suspense**, then  $S^+(G) = S^+(G'') + 1$ .

A position  $G$  is a **winning** position iff  $S^+(G)$  is **odd**...

## Suspense number of paths

- The suspense sequence of paths (normal play) has a **geometric period** with **geometric ratio 2**.

For every  $n \geq 0$ , we have:

- $S^+(P_k) = 2n$ , if  $k = 5(2^n - 1)$ ,
  - $S^+(P_k) = 2n + 1$ , if  $5(2^n - 1) < k < 5(2^{n+1} - 1) - 1$ ,
  - $S^+(P_k) = 2n + 2$ , if  $k = 5(2^{n+1} - 1) - 1$ .
- The set of losing positions is:  
$$\{ 5(2^n - 1), n \geq 0 \} \cup \{ 5(2^{n+1} - 1) - 1, n \geq 0 \}$$

## Theorem [A. GUIGNARD, E.S., 2009]

*For ten over twelve versions of compound NODE-KAYLES on paths, the set of losing positions can be characterized.*

*The two remaining unsolved versions are the following:*

- *disjunctive sum, misère play, long rule (DAWSON'S problem, 1935),*
- *disjunctive sum, misère play, short rule.*

Compound version	Losing set $\mathcal{L}$
disj. comp., normal play	$\{0, 4, 8, 14, 19, 24, 28, 34, 38, 42\} \cup \{54 + 34i, 58 + 34i, 62 + 34i, 72 + 34i, 76 + 34i, i \geq 0\}$
disj. comp., misère play	<i>unsolved</i>
dim. disj. comp., normal play	$\{0, 4, 5, 9, 10, 14, 28, 50, 54, 98\}$
dim. disj. comp., misère play	<i>unsolved</i>
conj. comp., normal play	$\{0, 4, 5, 9, 10\}$
conj. comp., misère play	$\{1, 2\}$
cont. conj. comp., normal play	$\{5(2^n - 1), n \geq 0\} \cup \{5(2^{n+1} - 1) - 1, n \geq 0\}$
cont. conj. comp., misère play	$\{7 \cdot 2^n - 6, n \geq 0\} \cup \{7 \cdot 2^n - 5, n \geq 0\}$
sel. comp., normal play	$\{5n, n \geq 0\} \cup \{5n + 4, n \geq 0\}$
sel. comp., misère play	$\{7n + 1, n \geq 0\} \cup \{7n + 2, n \geq 0\}$
short. sel. comp., normal play	$\{5n, n \geq 0\} \cup \{5n + 4, n \geq 0\}$
short. sel. comp., misère play	$\{1, 2, 8, 9\} \cup \{5n, n \geq 3\} \cup \{5n + 4, n \geq 3\}$

## Graph colouring game (Maker/Breaker)

- Using a set of  $k$  colours, on her turn, each player **properly colours** an uncoloured vertex of a graph  $G$ .
- If **the whole graph is properly coloured** the 1<sup>st</sup> player wins the game, otherwise the 2<sup>nd</sup> player wins the game.
- The **game chromatic number** of  $G$  is the least integer  $k$  for which the 1<sup>st</sup> player has a winning strategy.

## Combinatorial graph colouring game

- Using a set of  $k$  colours, on her turn, each player **properly colours** an uncoloured vertex.
- The first player unable to move wins (or loses) the game...

[F. HARARY, Zs. TUZA, 1993]



## Observation.

*Playing the combinatorial graph colouring game on  $G$  with  $k$  colours is equivalent to playing NODE-KAYLES on  $G \square K_k$ .*

## Example with $k = 3$ :

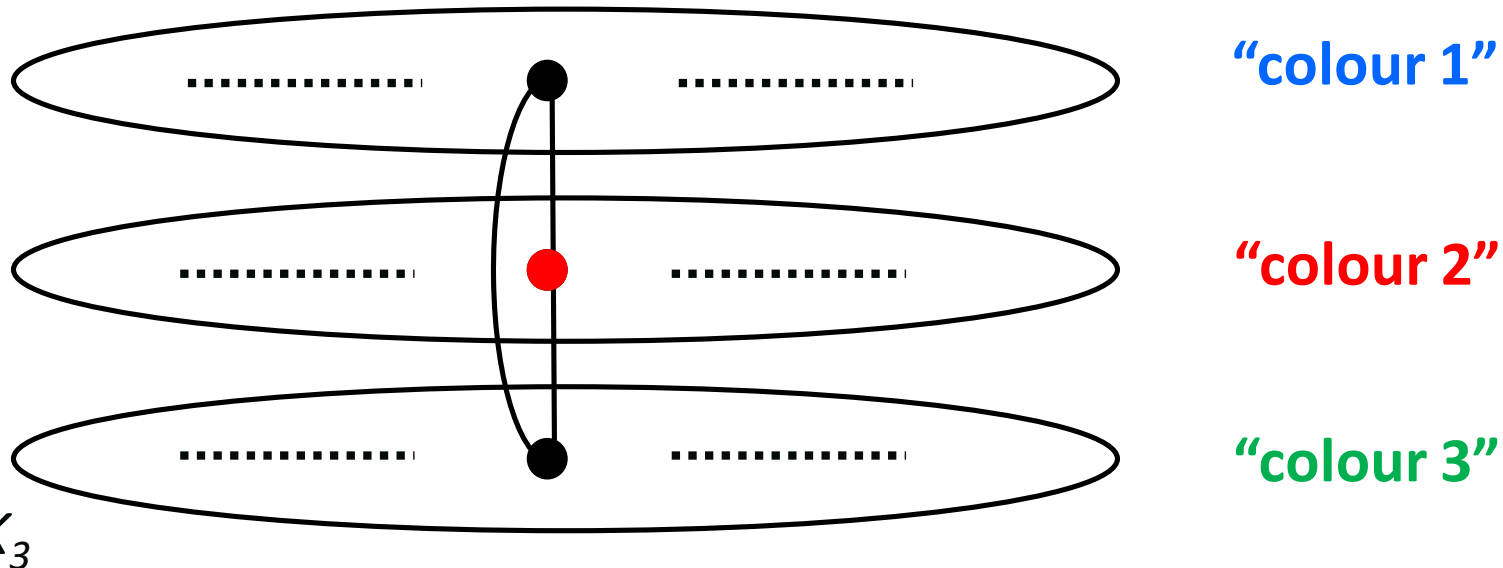

## Observation.

*Playing the combinatorial graph colouring game on  $G$  with  $k$  colours is equivalent to playing NODE-KAYLES on  $G \square K_k$ .*

## Example with $k = 3$ :

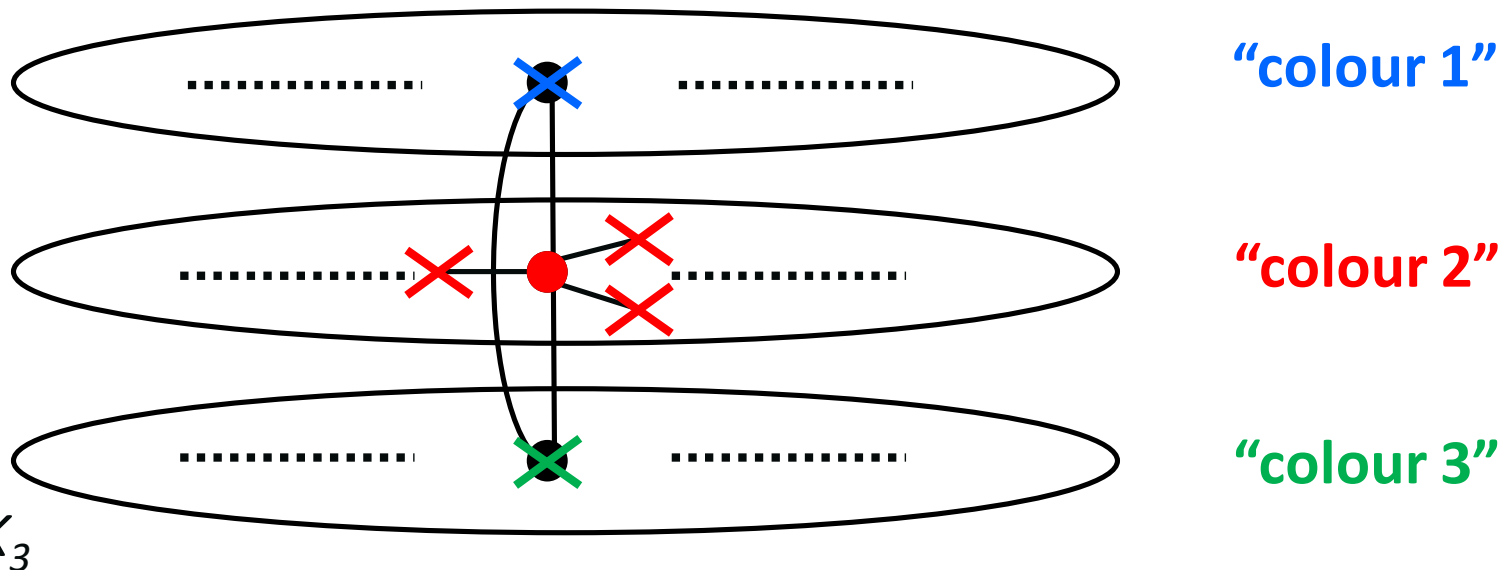

# NODE-KAYLES – Open problems

---

## Open Problems.

What about NODE-KAYLES on

- caterpillars?
- subdivided caterpillars?
- trees?
- ...

## Suggestion.

Consider compound versions of other combinatorial games?...

It's time to conclude...

# To conclude...

---

## Many other types of combinatorial games on graphs:

- Graph deletion games
- Avoidance / Achievement games (adding edges until some structure appears...)
- PEG DUOTAIRE (2-player version of PEG SOLITAIRE)
- Take your favourite “graph colouring problem” and consider its combinatorial game version...

Acyclic, 2-distance and a few others  
in [\[G. BEAULIEU, K. BURKE, E. DUCHÊNE, 2013\]](#)

- Partisan games (different options for players, e.g. playing with black or white tokens)
- ...



# To conclude...

---



GOTTFRIED WILHELM LEIBNIZ

*Human beings are never more ingenious than in the invention of games.*

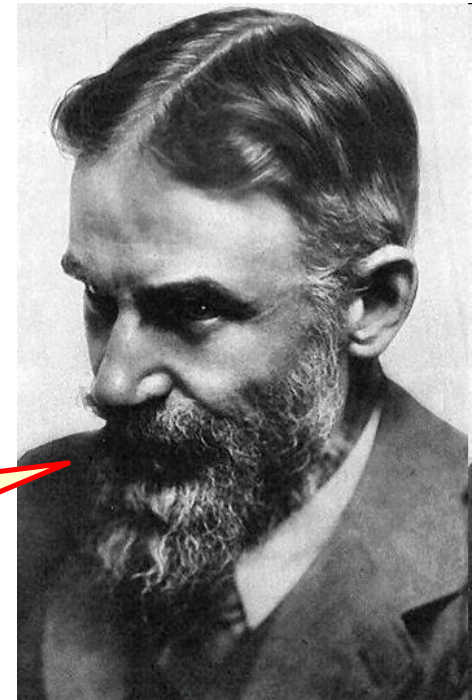

GEORGE BERNARD SHAW

*We don't stop playing because we grow old; we grow old because we stop playing.*

# To conclude...

---



**Thank you  
for your  
attention...**

GOTTFRIED WILHELM LEIBNIZ

*Human beings are never more ingenious than in the invention of games.*

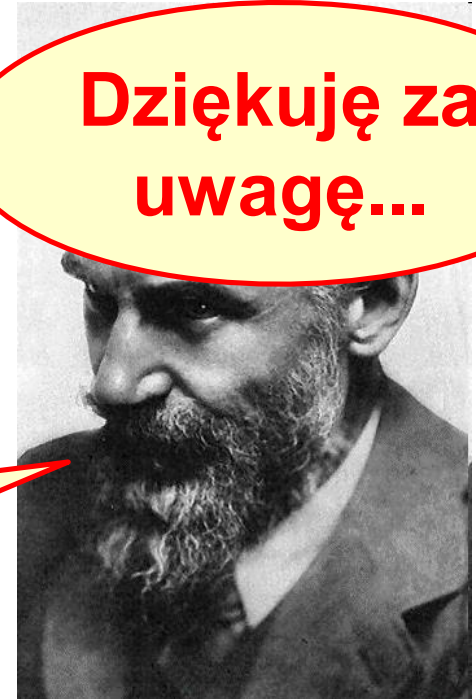

**Dziękuję za  
uwagę...**

GEORGE BERNARD SHAW

*We don't stop playing because we grow old; we grow old because we stop playing.*

# Announcement...

---



**Bordeaux Graph Workshop**

**BGW'2016**

November 7-10, 2016

[bgw.labri.fr](http://bgw.labri.fr)



**Invited speakers.** MARIA AXENOVICH, CSILLA BUJTÁS, KATHIE CAMERON, PAVOL HELL, ALEXANDR KOSTOCHKA, DANIEL KRÁL', CARSTEN THOMASSEN.