

# The incidence game chromatic number of $(a, d)$ -decomposable graphs<sup>☆</sup>

C. Charpentier<sup>a,b</sup>, É. Sopena<sup>a,b,\*</sup>

<sup>a</sup>*Univ. Bordeaux, LaBRI, UMR5800, F-33400 Talence*

<sup>b</sup>*CNRS, LaBRI, UMR5800, F-33400 Talence*

---

## Abstract

The *incidence coloring game* has been introduced in [S.D. Andres, The incidence game chromatic number, *Discrete Appl. Math.* 157 (2009), 1980–1987] as a variation of the ordinary coloring game. The incidence game chromatic number  $\iota_g(G)$  of a graph  $G$  is the minimum number of colors for which Alice has a winning strategy when playing the incidence coloring game on  $G$ .

In [C. Charpentier and É. Sopena, Incidence coloring game and arboricity of graphs, *Proc. IWOCA'2013, Lecture Notes Comput. Sci.* 8288 (2013), 106–114], we proved that  $\iota_g(G) \leq \lfloor \frac{3\Delta(G)-a}{2} \rfloor + 8a - 1$  for every graph  $G$  with arboricity at most  $a$ . In this paper, we extend our previous result to  $(a, d)$ -decomposable graphs – that is graphs whose set of edges can be partitioned into two parts, one inducing a graph with arboricity at most  $a$ , the other inducing a graph with maximum degree at most  $d$  – and prove that  $\iota_g(G) \leq \lfloor \frac{3\Delta(G)-a}{2} \rfloor + 8a + 3d - 1$  for every  $(a, d)$ -decomposable graph  $G$ .

*Keywords:* incidence coloring, incidence coloring game, incidence game chromatic number, arboricity,  $(a, d)$ -decomposable graphs

---

<sup>☆</sup>The results presented in this paper are an extension of a result presented at the conference IWOCA'2013, held in Rouen, France, from July 10<sup>th</sup> to 12<sup>th</sup>, 2013.

\*Corresponding author

*Email addresses:* `clement.charpentier@labri.fr` (C. Charpentier),  
`eric.sopena@labri.fr` (É. Sopena)

## 1. Introduction

All the graphs we consider are finite and undirected. For a graph  $G$ , we denote by  $V(G)$ ,  $E(G)$  and  $\Delta(G)$  its vertex set, edge set and maximum degree, respectively.

The *graph coloring game* on a graph  $G$  is a two-player game introduced by Brams [10] and rediscovered ten years later by Bodlaender [4]. Given a set of  $k$  colors, Alice and Bob take turns coloring properly an uncolored vertex of  $G$ , Alice having the first move. Alice wins the game if all the vertices of  $G$  are eventually colored, while Bob wins the game whenever, at some step of the game, all the colors appear in the neighborhood of some uncolored vertex. The *game chromatic number*  $\chi_g(G)$  of  $G$  is then the smallest  $k$  for which Alice has a winning strategy when playing the graph coloring game on  $G$  with  $k$  colors.

The problem of determining the game chromatic number of several graph classes has attracted great interest in recent years [17, 8, 12, 27, 23], with a particular focus on planar graphs [28, 16, 29] (see [3] for a comprehensive survey of this problem). In particular, Faigle *et al.* [9] proved that the game chromatic number of every forest is at most 4, and this bound is known to be tight [4].

An *incidence* of a graph  $G$  is a pair  $(v, e)$  where  $v$  is a vertex of  $G$  and  $e$  an edge incident to  $v$ . We denote by  $I(G)$  the set of incidences of  $G$ . Two incidences  $(v, e)$  and  $(w, f)$  are *adjacent* if either (1)  $v = w$ , (2)  $e = f$  or (3)  $vw = e$  or  $f$ . An *incidence coloring* of  $G$  is a coloring of its incidences in such a way that adjacent incidences get distinct colors. The smallest number of colors required for an incidence coloring of  $G$  is the *incidence chromatic number* of  $G$ , denoted by  $\chi_i(G)$ .

Incidence colorings have been introduced by Brualdi and Massey [6] in 1993. Upper bounds on the incidence chromatic number have been proven for various classes of graphs [6, 14, 15, 20, 25] (see [24] for an on-line survey). In particular, Brualdi and Massey proved that the incidence chromatic number of every forest  $F$  is at most  $\Delta(F) + 1$  and that this bound is tight [6].

In [2], Andres introduced the *incidence coloring game*, as the incidence version of the graph coloring game, each player, on his turn, coloring an uncolored incidence of  $G$  in a proper way. The *incidence game chromatic number*  $\iota_g(G)$  of a graph  $G$  is then defined as the smallest  $k$  for which Alice has a winning strategy when playing the incidence coloring game on  $G$  with  $k$  colors. Upper bounds on the incidence game chromatic number have been

proven for  $k$ -degenerate graphs [2] (a graph is  $k$ -degenerate if all its subgraphs have minimum degree at most  $k$ ), and exact values are known for cycles, stars [2], paths and wheels [18].

Andres observed that the inequalities  $\lceil \frac{3}{2}\Delta(G) \rceil \leq \iota_g(G) \leq 3\Delta(G) - 1$  hold for every graph  $G$  [2] and proved the following:

**Theorem 1** (Andres, [2]). *Let  $G$  be a  $k$ -degenerated graph. Then we have:*

- (i)  $\iota_g(G) \leq 2\Delta(G) + 4k - 2$ ,
- (ii)  $\iota_g(G) \leq 2\Delta(G) + 3k - 1$  if  $\Delta(G) \geq 5k - 1$ ,
- (iii)  $\iota_g(G) \leq \Delta(G) + 8k - 2$  if  $\Delta(G) \leq 5k - 1$ .

Since forests are 1-degenerate, outerplanar graphs are 2-degenerate and planar graphs are 5-degenerate, we get in particular that  $\iota_g(G) \leq 2\Delta(G) + 2$  whenever  $G$  is a forest,  $\iota_g(G) \leq 2\Delta(G) + 6$  whenever  $G$  is outerplanar and  $\iota_g(G) \leq 2\Delta(G) + 18$  whenever  $G$  is planar.

The arboricity  $a(G)$  of a graph  $G$  is the minimum number of forests into which its set of edges can be partitioned. In a companion paper [7], we proved the following:

**Theorem 2** (Charpentier and Sopena, [7]). *For every graph  $G$  with arboricity  $a(G) \leq a$ ,  $\iota_g(G) \leq \lfloor \frac{3\Delta(G)-a}{2} \rfloor + 8a - 1$ .*

Since for every graph  $G$ , we have  $a(G) = 1$  if  $G$  is a forest,  $a(G) \leq 2$  if  $G$  is an outerplanar graph and  $a(G) \leq 3$  if  $G$  is a planar graph (by Nash-Williams result [22]), we get the following corollary, which improves Theorem 1:

**Corollary 3.** *Let  $G$  be a graph,*

- (i) *If  $G$  is a forest, then  $\iota_g(G) \leq \lfloor \frac{3\Delta(G)}{2} \rfloor + 6$ .*
- (ii) *If  $G$  is an outerplanar graph, then  $\iota_g(G) \leq \lfloor \frac{3\Delta(G)}{2} \rfloor + 14$ .*
- (iii) *If  $G$  is a planar graph, then  $\iota_g(G) \leq \lfloor \frac{3\Delta(G)}{2} \rfloor + 21$ .*

In this paper, we extend our previous result to the case of  $(a, d)$ -decomposable graphs. A *decomposition* of a graph is a partition of its edges. We say that a graph  $G$  is  $(a, d)$ -decomposable if the set of edges of  $G$  can be partitioned into two subsets  $A$  and  $D$  in such a way that the graph  $G_a = (V(G), A)$  has arboricity at most  $a$  and the graph  $G_d = (V(G), D)$  has maximum degree at most  $d$ . We will prove the following:

**Theorem 4.** For every  $(a, d)$ -decomposable graph  $G$ ,  $\iota_g(G) \leq \lfloor \frac{3\Delta(G)-a}{2} \rfloor + 8a + 3d - 1$ .

Note that this theorem implies Theorem 2 when considering the case  $d = 0$ . Since  $\iota_g(G) \geq \lceil \frac{3\Delta(G)}{2} \rceil$  for every graph  $G$ , the difference between our upper bound and this lower bound only depends on the parameters  $a$  and  $d$ . Moreover, we can improve this general upper bound for graphs with large maximum degree:

**Theorem 5.** For every  $(a, d)$ -decomposable graph  $G$ , if  $\Delta(G) \geq 5a + 6d$  then  $\iota_g(G) \leq \lfloor \frac{3\Delta(G)-a}{2} \rfloor + 8a + d - 1$ .

These results are obtained using a refinement of the winning strategy proposed in [7]. Several authors have considered the problem of finding optimal  $(a, d)$ -decompositions of planar graphs of given girth (the *girth* of a graph  $G$  is the length of its shortest cycle) or without cycles of given length. The main results are summarized in the following:

**Theorem 6.** Let  $G$  be a planar graph with girth  $g$ . Then we have:

- (i)  $G$  is  $(2, 4)$ -decomposable (Gonçalves [11]).
- (ii) If  $g \geq 4$ , then  $G$  is  $(2, 0)$ -decomposable (Nash-Williams [22]).
- (iii) If  $G$  contains no 4-cycles, then  $G$  is  $(1, 5)$ -decomposable (Borodin et al. [5]).
- (iv) If  $g \geq 5$ , then  $G$  is  $(1, 4)$ -decomposable (He et al. [13]).
- (v) If  $g \geq 6$ , then  $G$  is  $(1, 2)$ -decomposable (Kleitman [19]).
- (vi) If  $g \geq 8$ , then  $G$  is  $(1, 1)$ -decomposable (Montassier [21]).
- (vii) If  $G$  is outerplanar, then  $G$  is  $(1, 3)$ -decomposable (Guan and Zhu [12]).

Using these results, we get the following upper bounds on the incidence game chromatic number:

**Corollary 7.** Let  $G$  be a planar graph with girth  $g$ . Then we have:

- (i) If  $\Delta(G) \geq 34$ , then  $\iota_g(G) \leq \lfloor \frac{3\Delta(G)}{2} \rfloor + 18$ .
- (ii) If  $g \geq 4$ , then  $\iota_g(G) \leq \lfloor \frac{3\Delta(G)}{2} \rfloor + 14$ .
- (iii) If  $G$  contains no 4-cycles and  $\Delta(G) \geq 35$ , then  $\iota_g(G) \leq \lfloor \frac{3\Delta(G)}{2} \rfloor + 11$ .
- (iv) If  $g \geq 5$ , then  $\iota_g(G) \leq \lfloor \frac{3\Delta(G)}{2} \rfloor + 18$  and, if  $\Delta(G) \geq 29$ , then  $\iota_g(G) \leq \lfloor \frac{3\Delta(G)}{2} \rfloor + 10$ .

- (v) If  $g \geq 6$ , then  $\iota_g(G) \leq \left\lceil \frac{3\Delta(G)}{2} \right\rceil + 12$  and, if  $\Delta(G) \geq 17$ , then  $\iota_g(G) \leq \left\lceil \frac{3\Delta(G)}{2} \right\rceil + 8$ .
- (vi) If  $g \geq 8$ , then  $\iota_g(G) \leq \left\lceil \frac{3\Delta(G)}{2} \right\rceil + 9$  and, if  $\Delta(G) \geq 11$ , then  $\iota_g(G) \leq \left\lceil \frac{3\Delta(G)}{2} \right\rceil + 7$ .
- (vii) If  $G$  is outerplanar, then  $\iota_g(G) \leq \left\lceil \frac{3\Delta(G)}{2} \right\rceil + 15$  and  $\Delta(G) \geq 23$ , then  $\iota_g(G) \leq \left\lceil \frac{3\Delta(G)}{2} \right\rceil + 9$ .

Note that this improves in particular Corollary 3 for outerplanar and planar graphs with high maximum degree.

Wang [26] considered  $(a, d)$ -decompositions of *NC-graphs*, that is, graphs embeddable in surfaces with nonnegative Euler characteristic (e.g. the Euclidian plane, the projective plane, the Klein bottle or the torus):

**Theorem 8** (Wang, [26]). *Let  $G$  be an NC-graph with girth  $g$ . Then we have:*

1. If  $g \geq 11$ , then  $G$  is  $(1, 1)$ -decomposable.
2. If  $g \geq 7$ , then  $G$  is  $(1, 2)$ -decomposable.
3. If either  $g \geq 5$  or  $G$  contains no 4- and 5-cycles, then  $G$  is  $(1, 4)$ -decomposable.
4. If  $G$  contains no 4-cycles, then  $G$  is  $(1, 6)$ -decomposable.

We thus get the following:

**Corollary 9.** *Let  $G$  be an NC-graph with girth  $g$ . Then we have:*

1. If  $g \geq 11$ , then  $\iota_g(G) \leq \left\lceil \frac{3\Delta(G)}{2} \right\rceil + 9$  and, if  $\Delta(G) \geq 11$ , then  $\iota_g(G) \leq \left\lceil \frac{3\Delta(G)}{2} \right\rceil + 7$ .
2. If  $g \geq 7$ , then  $\iota_g(G) \leq \left\lceil \frac{3\Delta(G)}{2} \right\rceil + 12$  and, if  $\Delta(G) \geq 17$ , then  $\iota_g(G) \leq \left\lceil \frac{3\Delta(G)}{2} \right\rceil + 8$ .
3. If either  $g(G) \geq 5$  or  $G$  contains no 4- and 5-cycles, then  $\iota_g(G) \leq \left\lceil \frac{3\Delta(G)}{2} \right\rceil + 18$  and, if  $\Delta(G) \geq 29$ , then  $\iota_g(G) \leq \left\lceil \frac{3\Delta(G)}{2} \right\rceil + 10$ .
4. If  $G$  contains no 4-cycles, then  $\iota_g(G) \leq \left\lceil \frac{3\Delta(G)}{2} \right\rceil + 24$  and, if  $\Delta(G) \geq 41$ , then  $\iota_g(G) \leq \left\lceil \frac{3\Delta(G)}{2} \right\rceil + 12$ .

In [1], Andres proved new upper bounds for the lightness of graphs embeddable on surfaces with positive or negative Euler characteristic. This allows to obtain new results on  $(a, d)$ -decompositions of such graphs and, therefore, new upper bounds for their incidence game chromatic number.

This paper is organised as follows. We introduce the necessary definitions and notation in Section 2, detail Alice’s strategy in Section 3 and prove Theorems 4 and 5 in Section 4.

## 2. Preliminaries

In this section we first give definitions and notations that will be used in the description of Alice’s strategy. Let  $G$  be an  $(a, d)$ -decomposable graph and  $E(G) = A \cup D$  be the associated *decomposition*. Moreover, let  $A = A_1 \cup \dots \cup A_a$  be a decomposition of  $A$  such that each  $A_i$ ,  $1 \leq i \leq a$ , induces a forest in  $G$ .

With  $G$ , we associate a mixed graph  $\vec{G} = (V(G), \vec{A}, D)$  obtained by giving an orientation to the edges of  $A$  as follows. For every tree  $T$  of every forest  $F_i = (V(G), A_i)$  in  $G$ , we arbitrarily choose any vertex of  $T$  as its root and orient all the edges of  $A_i$  from the root towards the leaves of  $T$ .

Let now  $(u, uv)$  be an incidence in  $G$ . We will say that  $(u, uv)$  is a *top-incidence* if  $u\vec{v} \in \vec{A}$ ,  $(u, uv)$  is a *down-incidence* if  $v\vec{u} \in \vec{A}$ , and  $(u, uv)$  is a *medium-incidence* if  $uv \in D$ .

Since in every forest  $F_i = (V(G), A_i)$  every vertex is incident to at most one down-incidence, we easily get the following:

**Observation 10.** *Every vertex in an  $(a, d)$ -decomposable graph is incident to at most  $a$  down-incidences.*

We will sometimes slightly abuse the notation and denote a top-incidence by  $(u, u\vec{v})$ , a down-incidence by  $(u, v\vec{u})$  and a medium-incidence by  $(u, \overline{uv})$  or  $(u, \overline{vu})$  (the notation  $\overline{uv}$  being thus reserved for the edges belonging to  $D$ ).

If  $uv$  is an edge in  $G$  such that  $u\vec{v} \in \vec{A}$ , then  $top(uv)$  denotes the top-incidence  $(u, u\vec{v})$  of  $uv$  and  $down(uv)$  denotes the down-incidence  $(v, v\vec{u})$  of  $uv$ . Moreover, for every incidence  $i = (u, uv)$  in  $G$  with  $uv \in A$ , we let  $top(i) = top(uv)$  and  $down(i) = down(uv)$ .

We now give some notation and terminology concerning the different types of incidences that may “surround” a given incidence  $i$  in  $G$ . These definitions are illustrated in Figures 1, 2 and 3 depending on whether the

considered incidence  $i$  is a top-, down- or medium-incidence, respectively. In these figures, every edge from the set  $A$  is drawn as an arc (corresponding to its orientation in  $\vec{A}$ ) and each edge of  $D$  as a dashed edge. Top-incidences are drawn as white squares, down-incidences as black squares and medium-incidences as grey squares. Note also that some vertices represented as distinct vertices may be identified but that this does not change the associated sets of incidences.

**Definition 11** (Sons). We denote by  $tS(i)$ ,  $dS(i)$  and  $mS(i)$  the set of *top-sons*, *down-sons* and *medium-sons*, respectively, of an incidence  $i$ , defined by

$$\begin{aligned} tS(u, \vec{uv}) &= tS(v, \vec{uv}) = tS(u, \overline{uv}) = \{top(v\vec{w}) \mid v\vec{w} \in \vec{A}\}, \\ dS(u, \vec{uv}) &= dS(v, \vec{uv}) = dS(u, \overline{uv}) = \{down(v\vec{w}) \mid v\vec{w} \in \vec{A}\}, \\ mS(u, \vec{uv}) &= mS(v, \vec{uv}) = \{(v, \overline{uv}) \mid \overline{uv} \in D\}, \quad mS(u, \overline{uv}) = \emptyset. \end{aligned}$$

Moreover, we denote by  $S(i)$  the set of *sons* of  $i$ , that is  $S(i) = tS(i) \cup dS(i) \cup mS(i)$ .

**Definition 12** (Fathers). We denote by  $tF(i)$ ,  $dF(i)$  and  $mF(i)$  the set of *top-fathers*, *down-fathers* and *medium-fathers*, respectively, of an incidence  $i$ , defined by

$$\begin{aligned} tF(u, \vec{uv}) &= tF(v, \vec{uv}) = tF(u, \overline{uv}) = \{top(\vec{w}u) \mid \vec{w}u \in \vec{A}, w \neq v\}, \\ dF(u, \vec{uv}) &= dF(v, \vec{uv}) = dF(u, \overline{uv}) = \{down(\vec{w}u) \mid \vec{w}u \in \vec{A}, w \neq v\}, \\ mF(u, \vec{uv}) &= mF(v, \vec{uv}) = \{(u, \overline{uv}) \mid \overline{uv} \in D\}, \quad mF(u, \overline{uv}) = \emptyset. \end{aligned}$$

Moreover, we denote by  $F(i)$  the set of *fathers* of  $i$ , that is  $F(i) = tF(i) \cup dF(i) \cup mF(i)$ .

**Definition 13** (Brothers). We denote by  $tB(i)$  and  $dB(i)$  the set of *top-brothers* and *down-brothers*, respectively, of a top- or down- incidence  $i$ , defined by

$$\begin{aligned} tB(u, \vec{uv}) &= tB(v, \vec{uv}) = \{top(\vec{u}\vec{w}) \mid \vec{u}\vec{w} \in \vec{A}, top(\vec{u}\vec{w}) \neq i\}, \\ dB(u, \vec{uv}) &= dB(v, \vec{uv}) = \{down(\vec{u}\vec{w}) \mid \vec{u}\vec{w} \in \vec{A}, down(\vec{u}\vec{w}) \neq i\}. \end{aligned}$$

Moreover, we denote by  $B(i)$  the set of *brothers* of a top- or down-incidence  $i$ , that is  $B(i) = tB(i) \cup dB(i)$ , or the set of brothers of a medium-incidence  $i$ , defined in that case by

$$B(u, \overline{uv}) = \{(u, \overline{uv}) \mid \overline{uv} \in D, w \neq v\}.$$

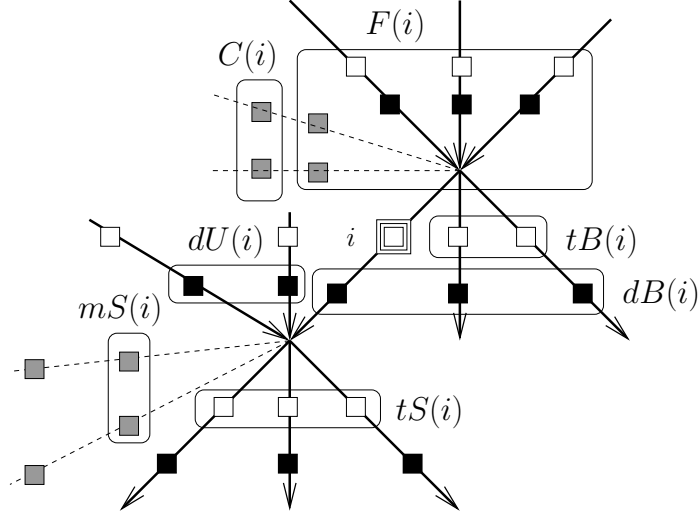

Figure 1: Incidences surrounding a top-incidence  $i$ .

**Definition 14** (Uncles). We denote by  $tU(i)$  and  $dU(i)$  the set of *top-uncles* and *down-uncles*, respectively, of a top- or down-incidence  $i$ , defined by

$$tU(u, \vec{wv}) = tB(v, \vec{wv}) = \{\text{top}(\vec{wv}) \mid \vec{wv} \in \vec{A}, w \neq u\},$$

$$dU(u, \vec{wv}) = dB(v, \vec{wv}) = \{\text{down}(\vec{wv}) \mid \vec{wv} \in \vec{A}, w \neq u\}.$$

Moreover, we denote by  $U(i)$  the set of *uncles* of a top- or down-incidence  $i$ , that is  $U(i) = tU(i) \cup dU(i)$ . (Observe that an “uncle” of  $i$  here is not a brother of a father of  $i$  but another father of the sons of  $i$ .)

**Definition 15** (Nephews). We denote by  $tN(i)$ ,  $dN(i)$  and  $mN(i)$  the set of *top-nephews*, *down-nephews* and *medium-nephews*, respectively, of a medium-incidence  $i$ , defined by

$$tN(u, \vec{wv}) = \{(v, \vec{wv}) \mid \vec{wv} \in \vec{A}\},$$

$$dN(u, \vec{wv}) = \{(w, \vec{wv}) \mid \vec{wv} \in \vec{A}\},$$

$$mN(u, \vec{wv}) = \{(v, \vec{wv}) \mid \vec{wv} \in D, w \neq u\}.$$

Moreover, we denote by  $N(i)$  the set of *nephews* of a medium-incidence  $i$ , that is  $N(i) = tN(i) \cup dN(i) \cup mN(i)$ .



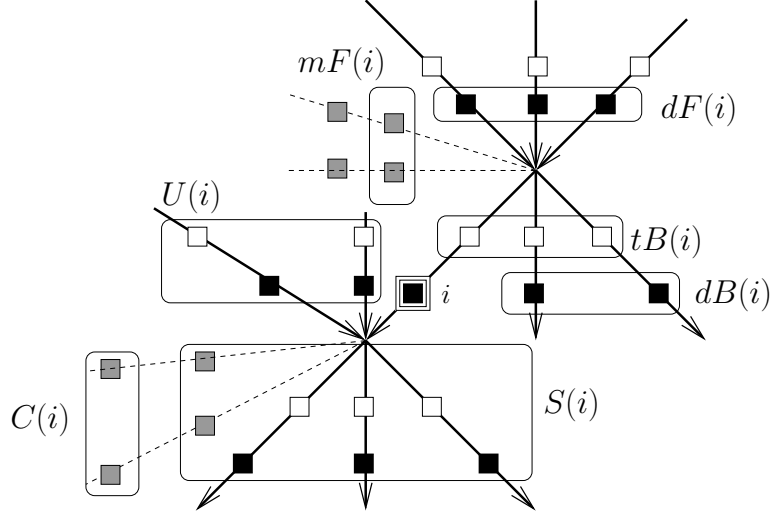

Figure 2: Incidences surrounding a down-incidence  $i$ .

**Definition 16** (Cousins). We denote by  $C(i)$  the set of *cousins* of an incidence  $i$ , defined by

$$C(u, \vec{wv}) = C(u, \overline{wv}) = \{(w, \overline{wu}) \mid \overline{wu} \in D\}, \quad C(v, \vec{wv}) = \{(w, \overline{wv}) \mid \overline{wv} \in D\}.$$

(Observe that if  $i$  is a top-incidence, then every cousin of  $i$  shares its edge with a medium-father of  $i$ ; if  $i$  is a down-incidence, then every cousin of  $i$  shares its edge with a medium-son of  $i$ ; and if  $i$  is a medium-incidence, then every cousin of  $i$  shares its edge either with  $i$  itself or with a brother of  $i$ .)

From the above definitions, we directly get the following:

**Observation 17.** For every  $(a, d)$ -decomposable graph  $G$ , the following statements hold:

- (i) Every incidence  $i$  has at most  $a$  top-fathers, as many down-fathers as top-fathers, and at most  $d$  medium-fathers.
- (ii) Every incidence  $i$  has at most  $\Delta(G) - 1$  top- or medium-sons (among which at most  $d$  medium-sons), and as many down-sons as top-sons.
- (iii) Every top-incidence  $i$  has at most  $\Delta(G) - |tF(i)| - |mF(i)| - 1$  top-brothers and at most  $\Delta(G) - |tF(i)| - |mF(i)|$  down-brothers.
- (iv) Every down-incidence  $i$  has at most  $\Delta(G) - |tF(i)| - |mF(i)|$  top-brothers and at most  $\Delta(G) - |tF(i)| - |mF(i)| - 1$  down-brothers.

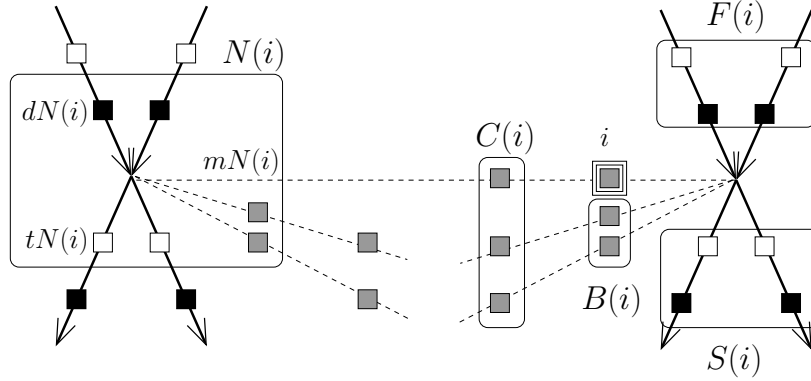

Figure 3: Incidences surrounding a medium-incidence  $i$ .

- (v) Every medium-incidence  $i$  has at most  $d - 1$  brothers.
- (vi) Every top- or down-incidence  $i$  has at most  $a - 1$  top-uncles and as many down-uncles as top-uncles.
- (vii) Every incidence  $i$  has at most  $d$  cousins.
- (viii) For every top- or down-incidence  $i$ ,  $|dU(i)| + |mS(i)| + |tS(i)| \leq \Delta(G) - 1$ .

### 3. Alice's strategy

We now turn to the description of Alice's strategy which will allow her to win the incidence coloring game on an  $(a, d)$ -decomposable graph  $G$  whenever the number of available colors is at least  $\lfloor \frac{3\Delta(G)-a}{2} \rfloor + 8a + 3d - 1$ . This strategy is an extension of the strategy introduced in [7] and uses the concept of *activation strategy* [3], often used in the context of the ordinary graph coloring game.

During the game, each uncolored incidence may be either *active* (if Alice activated it) or *inactive*. When the game starts, every incidence is inactive. When an active incidence is colored, it is no longer considered as active. For each set  $I$  of incidences, we will denote by  $I_c$  the set of colored incidences of  $I$  and by  $I_a$  the set of active incidences of  $I$  ( $I_c$  and  $I_a$  are therefore disjoint for every set of incidences  $I$ ).

An incidence  $i$  of  $G$  is said to be *neutral* if  $i$  is neither active nor colored and either

- (i)  $i$  is a down-incidence and all the incidences of  $dF(i)$  are colored, or
- (ii)  $i$  is a medium-incidence and all the incidences of  $F(i)$  are colored, or
- (iii)  $i$  is a top incidence and all the incidences of  $F(i) \cup C(i)$  are colored.

We denote by  $\Phi$  the set of colors used for the game, by  $\phi(i)$  the color of an incidence  $i$  and, for each set  $I$  of incidences, we let  $\phi(I) = \bigcup_{i \in I} \phi(i)$ .

Our objective is to bound the cardinality of the sets of *forbidden colors* of every uncolored incidence  $i$  which, as shown by Figures 1, 2 and 3, are given by:

- $Forb(i) = \phi(F(i) \cup B(i) \cup tS(i) \cup mS(i) \cup dU(i) \cup C(i))$  if  $i$  is a top-incidence,
- $Forb(i) = \phi(F(i) \cup B(i) \cup S(i) \cup C(i) \cup N(i))$  if  $i$  is a medium-incidence,
- $Forb(i) = \phi(dF(i) \cup mF(i) \cup tB(i) \cup S(i) \cup U(i) \cup C(i))$  if  $i$  is a down-incidence.

For every incidence  $i$ , an *available color for  $i$*  is any color from  $\Phi \setminus Forb(i)$ .

If, at some point of the game, the graph  $G$  contains no active incidence and no neutral incidence, then Alice may make what we call a *neutral move*, explained below. Let  $i_0$  be an incidence which is neither colored, active or neutral and let  $i_1$  be the incidence defined as follows:

- If  $dF(i_0)$  contains an uncolored incidence  $i$ , then we let  $i_1 = i$ .
- If all the incidences in  $dF(i_0)$  are colored then, since  $i_0$  is not a neutral incidence,  $i_0$  cannot be a down-incidence. If  $tF(i_0)$  contains an uncolored incidence  $i$ , then we let  $i_1 = i$ .
- If all the incidences of  $dF(i_0) \cup tF(i_0)$  are colored and  $mF(i_0)$  contains an uncolored incidence  $i$ , then we let  $i_1 = i$ .
- If all the incidences of  $F(i_0) = dF(i_0) \cup tF(i_0) \cup mF(i_0)$  are colored then, since  $i_0$  is not a neutral incidence,  $i_0$  must be a top-incidence and  $C(i_0)$  must contain an uncolored incidence  $i$ . We then let  $i_1 = i$ .

Similarly, we define the incidence  $i_2$  starting from  $i_1$ , the incidence  $i_3$  starting from  $i_2$  and so on, until we reach an incidence  $i_k$  already encountered, that is  $i_k = i_\ell$  for some  $\ell < k$ . We thus construct a “loop” of incidences

$$(i_k = i_\ell, i_{\ell+1}, \dots, i_k),$$

such that each incidence in the loop is a father or a cousin of the previous incidence. A neutral move then consists in arbitrarily choosing any incidence in this loop, coloring it and activating all other incidences of the loop.

Alice's strategy uses four rules. The first three rules, (R1), (R2) and (R3) below, determine which incidence Alice colors at each move. The fourth rule explains which color she will use when she colors the chosen incidence.

(R1) Alice's first move.

- If there is some neutral incidence  $i$ , then Alice colors the incidence  $i$ .
- Otherwise, Alice makes a neutral move.

(R2) If Bob, on his turn, colored a neutral incidence  $i$  then:

- if  $i$  is a down-incidence and  $dB(i)$  contains an uncolored incidence  $j$  then Alice colors  $j$ . (Note that  $j$  also is a neutral incidence.)
- Otherwise, if there is a neutral incidence  $j$  in  $G$  then Alice colors  $j$ .
- Otherwise, Alice makes a neutral move.

(R3) If Bob, on his turn, colored a incidence  $i$  which is not neutral then Alice *climbs*  $i$ . Climbing an incidence  $i$  is a recursive procedure described as follows:

- (R3.1) If  $i$  is an active incidence (thus uncolored) then Alice colors  $i$ .
- (R3.2) If  $i$  is a neutral incidence (thus uncolored) then Alice colors  $i$ .  
Otherwise, Alice activates the incidence  $i$  if  $i$  is uncolored and:
  - (R3.2.1) If  $i$  has an uncolored down-father  $j$ , then Alice climbs  $j$ .
  - (R3.2.2) If all the down-fathers of  $i$  are colored, then  $i$  is either a medium- or a top-incidence. If  $i$  has an uncolored top-father  $j$ , then Alice climbs  $j$ .
  - (R3.2.3) If all the top- and down-fathers of  $i$  are colored, then  $i$  is a top-incidence. If  $i$  has an uncolored medium-father  $j$ , then Alice climbs  $j$ .
  - (R3.2.4) If all the fathers of  $i$  are colored, then  $i$  is a top-incidence and has an uncolored cousin  $j$ . Alice then climbs  $j$ .

(R4) When Alice colors an incidence  $i$ , she chooses the color of  $i$  as follows:

- If  $i$  is a down-incidence and  $|\phi(dB(i))| \geq 4a + d - 1$ , she chooses an available color from  $\phi(dB(i))$ . (We will show in Lemma 23 that this is always possible.)
- Otherwise, she chooses any available color. (We will prove that this is always possible.)

Observe that the “loop” of incidences we used when defining a neutral move was in fact obtained by successively climbing the encountered incidences. When Alice makes a neutral move, each incidence of the loop is thus climbed once.

From the above-defined set of rules, we easily get the following:

**Observation 18.** *Let  $i$  be an uncolored incidence. If  $i$  is inactive and climbed by Alice, then  $i$  is activated or colored (by Rule R3.2 or by a neutral move). If  $i$  is active and climbed by Alice, then  $i$  is colored (by Rule R3.1). Therefore, every incidence is climbed at most twice by Alice.*

**Observation 19.** *Except when she makes a neutral move, Alice only colors neutral or activated incidences.*

**Observation 20.** *Let  $j$  be a non-neutral incidence about to be colored. If  $j$  is colored by Bob, then Alice replies by climbing  $j$  (Rule R3). If  $j$  is colored by Alice, then either Alice is making a neutral move, and thus climbs  $j$ , or  $j$  is an active incidence by Observation 19 and thus has been previously climbed by Alice.*

Before we start with the technical details proving the correctness of this strategy, we give some intuition about how this strategy works. For an incidence  $i$ , Alice aims to bound the number of its adjacent sons colored before  $i$ , as activation strategies usually do (this is the role of the three first rules). The main breakthrough made in [7], compared to previous strategies, is to bound, for any brotherhood of down-incidences, the number of different colors used to color them (thanks to rule R4). As we will see, when the number of down-incidences colored in the same brotherhood is large enough, the strategy ensures that several of these incidences were colored by Alice, and that Alice was able to color them with a color already used in this neighbourhood. Finally, the main difference between this strategy and the one given in [7] is that we have to care about the medium incidences, which add a whole layer of technical details and minor improvements.

#### 4. Proof of Theorems 4 and 5

We now prove a series of lemmas from which the proofs of Theorem 4 and Theorem 5 will follow.

**Lemma 21.** *If Alice or Bob is about to color a down-incidence  $i$ , then*

$$|S_c(i)| + |U_c(i)| \leq 4a - 2. \quad (1)$$

*If Alice or Bob is about to color a medium-incidence  $i$ , then*

$$|tS_c(i)| \leq 4a + d. \quad (2)$$

*If Alice or Bob is about to color a top-incidence  $i$ , then*

$$|tS_c(i)| + |mS_c(i)| \leq 4a. \quad (3)$$

*Proof.* Let  $i$  be a down-incidence about to be colored by Alice or Bob. If  $|S_c(i)| = 0$ , then  $|S_c(i)| + |U_c(i)| = |U_c(i)| \leq |U(i)| \leq 2a - 2$  by Observation 17. Otherwise, let  $j$  be an incidence of  $S_c(i)$  which was colored before  $i$ . When  $j$  was colored,  $j$  was not a neutral incidence since  $i$  (a father of  $j$ ) was not yet colored. Hence, whoever player colored  $j$ ,  $j$  has been climbed by Alice by Observation 20. When Alice has climbed  $j$  for the first time, she has then climbed either  $i$  or an uncolored incidence of  $dU(i)$  by Rule R3.2.1 or by a neutral move. By Observation 18, every incidence is climbed at most twice and, therefore,  $|S_c(i)| \leq 2 \times (|dU(i)| + 1)$ . Since  $|dU(i)| \leq a - 1$  by Observation 17, we have  $|S_c(i)| \leq 2a$ . Therefore, since  $|U_c(i)| \leq |U(i)| \leq 2a - 2$ , Equation (1) holds.

Let now  $i$  be a medium-incidence about to be colored by Alice or Bob. If  $|tS_c(i)| = 0$ , then Equation (2) obviously holds. Otherwise, let  $j$  be an incidence of  $tS_c(i)$  which was colored before  $i$ . As before, when  $j$  was colored,  $j$  was not a neutral incidence since  $i$  (a father of  $j$ ) was not yet colored. Hence, by Observation 20,  $j$  has been climbed by Alice. When Alice has climbed  $j$  for the first time,

- either Alice has climbed an uncolored incidence of  $dF(i)$  or  $tF(i)$  by Rule R3.2.1, Rule R3.2.2 or by a neutral move,
- or all the incidences of  $dF(i)$  and  $tF(i)$  were already colored, and there is at least an uncolored incidence in  $mF(j) = \{i\} \cup B(i)$ . All the incidences of  $mF(j)$  have the same fathers, namely the incidences of

$dF(i) \cup tF(i)$ . Since their fathers are all colored, the incidences of  $mF(j)$  are all neutral by definition. Alice has thus climbed an incidence of  $mF(j)$  by Rule R3.2.3, and then colored this incidence by Rule R3.2.5.

Hence, by Observation 18, we have  $|tS_c(i)| \leq 2|F(i)| + |B(i)| + 1$ . Since  $|F(i)| \leq 2a$  and  $|B(i)| \leq d - 1$  by Observation 17, Equation (2) also holds.

Finally, let  $i$  be a top-incidence about to be colored by Alice or Bob. If  $|tS_c(i)| + |mS_c(i)| = 0$ , then Equation (3) obviously holds. Otherwise, let  $j$  be an incidence of  $tS_c(i)$  or  $mS_c(i)$  which was colored before  $i$ . Again, when  $j$  was colored,  $j$  was not a neutral incidence since  $i$  (a father of  $j$ ) was not yet colored. Hence, by Observation 20,  $j$  has been climbed by Alice. When Alice has climbed  $j$  for the first time, she also climbed  $i$ ,  $down(i)$  or an incidence of  $U(i)$ . We then have  $|tS_c(i)| + |mS_c(i)| \leq 2 \times (|U(i)| + 2) \leq 4a$  by Observation 17, and Equation (3) holds.  $\square$

**Lemma 22.** *If Alice or Bob is about to color a medium-incidence  $i$ , then  $|N_c(i)| \leq 5a + 4d - 1$ .*

*Proof.* Let  $i$  be a medium-incidence about to be colored by Alice or Bob. We have  $|dN_c(i)| \leq |dN(i)| \leq a$  and  $|mN_c(i)| \leq |mN(i)| \leq d - 1$  by Observation 17. The proof for getting an upper bound of  $|tN_c(i)|$  is then similar to the proof of Equation (2) in Lemma 21. Observe first that the incidences of  $dN(i)$  are the fathers of the incidences of  $tN_c(i)$ , and that  $i$  is a cousin of the incidences of  $tN(i)$ .

If  $|tN_c(i)| = 0$  the result is obviously true. Otherwise, let  $j$  be an incidence of  $tN_c(i)$  which was previously colored. When  $j$  was colored,  $j$  was not a neutral incidence since one of its cousins, namely  $i$ , was not colored yet. Hence, by Observation 20,  $j$  was climbed by Alice. When Alice has climbed  $j$  for the first time,

- either Alice has climbed an uncolored incidence of  $dF(j) = dN(i)$  or  $tF(j)$  by Rule R3.2.1, Rule R3.2.2 or by a neutral move,
- or all the incidences of  $dF(j)$  and  $tF(j)$  were colored, implying that the incidences of  $mF(j)$  were neutral incidences; Alice has thus climbed an incidence of  $mF(j)$  by Rule R3.2.3 and has colored this neutral incidence right after by Rule R3.2.
- or all the incidences of  $F(j)$  were colored, and Alice has climbed an incidence of  $C(j)$  by Rule R3.2.4.

We thus have by Observation 17  $|tN_c(i)| \leq 2 \times (|tF(j)| + |dF(j)| + |C(j)|) + |mF(j)| \leq 2 \times (a + a + d) + d = 4a + 3d$ , so that  $|N_c(i)| = |tN_c(i)| + |dN_c(i)| + |mN_c(i)| \leq 4a + 3d + a + d - 1 = 5a + 4d - 1$  and the result follows.  $\square$

**Lemma 23.** *When Alice or Bob is about to color a down-incidence  $i$  there exists an available color for  $i$  whenever  $|\Phi| \geq \Delta(G) + 4a + d - 1$ . Moreover, if  $|\phi(dB(i))| \geq 4a + d - 1$ , then there is an available color for  $i$  in  $\phi(dB(i))$ .*

*Proof.* Recall that the set of forbidden colors, since  $i$  is a down-incidence, is

$$\text{Forb}(i) = \phi(dF(i)) \cup \phi(mF(i)) \cup \phi(tB(i)) \cup \phi(S(i)) \cup \phi(U(i)) \cup \phi(C(i)).$$

Note also that we have:

- $|dF(i)| + |mF(i)| + |tB(i)| \leq \Delta(G)$  since  $i$  is a down-incidence,
- $|S_c(i)| + |U_c(i)| \leq 4a - 2$  by Lemma 21,
- $|C(i)| \leq d$ .

Hence, there is an available color for  $i$  in  $\Phi$  whenever  $|\Phi| \geq \Delta(G) + 4a + d - 1$ .

Moreover, the colors of  $\phi(dF(i))$ ,  $\phi(mF(i))$  and  $\phi(tB(i))$  are all distinct from the colors of  $\phi(dB(i))$ , so that there are at most  $4a + d - 2$  colors forbidden for  $i$  in  $\phi(dB(i))$ , which concludes the proof.  $\square$

**Lemma 24.** *If  $i$  is a top-incidence, then  $|\phi(dB(i))| \leq 4a + d - 1$  or  $|\phi(dB(i))| \leq \left\lceil \frac{|dB(i)| + d}{2} \right\rceil + 2a$ .*

*Proof.* Let  $i$  be a top-incidence such that  $|\phi(dB(i))| > 4a + d - 1$ . At some step in the game,  $|\phi(dB(i))|$  reached the value  $4a + d - 1$ . At that time, at least  $4a + d - 1$  incidences  $dB(i)$  are colored. By Lemma 21, each time a down-incidence  $j$  is about to be colored, we have  $|S_c(j)| + |U_c(j)| \leq 4a - 2$ , and thus  $|S_c(j)| \leq 4a + d - 2$ . Hence, the down-fathers of  $i$  were already colored when  $|\phi(dB(i))|$  reached the value  $4a + d - 1$ , implying all uncolored incidences of  $dB(i)$  were neutral from that moment.

Thus, during the rest of the game, each time Bob colors an incidence of  $dB(i)$ , Alice also colors an incidence of  $dB(i)$  by Rule R2 if there is an uncolored one. So, among the  $|dB(i)| - (4a - d - 1)$  remaining uncolored incidences, Bob will color at most  $\left\lceil \frac{|dB(i)| - (4a - d - 1)}{2} \right\rceil$  of them. We know by



Rule R4 and Lemma 23 that when Alice colors an incidence of  $dB(i)$  with  $|\phi(dB(i))| > 4a + d - 1$ , she chooses a color in  $\phi(dB(i))$ . We thus have

$$|\phi(dB(i))| \leq 4a + d - 1 + \left\lceil \frac{|dB(i)| - (4a + d - 1)}{2} \right\rceil = \left\lfloor \frac{|dB(i)| + d}{2} \right\rfloor + 2a$$

and the result follows.  $\square$

**Corollary 25.** *If  $i$  is a medium-incidence, then  $|\phi(dS(i))| \leq 4a + d - 1$  or  $|\phi(dS(i))| \leq \left\lfloor \frac{|dS(i)| + d}{2} \right\rfloor + 2a$ .*

*Proof.* Let  $i$  be a medium-incidence having at least one down-son. Clearly  $i$  has then at least one top-son, say  $j$ . We thus have  $dS(i) = dB(j)$  and the result follows from Lemma 24.  $\square$

**Lemma 26.** *When Alice or Bob is about to color a top-incidence  $i$ , there is an available color for  $i$  whenever  $|\Phi| \geq \left\lfloor \frac{3\Delta(G) - a}{2} \right\rfloor + 8a + d - 1$ .*

*Proof.* Assume that  $|\Phi| \geq \left\lfloor \frac{3\Delta(G) - a}{2} \right\rfloor + 8a + d - 1$  and let  $i$  be an uncolored top-incidence. Recall that the set of forbidden colors for  $i$  is

$$\text{Forb}(i) = \phi(F(i) \cup B(i) \cup tS(i) \cup mS(i) \cup dU(i) \cup C(i)).$$

Note also that we have :

- $|dF(i)| + |mF(i)| + |tB(i)| \leq \Delta(G) - 1$ ,
- $|tS_c(i)| + |mS_c(i)| \leq 4a$  by Lemma 21,
- $|dU(i)| \leq a - 1$ ,
- $|tF(i)| \leq a$ ,
- $|C(i)| \leq d$ ,
- $|tF(i)| + |C(i)| + |dB(i)| \leq \Delta(G)$ ,
- $|\phi(dB(i))| \leq 4a + d - 1$  or  $|\phi(dB(i))| \leq \left\lfloor \frac{|dB(i)| + d}{2} \right\rfloor + 2a$  by Lemma 24.

We can thus find an upper bound for the cardinality of  $Forb(i)$  as follows:

$$|Forb(i)| \leq \Delta(G) + 5a - 2 + (|\phi(tF(i))| + |\phi(C(i))| + |\phi(dB(i))|) \quad (4)$$

$$|Forb(i)| \leq 2\Delta(G) + 5a - 2 \quad (5)$$

We now consider three cases.

Case 1.  $\left\lfloor \frac{\Delta(G)+a}{2} \right\rfloor \leq 3a + d.$

Note that we have:

$$\left\lfloor \frac{\Delta(G) + a}{2} \right\rfloor = \Delta(G) - \left\lfloor \frac{\Delta(G) - a}{2} \right\rfloor \leq 3a + d$$

$$\Delta(G) \leq \left\lfloor \frac{\Delta(G) - a}{2} \right\rfloor + 3a + d$$

$$2\Delta(G) \leq \left\lfloor \frac{3\Delta(G) - a}{2} \right\rfloor + 3a + d$$

$$2\Delta(G) + 5a - 2 \leq \left\lfloor \frac{3\Delta(G) - a}{2} \right\rfloor + 8a + d - 2$$

By (5), we thus have at least one available color for  $i$ .

Case 2.  $|\phi(dB(i))| \leq \left\lfloor \frac{|dB(i)|+d}{2} \right\rfloor + 2a.$

Since there are at most

$$\Delta(G) + 5a - 2 + (|\phi(tF(i))| + |\phi(C(i))| + |\phi(dB(i))|)$$

forbidden colors for  $i$  by (4), and since

$$|tF(i)| + |dB(i)| + |C(i)| \leq \Delta(G),$$

the number of forbidden colors for  $i$  is bounded as follows:

$$\begin{aligned} |Forb(i)| &\leq \Delta(G) + 5a - 2 + |tF(i)| + |C(i)| + \left\lfloor \frac{|dB(i)| + d}{2} \right\rfloor + 2a \\ &\leq \Delta(G) + 5a - 2 + |tF(i)| + |C(i)| + \left\lfloor \frac{\Delta(G) - |tF(i)| - |C(i)| + d}{2} \right\rfloor + 2a. \end{aligned}$$

The value of this expression increases when  $|tF(i)|$  or  $|C(i)|$  increases, and thus

$$|Forb(i)| \leq \Delta(G) + 5a - 2 + a + d + \left\lfloor \frac{\Delta(G) - a - d + d}{2} \right\rfloor + 2a$$

$$= \left\lfloor \frac{3\Delta(G) - a}{2} \right\rfloor + 8a + d - 2.$$

Hence we have at least one available color for  $i$ .

Case 3.  $\left\lceil \frac{\Delta(G)+a}{2} \right\rceil > 3a + d$  and  $|\phi(dB(i))| \leq 4a + d - 1$ .

By (4), there are at most

$$\Delta(G) + 5a - 2 + (|\phi(tF(i))| + |\phi(C(i))| + |\phi(dB(i))|) \leq \Delta(G) + 10a + 2d - 3$$

forbidden colors for  $i$ . Since

$$\begin{aligned} \left\lceil \frac{\Delta(G) + a}{2} \right\rceil &> 3a + d \\ \Rightarrow \left\lfloor \frac{\Delta(G) - a}{2} \right\rfloor &\geq 2a + d \\ \Rightarrow \left\lfloor \frac{3\Delta(G) - a}{2} \right\rfloor &\geq \Delta(G) + 2a + d \end{aligned}$$

We get

$$\left\lfloor \frac{3\Delta(G) - a}{2} \right\rfloor + 8a + d - 3 \geq \Delta(G) + 10a + 2d - 3$$

and thus we have at least one available color for  $i$ .

□

**Lemma 27.** *When Alice or Bob is about to color a medium-incidence  $i$ , there is an available color for  $i$  whenever  $|\Phi| \geq \left\lfloor \frac{3\Delta(G)-a}{2} \right\rfloor + 8a + 3d - 1$  or  $|\Phi| \geq \left\lfloor \frac{\Delta(G)-a}{2} \right\rfloor + 13a + 7d - 1$ .*

*Proof.* Recall that the set of forbidden colors for the medium-incidence  $i$  is

$$Forb(i) = \phi(F(i) \cup B(i) \cup S(i) \cup C(i) \cup N(i))$$

Note also that we have:

- $|tF(i)| = |dF(i)| \leq a$ ,
- $|C(i)| \leq d$ ,

- $|B(i)| \leq d - 1$ ,
- $|tS_c(i)| \leq 4a + d$  by Lemma 21,
- $|dS(i)| + |C(i)| + |dF(i)| \leq \Delta(G)$ ,
- $|tS(i)| + |B(i)| + |tF(i)| \leq \Delta(G) - 1$ ,
- $|\phi(dS(i))| \leq 4a + d - 1$  or  $|\phi(dS(i))| \leq \left\lfloor \frac{|dS(i)|+d}{2} \right\rfloor + 2a$  by Corollary 25.

We then have

$$|Forb(i)| \leq \Delta(G) + \Delta(G) - 1 + |N_c(i)| = 2\Delta(G) - 1 + |N_c(i)| \quad (6)$$

and also

$$|Forb(i)| \leq |\phi(dS(i))| + |C(i)| + |dF(i)| + 5a + 2d - 1 + |N_c(i)| \quad (7)$$

and thus

$$|Forb(i)| \leq |\phi(dS(i))| + 6a + 3d - 1 + |N_c(i)|. \quad (8)$$

We first prove that the incidence  $i$  has at most  $\left\lfloor \frac{\Delta(G)-a}{2} \right\rfloor + 8a + 3d - 1 + |N_c(i)|$  forbidden colors. We consider three cases.

Case 1.  $\left\lfloor \frac{\Delta(G)-a}{2} \right\rfloor < 2a + d - 1$ .

We then have  $\Delta(G) - a \leq 2 \times (2a + d - 1)$  and  $\Delta(G) \leq 5a + 2d - 2$ . By (6), there are at most  $2\Delta(G) - 1 + |N_c(i)|$  forbidden colors for  $i$  and we have:

$$\begin{aligned} \left\lfloor \frac{\Delta(G) - a}{2} \right\rfloor &< 2a + d - 1 \\ \left\lfloor \frac{\Delta(G) - a}{2} \right\rfloor + \left\lfloor \frac{\Delta(G) - a}{2} \right\rfloor &< \left\lfloor \frac{\Delta(G) - a}{2} \right\rfloor + 2a + d - 1 \\ \Delta(G) - a &\leq \left\lfloor \frac{\Delta(G) - a}{2} \right\rfloor + 2a + d - 1 \\ 2\Delta(G) - a &\leq \left\lfloor \frac{\Delta(G) - a}{2} \right\rfloor + 7a + 3d - 3 \\ 2\Delta(G) - 1 + |N_c(i)| &\leq \left\lfloor \frac{\Delta(G) - a}{2} \right\rfloor + 8a + 3d - 4 + |N_c(i)| \end{aligned}$$

as required.

Case 2.  $|\phi(dS(i))| \leq \left\lfloor \frac{|dS(i)|+d}{2} \right\rfloor + 2a$ .

Since there are at most

$$|\phi(dS(i))| + |C(i)| + |dF(i)| + 5a + 2d - 1 + |N_c(i)|$$

forbidden colors for  $i$  by (7) and, since

$$|dS(i)| + |C(i)| + |dF(i)| \leq \Delta(G),$$

the number of forbidden colors for  $i$  is at most

$$\begin{aligned} & \left\lfloor \frac{|dS(i)| + d}{2} \right\rfloor + 2a + |dF(i)| + |C(i)| + 5a + 2d - 1 + |N_c(i)| \\ &= \left\lfloor \frac{\Delta(G) - |dF(i)| - |C(i)| + d}{2} \right\rfloor + |C(i)| + |dF(i)| + 7a + 2d - 1 + |N_c(i)| \end{aligned}$$

The value of this bound increases when  $|dF(i)|$  or  $|B(i)|$  increases, and thus

$$\begin{aligned} |Forb(i)| &\leq \left\lfloor \frac{\Delta(G) - a - d + d}{2} \right\rfloor + a + d + 7a + 2d - 1 + |N_c(i)| \\ &= \left\lfloor \frac{\Delta(G) - a}{2} \right\rfloor + 8a + 3d - 1 + |N_c(i)| \end{aligned}$$

as required.

Case 3.  $\left\lfloor \frac{\Delta(G)-a}{2} \right\rfloor \geq 2a + d - 1$  and  $|\phi(dS(i))| \leq 4a + d - 1$ .

There are at most  $|\phi(dS(i))| + 6a + 3d - 1 + |N_c(i)|$  forbidden colors for  $i$  by (8). Since we have

$$\begin{aligned} |\phi(dS(i))| + 6a + 3d - 1 + |N_c(i)| &\leq 10a + 4d - 2 + |N_c(i)| \\ &\leq \left\lfloor \frac{\Delta(G) - a}{2} \right\rfloor + 8a + 3d - 1 + |N_c(i)|, \end{aligned}$$

there is at least one available color for  $i$ .

Therefore, in all cases, there are at most  $\left\lfloor \frac{\Delta(G)-a}{2} \right\rfloor + 8a + 3d - 1 + |N_c(i)|$  forbidden colors for  $i$ .

Now, since  $|N(i)| \leq \Delta(G) - 1$ , there are at most  $\left\lfloor \frac{3\Delta(G)-a}{2} \right\rfloor + 8a + 3d - 2$  forbidden colors for  $i$ , and thus at least one available color for  $i$  whenever  $|\Phi| \geq \left\lfloor \frac{3\Delta(G)-a}{2} \right\rfloor + 8a + 3d - 1$ .

Moreover, since, by Lemma 22, we have  $|N_c(i)| \leq 5a + 4d - 1$ , there are at most  $\left\lfloor \frac{\Delta(G)-a}{2} \right\rfloor + 13a + 7d - 2$  forbidden colors for  $i$  and thus the number of forbidden colors is at most  $|\Phi| \geq \left\lfloor \frac{\Delta(G)-a}{2} \right\rfloor + 13a + 7d - 1$ .

This concludes the proof.  $\square$

*Proof of Theorem 4.* When Alice applies the described strategy, every incidence about to be colored has an available color whenever  $|\Phi| \geq \left\lfloor \frac{3\Delta(G)-a}{2} \right\rfloor + 8a + 3d - 1$ , by Lemma 23 if  $i$  is a down-incidence, by Lemma 27 if  $i$  is a medium-incidence, and by Lemma 26 if  $i$  is a top-incidence.  $\square$

*Proof of Theorem 5.* When Alice applies the described strategy, every incidence about to be colored has an available color whenever  $|\Phi| \geq \left\lfloor \frac{3\Delta(G)-a}{2} \right\rfloor + 8a + d - 1$ , by Lemma 23 if  $i$  is a down-incidence, and by Lemma 26 if  $i$  is a top-incidence.

By Lemma 27, if  $i$  is a medium-incidence then  $i$  has an available color whenever  $|\Phi| \geq \left\lfloor \frac{\Delta(G)-a}{2} \right\rfloor + 13a + 7d - 1$ . If  $\Delta(G) \geq 5a + 6d$ , we get  $\left\lfloor \frac{3\Delta(G)-a}{2} \right\rfloor + 8a + d - 1 \geq \left\lfloor \frac{\Delta(G)-a}{2} \right\rfloor + 13a + 7d - 1$  and the result follows.  $\square$

**Acknowledgements.** The authors would like to thank the anonymous reviewers for their valuable comments and suggestions to improve the presentation of this paper. They are also grateful to Mickaël Montassier for his careful reading and commenting on a preliminary version of this paper.

## References

- [1] S. D. Andres. Lightness of digraphs in surfaces and directed game chromatic number. *Discrete Math.*, 309:3564–3579, 2009.
- [2] S.D. Andres. The incidence game chromatic number. *Discrete Appl. Math.*, 157:1980–1987, 2009.

- [3] T. Bartnicki, J. Grytczuk, H. A. Kierstead, and X. Zhu. The map coloring game. *Amer. Math. Monthly*, 114(9):793–803, 2007.
- [4] H.L. Bodlaender. On the complexity of some coloring games. *Int. J. Found. Comput. Sci.*, 2:133–147, 1991.
- [5] O. V. Borodin, A. O. Ivanova, A. V. Kostochka, and N. N. Sheikh. Decompositions of quadrangle-free planar graphs. *Discuss. Math. Graph Theory*, 29:87–99, 2009.
- [6] R.A. Brualdi and J.J.Q. Massey. Incidence and strong edge colorings of graphs. *Discrete Math.*, 122:51–58, 1993.
- [7] C. Charpentier and É. Sopena. Incidence coloring game and arboricity of graphs. *Lect. Notes Comput. Sci.*, 8288:106–114, 2013. Proc. IWOCA 2013.
- [8] T. Dinski and X. Zhu. Game chromatic number of graphs. *Discrete Math.*, 196:109–115, 1999.
- [9] U. Faigle, W. Kern, H.A. Kierstead, and W.T. Trotter. On the game chromatic number of some classes of graphs. *Ars Combin.*, 35:143–158, 1993.
- [10] M. Gardner. Mathematical game. *Scientific American*, 23, 1981.
- [11] D. Gonçalves. Covering planar graphs with forests, one having bounded maximum degree. *J. Combin. Theory, Ser. B*, 99(2):314–322, 2009.
- [12] D. Guan and X. Zhu. The game chromatic number of outerplanar graphs. *J. Graph Theory*, 30:67–70, 1999.
- [13] W. He, X. Hou, K.-W. Lih, J. Shao, W.-F. Wang, and X. Zhu. Edge-partitions of planar graphs and their game coloring numbers. *J. Graph Theory*, 41(4):307–317, 2002.
- [14] M. Hosseini Dolama and E. Sopena. On the maximum average degree and the incidence chromatic number of a graph. *Discrete Math. and Theoret. Comput. Sci.*, 7(1):203–216, 2005.
- [15] M. Hosseini Dolama, E. Sopena, and X. Zhu. Incidence coloring of  $k$ -degenerated graphs. *Discrete Math.*, 283:121–128, 2004.

- [16] H.A. Kierstead. A simple competitive graph coloring algorithm. *J. Combin. Theory Ser. B*, 78(1):57–68, 2000.
- [17] H.A. Kierstead and W.T. Trotter. Planar graph coloring with an uncooperative partner. *J. Graph Theory*, 18:569–584, 1994.
- [18] J.Y. Kim. The incidence game chromatic number of paths and subgraphs of wheels. *Discrete Appl. Math.*, 159:683–694, 2011.
- [19] D. J. Kleitman. Partitioning the edges of a girth 6 planar graph into those of a forest and those of a set of disjoint paths and cycles. (*manuscript*), 2006.
- [20] M. Maydansky. The incidence coloring conjecture for graphs of maximum degree three. *Discrete Math.*, 292:131–141, 2005.
- [21] M. Montassier, P. Ossona de Mendez, A. Raspaud, and X. Zhu. Decomposing a graph into forests. *J. Combin. Theory, Ser. B*, 102(1):38–52, 2012.
- [22] C. St. J. A. Nash-Williams. Decomposition of finite graphs into forests. *J. London Math. Soc.*, 39(1):12, 1964.
- [23] A. Raspaud and J. Wu. Game chromatic number of toroidal grids. *Inform. Process. Lett.*, 109:1183–1186, 1999.
- [24] E. Sopena. [www.labri.fr/perso/sopena/TheIncidenceColoringPage](http://www.labri.fr/perso/sopena/TheIncidenceColoringPage).
- [25] S.D. Wang, D.L. Chen, and S.C. Pang. The incidence coloring number of Halin graphs and outerplanar graphs. *Discrete Math.*, 256:397–405, 2002.
- [26] W.-F. Wang. Edge-partitions of graphs of nonnegative characteristic and their game coloring numbers. *Discrete Math.*, 306:262–270, 2006.
- [27] J. Wu and X. Zhu. Lower bounds for the game colouring number of planar graphs and partial  $k$ -trees. *Discrete Maths*, 308:2637–2642, 2008.
- [28] X. Zhu. The game coloring number of planar graphs. *J. Combin. Theory Ser. B*, 75(2):245–258, 1999.
- [29] X. Zhu. Refined activation strategy for the marking game. *J. Combin. Theory Ser. B*, 98(1):1–18, 2008.