

CELLULAR SOFTWARE DEFINED NETWORKING: A FRAMEWORK

The authors propose a cellular network architecture called CSDN (Cellular SDN), which is based on Software Defined Networking and Network Functions Virtualization. This architecture enables network operators to simplify network management and control. It also enables the creation of new services, in a flexible, open, and programmable manner.

Abbas Bradai, Kamal Singh, Toufik Ahmed, and Tinku Rasheed

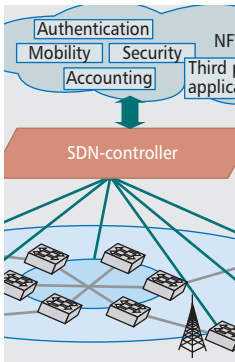

ABSTRACT

Today's mobile customers desire to remain connected anywhere, at any time, and using any device. This phenomenon has encouraged mobile network operators to build complex network architectures by incorporating new features and extensions, which are harder to manage and operate. In this article we propose a novel and simplified architecture for mobile networks. The proposed architecture, which we call CSDN (Cellular SDN), leverages software defined networking (SDN) and network functions virtualization (NFV). SDN abstracts the network and separates the control plane from the data plane; NFV decouples logical network functions from the underlying hardware, for dynamic resource orchestration. Furthermore, we argue that dynamic resource orchestration and optimal control need real-time context data analyses to make intelligent decisions. Thus, in the proposed architecture we exploit the capability of the mobile edge networks to gather information related to the network as well as the users. This information can be used to optimize network utilization and application performance, and to enhance the user experience. In addition, the gathered data can be shared with third party service providers, enabling the realization of innovative services.

INTRODUCTION

Data traffic in mobile networks has recently witnessed an explosive growth with the increasing penetration of smartphones. In addition, users' interests have evolved from voice and short message texts (SMS) to high quality real-time audiovisual content consumption and production. This evolution has pushed 3G networks to their limits, and have motivated network operators to adopt the Long Term Evolution (LTE) network, which is also known as the fourth generation (4G) mobile network. Now the industry is creating the roadmap toward 5G, the fifth generation of mobile network standards.

The LTE architecture proposed by the 3rd Generation Partnership Project (3GPP) [1] is considered an all-IP network that uses an orthogonal frequency division multiplexing (OFDM) air interface. Figure 1 illustrates the

main components of the 3GPP LTE architecture. It is composed of Evolved Universal Terrestrial Radio Access Network (E-UTRAN), containing a set of base stations (e-NodeBs), connected to each other via X2 interfaces. The e-NodeBs connect the user equipment (UE) to the LTE core network, called the evolved packet core (EPC). The EPC is an overlay network that uses IP and Ethernet based packet switched communication.

In an LTE network, mobility management schemes are used to ensure connectivity and to keep the IP addresses of users unchanged, even when users move and change their network. The serving gateway (S-GW) serves as a mobility management anchor and, thus, has to maintain a high number of states related to the mobile users. S-GW is then connected to the packet data network gateway (P-GW), which links the network to the Internet and other data networks. Additionally, the P-GW performs several functions such as monitoring, billing, access control, and enforcement of varied policies. Note that each device in this architecture uses specialized hardware and software to implement varied functionalities, which in turn increase the complexity as well as the cost of the network.

The LTE architecture has been widely adopted by dozens of mobile service providers (MSP) around the world. However, with the emergence of new technologies and services such as cloud computing and content delivery networks (CDNs), the actual structure of the LTE network has become an obstacle to future evolution. The centralized data plane functionalities, such as QoS, access control, and monitoring features, introduce scalability issues at the P-GW. Indeed, in an LTE network, all the traffic should pass through the P-GW, even if the communication is between the UEs of the same cell. This makes the P-GW the hot element of the network [2]. With such a configuration, strategies like caching of the popular content in the mobile network find limited use because all flows have to pass through the P-GW. Additionally, the EPC elements are specialized components with standardized interfaces, where each component achieves a specific task and each interface has a unique definition.

In this context, the introduction of new network functionalities takes a long time from the standardizing process to implementation and market entry. This long process deters network operators from innovating and investing in new network services. Furthermore, the specialized network components, defined exclusively for EPC, suffer from inflexibility and lack of openness. Each EPC element is controlled through standardized interfaces, and cannot be controlled by open interfaces or through application programming interfaces (APIs). In case the network operator plans to introduce new network services or needs to adopt new functionalities, the existing network components become useless, or of little use, to implement the envisaged functionalities.

COMMUNICATIONS STANDARDS

Abbas Bradai is with CNRS Grenoble Informatics Laboratory.

Kamal Singh is with Laboratoire Hubert Curien/Université de Saint-Etienne.

Toufik Ahmed is with University of Bordeaux.

Tinku Rasheed is with Create-Net Research Center.

CELLULAR SOFTWARE DEFINED NETWORK: OVERVIEW

In order to overcome the challenges introduced in the previous section, we propose a cellular network architecture called CSDN (Cellular SDN), which is based on Software Defined Networking (SDN) [3] and Network Functions Virtualization (NFV) [4]. This architecture enables network operators to simplify network management and control. It also enables the creation of new services, in a flexible, open, and programmable manner.

Figure 2 provides an overview of the proposed architecture. CSDN leverages the benefits of SDN and NFV for dynamic resource management and intelligent service orchestration. The NFV platform is a cloud-based radio access network (C-RAN) [5] which allows the orchestration of resources using virtualization techniques. It uses different virtual machines running multitudes of applications over the cloud infrastructure of an MSP. An application within this framework, for instance MME (mobility management element) can not only run on virtual machines, but can also adapt its capabilities in an elastic way depending on the network load. This makes it very easy and flexible for network dimensioning and resource allocation.

Additionally, the proposed architecture leverages the SDN concepts for the orchestration of intelligent services. Here, by intelligent services we refer to the services that allow an MSP to implement subscriber policy, profile-aware service provisioning at the level of individual flows, etc. However, to realize these intelligent services, the MSP needs to take decisions based on data analytics. This requires a data component similar to a user data repository (UDR) [5]. We extend this data component to create the context data repository (CDR), which includes additional information such as network data, user profiles, and usage data.

In our CSDN architecture, mobile operators gather data related to the network as well as related to users. Network data includes traffic load, bandwidth availability, wireless channel information, and network health information such as network points suffering from congestion or other problems. This data is combined with subscriber data related to usage, quality of experience (QoE), as well as subscriber profiles including user behavior and preferences. Combining network data with user data allows the MSP to connect network-centric data with the user-centric data, allowing for intelligent resource allocation and provisioning, while considering the network conditions in real time. With this process, the MSP can optimize the user experience, reducing user churn, while minimizing network resource utilization at the same time. It also enables easier network evolution for better performance to support new technology. In the following, we provide a brief overview of SDN and NFV concepts, and then we illustrate the features and benefits of our CSDN architecture.

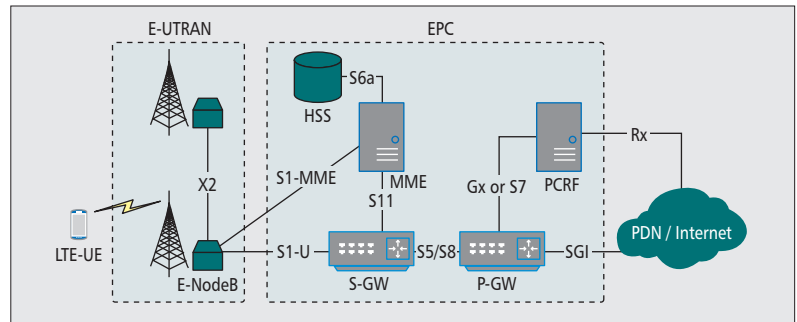

Figure 1. LTE network architecture.

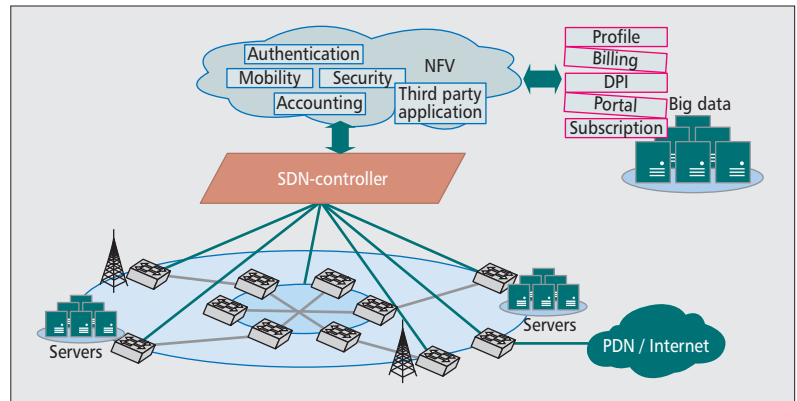

Figure 2. CSDN overview.

SDN AND NFV FOR INTELLIGENT SERVICES ORCHESTRATION AND DYNAMIC RESOURCES MANAGEMENT

SDN (software defined networking) is clearly climbing the technological hype cycle every day as a novel approach that separates the control plane from the data plane (Fig. 3a). The control plane is logically centralized and controls the data forwarding elements of the network using an open interface. SDN originated from the need to solve the problems in managing fast-evolving Telco networks that require cumbersome configuration measures of several network equipments, which is a complex task. The key to solving such problems is through the automation of the control through application programming interfaces, and enabling virtualization of network functions by hiding the detailed configuration process from network control. SDN provides a flexible and centralized way to configure network equipment where network applications can be built on top of the SDN control plane for intelligent management of the network. These management applications can take optimal decisions, which in turn can be automatically compiled into network configuration rules. The latter are simple rules based on packet headers that are handled by the SDN controller to communicate to the SDN-enabled switches that implement them. This centralized approach significantly reduces the effort required to configure a network, and at the same time reduces the occurrence of problems such as downtime due to misconfigurations or failures.

Together, SDN and NFV can enable MSPs to make their network services dynamic, which will allow them to optimize their network resources, increase the agility of network, implement novel services, and hasten the process from service design to service production.

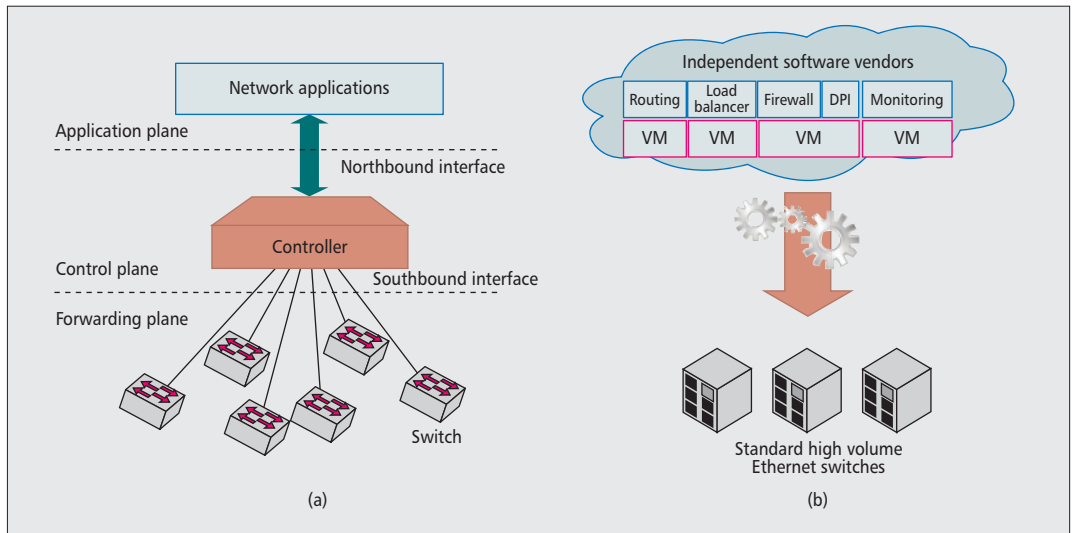

Figure 3. Architecture of SDN and NFV: a) SDN architecture; b) network function virtualization.

While SDN allows the network layers to be programmable by separating the data plane from the control plane, NFV technology provides the capability of flexible networking service placement. The concept of NFV, as defined by the European Telecommunications Standard Institute (ETSI) committee [4], is to decouple the network function from the hardware, as shown in Fig. 3b. The decoupled network functions are implemented using software. NFV combines virtualization and cloud computing techniques and applies them to telecommunication networks. It virtualizes the networking functions referred to as virtualized network functions (VNF). These network functions are then interconnected or chained to create networking services. The VNFs are deployed over one or more virtual machines and use generic hardware, such as off-the-shelf servers, instead of vendor-specific hardware. The use of generic hardware leads to significant cost reductions. Additionally, NFV can benefit from the centralized control and network layer programmability offered by SDN. Together, SDN and NFV can enable MSPs to make their network services dynamic, which will allow them to optimize their network resources, increase the agility of network, implement novel services, and hasten the process from service design to service production. Further, this approach enables easy upgrading and network capacity expansion to support resource sharing between multiple-tenants and support for multi-cell collaborative signal processing.

FRAMEWORK FOR SOFTWARE DEFINED CELLULAR NETWORK ARCHITECTURE

While several SDN based architectures and solutions have been proposed [3], most of these works concern wired networks. Adapting SDN technology to the context of mobile networks is challenging due to mobile network specific issues such as handling user mobility, management of the radio resources, and addressing resource scarcity in the wireless environment. Indeed,

scalability problems related to the mobile SDN need to be addressed such as the update of many fine-grained rules related to the traffic management of a high number of mobile users. The network should be able to keep multitudes of states required for mobility management, monitor flows, detect if the user traffic exceeds its pre-assigned quota, perform billing, assure QoS, congestion control, and optimize resource utilization. In the literature there are few works addressing SDN applied to wireless and mobile networks [7, 8]. While the authors in [7] propose a high level SDN-based architecture for future mobile networks, it lacks details and requirements for the real deployment of such an architecture. While the authors in [8] focus mainly on radio virtualization to provide effective resource virtualization, the approach can compromise overall system performance.

Figure 4 provides a detailed overview of the proposed cellular SDN architecture (CSDN). CSDN follows the SDN layering architecture and comprises the following layers: forwarding layer, control layer, and the network application layer. We expand this model by considering an additional functional layer called the knowledge layer that allows the MSP to gain insights into the intelligent vision of its network and users environment. In the following, we detail the most important aspect of the proposed architecture with a focus on mobile network-specific components.

LTE VIRTUALIZED FUNCTIONS

Figure 5 illustrates the mobile network application layer of CSDN. The majority of the LTE EPC's functional elements are implemented in a centralized cloud-based infrastructure at the application level of CSDN. These virtualized network functionalities interact at the management and control level with the CSDN switches via the controller. In addition to these basic network functionalities, our architecture allows new applications or virtual functions to be implemented and instantiated, such as video adaptation and optimization, which can be easily

introduced using the northbound interface of the controller.

This flexibility makes it possible to build network applications that are not only 3GPP compliant, but also implement innovative schemes from third party providers, such as location based services, Internet of Things (IoT) applications, and optimized content distribution and content caching. In Fig. 5 we show the network applications complying with the 3GPP standard. The V_e-NodeB with the CSDN switch corresponds to the e-NodeB functionalities, the same for V_S-GW, V_P-GW, V_MME, and V_PCRF that correspond with their switches to the S-GW, P-GW, MME, and PCRF respectively. Due to the lack of space, we provide details for the functionalities of V_e-NodeB and V_MME below.

Radio Resource Management (V_e-NodeB): Radio resource management (RRM) is a big part of a mobile network and several RRM functionalities are present in LTE e-NodeBs. The base stations use distributed protocols for the allocation of shared radio resources and participate in the management of sessions, handovers, interference, admission control, etc. However, distributed protocols are sub-optimal as compared to centralized optimization schemes having a global vision. Thus, following SDN philosophy, we decouple the control plane from the radio equipment. The radio equipment is controlled from a centralized control plane, and this centralization makes it easier to perform radio resource allocation as well as backhauling. For example the controller can perform load balancing between several base stations by moving users from a congested base station to another base station, cooperative MIMO techniques can be employed to enhance the signal quality, and lightly loaded base stations can be put in sleep mode to reduce energy consumption.

Mobility Management (V_MME): Mobility management is another important issue in cellular networks. Mobility management can be implemented in CSDN conforming to the 3GPP standard as an application on top of the CSDN controller. This becomes possible thanks to the northbound interface. In Fig. 5a, we show the V_MME as a part of the virtual EPC (V_EPC) which respects the 3GPP standard. While the V_e-NodeB manages the radio resources and ensures physical mobility, i.e., the handover, the V_MME ensures the MME functionalities. The difference between CSDN and normal mobile networks is that the signaling and tunneling functionality of mobile networks, such as GTP tunneling, is compiled into CSDN packet flow rules. The controller sends these rules to the CSDN switches. Thus, the networking policies and functionalities related to QoS, metering, tunneling, and routing are compiled into packet flow rules, which in turn are used to configure the CSDN switches.

DESIGN CONSIDERATION AT THE FORWARDING PLANE

Openflow is an open SDN standard that allows communication between the control plane and the network switches [9]. The switches defined by Openflow already provide functionalities such as

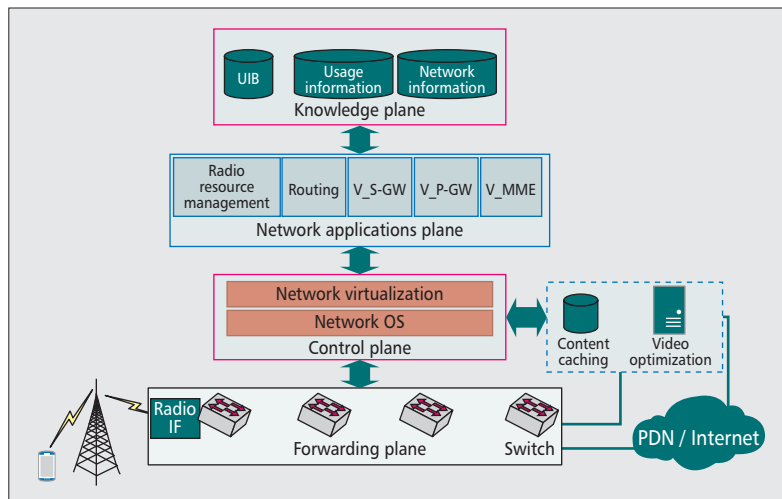

Figure 4. Cellular software defined network.

network traffic measurement and management to network operators, allowing measurement of network traffic, subscriber's usage statistics, perform billing, assess the QoS and then flexibly change the path of a user's flow to optimize as well as enforce QoS network policies. However, applying current Openflow based SDN architecture remains insufficient for mobile networks. This is due to the peculiarities of mobile networks that suffer from scalability issues, essentially due to an increasing number of users, their mobility, the fine grain access control, QoS policies, and the nature of being a wide area network, and the scarcity of the radio resources. Centralized management of mobile networks addressing these issues makes the SDN controller a bottleneck. In addition, the frequent controller solicitation introduces additional delay, which can impact QoS. For these reasons, the local features in a CSDN network switch should be increased to discharge some functionalities from the controller. In particular, the switch should be able to execute a local program for performing simple tasks under the supervision of the controller, such as notifying the controller if the traffic exceeds a certain threshold, tagging some packets to be redirected to a transcoder, etc. There needs to be more in-depth investigation of this balance of delegating controller functionalities to CSDN switches and at the same time keeping these switches as simple as possible.

In addition, new switch capabilities will be beneficial to software-defined cellular networks. Today, TCP/UDP port numbers are no longer a reliable way to identify applications. Instead, support for deep packet inspection (DPI) would enable finer-grain classification of the applications, such as Web, peer-to-peer, video, and VoIP traffic. This is important to divide traffic into separate traffic classes for differential packet scheduling and routing policies, as commonly done in today's cellular networks. DPI will also help intrusion detection and prevention systems that analyze packet contents to identify malicious traffic. The DPI functionality could be enabled only on some switches, and applied only for some packets for better scalability and performance of the switches. In addition to DPI,

One of the main advantages of the SDN paradigm is the fact that it provides an API's interface to easily develop new applications and services. The controller receives policies from the applications and provides them a virtual view of the network.

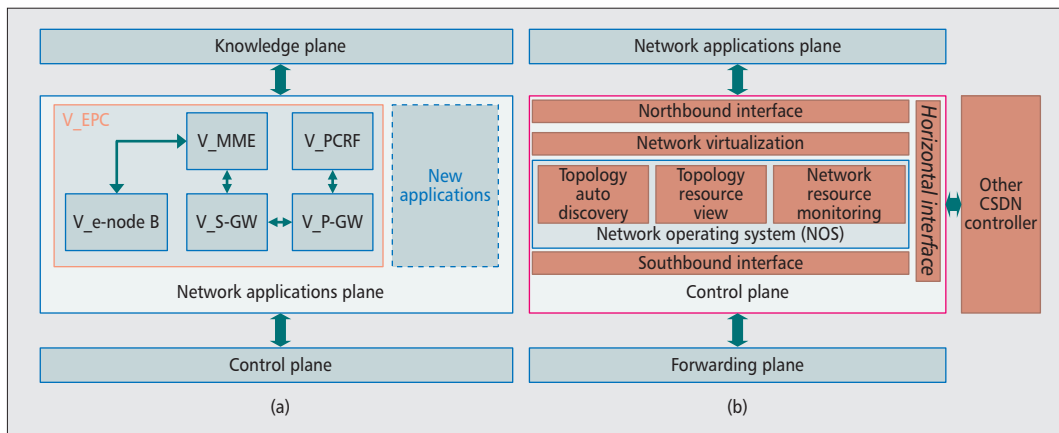

Figure 5. CSDN architecture details: a) network applications plane; and b) control plane.

some CSDN switches should perform other tasks such as header compression, mainly for small payload packets, such as VoIP packets. These switches could be deployed in low bandwidth regions of the network.

DESIGN CONSIDERATION AT THE CONTROL PLANE

The CSDN controller (Fig. 5b) consists of a network operating system (NOS), a network virtualization block, and three communication interfaces. The core component of the controller is the NOS, whose main feature is to abstract the distributed state of the network and provide a global view of the network. The NOS is composed of three main building blocks: network resource monitoring, topology auto-discovery, and topology resource view. The second level of abstraction is performed by the *network virtualization* building block, which provides an abstract view of the network. This view in turn is exploited by the applications.

The three communication interfaces are the northbound, the southbound, and the horizontal interfaces (east-west). The *southbound interface* controls the CSDN switches via simple forwarding rules. It receives the network measurements and in some cases it also receives packets from the switches. In the case where a packet does not match with any rule in the forwarding table, the packet is sent to the controller. The controller analyses the packet with respect to the policies of the application layer and a new forwarding rule is pushed to the switch. The *horizontal interface* allows a controller to communicate with other CSDN controllers and to support third party interactions. Indeed, as shown in [3], a single controller for a large network introduces scalability issues. In CSDN, we propose a controller for each public land mobile network (PLMN). For this purpose coordination is needed between the different controllers in order to get a global view of the network and to coordinate actions in case of inter-PLMN communications. Finally, the *northbound interface* allows communication with the network applications. One of the main advantages of the SDN paradigm is the fact that it provides an API's interface to easily develop new applications and services. The controller receives policies from the applications and provides them a virtual view of the network.

CONTEXT DATA FOR NETWORK OPTIMIZATION AND INNOVATIVE APPLICATIONS

Mobile operators gather information related to the mobile access network such as ongoing traffic, bandwidth availability, points of congestion, etc. The big data analysis techniques using network information data combined with the subscriber information data related to their profile and behavior can provide valuable insights to the network operator for network optimization and innovative personalized applications [10, 11]. Based on the network conditions, channel information, user profile, and device properties among many other data that could be considered, the MSP can leverage connection prioritization, audio/video transcoding, and quality selection to enable multi-screen customization and adaptability as an innovative service.

The main advantage of using the gathered data in CSDN is that the central decision making entity can gather a global view of the network. Boosting this central entity with big data tools allows it to have a global and insightful view of subscriber behavior, situational awareness, and the service evolution. Furthermore, MSPs are many steps ahead, as compared to digital service providers, in terms of the breadth and depth of data collection as well as data quality and reliability. The MSPs' role as the connection provider grants them access to individual-level information continuously and accurately, given that they have 'around-the-clock' connection to each and every subscriber, regardless of their location. The MSPs can share their data with third-party partners, allowing them to rapidly deploy innovative applications and services for mobile subscribers, enterprises, and other vertical segments. For example, this information enables enterprises to better understand local markets, such as local commercial areas, popular products and companies, and user behavior in order to serve their customers via just-in-time location-based services based on the gathered information.

Proximity, context, agility, and speed can be translated into value and can be exploited by the MSPs, service and content providers, over the top (OTT) players, and independent software

vendors (ISVs), enabling them to play complementary and profitable roles within their respective business models, and allowing them to monetize the mobile broadband experience and create an energized ecosystem. Based on innovation and business value, this value chain will allow all players to benefit from greater cooperation. To this end, a standardized, open architecture should be designed toward efficient and agile integration of such applications across multi-vendor mobile network platforms. In the following sections we present the different components and interfaces of the context data plane in our CSDN architecture, and then we explore the main obstacles and challenges to overcome.

Before we go through the details, it is essential to identify the different data gathered by mobile operators. The data gathered by mobile operators can be categorized into the following three classes of information, grouped into what we call the context data repository (CDR):

User Information Base: Mobile operators have accurate subscriber information. They have the true identity of the subscriber as well as some basic information about them such as the address for user identification and addressing, which corresponds to the international mobile subscriber identity (IMSI) and the mobile subscriber ISDN number (MSISDN) or telephone number. All this information is stored in the User Information Base (UIB). The latter also contains the user profile information, which concerns the service subscription status and user-subscribed QoS information such as maximum allowed bit rate or allowed traffic class. In addition, UIB can give an idea about the subscriber's economic status via device type, subscription type, and social activity via call minutes, frequency dial number, and exchanged messages.

Network Information Base: Mobile operators have the ability to gather fine grain information about any user, including real time information about the user's location as well as their activity and navigation information, in addition to the device information and connection characteristics. This information can be gathered thanks to the signaling through the base station, femto-cells, and switches. The gathered information, once analyzed, can be converted into high level patterns of users' activity, consumption, and lifestyle, whereas wireless channel information and scheduling information (QoS, channel quality indicator, load) can be used to enhance network performance.

Usage Information: Using DPI and other related technologies, the network operators are also able to extract information about the subscriber's consumed content and applications used to learn about their browsing activities, preferences, and centers of interest. Network operators can also have access to the subscriber's economic information through their online shopping and e-banking activities. This information allows the operators to decipher subscribers' social and economic ecosystems, including their brand choices.

In addition to having real-time information, MSPs also have historical data that is captured continuously over long periods of time. This is possible thanks to their subscription manage-

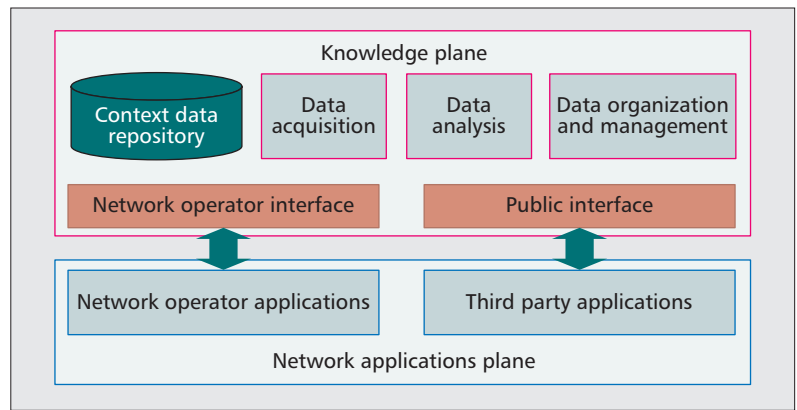

Figure 6. Knowledge plane.

ment systems, billing and charging management systems, portals, and customer service systems, which are configured to record this information over the lifetime of each subscription. MSPs can use this historical data to conduct trends analysis and understand long term usage patterns.

KNOWLEDGE PLANE IN CSDN FRAMEWORK

Current SDN forwarding devices match basic packet headers with the forwarding table rules to perform actions such as routing, packet header modification, packet dropping, etc. In order to support more advanced network applications, the CSDN maintains and updates the user, network, and usage data. The NOS can then “compile” these policies expressed in terms of user information into forwarding rules executed by the switches. In Fig. 6 we provide an overview of the proposed knowledge plane in our CSDN framework. The knowledge plane is composed of three functional blocks and two interfaces. The data acquisition block allows gathering of information either from the network, through a network application running in the application layer of CSDN, or through other information sources such as the network operator portal. After the acquisition of data, the next step is to analyze the data to provide valuable insights to the network operator and enable a comprehensive analysis of this data in terms of subscribers' network conditions, navigation patterns, lifestyles, events, and the movement of people. This is realized by the data analysis block. Finally, the data organization and management block enables organizing the raw data to facilitate its exploitation. The knowledge plane uses a bidirectional communication interface to communicate with the MSP applications that have privileged access to all the data. However, third party applications have limited access to the data, through the public interface, in order to preserve subscribers' privacy and deny public access to sensitive data.

PRACTICAL CONSIDERATIONS FOR CONTEXT DATA IN CSDN

Once we have defined the information that can be gathered by the MSPs, we need to identify the challenges and practical limits of contextual data for mobile SDN. In the following paragraphs we explore the main issues, the obstacles and the challenges to overcome in order to move toward big-data centric cellular SDN networks.

The ONF is a key organization that is standardizing SDN technologies. It produced the OpenFlow standard that is used in the current article. The OpenFlow standard specifies the OpenFlow switch and the OpenFlow protocol that is used by the SDN controller to communicate with the OpenFlow switches.

There are a number of practical considerations to be addressed before moving toward a dynamic, flexible, and centralized mobile network infrastructure that exploits multiple data sources [12].

Centralized vs. Distributed Collection of Data and Data Sampling Granularity: In order to collect data about the subscriber and their environment, the mobile operator exploits traditional methods such as the mobile operator offices and call centers. However, the subscribers are more and more reluctant to provide information about themselves. Thus, network operators try to gather user information within their network (using DPI for example), from the subscriber's devices or from service portals. However, using techniques such as DPI faces many regulatory and technical challenges. Governments are more and more restrictive about their citizens' privacy. Using DPI to collect information about subscribers could be regulated. For example, the type of information, their anonymization, and their storage are strictly regulated. In addition, gathering huge and real time information distributed over different network devices is technically challenging and can reduce network performance. The challenge is then to design scalable and failure-resilient data gathering approaches. Once gathered, the placement of the data storage is an important challenge, mainly to identify if a centralized or distributed solution is the most appropriate choice.

In addition, most data analysis tools use sampling in their process. In the case of real-time network adaptation, fine grain sampling is required. This will impact network performance and will create additional complexity. Furthermore, in the case of non-real-time network sampling, there needs to be the right balance in choosing the frequency of sampling in order to avoid the data becoming obsolete.

Data Processing: Once the network operator collects the data, the next challenge is to process this huge amount of data. Such data is multi-source, heterogeneous, real-time, voluminous, and continuous, as well as static, ever-expanding, and having spatio-temporal dimensions. Streaming data analysis and knowledge extraction techniques are required to process this data coming from heterogeneous sources in order to convert it into actionable knowledge. The data processing needs to detect correlations in the data and discover patterns or abnormalities in dynamically evolving situations. Regarding the real-time aspects, we argue that the processing method depends on the real-time needs of the target application. Thus, the collected data should be classified into real-time data and non-real-time data. For instance, data related to user position should be processed in near real time, while data related to user preferences could be processed in a non-real-time manner.

Advanced Decision Making and Data Antiquity: Historical data can be combined with advanced models for the purpose of forecasting and advanced decision making. The objective is to forecast problems in the network and take preventive measures. The open issues are to design these forecasting models and advanced decision making tools. Note that network opera-

tors store historical information about the user in order to build a global image about their environment, behavior, and preferences in order to forecast requirements and enhance their experience. The amount of data and the time for which the respective data needs to be stored depends on different parameters, including the respect of the privacy jurisdiction, the utility degree of the data, and performance impact of the data quantity on the processing process.

User Privacy and Data Security Issues: The security of the gathered data is another issue. Mechanisms should be implemented to guarantee a satisfactory level of data safety. Therefore, data anonymization techniques should be considered to respect user privacy.

RELEVANCE TO STANDARDIZATION BODIES AND FORA

The Open Network Foundation (ONF)¹ is a key organization that is standardizing SDN technologies. It produced the OpenFlow standard that is used in the current article. The OpenFlow standard specifies the OpenFlow switch and the OpenFlow protocol that is used by the SDN controller to communicate with the OpenFlow switches. ONF has several working groups, and one of the groups related to mobile networks is the Wireless and Mobile Working Group (WMWG). This working group collects use cases and determines the architectural and protocol requirements for extending ONF technologies, such as the OpenFlow standard, for mobile and wireless networks. It has already drafted many use cases related to SDN utilization for network management and control, mobility management, flexible and scalable packet core, and virtualization for mobile networks.

The European Telecommunications Standards Institute (ETSI)² has an industry standardization group dedicated to Network Function Virtualization (NFV)³ technology. At the completion of its Phase I, this working group published several NFV specifications in October 2013. Many of these specifications are related to defining the requirements and architecture for the virtualization of network functions, management and orchestration of virtual network appliances, and requirements and gap analysis for future technical specifications. In addition, the ETSI NFV working group provides a framework called proof of concept (PoC) for open demonstrations of NFV concepts. The PoC framework helps in building awareness and confidence in NFV technologies. It also provides feedback about challenges related to the implementations of NFV concepts and their interoperability. The ETSI NFV working group is now entering Phase 2 and its objectives are to ensure end-to-end inter-working of equipment and services. One of the objectives of ETSI NFV Phase 2 is also to clarify how NFV intersects with SDN technology and standards, which is one of the topics of the current article.

The Internet Engineering Task Force (IETF)⁴ has several years of working experience on concepts related to SDN. One such example is the existing working group called Forwarding and Control Element Separation (FORCES). Some recent working groups have also emerged, such as

¹ <https://www.opennetworking.org/>

² <http://www.etsi.org>

³ <http://www.etsi.org/technologies-clusters/technologies/nfv>

⁴ <https://www.ietf.org>

Interface to the Routing System (I2RS), whose objective is to define the interfaces for the control of the routers and routing protocols. Moreover, more new working groups are being initiated such as Virtual Network Function Pools (VNF pools) to provide support mechanisms for the reliability of a group of virtual network functions, and the working group called Abstraction and Control of Transport Networks (ACTN) that targets network partitioning and resource slicing for clients, and also network automation and orchestration. Additionally, the Internet Research Task Force (IRTF) has a working group called the Software-Defined Networking Research Group (SDNRG) which aims at helping the other standardization organizations by investigating the interesting open research issues related to SDN.

This article targets the orchestration of services and network resources using SDN and NFV technologies, which are the topics of ongoing standardization activities as described above. This article also treats the intersection of SDN and NFV technologies, which is the objective of Phase 2 of the ETSI NFV group. Moreover, this article proposes a new architecture for mobile networks with the addition of a knowledge plane, which will help mobile operators gain more granular and user-aware control as well as orchestration of services and network resources.

CONCLUSIONS

We introduced CSDN, an architecture for future mobile networks that adopts the separation of the data plane from the control plane for intelligent service orchestration, and virtualization of network functions for centralized dynamic resource management. We discussed the design considerations of the proposed framework at different architectural levels, and we outlined the amendments that need to be introduced to current SDN approaches in order to adopt it in future cellular networks. Furthermore, CSDN takes advantage of the data generated at the last mile by MSPs to compile comprehensive information about users and their network conditions in order to optimize network utilization and to enhance the user experience by providing user-adapted, context-related, and personalized services. Such information can transform the network operator into a big data operator with the capability to share their data with third party service providers for innovative applications. In this context, we investigated the different challenges and obstacles to overcome before having a standardized and open architecture for extraction, management, and exploitation of contextual data in mobile networks. We expect that CSDN with big data analyses can catalyze the innovation in future cellular networks while reducing the cost and time-to-market for new adapted and personalized services.

REFERENCES

- [1] 3GPP TS 36.300 (v10.8.0), "Evolved Universal Terrestrial Radio Access (E-UTRA) and Evolved Universal Terrestrial Radio Access Network (E-UTRAN); Overall Description; Stage 2 (Release 10)," July 2012.
- [2] J. H. Lee *et al.*, "Distributed IP Mobility Management from the Perspective of the IETF: Motivations, Requirements, Approaches, Comparison, and Challenges," *IEEE Wireless Commun. Mag.*, vol. 20, no. 5, Oct. 2013, pp. 159–68.
- [3] A. Reaz and R. Boutaba, "Design Considerations for Managing Wide Area Software Defined Networks," *IEEE Commun. Mag.*, vol. 52, no. 7, 2014, pp. 116–23.
- [4] ETSI NFV White Paper, available: http://portal.etsi.org/nfv/nfv_white_paper.pdf.
- [5] T. Taleb, "Towards Carrier Cloud: Potential, Challenges, & Solutions," *IEEE Wireless Commun. Mag.*, vol. 21, no. 3, June 2014, pp. 80–91.
- [6] User Data Convergence (UDC), 3GPP Technical Specification (TS 29.335), available: <http://www.3gpp.org/DynaReport/29335.htm>.
- [7] C. J. Bernardos *et al.*, "An Architecture for Software Defined Wireless Networking," *IEEE Wireless Commun.*, 2014, vol. 21, no. 3, pp. 52–61.
- [8] L. E. Li, Z. M. Mao, and J. Rexford, "CellSDN: Software-Defined Cellular Networks," Technical Report, Princeton University, 2012.
- [9] N. McKeown *et al.*, "OpenFlow: Enabling Innovation in Campus Networks," *ACM SIGCOMM Comp. Commun. Rev.*, 38.2, 2008, pp. 69–74.
- [10] T. Taleb and A. Ksentini, "Follow Me Cloud: Interworking Federated Clouds & Distributed Mobile Networks," *IEEE Network*, vol. 27, no. 5, Sept./Oct. 2013, pp. 12–19.
- [11] P. Makris, D. Skoutas, and C. Skianis, "A Survey on Context-Aware Mobile and Wireless Networking: On Networking and Computing Environments' Integration," *IEEE Commun. Surveys & Tutorials*, no.99, pp. 1–25.
- [12] M. Bushong, 2013, Oct., SDN, Big Data and the Self-Optimizing Network, available: <http://www.infoworld.com/article/2612727/sdn/sdn--big-data--and-the-self-optimizing-network.html>.

BIOGRAPHY

ABBAS BRADAI (bradai@imag.fr) received his M.S in computer science from the National Institute of Computer Science (ESI ex-INI), Algiers, Algeria, and from The University of Rennes1, France in 2009, and his Ph.D. at the LaBRI/University of Bordeaux-1, France, in 2012. He is an assistant professor at the University of Grenoble and a research fellow at LIG lab, Grenoble. His main research interests are multimedia communications over wired and wireless networks, cognitive radio, software defined networking, and virtualization. He is/was involved in many French and European projects (FP7, H2020) such as ENVISION, VITAL, Data-Tweet.

KAMAL D. SINGH (kamal.singh@univ-st-etienne.fr) obtained his Ph.D. degree in computer science from the University Rennes 1, France in 2007. He then worked as a post doc in the Dionysos group at INRIA, where he co-developed many components of quality of experience estimation tools, and worked mainly on the analysis of video-based applications. He is currently an associate professor at the University of Saint Etienne/Telecom Saint Etienne, France. His research interests include quality of experience, video streaming, software defined networking, big data and semantic web.

TOUFIK AHMED (tad@labri.fr) is currently a professor at ENSEIRB-MATMECA School of Engineers in the Institut Polytechnique de Bordeaux (IPB), and is performing research activities at the CNRS-LaBRI Lab-UMR 5800 at the University Bordeaux 1. His main research activities concern quality of service (QoS) management and provisioning for multimedia wired and wireless networks, media streaming over P2P network, cross-layer optimization, and end-to-end QoS signaling protocols. He has also worked on a number of national and international projects. He is serving as TPC member for international conferences including IEEE ICC, IEEE GlobeCom.

TINKU RASHEED (tinku.rasheed@create-net.org) is a senior research staff member at Create-Net. Since May 2013, he has been heading the Future Networks R&D Area [FuN] within Create-Net. Before joining Create-Net in December 2006, he was a research engineer with Orange Labs R&D from May 2003 until November, 2006. He received his Ph.D. degree from the Computer Science Department at the University of Paris-Sud XI, in 2007. He completed his M.S. degree in 2003 from Aston University, U.K. specializing in telecommunication engineering, and his bachelor degree in 2002 in electronics engineering from the University of Kerala, India. He has extensive industrial and academic research experience in the areas of mobile wireless communication and data technologies, and end-to-end network architectures and services. He has several granted patents on distributed protocols for wireless networking, and has published his research in major journals and conferences.

CSDN takes advantage of the data generated at the last mile by MSPs to compile comprehensive information about users and their network conditions in order to optimize network utilization and to enhance the user experience by providing user-adapted, context-related, and personalized services.