

Chapter 1

Introduction

1.1 What is a translation surface?

1.1.1 Three examples

A translation surface is a flat object constructed by gluing polygons along parallel sides of the same size using translations. Before introducing formal definitions let us discuss three illustrative examples of these:

A flat torus. Consider the unit square in \mathbb{C} given by $0 \leq \operatorname{Re}(z), \operatorname{Im}(z) \leq 1$ and identify parallel sides using translations. That is, if $z = x + iy$, we identify each real point x in the lower side of the square with $x + i$ and each purely imaginary point iy in the left side of the square with $1 + iy$. The result is a surface M homeomorphic to a torus and which has the special property that *every* point $z \in M$ has a small neighbourhood isometric to a neighbourhood of the origin in \mathbb{C} .

A genus 2 surface. Consider three copies of the unit square, glue them and label their sides as depicted in Figure 1.1. If we identify edges with the same labels using translations, the result is a genus 2 surface¹. In this surface all points *except one* have a small neighbourhood isometric to a neighbourhood of the origin in \mathbb{C} . The “problematic” point, which we denote by p_0 , appears because all vertices are merged by the identifications into a single point. In the lower part of Figure 1.1 we illustrate a small neighbourhood U_{p_0} of p_0 . Remark that U_{p_0} is not isometric to a neighbourhood of the origin in \mathbb{C} . It is however isometric to the space obtained by gluing cyclically 3 copies of a neighbourhood of the origin in \mathbb{C} , which is an example of *ramified covering* of degree 3. For this reason, p_0 is called a *conical point* of total angle 6π .

Both the flat torus and the genus 2 surface are examples of *finite type* translation surfaces.

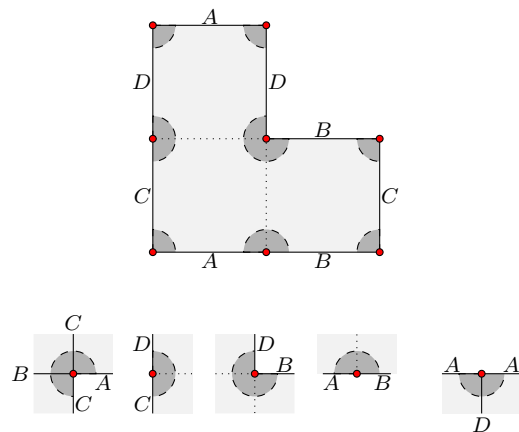

Figure 1.1: A genus 2 translation surface and a neighbourhood of the conical point.

¹This can be shown easily by calculating the Euler characteristic the surface: $2 - 2g = V - E + F$ where g is the genus, $V = 1$ is the number of vertices, $E = 6$ is the number of edges and $F = 3$ the number of faces.

The infinite staircase. Consider a countable family of squares and identify their parallel sides as depicted in figure 1.2, where pairs of opposite (parallel) sides are identified using translations. Every point which is not a vertex has a neighbourhood that is isometric to a neighbourhood of the origin in \mathbb{C} . On the other hand, it is relatively easy to see that after identifications all vertices involved merge into four points. In figure 1.2 below we depict with a dashed line the boundary of a small neighbourhood of one on these four points, which we denote by U_{z_0} and z_0 respectively. Remark that U_{z_0} can be constructed by gluing cyclically *infinitely* many copies of a neighbourhood of the origin in \mathbb{C} . However, z_0 is worse than the problematic point from the preceding example because z_0 *does not have compact neighbourhoods*. In other words, because of “very problematic” points like z_0 the topological space that we have constructed *is not locally compact*, and hence not a surface. For this reason we remove all the vertices of the squares involved in the construction. The result is an *infinite type* translation surface called the infinite staircase. The nomenclature in this case is justified because, as we will see later, this surface has infinite genus.

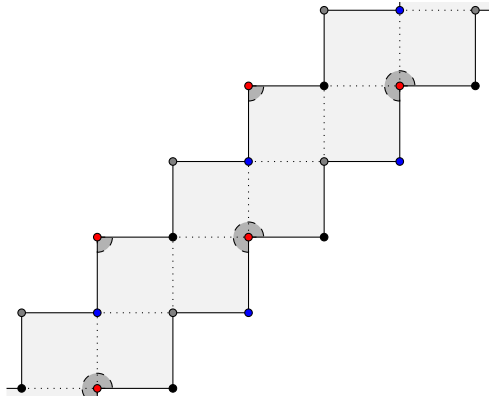

Figure 1.2: The infinite staircase. Opposite sides are identified. There are four infinite degree vertices in the surface.

before. This is the definition that will be used to present most examples in Section 1.2. First let us define an *Euclidean polygon* as a simply connected and bounded closed set in the Euclidean plane whose boundary is a curve formed by finitely many segments. Let \mathcal{P} be an at most countable family of Euclidean polygons and $E(\mathcal{P})$ be the set of all the edges in \mathcal{P} . For each edge $e \in E(\mathcal{P})$ we consider n_e the (unit) vector normal to e which points toward the interior of the polygon having e as a side. Suppose that there exists $f : E(\mathcal{P}) \rightarrow E(\mathcal{P})$ a pairing (that is an involution without fixed point) such that for every $e \in E(\mathcal{P})$ the edges e and $e' = f(e)$ differ by a translation τ_e and $n_{e'} = -n_e$.

Let $\bigsqcup_{P \in \mathcal{P}} P$ be the disjoint union of the polygons in \mathcal{P} . For every $e \in E(\mathcal{P})$ seen as a subset of $\bigsqcup_{P \in \mathcal{P}} P$, we identify the points in e with the points in $f(e)$ using τ_e . Note that each point in the interior of an edge e is identified with exactly one point in $f(e)$. This operation produces a topological space where the quotient map $\pi : \bigsqcup_{P \in \mathcal{P}} P \rightarrow (\bigsqcup_{P \in \mathcal{P}} P) / \sim$ is 1-to-1 in the interior of each polygon, 2-to-1 on the edges and n -to-1 on vertices, where n can be a natural number or ∞ that depends on the vertex. For example, in the L shaped surface of Figure 1.1 we have $n = 12$ while the infinite staircase in Figure 1.2 has $n = \infty$. We say that a vertex $v \in P \in \mathcal{P}$ is of *finite degree* if $\pi^{-1}(\pi(v))$ is finite and of *infinite degree* otherwise. This notion takes care of vertices which merge into “very problematic” points like the ones we created when constructing the infinite staircase (see Lemma 1.1.3).

Definition 1.1.1 (Constructive). Let \mathcal{P} be an at most countable set of Euclidean polygons and $f : E(\mathcal{P}) \rightarrow E(\mathcal{P})$ a pairing as above. Let M be $\bigsqcup_{P \in \mathcal{P}} P / \sim$ deprived of all vertices of infinite degree. If M is connected we call it *the translation surface obtained from the family of polygons \mathcal{P}* .

These three examples will appear all along this text. Flat tori have been studied since the 19th and early 20th centuries, by L. Kronecker and H. Weyl, among others. The surface of genus 2 in the second example is a particular case of a compact translation surface. These kind of translation surfaces have been studied since the 1970’s and their theory is well-developed. This book assumes some basic knowledge of the theory of compact translation surfaces and we refer the reader to the following four references when needed: A. Zorich [Zor06], J.-C. Yoccoz [Yoc10], G. Forni, C. Mathéus [FM14] or A. Wright [Wri15].

1.1.2 Three definitions

In this section we define what a translation surface is in three different ways. Each definition has its own pros and cons depending on the context in which translation surfaces are studied.

We start with the constructive definition, which generalizes the three examples we presented

Exercise 1.1.2

In this simple exercise we discuss the connectedness of M (in Definition 1.1.1) in terms of the combinatorics of the edge pairing. Let $(\mathcal{P}, f : E(\mathcal{P}) \rightarrow E(\mathcal{P}))$ be a family of polygons and a pairing, and let M be the translation surface obtained from the family of polygons \mathcal{P} . For each edge e we denote P_e the polygon in \mathcal{P} to which e belongs.

1. Prove that M is connected if and only if for each pair $P, Q \in \mathcal{P}$ there exists a finite sequence of polygons and edges $(P_{e_0}, e_0, P_{e_1}, e_1, \dots, e_{n-1}, P_{e_n})$ where $P_{e_0} = P$, $P_{e_n} = Q$ and for $i \in \{0, 1, \dots, n-1\}$ we have $P_{f(e_i)} = P_{e_{i+1}}$.
2. Show that the above property is equivalent to the connectivity of a graph built from (\mathcal{P}, f) and whose vertex set is the set of polygons \mathcal{P} .

The following lemma and exercise describe a translation surface around a vertex of finite degree.

Lemma 1.1.3. *Let M be the translation surface generated by a family of polygons \mathcal{P} . For each vertex $v \in P \in \mathcal{P}$ we denote by $\alpha_v \in (0, 2\pi)$ the interior angle of P at v . Then for each vertex $v \in P$ of finite degree there exists a positive integer $k_v \in \{1, 2, \dots\}$ so that*

$$\sum_{w \in \pi^{-1}(\pi(v))} \alpha_w = 2k_v\pi. \quad (1.1)$$

If $k_v > 1$, the point $\pi(v) \in M$ is called a conical singularity of angle $2k_v\pi$ while if $k_v = 1$ it is called a regular point.

Since the Euclidean metric $dx^2 + dy^2$ in the plane is invariant under translation, any translation surface built from polygons inherits an Euclidean metric that is well-defined in the complement of conical singularities. In particular, there is a well-defined notion of distance and area. The following elementary exercise describes the behavior of a metric at a vertex of finite degree.

Exercise 1.1.4

This exercise discusses conical singularities of an Euclidean metric. It is very much inspired on the first section of [Tro86]. We use x, y for the standard coordinates in \mathbb{R}^2 , $z = x + iy$ the corresponding number in \mathbb{C} and (r, θ) for polar coordinates $x = r \cos(\theta)$ and $y = r \sin(\theta)$ (or $z = r \exp(i\theta)$).

1. Show that the Euclidean metric $dx^2 + dy^2$ can also be written as $dzd\bar{z}$ or $(dr)^2 + (rd\theta)^2$.

Let us consider the punctured plane $\mathbb{C}^* = \mathbb{C} \setminus \{0\}$ with the metric $g_\alpha = (dr)^2 + (\alpha r d\theta)^2$ where $\alpha > 0$ is a parameter. The metric g_1 is nothing else than the Euclidean metric.

2. Show that a circle of radius $r > 0$ around the origin has length $2\pi r\alpha$ in the metric g_α .
3. Using the change of coordinates $\theta' = \alpha\theta$ show that g_α is a flat metric, *i.e.* a metric with zero curvature.
4. When $\alpha = k$ is a positive integer show that the map $z \mapsto z^k$ is a local isometry from (\mathbb{C}^*, g_k) to (\mathbb{C}^*, g_1) . Deduce that $g_k = |z|^{2(k-1)} dzd\bar{z}$.
5. Show that, for any $\alpha > 0$ the metric completion of \mathbb{C}^* with respect to g_α is the whole plane \mathbb{C} .
6. Show that the metric g_α extends to a metric on \mathbb{C} if and only if $\alpha = 1$.

The origin in \mathbb{C} is called a *conical point of angle $2\pi\alpha$* for the metric g_α . More generally, if S is a surface with a flat metric g defined on the complement of a discrete set Σ , we say that a point $p \in \Sigma$ is a *conical point of angle $2\pi\alpha$* for the metric g if there exists an open neighborhood U of p so that (U, g) is isometric to (D'_r, g_α) where $D'_r \subset \mathbb{C}$ is the punctured disc of radius r centered at the origin.

We now provide another construction of the cone (\mathbb{C}^*, g_α) .

7. Let m be the metric on \mathbb{C} defined by $m = |\exp(z)|^2 (dzd\bar{z})$. Show that the exponential map $\exp : \mathbb{C} \rightarrow \mathbb{C}^*$ is a local isometry between (\mathbb{C}, m) and (\mathbb{C}^*, g_1) .

8. Show that the translations by purely imaginary numbers are isometries in (\mathbb{C}, m) .
9. Show that the quotient $\mathbb{C}/(2\pi i\alpha\mathbb{Z})$ with the quotient metric \bar{m} is isometric to (\mathbb{C}^*, g_α) .
10. Show that the metric completion of (\mathbb{C}, m) is obtained by adding one point p_∞ . *Hint: p_∞ is the limit of any horizontal ray $z_t = -t + iy$ with $t \rightarrow +\infty$ and y fixed.*
11. Show that the map \exp extends to a map $\overline{\exp} : \mathbb{C} \cup \{p_\infty\} \rightarrow \mathbb{C}^* \cup \{0\}$.

The point p_∞ in (\mathbb{C}, m) is called an *infinite angle singularity*.

12. Let M be the translation surface generated by a family of polygons \mathcal{P} . Show that for each vertex of finite degree k_v , the point $\pi(v)$ is a conical point of angle $2k_v\pi$ of the Euclidean metric on M . *Hint: take a look at Lemma 1.1.3.*
13. Let M be the infinite staircase constructed in Section 1.1.1, show that each vertex give rise a point which is locally isometric to the infinite angle singularity p_∞ defined above.

Remark 1.1.5. The map $z \mapsto z^k$ considered in question 4 of Exercise 1.1.4 is actually the local model for ramified covers of surfaces.

We now consider the geometric definition of a translation surface. As we saw, a (constructive) translation surface carries a natural flat metric with conical singularities. However, as we will see later, not all surfaces with a flat metric are translation surfaces. The restriction is related to the so-called monodromy that will be discussed in Section 1.1.5. A *translation atlas* on a topological surface S is a set of maps $\mathcal{T} = \{\phi_i : U_i \rightarrow \mathbb{C}\}$ where $(U_i)_{i \in \mathbb{N}}$ forms an open covering of S , each ϕ_i is a homeomorphism from U_i to $\phi(U_i)$ and for each i, j the transition map $\phi_j \circ \phi_i^{-1} : \phi_i(U \cap V) \rightarrow \phi_j(U \cap V)$ is a translation in \mathbb{C} . Any topological surface with a translation atlas is naturally endowed with a flat metric. Indeed, this metric is obtained by pulling back the (translation invariant) Euclidean metric in \mathbb{C} .

Definition 1.1.6 (Geometric). A (*geometric*) *translation surface* is a pair (S, \mathcal{T}) made of a connected topological surface S and a maximal translation atlas \mathcal{T} on $S \setminus \Sigma$, where:

1. Σ is a discrete subset of S and
2. every $z \in \Sigma$ is a conical point.

The maximal translation atlas \mathcal{T} is called a *translation surface structure* on S and its charts are called the *flat charts* or *flat coordinates*.

Exercise 1.1.7

Prove that the angle of a conical point $z \in \Sigma$ in the definition above is of the form $2\pi k$, for some positive integer $k > 1$.

Remark 1.1.8. The pair $(S \setminus \Sigma, \mathcal{T})$ is a particular case of a (G, X) -structure in the sense of Thurston (see [Thu97]) where $G = \mathbb{C}$ is the group of translation acting on $X = \mathbb{C}$. In general, given an action of a group G on a topological space X one can consider a (G, X) -structure by considering atlases with values in X so that transition maps correspond to elements of G . One can think of this as gluing open sets of X with elements of G .

Finally, we introduce the analytic definition. It provides a tight link between translation surfaces, complex analysis and algebraic geometry that allows the use of very powerful tools. This third definition is central in many important results on compact translation surfaces such as the Eskin-Kontsevich-Zorich formula. The conformal structure already appears in the proof of Theorem 1.1.11 and will be important when we will study isometries in Section 3.1 or completeness of directional flows in Section 4.5. The Eskin-Kontsevich-Zorich formula will provide very explicit constants related to the diffusion in infinite coverings in Section 5.6. The reader not familiar with Riemann surfaces might choose to skip the sections using this point of view or consult one of the many textbooks available on the subject such as [For91], [FK92], [Don11] or [Hub06].

Definition 1.1.9 (Analytic). An (*analytic*) *translation surface* is a pair (X, ω) formed by a (connected) Riemann surface X and a holomorphic 1-form (*a.k.a.* Abelian differential) ω on X which is not identically zero.

Exercise 1.1.10

This exercise is a natural counterpart of Exercise 1.1.4.

1. Let (X, ω) be an analytic translation surface. Show that the tensor $dz\overline{dz}$ is a flat metric on $X \setminus Z(\omega)$ where $Z(\omega)$ is the set of zeros of ω and z is a local coordinate for X .
2. Show that each $p \in Z(\omega)$ is a conical point for the flat metric and determine the angle in terms of the order of p as a zero of ω . *Hint: there exists a non-negative integer k and a holomorphic coordinates z at p so that $\omega = z^k dz$.*

Notation disclaimer. Unless stated otherwise topological surfaces will be denoted by S , Riemann surfaces by X and translation surfaces by M .

1.1.3 Relations between the three definitions

Before diving in the geometry and dynamics of translation surfaces we prove in this section that the three definitions given above are equivalent.

Let M be a constructive translation surface built from a family $(\mathcal{P}, f : E(\mathcal{P}) \rightarrow E(\mathcal{P}))$. Given an edge $e \in E(\mathcal{P})$ belonging to the polygon P_e consider all possible triangles contained in P_e that have e as one of their edges and so that the third vertex is a vertex of P_e . This set of triangles is not empty and we denote it \mathcal{T}_e . Now, let (e, e') be a pair of identified edges and τ the translation so that $\tau(e') = e$. Let t and t' be respectively triangles in \mathcal{T}_e and $\mathcal{T}_{e'}$. Then $t \cup \tau(t') \subset \mathbb{C}$ is a planar quadrilateral and we denote by $V_{t,t'}$ its interior. Let also $U_{t,t'}$ be the interior of the image of $t \sqcup t'$ in M . We have a well defined bijection $\phi_{t,t'} : U_{t,t'} \rightarrow V_{t,t'}$.

The following result gathers the natural links between our three definitions.

Theorem 1.1.11

1. (*constructive are geometric*) Let M be a constructive translation surface. Denote by V and Σ the image of vertices in M and the conical singularities respectively (we have $\Sigma \subset V$). Then the maps $\{\phi_{t,t'}\}_{(t,t')}$ define a translation atlas on $M \setminus V$ that can be uniquely extended to a translation atlas on $M \setminus \Sigma$.
2. (*geometric are analytic*) Let (M, \mathcal{T}) be a geometric translation surface with conical singularities Σ . Then there is a unique holomorphic structure on M so that translation charts are holomorphic. Moreover, there is a unique Abelian differential ω so that for each translation chart $\phi : U \rightarrow V$ we have $\phi^* dz = \omega$.
3. (*analytic are geometric*) Let (X, ω) be an analytic translation surface and $Z(\omega)$ the set of zeros of ω . Then on $X \setminus Z(\omega)$ the local coordinates z so that $\omega = dz$ define a translation atlas on $X \setminus Z(\omega)$.
4. (*geometric are constructive*) Every geometric translation surface (M, \mathcal{T}) can be obtained from a family and pairing $(\mathcal{P}, f : E(\mathcal{P}) \rightarrow E(\mathcal{P}))$.

Proof. **1. Constructive are geometric.** The domains $U_{t,t'}$ of the maps $\phi_{t,t'}$ form by definition an open cover of $M \setminus V$. It is also clear that the transition maps between the $\phi_{t,t'}$ are translations. Now, it follows from the questions 6 and 12 of Exercise 1.1.4 that each point in $V \setminus \Sigma$ (i.e. vertex of conical angle 2π) has a neighborhood isometric to a flat disk. This isometry is the unique way of extending the atlas.

2. Geometric are analytic. Let (M, \mathcal{T}) be a geometric translation surface. Since translations are holomorphic maps, the translation surface structure in $M \setminus \Sigma$ is also a Riemann surface structure. By holomorphic continuation, the Riemann structure is unique at each point of Σ (recall that Σ is discrete by assumption). Now, in each chart we can pull back the Abelian differential dz from the plane. Because dz is invariant under translation, these pull-backs agree on the intersection of the domains of two flat charts and merge into a globally well-defined holomorphic 1-form ω on $M \setminus \Sigma$. Note that this 1-form is nowhere zero. Exercise 1.1.10 explains why a conical singularity of angle $2k_v\pi$ corresponds to a zero of degree $v_k - 1$ of the differential ω .

3. Analytic are geometric. Given an analytic translation surface (X, ω) , the integration of ω on $X \setminus Z(\omega)$ endows $X \setminus Z(\omega)$ with an atlas where transition functions are translations. Indeed, define the

chart $\varphi : U \subset X \rightarrow \mathbb{C}$ by $\varphi(p) = \int_{p_0}^p \omega$, where $p_0 \in U$ and U is a simply connected neighbourhood. Now consider another chart $\psi : V \subset X \rightarrow \mathbb{C}$ defined by $\int_{q_0}^p \omega$ (V also simply connected), where $p \in U \cap V$ and the constant $C = \int_{p_0}^{q_0} \omega$. The equation $\int_{p_0}^{q_0} \omega = \int_{p_0}^p \omega + \int_p^{q_0} \omega$ implies that the defined charts are related by a translation: $\varphi(p) = \psi(p) + C$. The relation between the zeros of ω and the conical singularities can again be deduced from Exercise 1.1.10.

4. Geometric are constructive. We now turn to the delicate point of the proof. In what follows we show that every geometric translation surface admits a triangulation \mathfrak{T} whose 1-skeleton in flat coordinates is made of Euclidean segments and whose 0-skeleton contains the set of conical singularities Σ . The existence of such a triangulation implies that the geometric translation surface can be constructed using Euclidean polygons and hence it is a constructive surface.

Let (M, \mathcal{T}) be a geometric translation surface with conical singularities Σ . We decompose the proof in two steps.

1. First we show that $M \setminus \Sigma$ admits a triangulation \mathfrak{T}' whose 1-skeleton is formed (in flat coordinates) by Euclidean segments.
2. Next, we explain how the triangulation \mathfrak{T}' can be refined in order to obtain a (flat) triangulation \mathfrak{T} of M such that Σ is contained in the vertices of \mathfrak{T} .

Step 1. We already know that M inherits a Riemann structure from item 3. Hence there exists a triangulation \mathfrak{T}'' of M whose edges are smooth and vertices have finite degree (see [AS60] for a proof that this triangulation always exists). We can assume that the vertices of \mathfrak{T}'' are disjoint from Σ using an homotopy. Now we modify \mathfrak{T}'' to obtain the triangulation \mathfrak{T}' as follows:

1. Let $Sk_n(\mathfrak{T}'')$ denote the $n = 0, 1, 2$ skeletons of \mathfrak{T}'' (i.e., vertices, edges and faces). Every vertex $p \in Sk_0(\mathfrak{T}'')$ is in the domain of a translation chart $\phi_p : U_p \rightarrow \mathbb{C}$ whose image is a disk and such that $U_p \cap Sk_0(\mathfrak{T}'') = p$. Since $Sk_0(\mathfrak{T}'')$ is a discrete subset of M , we can further assume that $U_p \cap U_q = \emptyset$ for every $p \neq q$ in $Sk_0(\mathfrak{T}'')$. By compactness $\phi_p(U_p \cap Sk_1(\mathfrak{T}''))$ consists of finitely many smooth arcs γ_j from $\phi_p(p)$ to the boundary and smooth arcs η_j from the boundary to the boundary. We can thus replace each γ_j by a radius from $\phi_p(p)$ to the boundary of $\phi_p(U_p)$ and each η_j by a chord c_j disjoint from all radii. Moreover, given that $\phi_p(U_p)$ is a disk, we can choose these chords so that $c_i \cap c_j = \emptyset$, for all $i \neq j$.
2. Let us denote by $U = \cup_{p \in Sk_0(\mathfrak{T}')} U_p$, where U_p is the disk chosen in the previous step. For every edge $e \in Sk_1(\mathfrak{T}')$ the subset $e \setminus U$ can be covered by finitely many open discs $D_1^e, \dots, D_{m_e}^e$, each of which is the domain of a flat chart and which together form a chain, that is:
 - (a) $D_j \cap U \neq \emptyset$ if and only if $j = 1$ or $j = m_e$.
 - (b) For every $j = 2, \dots, m_e - 1$, $D_j \cap D_l \neq \emptyset$ if and only if $l = j \pm 1$,
 - (c) There are no three discs in $\{D_1^e, \dots, D_{m_e}^e\}$ sharing a common point,
 - (d) For every $j = 1, \dots, m_e$, the intersection $e \cap D_j$ is non-empty smooth-connected arc.

The intersection $e \cap (\cup_{j=1}^{m_e} \partial D_j)$ defines a finite sequence of points p_1, \dots, p_{2m_e} . Since the collection of disks is finite and disks are convex, we can replace as in the previous step the arc between p_i and p_{i+1} by a straight line segment.

Step 2. The second step is a consequence of the following lemma.

Lemma 1.1.12. *Let M be a simply connected compact translation surface with a boundary that consists of finitely many Euclidean segments. Then M admits a triangulation whose edges are Euclidean segments and whose vertices are exactly the vertices on the boundary and the singularities.*

The proof we propose, which is elementary, uses concepts that we have not introduced yet. Therefore we address it in Section 4.1.1, p. 87. \square

1.1.4 Half-translation surfaces

Translation surfaces are part of a bigger class of surfaces called *half-translation surfaces* or *quadratic differentials*². Before giving any formal definition let us consider the example of the surface M depicted

²Some authors use the misleading term *flat surface*: a flat Riemannian metric on a surface does not necessarily come from a quadratic differential.

in Figure 1.3. This surface is obtained by gluing 3 squares along their sides using isometries *that respect the orientations shown in the figure*. In particular, the isometry used to glue the sides C_1 and C_2 is the composition of $z \rightarrow -z$ with a translation. Following tradition, we call these kind of isometries *half-translations*. On the other hand, the sides A and B are glued by translation. A direct calculation of the Euler characteristic shows that M is a torus. The vertices of the three squares merge into three points p_1, p_2 and p_3 in the surface M . The points p_1 and p_2 are conical points of angle π , in the sense of Exercise 1.1.4. Indeed, these points have neighbourhoods that can be constructed from a half-disc by gluing opposite radii using a half-translation. On the other hand, p_3 is a conical singularity of angle 4π .

Now let us introduce a more formal definition. Consider a pairing $f : E(\mathcal{P}) \rightarrow E(\mathcal{P})$ such that for every $e \in E(\mathcal{P})$ the edges e and $e' = f(e)$ differ by a translation. The first difference with the definition of a translation surface is that now there are two possible cases to consider: (i) $n_{e'} = -n_e$ and (ii) $n_{e'} = n_e$. We identify the points in e with the points in $f(e)$ in case (i) using τ_e and in case (ii) using τ_e followed by $z \rightarrow -z$. Let $\pi : \bigsqcup_{P \in \mathcal{P}} P \rightarrow (\bigsqcup_{P \in \mathcal{P}} P) / \sim$ the corresponding quotient map.

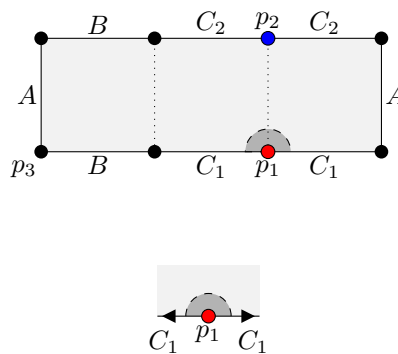

Figure 1.3: A genus 1 translation surface and a neighbourhood of a conical point of angle π (corresponding to a simple pole of the quadratic differential).

Definition 1.1.13 (Constructive). Let \mathcal{P} be an at most countable set of Euclidean polygons and $f : E(\mathcal{P}) \rightarrow E(\mathcal{P})$ a pairing as above. Let M be $\bigsqcup_{P \in \mathcal{P}} P / \sim$ deprived of all vertices of infinite degree and vertices that define a conical singularity of angle π . If M is connected we call it *the half-translation surface generated by the family of polygons \mathcal{P}* .

Definition 1.1.14 (Geometric). A (geometric) half-translation surface is a pair (S, \mathcal{T}) made of a connected topological surface S and a maximal *half-translation atlas* on $S \setminus \Sigma$, where:

1. Σ is a discrete subset of S and
2. every $z \in \Sigma$ is a conical point whose angle is larger than or equal to 2π .

A half-translation atlas is just as a translation atlas, except that we allow change of coordinates to be half-translations. Given that the Euclidean metric in \mathbb{C} is also invariant by half-translations, every geometric half-translation surface inherits a natural Riemannian metric from the plane by pull-back via its flat coordinates.

Finally, we define flat surfaces analytically.

Definition 1.1.15 (Analytic). An (*analytic*) half-translation surface is a pair (X, q) formed by a (connected) Riemann surface X and a *holomorphic* non-zero quadratic differential q .

Remark 1.1.16. In this text we consider sometimes pairs (X, q) formed by a (connected) Riemann surface X and a *meromorphic* non-zero quadratic differential q whose poles are all simple, if any. Every such pair defines the half-translation surface $(X \setminus Poles(q), q)$. The convention made in this text is *not to consider simple poles (or equivalently conical singularities of angle π) as part of a half-translation surface*. The reasons behind this convention are rather technical, but will be clarified to the reader when the necessary material has been introduced³.

Let us now explain how quadratic differentials define geometric half-translation surfaces. Let $\{(U_i, z_i)\}_{i \in I}$ be an atlas for the Riemann surface structure of X and recall that q is just a collection of expressions $\{f_i(z_i)dz_i^2\}_{i \in I}$, where f_i are holomorphic functions and these in $U_i \cap U_j$ satisfy:

$$f_i(z_i(z_j)) \left(\frac{dz_i}{dz_j} \right)^2 = f_j(z_j). \tag{1.2}$$

³Two examples of these technical reasons are: core curves of cylinders in a sphere with a meromorphic quadratic differential where poles have not been removed are always null-homotopic; for any finite-type hyperbolic Riemann surface, the cotangent space of Teichmüller space (at a point) is identified with the space of integrable *holomorphic* quadratic differentials, see Proposition 6.6.2 in [Hub06].

We denote by $Z(q)$ the set of zeroes of q in X . The key point is to look for the local coordinate ξ on $X \setminus Z(q)$ such that $q = d\xi^2$. Indeed, for every $p \in X \setminus Z(q)$ there exists a neighbourhood $U_i = U_i(p)$ on which a square root of f_i exists. If we define for every $z \in U_i$

$$\xi_i(z) = \int_p^z \sqrt{f_i(w)} dw. \quad (1.3)$$

this coordinate satisfies $q = d\xi_i^2$ on U_i . Moreover, since we had to make a choice for the square root of f , the coordinate $\xi_i(z)$ is unique up to translation and change of sign. In other words, the coordinates $\xi_i(z)$ define an atlas on $X \setminus Z(q)$ where transition functions are of the form $z \rightarrow \pm z + a$. That is, $\{(U_i, \xi_i)\}_{i \in I}$ is a half-translation atlas.

On the analytic side, an Abelian differential ω is just turned into a quadratic differential by considering $q = \omega^2$. However, not every quadratic differential is globally the square of an Abelian differential (e.g. $dz^2/(z(z+1)(z-1))$ on $\mathbb{C} \setminus \{0, 1, -1\}$).

Exercise 1.1.17

Show that the three definitions of half-translation surface that we have given above are equivalent.
Hint: the proof is *mutatis mutandis*, the same as the proof of theorem 1.1.11.

Exercise 1.1.18

This exercise discusses conical singularities of half-translation surfaces.

1. Let M be a geometrical half-translation surface. Prove that the angle of a conical point $z \in \Sigma$ in the definition above is of the form πk for some positive integer $k \geq 2$.
2. Let (X, q) be an analytic half-translation surface and $z_0 \in Z(q)$ a zero of multiplicity $k \geq 1$. Show that z_0 in flat coordinates is a conical point of total angle $(k+2)\pi$.
3. Let M be a constructive half-translation surface and v a vertex of a polygon in \mathcal{P} . Prove that there exist a positive integer $k_v \geq 2$ for which the following analog of equation (1.1) holds:

$$\sum_{w \in \pi^{-1}(\pi(v))} \alpha_w = k_v \pi. \quad (1.4)$$

Orientation double covering. Let $M = (X, q)$ be a half-translation surface and suppose that q is not the square of an Abelian differential. In the next paragraphs we explain how to construct a canonical (ramified) double covering $\pi : M^2 \rightarrow M$ such that $\pi^*q = \omega^2$, where ω is an Abelian differential on M^2 .

As before, let $\{(U_i, \xi_i)\}_{i \in I}$ be the half-translation atlas defined by the local integration of q on $X \setminus Z(q)$. Recall that q is given locally by $\{f_i dz_i^2\}_{i \in I}$ satisfying (1.2) in $U_i \cap U_j$. Given that for every f_i has no zeroes on U_i (we have restricted the discussion to $X \setminus Z(q)$), we can consider for each $i \in I$, $g_i^+(z_i)$ and $g_i^-(z_i)$ two branches of the square root of f_i on U_i . Consider also two copies U_i^+ and U_i^- of U_i , which we think of as the domain of $g_i^+(z_i)$ and $g_i^-(z_i)$ respectively. We define the double covering M^2 locally as follows. Suppose that $U_i \cap U_j \neq \emptyset$ and let $\pi_{i,\pm} : U_i^\pm \rightarrow U_i$ be the natural projections. We identify $\pi_{i,+}^{-1}(U_i \cap U_j)$ with $\pi_{j,+}^{-1}(U_i \cap U_j)$ and $\pi_{i,-}^{-1}(U_i \cap U_j)$ with $\pi_{j,-}^{-1}(U_i \cap U_j)$ using the maps $\pi_{j,+}^{-1} \circ \pi_{i,+}$ and $\pi_{j,-}^{-1} \circ \pi_{i,-}$ respectively if

$$g_i^+(z_i(z_j)) \cdot \frac{dz_i}{dz_j} = g_j^+(z_j). \quad (1.5)$$

On the other hand, if $g_i^+(z_i(z_j)) \cdot \frac{dz_i}{dz_j} = g_j^-(z_j)$ we identify $\pi_{i,+}^{-1}(U_i \cap U_j)$ with $\pi_{j,-}^{-1}(U_i \cap U_j)$ and $\pi_{i,-}^{-1}(U_i \cap U_j)$ with $\pi_{j,+}^{-1}(U_i \cap U_j)$ using the maps $\pi_{j,-}^{-1} \circ \pi_{i,+}$ and $\pi_{j,+}^{-1} \circ \pi_{i,-}$ respectively. These gluings define an open Riemann surface \tilde{M}^2 which is a (non-ramified) double covering of $X \setminus Z(q)$. The collection of expressions $\{g_i^\pm dz_i\}_{i \in I}$ defines a holomorphic 1-form ω on \tilde{M}^2 that can be holomorphically extended to a (possibly ramified) covering $\pi : M^2 \rightarrow M$. Moreover, by construction $\pi^*q = \omega^2$ and $Z(q)$ in the locus on M where the covering might be ramified.

Exercise 1.1.19

Let $M = (X, q)$ be half-translation surface, $\pi : M^2 \rightarrow M$ its orientation double covering and suppose that $z_0 \in X$ is a zero of q of order $\kappa \geq 1$. Prove that if κ is even, then $\pi^{-1}(z_0)$ is formed by two conical points of total angle $\pi \frac{\kappa}{2}$. Prove that if κ is odd, then $\pi^{-1}(z_0)$ is just a conical point of total angle $\pi(\kappa + 1)$. Deduce that the ramification points of the orientation double cover are the zeroes of odd degree of the quadratic differential q .

We finish this section presenting a way to define the double covering M^2 that only uses the half-translation atlas and elementary algebraic topology. Most of the details are left to the reader on exercise 1.1.20. The idea is to use the *holonomy* of the half-translation structure (defined in the next paragraph): this is a morphism $\hat{f} : \pi_1(x_0, M \setminus \Sigma) \rightarrow \{+1, -1\}$ whose kernel defines a regular covering of $M \setminus \Sigma$ and the completion of this covering to a ramified covering is precisely M^2 . The concept of holonomy is more general than the one we present in this section. As we will see later, one can also talk about the holonomy of a (G, X) -structure or the holonomy of a compact translation surface on moduli space (*i.e.* Konsevich-Zorich's cocycle).

Let $\gamma : [0, 1] \rightarrow M$ be a closed loop. Then there exists a finite set of charts $\xi_0 : U_0 \rightarrow \mathbb{C}, \xi_1 : U_1 \rightarrow \mathbb{C}, \dots, \xi_n : U_n \rightarrow \mathbb{C}$ and real numbers $t_0 = 0 < t_1 < \dots < t_n = 1$ so that $\{\gamma(t)\}_{t \in [t_i, t_{i+1}]} \subset U_i$. On each intersection $U_i \cap U_{i+1}$ the linear part of the transition map $\xi_{i+1} \circ \xi_i^{-1}|_{U_i \cap U_{i+1}}$ is either $+1$ or -1 . Let s_i be this sign. We set $f(\gamma) = s_0 s_1 \dots s_n$.

Exercise 1.1.20

Show that the map f defined above defines a map $\hat{f} : \pi_1(x_0, M) \rightarrow \{+1, -1\}$. This map is called *the holonomy of the flat structure on M* .

1. Show that the half-translation atlas of M contains a translation atlas if and only if the image of f is $\{+1\}$.
2. If the half-translation atlas of M contains a translation atlas show that it contains exactly two.
3. Show that the double (regular) covering $M^2 \rightarrow M \setminus \Sigma$ given by the subgroup $\ker \hat{f}$ can be endowed with a translation surface structure. Show that this double regular covering can be extended to a possibly ramified covering $\pi : M^2 \rightarrow M$ and that the ramification locus of π is contained in Σ .
4. If M comes from a holomorphic quadratic differential (X, q) show that the surface defined by the equation $\{\omega \in T^*(X) : \omega^2 = q\}$, where $T^*(X)$ is the (complex) cotangent space of X , carries a canonical translation surface structure.

In Figure 1.4 we depict an example of an orientation double covering.

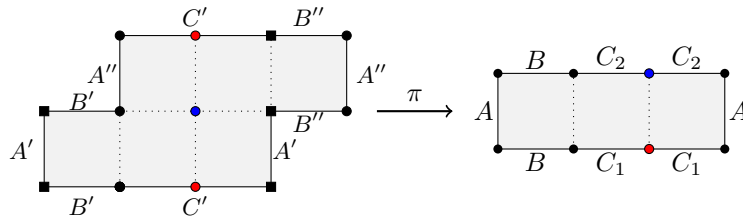

Figure 1.4: The orientation double covering of the half-translation surface of Figure 1.3.

1.1.5 Structures

In this section we discuss the most important structures and invariants that one can associate to a translation (or half-translation) surface. The material we present will be illustrated with several examples in the following sections of this chapter. We stress that this material is standard in the context of *compact*

translation surfaces, as discussed in several different surveys on the subject such as A. Zorich [Zor06], J.-C. Yoccoz [Yoc10], G. Forni, C. Mathéus [FM14] or A. Wright [Wri15].

Metric completion and singularities. Let M be a translation or half-translation surface and $\Sigma \subset M$ its conical singularities. As discussed in the preceding section, $M \setminus \Sigma$ can be naturally endowed with a flat Riemannian metric μ which provides a canonical notion of distance (given by the induced intrinsic metric) and area. We denote by \widehat{M} the metric completion of $M \setminus \Sigma$ w.r.t. the intrinsic metric induced by μ .

Exercise 1.1.21

Let M be a translation or half-translation surface. Show that:

1. M is canonically embedded in \widehat{M} and the image of this embedding is dense in \widehat{M} .
2. Suppose that $M = (X, q)$ is a half-translation surface and that q can be meromorphically extended to a point $z_0 \in \widehat{M}$. Show that if q is not holomorphic at z_0 , then this point is a simple pole and that the Euclidean metric of M can be extended to z_0 . Show that in the case where z_0 is a simple pole this point is a conical point of angle π .
3. If M is constructed from a family of polygons \mathcal{P} , show that there is an inclusion $(\bigsqcup_{P \in \mathcal{P}} P / \sim) \hookrightarrow \widehat{M}$. In other words: show that all vertices need to be added to obtain the metric completion of a constructive translation surface. Show also that the total area of M w.r.t to the Riemannian metric μ is the sum of the areas of the polygons in \mathcal{P} .

Given that the translation (or half-translation) surface structure is not defined at conical points, it is in the metric completion where one finds the singularities of the structure. For the following definition we refer to exercise 1.1.4.

Definition 1.1.22 (Conical, infinite angle and wild singularities). Let M be a translation or half-translation surface and \widehat{M} its metric completion with respect to the natural flat metric. A point $p \in \widehat{M} \setminus M$ is called:

1. *regular* if it has a neighbourhood isometric to an open disc in the plane,
2. a *conical singularity* if p is a conical point which is not regular,
3. an *infinite angle singularity* if there exists a punctured neighbourhood U^* of p in \widehat{M} which is isometric to a punctured neighbourhood of p_∞ in (\mathbb{C}, m) , and
4. a *wild singularity* if p is none of the above.

The subset of \widehat{M} formed by all conical, infinite angle and wild singularities is called *the set of singularities of M* and will be denoted by $\text{Sing}(M)$. A translation surface is called *tame* if $\text{Sing}(M)$ is formed exclusively by conical and infinite angle singularities, and *wild* in all other cases.

Loosely speaking, conical singularities appear in translation or half-translation surfaces “by default”⁴. On the other hand, wild and infinite angle singularities only appear in the metric completion, as in the case of the infinite staircase. As we see later with the example of baker’s surface (see section 1.2.2) wild singularities naturally appear in translation surfaces of finite area and infinite genus. We study singularities of translation surfaces in detail in chapter 2.3.

Remark 1.1.23. The set of wild singularities can be disjoint from the set of vertices on a constructive translation surface. Indeed, it is not difficult to construct an infinite triangulation \mathfrak{T} of the (open) unit disc $\mathbb{D} = \{z \in \mathbb{C} \mid |z| < 1\}$. Every vertex of \mathfrak{T} is properly contained in \mathbb{D} , however $\text{Sing}(\mathbb{D}) = \{z \in \mathbb{C} \mid |z| = 1\}$.

Infinite type. A translation surface is compact if and only if can be built from finitely many polygons. We introduce a slightly more general notion (finite type) which allows us to define the main objects of study of this book.

⁴Except for conical singularities of angle π , see Remark 1.1.16.

Definition 1.1.24. Let $M = (X, \omega)$ be a translation surface. We say that M is of *finite type* if M has finite area and X is a *finite-type* Riemann surface. If M is not of finite type we say it is of *infinite type*.

Remark 1.1.25. Recall that a Riemann surface X has *finite type* if it is isomorphic (as Riemann surface) to a compact Riemann surface to which we have removed a finite set of points. For example, the plane \mathbb{C} is of finite type (as it is the sphere $\widehat{\mathbb{C}}$ minus one point) whereas the unit disk \mathbb{D} is not. In particular, we stress that the fundamental group of X does not play a role in definition 1.1.24. However, a translation surface M whose fundamental group is not finitely generated is of infinite type.

To define half-translation surface of finite type just change ω by q (a quadratic differential) in the preceding definition. In Section 1.2.5 we show there are examples of infinite-type half-translation surfaces of the form $(\mathbb{C} \setminus \Lambda, q)$, where Λ is a lattice, with interesting dynamical properties.

Affine maps. Let M and M' be translation surfaces with conical singularities Σ and Σ' respectively. A map $f : M \rightarrow M'$ such that $f(\Sigma) \subset \Sigma'$ is called an *affine map* if $f : M \setminus \Sigma \rightarrow M' \setminus \Sigma'$ in flat charts is an \mathbb{R} -affine map. That is, if z (respectively z') denotes a flat local coordinate of $M \setminus \Sigma$ (resp. $M' \setminus \Sigma'$) and we write $z = x + iy$ (resp. $z' = x' + iy'$) then f in these coordinates is given by an expression of the form:

$$\begin{pmatrix} x \\ y \end{pmatrix} \mapsto \begin{pmatrix} x' \\ y' \end{pmatrix} = \begin{pmatrix} a & b \\ c & d \end{pmatrix} \begin{pmatrix} x \\ y \end{pmatrix} + \begin{pmatrix} x_0 \\ y_0 \end{pmatrix}. \quad (1.6)$$

Since two coordinates differ only by a translation, the matrix $\begin{pmatrix} a & b \\ c & d \end{pmatrix}$ does not depend on the coordinates z and z' . However, the translation vector $\begin{pmatrix} x_0 \\ y_0 \end{pmatrix}$ does. We will denote the constant derivative of an affine map f by Df .

Definition 1.1.26. Let M and M' be two translation surfaces. An affine map $f : M \rightarrow M'$ is called a *translation* if $Df = 1$ and an *isometry* if $Df \in \mathrm{SO}(2, \mathbb{R})$.

The translation surfaces M and M' are called *isomorphic* if there exists a 1-to-1 translation $f : M \rightarrow M'$.

Note that translation and isometries are special cases of volume preserving affine maps (i.e. with $\det(Df) = \pm 1$).

An *affine automorphism* is a homeomorphism $f : M \rightarrow M$ which is also an affine map. We denote by $\mathrm{Aff}(M)$ the group of affine homeomorphisms of M and by $\mathrm{Aff}^+(M)$ the subgroup of $\mathrm{Aff}(M)$ made of orientation preserving affine automorphisms (i.e. their linear part has positive determinant). The derivative Df of an affine map lives in $\mathrm{GL}(2, \mathbb{R})$ and the derivation provides a group morphism $D : \mathrm{Aff}(M) \rightarrow \mathrm{GL}(2, \mathbb{R})$. We denote by $\mathrm{Trans}(M)$ (resp. $\mathrm{Isom}(M)$) the groups formed by all affine automorphisms of M which are translations (resp. isometries).

Definition 1.1.27. The image of the group morphism $D : \mathrm{Aff}^+(M) \rightarrow \mathrm{GL}(2, \mathbb{R})$ is called the *Veech group* of the translation surface M . We denote it by $\Gamma(M)$.

We study Veech groups of infinite type translation surfaces in detail in section 3.2. As the next definition shows, one can classify orientation and volume preserving affine automorphisms using their derivatives.

Definition 1.1.28. An orientation and volume preserving affine automorphism $f : M \rightarrow M$ (i.e. so that $\det(Df) = 1$) is called *elliptic* if $|\mathrm{tr}(Df)| < 2$, *parabolic* if $|\mathrm{tr}(Df)| = 2$ and *hyperbolic* if $|\mathrm{tr}(Df)| > 2$. In the case M is a compact translation or half-translation surface, an affine hyperbolic automorphism is called an *affine pseudo-Anosov homeomorphism*.

This nomenclature mimics the one used for matrices in $\mathrm{SL}(2, \mathbb{R})$. Remark that an automorphism is elliptic if and only if it is an isometry. Note that there are several equivalent definitions of what a pseudo-Anosov homeomorphism is (see e.g. [Thu88], [FLP79] or [FM12]). We discuss affine automorphism groups in detail in Chapter 3.

GL(2, \mathbb{R})-action. There is a natural action of the group $\mathrm{GL}(2, \mathbb{R})$ on the set of all translation surfaces, which is easily defined as follows: if (S, \mathcal{T}) is a geometric translation surface, $\mathcal{T} = \{\phi_i : U_i \rightarrow \mathbb{C}\}_{i \in I}$ and $A \in \mathrm{GL}(2, \mathbb{R})$, then $A(S, \mathcal{T}) = (S, A\mathcal{T})$, where $A\mathcal{T} = \{A \circ \phi_i : U_i \rightarrow \mathbb{C}\}_{i \in I}$. Remark that $A\mathcal{T}$ is indeed a translation atlas for:

$$(A \circ \phi_j) \circ (A \circ \phi_i)^{-1} = A \circ (\phi_j \circ \phi_i^{-1})(A^{-1}(z)) = A(A^{-1}(z) + c) = z + A(c)$$

In the context of finite-type translation surfaces, this action is a fundamental ingredient for the study of the dynamics of the translation flow, which we define in the next paragraphs. For a detailed discussion of this action in the context of finite-type surfaces see Section 3 in [Wri15].

Translation flow. For each direction $\theta \in \mathbb{R}/2\pi\mathbb{Z}$ we have well-defined translation flow $F_{\mathbb{C},\theta}^t : \mathbb{C} \rightarrow \mathbb{C}$ given by $F_{\mathbb{C},\theta}^t(z) = z + te^{i\theta}$, which is the one-parameter flow corresponding to the integration of the constant (real) vector field $e^{i\theta}$ on \mathbb{C} . Now, let M be a translation surface. The pull-back of this vector field through flat charts is well-defined on $M \setminus \text{Sing}(M)$ and the associated flow is called the *translation flow of M in direction θ* . We will abuse notation and denote the vector field and corresponding flow on M by $e^{i\theta}$ and $F_{M,\theta}^t$ respectively. When there is no need to distinguish translation flows in different translation surfaces we abbreviate $F_{M,\theta}^t$ by F_{θ}^t .

Remark that $e^{i\theta}$ is only defined on the complement in M of conical singularities. In particular $F_{M,\theta}^t$ is not quite a flow $t \in \mathbb{R}$, for it might hit a conical singularity in finite time. Though, for a large class of surfaces the translation flow is defined almost everywhere with respect to the area. The term *translation flow* (i.e. without specifying the direction) is reserved for $F_{M,\pi/2}^t$, that is, the translation flow in the vertical direction and is abbreviated by $F_{\pi/2}^t$ or simply by F^t when all other variables in the context are clear. Note that the (vertical) translation flow in the rotated surface $M' = (X, e^{-i\theta}\omega)$ is the same flow as the translation flow in direction $\theta + \frac{\pi}{2}$ in $M = (X, \omega)$. In other words, $F_{e^{-i\theta}M, \frac{\pi}{2}}^t = F_{M, \theta + \frac{\pi}{2}}^t$.

When M has finite type, for all directions θ , the set of points in for which $F_{M,\theta}^t$ is defined for all times forms a subset of full Lebesgue measure. Abusing language, we will say that such a flow is *complete*. In Chapter 4 we will discuss under which conditions the translation flow in a non-compact translation surface is complete. The flat disk (\mathbb{D}, dz) is an example where the flow is not complete in any direction.

The translation flow in any direction θ also preserves the (flat) Riemannian metric μ on M . In particular, where it is defined, it preserves the area: if $A \subset M$ and $F_{M,\theta}^t$ is well defined on A then the area of A and $F_{M,\theta}^t(A)$ are identical. For this reason many tools from ergodic theory are available to study translation flows. Because of the presence of conical singularities, in general the translation flow does not act by isometries. The dynamical properties of translation flows are studied in chapters 4, 5 and 6.

Remark 1.1.29. Let M be a translation surface and $T_1(M)$ the unit tangent bundle of $M \setminus \text{Sing}(M)$ w.r.t. the natural flat metric μ . Given that all coordinate changes are translations this bundle is trivial, i.e. $T_1(M) \simeq M \times \mathbb{R}/2\pi\mathbb{Z}$. Moreover, this isomorphism is canonical: the vector field corresponding to $e^{i\theta}$ considered above gives the slice $M \times \{\theta\}$ in this product. Now, the geodesic flow G^t on $T_1(M)$ in these product coordinates is just $G^t : (z, \theta) \mapsto (F_{M,\theta}^t(z), \theta)$. In other words, the 3-dimensional unit tangent bundle $T_1(M)$ is foliated by copies of M which are invariant by the geodesic flow. On each invariant surface G^t is canonically identified to a translation flow on M .

Recall that, given a flat surface $M = (X, q)$, the local coordinates z for which the quadratic differential satisfies $q = (dz)^2$ are well defined up to a sign. For this reason the pull back of the vector field $e^{i\theta}$ to M cannot define a global vector field on M . On the other hand, this pull back does define a *direction field* (in the sense of V.I. Arnold, see [Arn06]) and the corresponding set of integral curves a foliation on $M \setminus Z(q)$ by curves which locally look like straight line segments. On the other hand, the pull back of the vector field $e^{i\theta}$ to the canonical double cover M^2 does define a global vector field which projects onto the direction field on M .

Cylinders and strips. There are two kind of subsets that a translation surface might have and whose mere existence guarantees that the translation flow in certain directions, restricted to these subsets, is simple. These subsets are cylinders and (infinite) strips.

Definition 1.1.30 (Cylinders and strips). A *horizontal cylinder* $C_{c,I}$ is a translation surface of the form $([0, c] \times I) / \sim$, where $I \subset \mathbb{R}$ is open (but not necessarily bounded), connected, and where $(0, s)$ is identified with (c, s) for all $s \in I$. The numbers c and $h = |I|$ are called the *circumference* and *height* of the cylinder respectively. A *horizontal strip* $C_{\infty,I}$ is a translation surface of the form $\mathbb{R} \times I$, where I is a bounded open interval. Analogously, the height of the horizontal strip is $h = |I|$.

An open subset of a translation surface M is called a *cylinder* (respectively a *strip*) in direction θ if it is isomorphic to $e^{-i\theta}C_{c,I}$ (respect. to $e^{-i\theta}C_{\infty,I}$).

One can think of strips as cylinders of infinite circumference and finite height. For flat surfaces $M = (X, q)$ the definition of cylinder still makes sense, though its direction is well defined up to change of sign. Examples of cylinders are illustrated in figure 1.5.

Exercise 1.1.31

Let M be a translation surface.

1. Show that a cylinder in direction θ of M is made of periodic trajectories of $F_{M,\theta}^t$ whose lengths are the circumference of the cylinder.
2. Conversely, show that every periodic trajectory of $F_{M,\theta}^t$ is contained in a maximal cylinder.

hint: if $x \in M$ is a point where the translation flow $F_{M,\theta}^t$ is defined for some time in the past and in the future, then x is the center of a neighbourhood in M formed by points with this property.

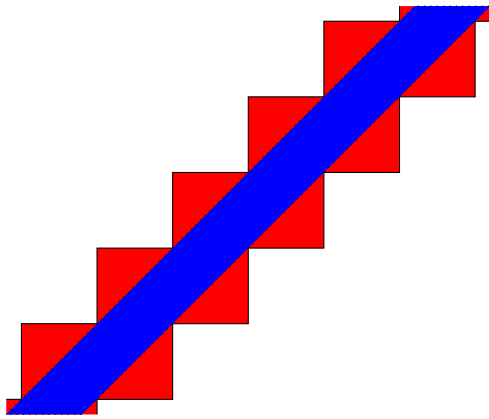

(a) Infinite strips in the infinite staircase from Figure 1.2.

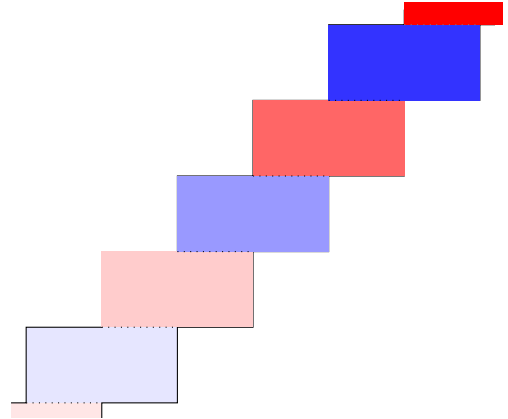

(b) Cylinders in the horizontal direction in the infinite staircase.

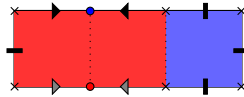

(c) Two vertical cylinders in the genus 1 half-translation surface from Figure 1.3.

Figure 1.5: Cylinders and strips in translation and flat surfaces.

Strata of finite-type translation surfaces. In this paragraph we review without details the definition of strata of finite-type translation surfaces. The reader is invited to consult details in [Zor06, Section 3.3], [?, Section 2.3] (analytic version) and [Yoc10, Section 6] (constructive version).

All singularities of a finite-type translation surface are of finite angle. In particular one can define appropriate moduli spaces for the set of equivalence classes of translation surfaces (or quadratic differentials). If $\kappa_1, \kappa_2, \dots, \kappa_m$ are non-negative integers then $\mathcal{H}(\kappa_1, \kappa_2, \dots, \kappa_m)$ denotes the set of tuples (M, p_1, \dots, p_m) where M is a translation surface (up to isomorphism) with conical singularities of angles $2(1 + \kappa_1)\pi, 2(1 + \kappa_2)\pi, \dots, 2(1 + \kappa_m)\pi$ at the (distinct and enumerated) points $(p_i)_{i=1}^m$ respectively. This set is called a *stratum* of translation surfaces and, from Riemann-Hurwitz theorem, one can deduce that all surfaces in a stratum have the same genus g given by the equation $\sum_{i=1}^m \kappa_i = 2g - 2$. For example, the translation surface depicted in Figure 1.1 is a point in $\mathcal{H}(2)$. When $\kappa_i = 0$ the point p_i is a flat point: $\mathcal{H}(2, 0)$ is the stratum of translation surfaces with one cone angle singularity of angle 6π and one marked point (hence genus 2). Strata have a nice complex orbifold structure given by period coordinates. These coordinates allow to define the Masur-Veech measure on strata, and it is a classical result of Masur and Veech that the suborbifold formed by area 1 translation surfaces always has finite volume.

Consider now a tuple of integers $\kappa_i \geq -1$ and denote by $\mathcal{Q}(\kappa_1, \kappa_2, \dots, \kappa_m)$ the space of meromorphic quadratic differentials (X, q) (up to isomorphism) for which X is homeomorphic to a genus g compact surface and all poles of q are simple. This set is also called a stratum. In this case (X, q) has a conical singularity of angle $(2 + \kappa_i)\pi$ at each p_i (and are flat elsewhere).

The genus of these surfaces is given by $\sum_{i=1}^m \kappa_i = 4g - 4$. Period coordinates and a finite measure can also be defined for $\mathcal{Q}(\kappa_1, \kappa_2, \dots, \kappa_m)$ by considering orientation double coverings.

The orientation double covering of a meromorphic differential (X, q) in $\mathcal{Q}(\kappa_1, \kappa_2, \dots, \kappa_m)$ is a translation surface with conical singularities of angles $2(1 + \kappa'_{i_1})\pi, 2(1 + \kappa'_{i_2})\pi, \dots, 2(1 + \kappa'_{i_l})\pi$ where the computation of the values $(\kappa'_{i_j})_{j=1}^l$ are left to the reader (see exercise 1.1.19). Given that there is no canonical way to enumerate the conical singularities appearing in the orientation double cover, there is no canonical way to associate to this cover a point in a strata of translation surfaces. However one can overcome this technical nuisance by considering a finite covering⁵ $\mathcal{Q}^{or}(\kappa_1, \kappa_2, \dots, \kappa_m) \rightarrow \mathcal{Q}(\kappa_1, \kappa_2, \dots, \kappa_m)$, on which a well-defined map into a strata of translation surfaces can be defined. It is customary to compose this map with a forgetful map to get rid off the marked points. The composition of the aforementioned maps is an immersion (see Lemma 1, Section 2.1 in [?]).

Exercise 1.1.32

Show that the example from Figure 1.3 belongs to $\mathcal{Q}(2, -1, -1)$ and hence, its orientation cover belongs to $\mathcal{H}(1, 1)$ (when forgetting the marked points). Determine the order of the covering of $\mathcal{Q}(2, -1, -1)$ that can be immersed into $\mathcal{H}(1, 1)$.

Remark 1.1.33. Following tradition, the stratum of translation surfaces with n conical singularities of the same angle, say $2(1 + \kappa)\pi$, is abbreviated by $\mathcal{H}(\dots, \kappa^n, \dots)$. The same applies to strata of quadratic differentials. For example $\mathcal{H}(1^2) = \mathcal{H}(1, 1)$ while $\mathcal{Q}(2, -1^2) = \mathcal{Q}(2, -1, -1)$.

Remark 1.1.34. For infinite-type surfaces, there are many sorts of wild singularities. They are discussed in detail in Section 2.3. One could classify wild singularities according to their local geometry and in this way extend the definition of strata for infinite-type surfaces. The remaining (big) difficulty is to find convenient analogs of period coordinates and the Masur-Veech measure.

1.2 Examples

In the rest of this chapter we present a list of examples of infinite-type translation surfaces. These are revisited later on to illustrate general aspects of the objects defined in the preceding section.

1.2.1 Polygonal billiards

Polygonal billiards are a recurrent example in this text. Roughly speaking, a polygonal billiard is the dynamical system defined by the frictionless motion of a point-particle inside an Euclidean polygon P where all collisions with the boundary are elastic. This means that each time that a point hits a side of the polygon the angle of incidence of its trajectory will be equal to the angle of reflection. By convention, the motion of a point ends when reaching a corner. One of the main motivations to study polygonal billiards is the following old conjecture:

Question 1.2.1

Every polygonal billiard has a closed trajectory.

A trajectory is closed if the point that follows it returns (after finitely many bounces) to its starting position *with the same direction* on which it started its motion. According to R. E. Schwartz “it is fair to say that this 200-year-old problem is widely regarded as impenetrable” [Sch09]. The conjecture is true for acute and right triangles, every rational triangle [Mas86] and all obtuse triangles whose big angle is at most $5/9\pi$ [Sch09]. Despite all these evidence, one has to be prudent: for any $\varepsilon > 0$ there exists a triangle whose two small angles are within ε radians of $\frac{\pi}{6}$ and $\frac{\pi}{3}$ respectively that has no periodic billiard path of combinatorial length⁶ less than $\frac{1}{\varepsilon}$ [Sch06]. We refer the reader to [Sch09] and references therein for more details on this conjecture.

A common trick to study billiards in polygons is to produce from P a translation surface $M(P)$ using an unfolding process. We follow the approach of J.C. Yoccoz to explain this process, see [Yoc10],

⁵Formally speaking one has to consider covering in the class of orbifolds.

⁶The *combinatorial length* of a periodic billiard path is defined as the number of times the point bounces on the boundary of the polygon before returning to its initial position *with the same direction* it started its motion.

though this trick appears in different guises in the literature, as early as 1936 in a paper by Fox and Kershner [FK36] and in a 1975 paper by Katok and Zemlyakov [KZ75].

Let $\{e_1, e_2, \dots, e_n\}$ be the sides of P , $r(e_j)$ be the linear part of the element in $\text{Isom}(\mathbb{R}^2)$ given by the reflection with respect to the line containing e_j for $j \in \{1, 2, \dots, n\}$ and $R < \text{O}(2, \mathbb{R})$ be the subgroup generated by $\{r(e_1), \dots, r(e_n)\}$. We define a topological space $M(P)$ as the quotient of $P \times R$ by the following equivalence relation. Two points (z, r) and (z, r') are equivalent if and only if $z = z'$ and:

1. $r^{-1}r' = \mathbf{1}_R$ if z belongs to the interior of P ,
2. $r^{-1}r' \in \{\mathbf{1}_R, r(e_j)\}$ if z belongs to the side e_j ,
3. $r^{-1}r' \in R_z$ if z is a vertex of P , where R_z is the subgroup of R generated by $r(e_i)$ and $r(e_j)$ if z is the vertex given by the intersection of the sides e_i and e_j .

We denote by Σ the image in $M(P)$ of the vertices of P . It is always possible to define a translation surface structure on $M(P) \setminus \Sigma$. Indeed, if we denote by $\overset{\circ}{P}$ the interior of P then:

- for each $r \in R$ the map $\overset{\circ}{P} \times \{r\} \rightarrow \mathbb{R}^2$ given by $(z, r) \rightarrow r(z)$ defines a chart and
- if z belongs to the side e_j (but is not a vertex) of P and $r \in R$, let $U = B(z, \varepsilon) \cap P$ with $\varepsilon > 0$ small enough so that U is an open half-disc plus its diameter. The map:

$$U \times \{r, rr(e_j)\} \rightarrow \mathbb{R}^2$$

sending (z, r) to $r(z)$ and $(z, rr(e_j))$ to $f_{r(e_j)}(r(z))$, where $f_{r(e_j)}$ is the reflection with respect to line containing the image of the side $e_j \times \{r\} \subset P \times \{r\}$ in the plane, defines a chart around z .

Exercise 1.2.2

Let P be an Euclidean polygon.

1. Show that the charts defined above define a translation surface structure on $M(P) \setminus \Sigma$.
2. Suppose that all interior angles of P are commensurable with π and let N be the smallest integer such that any interior angle of P can be written as $\pi \frac{m}{N}$ for some $m \in \mathbb{N}$. Show that in this case R is isomorphic to the dihedral group of order $2N$:

$$\langle a, b \mid a^2 = 1, b^N = 1, (ab)^2 = 1 \rangle.$$

3. Let $z \in P$ be a vertex defined by the intersection of the sides e_i and e_j and let as before R_z be the subgroup of R generated by $r(e_i)$ and $r(e_j)$. Prove that:
 - (a) If the interior angle of P at z is of the form $\pi \frac{p}{q}$ with $p, q \in \mathbb{N}$ relatively prime, then R_z is isomorphic to the dihedral group of order $2q$. Deduce that if we add the image of the vertex z to $M(P) \setminus \Sigma$ we obtain a cone angle singularity of total angle $2p\pi$.
 - (b) If the interior angle of P at z is of the form $\lambda\pi$, with $\lambda \in \mathbb{R} \setminus \mathbb{Q}$, then R_z (and hence R) is infinite. Deduce that if we add the image of the vertex z to $M(P) \setminus \Sigma$ we obtain an infinite cone angle singularity.

From the preceding exercise we deduce that Euclidean polygons can be classified into those for which every interior angle is commensurable with π and those for which this is not the case. The former are called *rational polygons* and the later *irrational polygons*.

Billiard trajectories and translation flows. The main point of introducing the unfolding trick is to relate billiard trajectories on P to trajectories of the translation flow on $M(P) \setminus \Sigma$. Let $\gamma(t)$, $t \in [0, T]$ be a billiard trajectory which bounces on the sides of P at times $0 < t_1 < \dots < t_N < T$. Denote by e_{t_i} the side that $\gamma(t)$ encounters at $t = t_i$. Define $r_{t_0} := \mathbf{1}_R$ and $r_{t_{i+1}} := r_{t_i} r(e_{t_{i+1}})$. Then for every $r \in R$ the image on $M(P) \setminus \Sigma$ of the path defined by the formulas:

$$\gamma_r(t) = \begin{cases} (\gamma(t), rr_{t_0}) & \text{for } 0 \leq t \leq t_1 \\ (\gamma(t), rr_{t_i}) & \text{for } t_i \leq t \leq t_{i+1}, i < N \\ (\gamma(t), rr_{t_N}) & \text{for } t_N \leq t \leq T \end{cases}$$

defines a trajectory of the translation flow on $M(P) \setminus \Sigma$. Conversely, the image of every piece of trajectory of the translation flow on $M(P) \setminus \Sigma$ by the natural projection $\pi_P : M(P) \rightarrow P$ defines a billiard trajectory on P . Hence, we can reformulate many problems of billiards dynamics in terms of translation flows in $M(P) \setminus \Sigma$. In figure 1.6 we depict the unfolding process and the relation between billiard trajectories and the translation flow for the case of the billiard in the unit square.

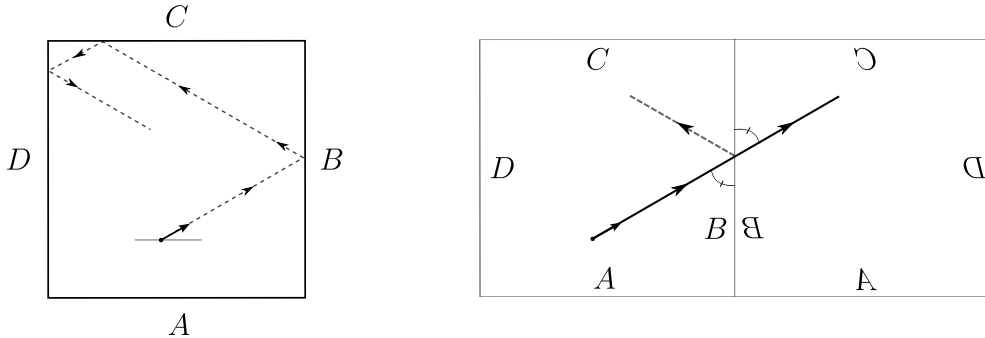

Figure 1.6: Billiard inside the unit square and the unfolding of a billiard trajectory.

The topology of $M(P)$. If P is a rational polygon, exercise 1.2.2 above implies that $M(P)$ is a compact translation surface tiled by finitely many copies of the polygon P . In figure 1.7 we depict $M(P)$ for a triangle P with interior angles $(\frac{\pi}{2}, \frac{\pi}{8}, \frac{3\pi}{8})$. Remark that $M(P)$ in this case is obtained by identifying opposite sides using translations on a regular octagon. By making a straightforward calculation on the number of copies of P tiling $M(P)$ and applying the formula that relates the Euler characteristic of $M(P)$ to its genus, we deduce that this translation surface has genus 2 and only one conic singularity of total angle 6π . In the same figure we illustrate how a billiard trajectory on P unfolds in $M(P)$. In general, if P has interior angles $\frac{p_i}{q_i}\pi$, a direct application of the Euler characteristic formula shows that

$$\text{genus}(M(P)) = 1 + \frac{N}{2} \left(n - 2 - \sum_{i=1}^n \frac{1}{q_i} \right) \tag{1.7}$$

where $N = \text{lcm}(q_1, \dots, q_n)$. For a detailed proof of this formula see [Tab05, Theorem 7.22]. In particular, the topology $M(P)$ when P is a rational polygon depends on the interior angles of P .

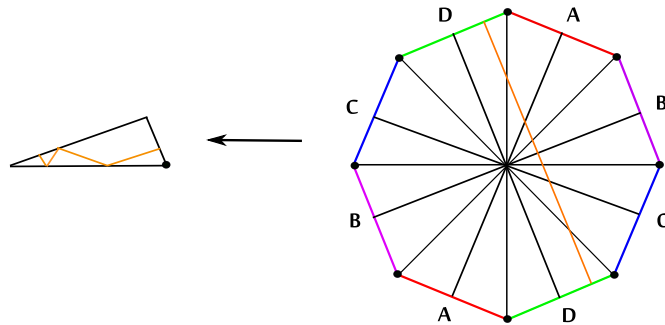

Figure 1.7: The billiard in the triangle P with interior angles $(\frac{\pi}{2}, \frac{\pi}{8}, \frac{3\pi}{8})$ and the associated surface $M(P)$.

If P is an irrational polygon, exercise 1.2.2 above implies that $M(P)$ is not a manifold on points $p \in \Sigma$ coming from vertices where the interior angle is not commensurable with π . Indeed, since any such point p is an infinite angle singularity, no neighbourhood of p is compact and hence there cannot be a chart around this point into the plane. To avoid this nuisance we *remove first* from P all vertices on which interior angles are not commensurable with π and then we perform the unfolding construction. The result is a translation surface that we henceforth, abusing notation, denote by $M(P)$. Remark that in this case the group $R \cap \text{SO}(2, \mathbb{R})$ has index 2 in R and is of the form $\mathbb{Z}^{\rho(P)} \times G$ where G is finite and the non-negative integer $\rho(P)$ is called the *rank* of P . The following theorem, whose proof will be discussed in Example 2.2.9 of Section 2.2 describes the topology of this surface.

Theorem 1.2.3: [Val09b]

Let P be an euclidean polygon with interior angles $\lambda_j\pi$, $j = 1, \dots, N$. If there exists $\lambda_j \in \mathbb{R} \setminus \mathbb{Q}$, then $M(P)$ is homomorphic to an infinite genus surface with one end.

In other words, *all* translation surfaces stemming from irrational polygons are homeomorphic and of infinite type.

It is fair to say that one can play billiards in domains of \mathbb{R}^2 which are more complicated than an Euclidean polygon. To fix ideas let us introduce a more general notion of polygon.

Definition 1.2.4. A *generalized polygon* is a closed subset P of \mathbb{R}^2 whose boundary is a union of (Euclidean) segments such that for any compact set $K \subset \mathbb{R}^2$ the intersection $K \cap \partial P$ is a finite union of segments. The segments forming ∂P are called the *sides* of the generalized polygon.

All Euclidean polygons as well as the complement of their interior are generalized polygons. Two examples of generalized polygons are depicted in Figure 1.8.

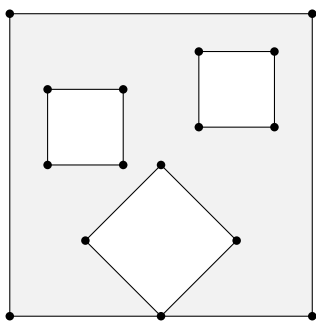

(a) A rational generalized polygon.

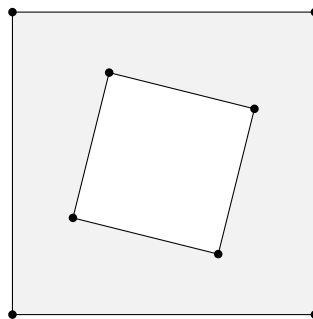

(b) An irrational generalized polygon as considered in Exercise 1.2.6.

Figure 1.8: Two bounded generalized polygons.

Definition 1.2.5. Let P be a generalized polygon with sides $\{e_1, e_2, \dots\}$ and $R < O(2, \mathbb{R})$ be the group generated by the linear parts of the reflections w.r.t. the lines containing e_j for each $j \in \{1, 2, \dots\}$. Then P is called a *rational* generalized polygon if the group R is finite and *irrational* otherwise.

Exercise 1.2.6

The purpose of this exercise is to illustrate that there are rather simple generalized polygons whose interior angles are all commensurable with π but for which the unfolding process leads to an infinite type translation surface. Consider two concentric and disjoint squares $P_1 \subset P_2$ such that P_1 is obtained from P_2 by a homothety followed by a rotation by an angle $\lambda\pi$ with $\lambda \in \mathbb{R} \setminus \mathbb{Q}$ (see Figure 1.8b). Let P be the closure in the plane of $P_2 \setminus P_1$. Prove that if we apply the unfolding process described in the preceding paragraph we obtain an infinite area infinite genus translation surface $M(P)$. Describe the set of conic singularities.

By definition, a compact generalized polygon P is rational if and only if the translation surface $M(P)$ obtained by the unfolding process is compact (and hence of finite type). Exercise 1.2.6 shows that there are *irrational* compact generalized polygons whose interior angles are commensurable to π . As we will see later, the so-called wind-tree models are special classes of non-compact rational generalized polygons such that $M(P)$ is of infinite topological type and whose billiard dynamic is quite interesting.

Remark 1.2.7. There are even more general spaces on which one can consider billiard dynamics and the unfolding trick. For example the so-called *parking garages* introduced by M. Cohen and B. Weiss, see [CW12].

1.2.2 Baker's surfaces.

In this section we construct, for each $\alpha \in (0,1)$ a finite-area translation surface of infinite genus B_α . These examples are called *baker's surfaces* for, as explained in [CGL06], they appear when considering the classical *baker self-map* on the unit square. They are also examples of Thurston-Veech surfaces that will be discussed in Sections 1.2.6 and 3.5.

Understanding the construction of baker's surfaces is easier when considering Figure 1.9. Let $abcd$ be a square, where ab and bc are the upper and right sides respectively, and suppose that these sides have length $\frac{\alpha}{1-\alpha}$. For each $i \in \mathbb{N}$, define $a_i \in ab$ and $b_i \in bc$ to be the point such that $|a_i b| = |b_i b| = \frac{\alpha^i}{1-\alpha}$. Analogously, let $c_i \in cd$ and $d_i \in da$ be such that $|c_i d| = |d_i d| = \frac{\alpha^i}{1-\alpha}$. Let us also denote $a_0 = c_0 = a$ and $b_0 = d_0 = c$. These points define a partition of the sides and each segment $[a_i, a_{i+1}]$, $[b_i, b_{i+1}]$, $[c_i, c_{i+1}]$ and $[d_i, d_{i+1}]$ have length α^i (see Figure 1.9). Identify using a translation the horizontal sides $[a_i, a_{i+1}]$ with $[c_i, c_{i+1}]$ (identified with the label A_i on Figure 1.9) and the vertical sides $[b_i, b_{i+1}]$ with $[d_i, d_{i+1}]$ (identified with the label B_i on Figure 1.9). We denote by \widehat{B}_α the topological space that results from these identifications. This notation is justified by the following exercise.

Exercise 1.2.8

Show that if we remove from \widehat{B}_α the image of the points $\{a_i, b_i, c_i, d_i\}_{i=0}^\infty$, the result is a geometric translation surface, that is, it has a natural atlas whose change of coordinates area translations. We denote this surface by B_α . Show that for each $\alpha \in (0,1)$ the metric completion of B_α w.r.t. the flat metric is obtained by adding just one point x_∞ . Moreover, show that this point is a wild singularity and that the metric completion of B_α is precisely the quotient \widehat{B}_α defined above.

All surfaces B_α are homeomorphic to each other and by construction every B_α is a translation surface formed only by flat points, *i.e.* it contains no conical singularities. However, as the preceding exercise shows, a wild singularity appears when considering its metric completion, see Definition 1.1.22. We will discuss wild singularities with more detail in the next chapter. On the other hand, as we will see in Section 3.6, for $\alpha = \frac{1}{q}$, $q \geq 2$, baker's surfaces have a lot of affine symmetries. More precisely, we will prove that the Veech group of $B_{\frac{1}{q}}$, for $q \geq 2$, is of the second kind and generated by two transverse parabolic automorphisms.

Remark 1.2.9. Baker's surfaces were originally introduced by R. Chamanara in [Cha04], though the recipe for its construction is attributed to A. de Carvalho. By this reason some authors call these surfaces *Chamanara's surfaces*. It is important to remark that R. Chamanara constructed his surfaces in [Cha04] from a unit square, *ergo* if we apply the homothety of factor $\frac{1-\alpha}{\alpha}$ to the square $abcd$ introduced above and proceed with the construction of B_α we retrieve Chamanara's original construction.

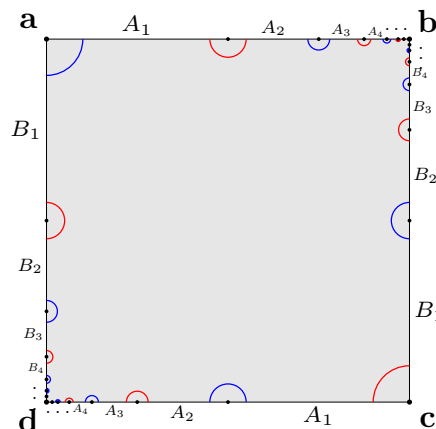

Figure 1.9: Baker's surface B_α for $\alpha = \frac{1}{2}$ and its wild singularity.

Question 1.2.10

In which directions θ does the surface B_α have a cylinder? In which directions θ does the translation flow F_θ^t have a dense trajectory?

We will see that in the case of $B_{1/2}$ the Hooper-Thurston-Veech machinery produces countably many directions θ with cylinders and uncountably many directions θ with dense trajectories. However, this is far from being a complete answer for $B_{1/2}$. Nothing is known for parameters α that are not rational numbers.

1.2.3 The infinite staircase

Infinite-type translation surfaces appear when considering infinite coverings of finite-type translation surfaces. This is a framework that we explore with more detail in Section 2.2 and we exploit recurrently along this text. The infinite staircase, introduced in section 1.1, was the first example of an infinite covering to be studied systematically, see [HHW13]. To be more precise, the infinite staircase is a covering (ramified over one point) of the flat torus obtained from the unit square. Translation surfaces which are coverings of flat torii ramified at most over one point are called *origamis* or *square-tiles surfaces*. The infinite staircase is thus an infinite-type origami and, as it can be seen from figure 1.2, it has four infinite angle singularities.

The infinite staircase has a lot of symmetries. Indeed, its affine group contains:

1. a group of translations isomorphic to \mathbb{Z} ,
2. two elements⁷ ψ_h and ψ_v with derivatives $D\psi_h = \begin{pmatrix} 1 & 2 \\ 0 & 1 \end{pmatrix}$ and $D\psi_v = \begin{pmatrix} 1 & 0 \\ 2 & 1 \end{pmatrix}$ and
3. a symmetry with derivative $-\mathbf{Id}$ that stabilizes the staircase at level 0, see figure 1.10 (a).

Theorem 1.2.11

The infinite staircase has the following geometric and dynamical properties:

- its affine group is generated by the elements enlisted above. In particular its Veech group is a lattice in $\mathrm{SL}(2, \mathbb{R})$ generated by the matrices $\begin{pmatrix} 1 & 2 \\ 0 & 1 \end{pmatrix}$ and $\begin{pmatrix} 0 & 1 \\ -1 & 0 \end{pmatrix}$,
- if $\theta \in \mathbb{R}/2\pi\mathbb{Z}$ is a direction of rational slope, then the translation flow F_θ^t decomposes the infinite staircase into infinitely many cylinders or into two infinite strips, and
- if $\theta \in \mathbb{R}/2\pi\mathbb{Z}$ is a direction of irrational slope, then the area measure is conservative^a and ergodic^b under the translation flow F_θ^t for the Lebesgue measure.

^a The measure is conservative if orbits of the system are recurrent. See Appendix A for a formal definition.

^b The measure is said to be ergodic if it is not possible to split the space into two invariant sets of positive measure. See Appendix A for a formal definition.

The ergodicity in irrational directions is due to J.-P. Conze [Con76], [CK76] and K. Schmidt [Sch78]. It was generalized later by I. Oren [Ore83] and strengthened into a measure classification by J. Aaronson, H. Nakada, O. Sarig and R. Solomyak [ANSS02]. The Veech group computation has been done by P. Hooper, P. Hubert and B. Weiss [HHW13] and the presence of these affine symmetries provides an alternative way to prove ergodicity of the translation flow. All this will be discussed in Chapter 6. Some more results about this model include [Kes60], [Ral14b], [ADDS15].

1.2.4 Wind-tree models

In this section we present a special kind of billiards on generalized polygons: wind-tree models. Historically, it was Paul and Tatiana Ehrenfest [EE12] who defined first the (random) wind-tree model as a simplified model of Lorenz gas. They were interested in the robustness of Boltzman's ergodic hypothesis. In this first version, square scatterers with random sizes are randomly placed in the plane, and the

⁷As we see later, these elements correspond to horizontal and vertical multitwists.

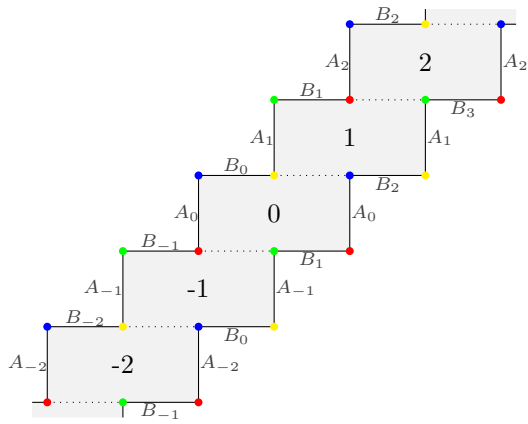

(a) The infinite staircase. A (ramified) covering of a torus with 4 singularities of infinite conical type.

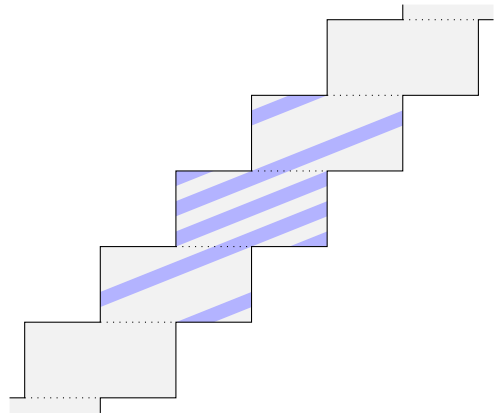

(b) In direction (p, q) with $p + q \equiv 1 \pmod 2$, the staircase decomposes into a countable union of cylinders. Here is the example $(p, q) = (5, 2)$.

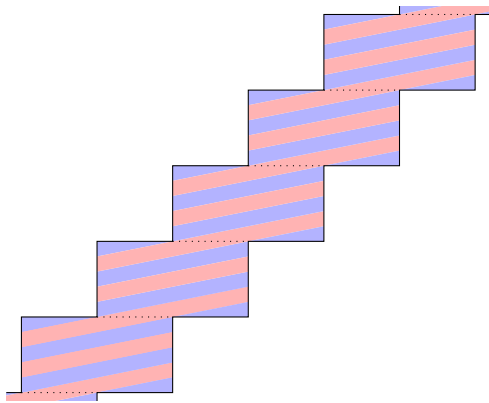

(c) In direction (p, q) with $p + q \equiv 0 \pmod 2$ and relatively prime, the staircase decomposes into a union of two strips. Here is the example of $(p, q) = (5, 1)$.

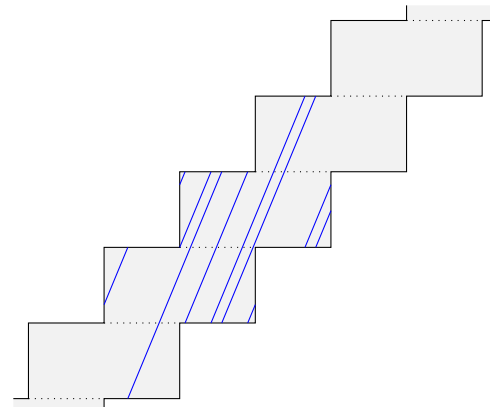

(d) A piece of a trajectory in the direction stabilized by the affine map $\psi_h \psi_v$.

Figure 1.10: The infinite staircase and some trajectories of its translation flows.

billiard ball could only move in a very specific direction (see Figure 1.11a). Much later on, two other physicists J. Hardy and J. Weber studied a periodic version of the Ehrenfests' wind-tree model [HW80] (see Figure 1.11b). However, they also considered the billiard flow only in some very specific directions. It was until the work of P. Hubert, S. Lelièvre and S. Troubetzkoy [HLT11] that the study of the billiard flow in a generic direction was initiated. Since then a lot of work has been devoted to the study of the periodic wind-tree models and their generalizations [AH], [DHL14], [Del13], [FU14b], [FU14a], [DZ], [Par]. Despite a huge amount of work in the periodic case, very little is known about the original Ehrenfests' wind-tree model. We discuss more on these random wind-tree models in Section 1.2.7. For the rest of this section we focus on Hardy-Weber's periodic wind-tree models.

Question 1.2.12

Describe the dynamics of the billiard ball on the original (random) Ehrenfests' wind-tree model for a generic direction $\theta \in \mathbb{R}/2\pi\mathbb{Z}$.

Periodic wind-tree models. Let \mathbb{Z}^2 be the standard lattice in \mathbb{R}^2 and $(a, b) \in (0, 1)^2$. For each $(m, n) \in \mathbb{Z}^2$ let us consider the rectangle $R_{m,n} = [m - a/2, m + a/2] \times [n - b/2, n + b/2]$ of size $a \times b$ centered at the lattice point (m, n) . We denote by $T_{a,b}$ the billiard table obtained by removing from the plane \mathbb{R}^2 the union of all rectangles $R_{m,n}$. We call the billiard table $T_{a,b}$ the *periodic wind-tree model* with parameters

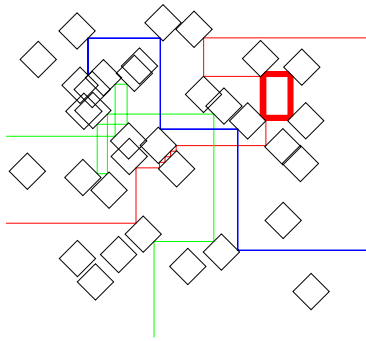

(a) The Ehrenfests' wind-tree model

(b) The Hardy-Weber periodic wind-tree model. In this picture the parameters are $a = b = 1/2$.

Figure 1.11: The original Ehrenfests' wind-tree model and the periodic version from Hardy-Weber.

(a, b). As discussed at the end of section 1.2.1, $T_{a,b}$ is a non-compact generalized polygon, and hence we can perform the unfolding trick on it.

Given that the billiard flow on the table $T_{a,b}$ is invariant under the action by translations of \mathbb{Z}^2 and the interior angles of $T_{a,b}$ are all equal to $\frac{3\pi}{2}$, when we perform the unfolding construction on $T_{a,b}$ the result is an infinite type surface $W_{a,b}$ which is a \mathbb{Z}^2 -covering of a genus 5 translation surface $\tilde{L}_{a,b}$ (see Figure 1.12b). It is easy to see that $W_{a,b}$ is a complete translation surface (for the flat metric) presenting only finite cone angle singularities. Note that the surface $\tilde{L}_{a,b}$ corresponds to the unfolding procedure applied to a billiard in a torus with a rectangular obstacle (see Figure 1.12a).

As we will see in chapter 2.2, it is possible to use standard arguments in covering space theory to prove that the infinite translation surface $W_{a,b}$ always has infinite genus and one end. Moreover, for infinitely many rational parameters (a, b) one can prove that the Veech group $\Gamma(W_{a,b})$ is infinitely generated (see Theorem 3.4.21 in Section 3.4).

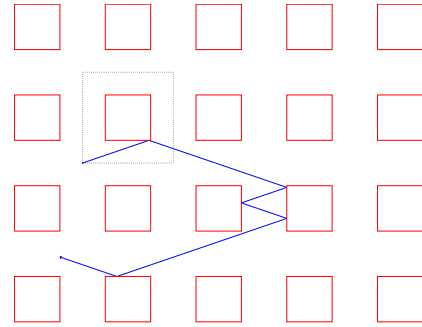
We summarise below what is known about the dynamics of the billiard flow on $T_{a,b}$ (or equivalently the translation flow on $W_{a,b}$). We refer the reader to Appendix A for a review of standard notions in dynamical systems such as recurrence or ergodicity in infinite-measure spaces.

Theorem 1.2.13: Generic and exceptional wind-tree behavior.

For every parameters $(a, b) \in (0, 1)^2$ the following is true for the translation flow F_θ^t on the translation surface $W_{a,b}$, obtained from the wind-tree model by unfolding, in a generic direction θ :

- the translation flow F_θ^t is conservative ^a,
- for all point $x \in W_{a,b}$ with infinite forward orbit we have

$$\limsup_{t \rightarrow \infty} \frac{\log d(x, F_\theta^t)}{\log t} = \frac{2}{3}.$$

where the distance is the distance in $W_{a,b}$,

- F_θ^t is not ergodic ^b.

However, for the parameters $a = b = 1/2$

- there are uncountably many angles θ for which the flow F_θ^t is completely dissipative ^c,
- there are uncountably many angles θ for which the flow F_θ^t is ergodic.

^a See footnote a of Theorem 1.2.11 for the definition.

^b See footnote b of Theorem 1.2.11 for the definition.

^c A system is dissipative if orbits are divergent. This is the opposite behavior of conservative from footnote a of Theorem 1.2.11. We refer to Appendix A for the formal definition.

The recurrence is due to A. Avila and P. Hubert [AH] and will be treated in Section 5.4. The rate diffusion is a manifestation of the *Kontsevich-Zorich phenomenon* and in this context, the result is due to V. Delecroix, P. Hubert and S. Lelièvre [DHL14] and is explained in Section 5.6. The non-ergodicity is a phenomenon found by K. Fraczek and C. Ulcigrai [FU14b] that we see in Section 6.1.1. The existence of divergent flow is due to V. Delecroix [Del13]. Finally, the existence of ergodic directions is a consequence

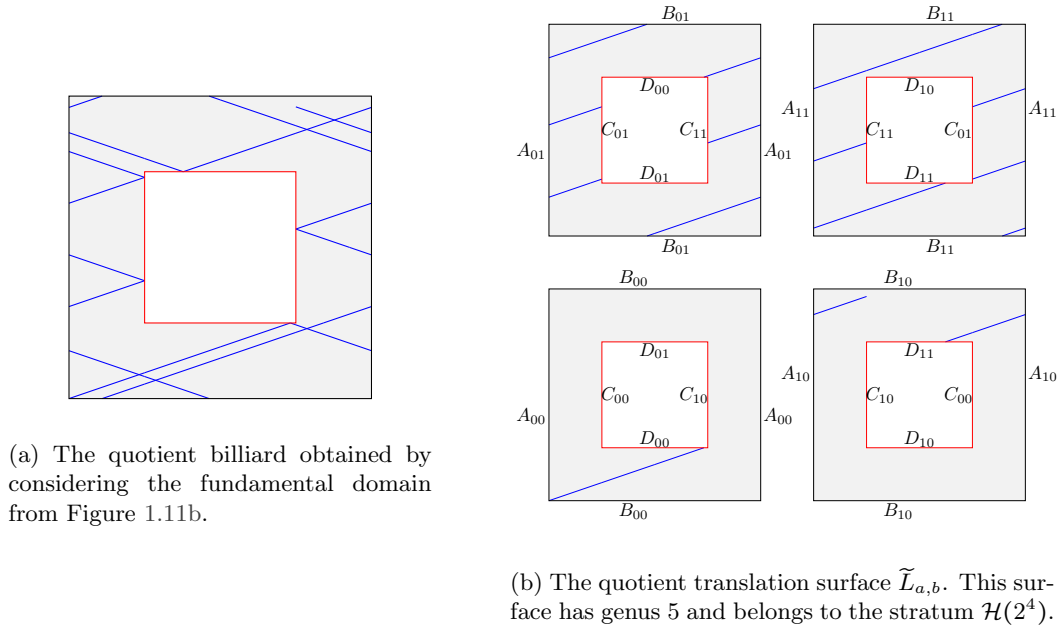

Figure 1.12: The billiard and compact translation surface obtained as the quotient of the periodic wind-tree model with parameters $a = b = 1/2$. The quotient of the orbit shown in Figure 1.11b is shown in blue in both figures.

of the work of P. Hooper [Hoo15] or a method relative to \mathbb{Z}^d -coverings. Both topics will be discussed in Section 6.1.2.

1.2.5 Panov planes

In [Pan09], D. Panov provided one of the first studies of the dynamics of the foliations in an infinite area quadratic differential. His construction was then revived recently in [JS14], [FS14], [Art] and [FSC].

Definition 1.2.14. A *Panov plane* is the universal cover of a non-zero meromorphic quadratic differential on a torus whose poles are all simple, if any. Equivalently, it is a non-zero meromorphic quadratic differential in the complex plane whose poles are all simple (if any) and that is invariant under translation by a lattice.

Here we discuss in detail the case of differentials in the stratum $\mathcal{Q}(2, -1^2)$ (that is quadratic differentials with one singularity of angle 4π and two singularities of angle π) which includes Panov original example. Let us first start with a simple surgery operation (see Figure 1.13).

Definition 1.2.15. Let M be a non-necessarily connected half-translation surface and γ_1 and γ_2 be two open oriented parallel geodesic segments in M with disjoint interiors which are disjoint from the singularities of M . The slit construction performed in M along (γ_1, γ_2) is the half-translation surface M' obtained by cutting M along γ_1 and γ_2 and gluing them back by gluing the left side of γ_1 to the right of γ_2 and vice-versa.

In this section we only consider slit constructions where γ_1 and γ_2 are the two oppositely-oriented halves of a given segment γ as in the right part of Figure 1.13. In this situation the two extremities of γ become a simple zero of the quadratic differential defining M' and the midpoint (corresponding to the junction of γ_1 and γ_2) becomes two simple poles⁸.

Now we arrive at the original Panov construction. Consider the quadratic differential (\mathbb{C}, dz^2) , let $\Lambda_0 = \mathbb{Z}(3, 0) \oplus \mathbb{Z}(0, 1)$ and $v_0 = (2, 0)$. We perform a slit construction along each segment $[t, t + v_0]$ for $t \in \Lambda$ and obtain the original Panov plane as drawn in Figure 1.14 (b). We denote by (\mathbb{C}, \tilde{q}) this quadratic differential. Since this construction is invariant under the translation by the lattice we obtain a differential (X, q) in genus one that belongs to the stratum $\mathcal{Q}(2, -1^2)$ (see Section 2.2 for more about coverings).

⁸Formally speaking these poles do not belong to M' but to the metric completion \widehat{M}' , see remark 1.1.16

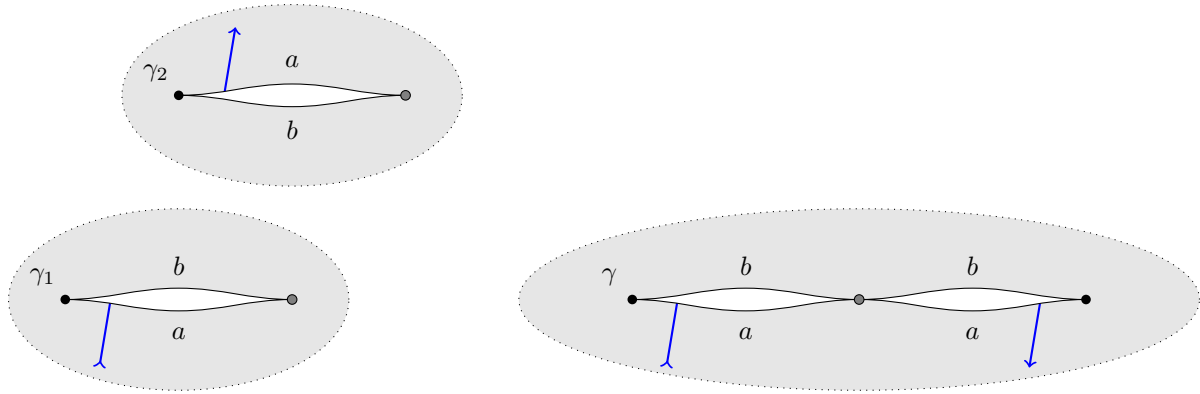
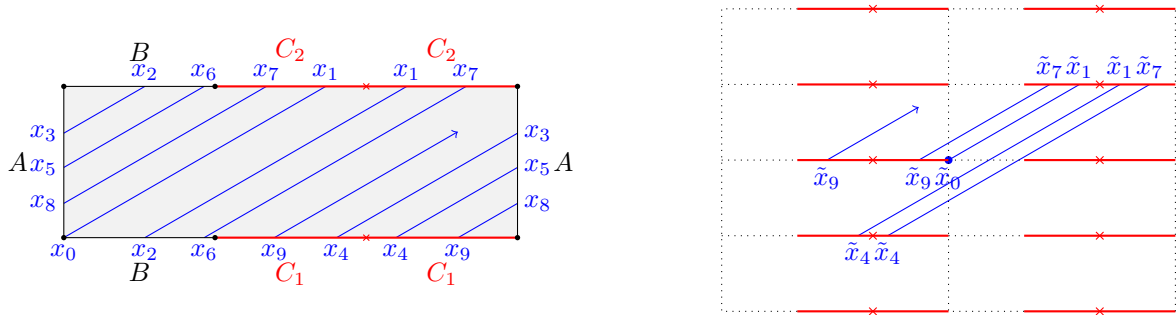

Figure 1.13: On the left, slit construction along γ_1 and γ_2 . A geodesic segment in the slit surface is drawn in blue. On the right, the special case where γ_1 and γ_2 are two oppositely oriented halves of a given segment γ .



(a) A flat picture of (X, q) in $\mathcal{Q}(2, -1^2)$.

(b) A flat picture of (\tilde{X}, \tilde{q}) .

Figure 1.14: The original example of D. Panov. The torus (on the left) is built from three unit squares with identifications given by the upper case letters. Its universal cover (on the right) can be seen as the flat plane with slits displaced periodically. A separatrix starting from x_0 and its lift starting from \tilde{x}_0 are show in blue. Each segment $[x_i, x_{i+1}]$ corresponds to a piece of the orbit. The lift of x_i is denoted by \tilde{x}_i .

Now let us consider an affine pseudo-Anosov element $\phi \in \text{Aff}(X, q)$ of the torus covered by the original Panov plane. It has an induced action ϕ_* on $H_1(X; \mathbb{Z}) \simeq \mathbb{Z}^2$. This action is tightly linked to the behavior of the lifting of the invariant foliations of ϕ to the plane.

The following exercise provides some computations of ϕ_* (see Figure 1.15 for an application).

Exercise 1.2.16

Let $(\mathbb{C}, \tilde{q}) \rightarrow (X, q)$ be the Panov plane of Figure 1.14.

1. Let a (respectively b) be a closed curve in (X, q) obtained by joining the left side denoted A to the right one (resp. the bottom side denoted B to the top one). Show that $H_1(X; \mathbb{Z}) = \mathbb{Z}a \oplus \mathbb{Z}b$.
2. Show that there exists two elements ϕ_h and ϕ_v in $\text{Aff}(X, q)$ so that ϕ_h acts as a horizontal twist, ϕ_v as a vertical twist and their derivatives are $D\phi_h = \begin{pmatrix} 1 & 3 \\ 0 & 1 \end{pmatrix}$ and $D\phi_v = \begin{pmatrix} 1 & 0 \\ 1 & 1 \end{pmatrix}$ (note: this is a special case of the Thurston-Veech construction of Section 1.2.6).
3. Let $\rho : \text{Aff}(X, q) \rightarrow \text{SL}(2, \mathbb{Z})$ be defined by $\rho(\phi) = \phi_*$ after having identified $H_1(X; \mathbb{Z})$ to \mathbb{Z}^2 using the basis (a, b) from the first question. Show that

$$\rho(\phi_h) = \begin{pmatrix} 1 & 1 \\ 0 & 1 \end{pmatrix} \quad \text{and} \quad \rho(\phi_v) = \begin{pmatrix} 1 & 0 \\ 1 & 1 \end{pmatrix}.$$

4. Show that $\rho(\phi_h \phi_v^{-1} \phi_h)$ is elliptic of order 6.

5. Show that $\rho(\phi_h\phi_v)$ is hyperbolic.
6. Show that $\rho(\phi_h\phi_v^{-2}\phi_h)$ is parabolic.

Theorem 1.2.17: Kontsevich-Zorich phenomenon for pseudo-Anosov homeomorphisms

Let $(\mathbb{C}, \tilde{q}) \rightarrow (X, q)$ be a Panov plane. Let $\phi : X \rightarrow X$ be an affine pseudo-Anosov homeomorphism of (X, q) and let $\phi_* : H_1(X; \mathbb{Z}) \rightarrow H_1(X; \mathbb{Z})$ be its induced action on homology. Then

1. if ϕ_* is the identity or elliptic, then the eigenfoliations of ϕ in (X, q) lift to ergodic foliations of \mathbb{C} .
2. If ϕ_* is hyperbolic, there exist directions v^+ (respectively v^-) in $\mathbb{R}^2 \setminus \{0\}$ so that each lift $\tilde{\gamma}$ of a leaf of the unstable (resp. stable) eigenfoliation of ϕ is at bounded distance from $\mathbb{R}v^+$ (resp. $\mathbb{R}v^-$).

Concrete examples of each case of the above result are provided in Figure 1.15. The relevant computations were proposed in Exercise 1.2.16. This result is actually another manifestation of the so called Kontsevich-Zorich phenomenon (see Section 5.6).

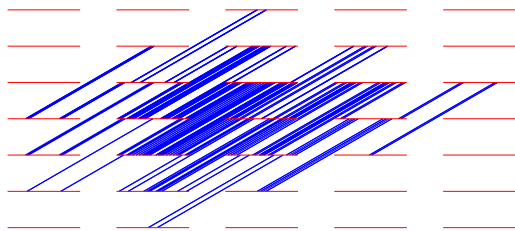

(a) Elliptic case (original Panov example, $\phi_h\phi_v^{-1}\phi_h$) in direction $(\sqrt{3}, 1)$.

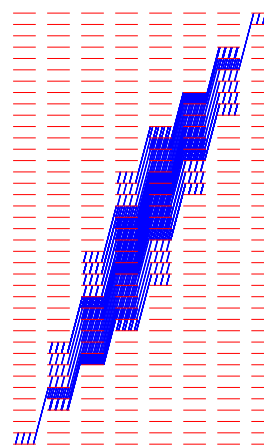

(b) Hyperbolic case ($\phi_h\phi_v$) in direction $(6, -3 + \sqrt{21})$.

Figure 1.15: Kontsevich-Zorich phenomenon for lifting of invariant foliations of pseudo-Anosov homeomorphisms in Panov planes.

We now study a natural generalization of Panov's example. Let $\Lambda \subset \mathbb{C}$ be a lattice and $v \in \mathbb{C}^*$ so that the open segment $\{tv : t \in (0, 1)\}$ is disjoint from Λ . We define the quadratic differential $\tilde{q}_{\Lambda, v}$ in the plane by adding a slit parallel to v based at each point of Λ . Because this construction is invariant under the action of Λ by translation we can also make this slit construction in the torus \mathbb{C}/Λ and obtain a quadratic differential $q_{\Lambda, v}$. This is illustrated in Figure 1.16.

Exercise 1.2.18

1. Show that any differential in $\mathcal{Q}(2, -1^2)$ is hyperelliptic^a and that the quotient by the hyperelliptic involution is a quadratic differential in $\mathcal{Q}(0, -1^4)$.
2. Show that this quotient operation provides an isomorphism^b $\mathcal{Q}(2, -1^2) \simeq \mathcal{Q}(0, -1^4)$.
3. By considering a different cover of $\mathcal{Q}(0, -1^4)$, show that there exists an isomorphism between $\mathcal{Q}(0, -1^4)$ and $\mathcal{H}(0, 0)$.
4. Express the isomorphisms of questions 2 and 3 in terms of the lattices Λ and non-zero vectors $v \in \mathbb{C}^*$ that we used to build the differential $q_{\Lambda, v}$ in $\mathcal{Q}(2, -1^2)$.

^aRecall that a quadratic differential (X, q) is hyperelliptic if it is a double covering of a quadratic differential on the sphere $(\mathbb{C}P^1, \tilde{q})$. That is to say, there exists an involution of the surface M that preserves the quadratic differential and such that the quotient is (topologically) a sphere.

^bYou can first try to prove that this operation is an $SL_2(\mathbb{R})$ -equivariant bijection. If you know about period coordinates and the linear structure of strata you can prove that it is an isomorphism of linear varieties. To learn about period coordinates see [Zor06] Chapter 3 "Families of Flat Surfaces and Moduli Spaces of Abelian Differentials,

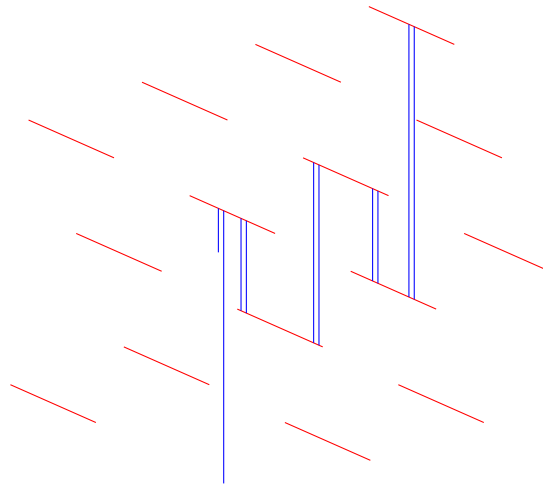

Figure 1.16: A Panov plane coming from a quadratic differential in $\mathcal{Q}(2, -1^2)$.

[FM14] Section 2.3 “Period map and local coordinates” or [Yoc10] Section 6 “The Teichmüller space and the Moduli Space”.

The space $\mathcal{Q}(2, -1^2)$ (or equivalently $\mathcal{H}(0, 0)$, see Exercise 1.2.18) plays a distinguished role. First of all because of its relation to 2-dimensional affine lattices⁹. Another reason that motivates its study is a model that shares some analogy with the periodic wind-tree model. A *circular Eaton lens* is a physical gadget that has the following property: every light ray that enters the lens is reflected in the same direction but with opposite orientation (see Figure 1.17b). More precisely the Eaton Lens of radius R is a ball of radius R such that a trajectory entering at $Re^{i\alpha}$ in direction $e^{i\theta}$ will exit from $Re^{i(2\theta-\alpha)}$ with direction $e^{-i\theta}$ (see Figure 1.17a). The precise behavior of the trajectory inside the ball is not important for our purposes. Periodic configurations of Eaton lenses are discussed in the following exercise.

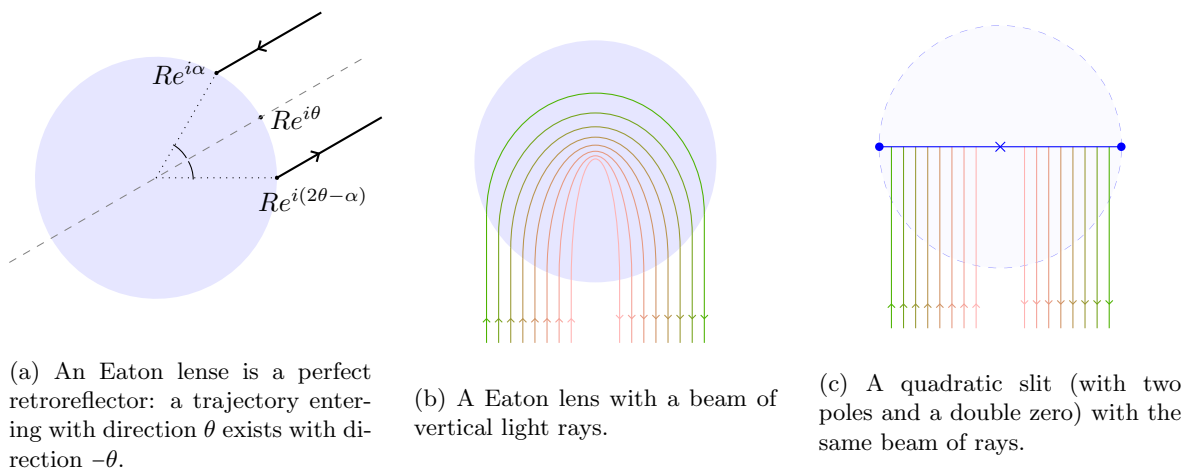

Figure 1.17: From an Eaton lens to its flat model.

Exercise 1.2.19

Let $\Lambda \subset \mathbb{C}$ be a lattice and $R > 0$ so that $R < \min_{u, v \in \Lambda, u \neq v} \|u - v\|$. Let $E_{\Lambda, R}$ be the plane \mathbb{C} on which an Eaton lens of radius R is disposed at each point of Λ (the condition on R ensures that the lenses do

⁹The moduli space of 2-dimensional lattices $SL(2, \mathbb{R})/SL(2, \mathbb{Z})$ is naturally identified to the moduli space of volume one flat tori $\mathcal{H}_1(0)$. The moduli space of affine lattices $SL(2, \mathbb{R}) \times \mathbb{R}^2 / (SL(2, \mathbb{Z}) \times \mathbb{Z}^2)$ can be identified to the union $\mathcal{H}_1(0, 0) \sqcup \mathcal{H}_1(0)$ where $\mathcal{H}_1(0, 0)$ corresponds to affine lattices $\Lambda + v$ so that $v \notin \Lambda$. This identification is $SL(2, \mathbb{R})$ -equivariant and allows to see $\mathcal{H}_1(0, 0)$ as a dense $SL(2, \mathbb{R})$ -invariant set in the space of affine lattices.

not intersect). We have a well defined non-orientable foliation in $E_{\Lambda,R}$ for each direction θ .

1. Show that the vertical flow in $E_{\Lambda,R}$ can be identified with vertical flow in a Panov plane \tilde{q}_{Λ,v_0} for a unique $v_0 \in \mathbb{C}$ outside of the lenses (in other words each Eaton lens can be replaced by a slit as depicted in Figure 1.17).
2. Show that by applying a rotation one can naturally identify the foliation in direction θ of $E_{\Lambda,R}$ to the vertical foliation of $e^{-i\theta}E_{\Lambda,R}$.
3. Deduce that the one-parameter family of differentials in $\mathcal{Q}(2, -1^2)$ obtained by rotating the direction in $E_{\Lambda,R}$ is different from the family $\{e^{i\theta}q_{\Lambda,v_0}\}$.

Theorem 1.2.20: generic behavior for $\mathcal{Q}(2, -1^2)$

Let $q_{\Lambda,v}$ be a quadratic differential in $\mathcal{Q}(2, -1^2)$. Then for almost every direction θ each leaf of the foliation in direction θ stays at bounded distance from a line.

The above result is another manifestation of the Kontsevich-Zorich phenomenon that, in this form, is due to K. Frączek and M. Schmoll [FS14]. A stronger form of this theorem has been recently proved by K. Frączek, R. Shi and C. Ulcigrai [FSC] (see Theorem 5.6.5 from Section 5.6.2).

As in the case of the wind-tree (see Theorem 1.2.13), there are some exceptional directions that contrast dramatically with the generic behavior of Theorem 1.2.20. Both phenomena discussed below are related to specific directions for which the associated Kontsevich-Zorich cocycle is the identity.

Theorem 1.2.21

Let $(\mathbb{C}, \tilde{q}) \rightarrow (X, q)$ be the Panov plane of Example 1.14. Then there are uncountably many directions in which the foliation is ergodic. This set of directions contains all eigendirections of pseudo-Anosov homeomorphisms in $\text{Aff}(X, q)$ so that their action on homology ϕ_* is elliptic.

The above result is quite similar to the last item in Theorem 1.2.13. It can be obtained from two very different sources. Either from general ergodic argument about G -coverings using essential values (see Theorem 6.1.4) or from the Hooper-Thurston-Veech construction for infinite-type surfaces discussed in Section 1.2.6.

Ergodicity implies that almost every trajectory is dense, but in general it is hard to provide a concrete example. This is precisely one of the main contributions of D. Panov [Pan09]: the construction of a dense leaf.

Theorem 1.2.22: [Pan09]

Let $(\mathbb{C}, \tilde{q}) \rightarrow (X, q)$ be the Panov plane of Example 1.14. Let ϕ be a pseudo-Anosov homeomorphism in $\text{Aff}(X, q)$ so that its action on homology ϕ_* is elliptic but not ± 1 . Then all separatrices in the eigendirection of ϕ are dense in (\mathbb{C}, \tilde{q}) .

This result applies in particular to the separatrix drawn in Figure 1.15a.

We now explain a relationship between the wind-tree model and Panov planes from $\mathcal{Q}(1^2, -1^2)$. Recall that the wind-tree model can be thought as a \mathbb{Z}^2 -periodic translation surface \widetilde{M} whose quotient M has genus 5. This surface M has many symmetries and in particular two quotients (X_h, q_h) and (X_v, q_v) that are quadratic differentials on tori. These surfaces are shown in Figure 1.18.

This point of view on the wind-tree model is the starting point of the article [DZ]. In this work the authors study generalizations of the wind-tree model with more complicated obstacles than rectangles but for which a quotient still exists in $\mathcal{Q}(1^{2n}, -1^{2n})$. Because of this, the diffusion rate of the translation flow can be computed in these more complicated surfaces.

1.2.6 Hooper-Thurston-Veech construction

On a widely circulated preprint Thurston explained how to construct affine pseudo-Anosov homeomorphisms on any finite-type surface. Given α and β two non-homotopic curves filling a topological surface S , there exists a unique half-translation q structure on S which admit two affine automorphisms ϕ_h and ϕ_v which respectively acts as a Dehn twist along α and β and have derivatives $D\phi_h = h_\lambda := \begin{pmatrix} 1 & \lambda \\ 0 & 1 \end{pmatrix}$ and

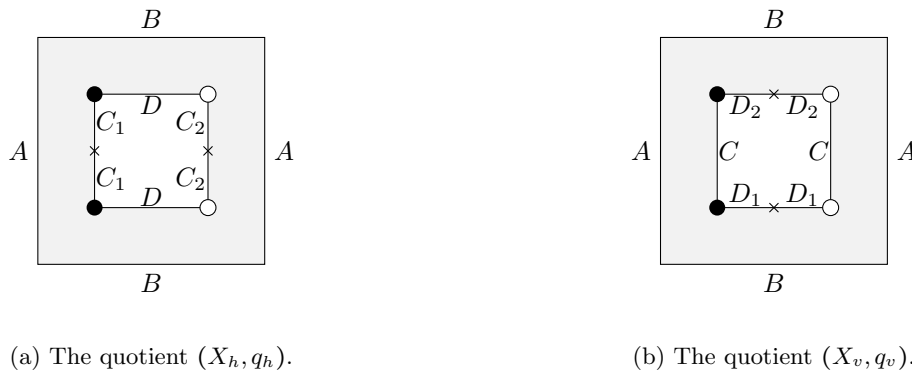

Figure 1.18: Two quotients of the surface S from Figure 1.12b obtained as the quotient of the wind-tree model. Both are hyperelliptic quadratic differentials that belong to $\mathcal{Q}(1^2, -1^2)$.

$D\phi_v := v_{-\lambda} = \begin{pmatrix} 1 & 0 \\ -\lambda & 1 \end{pmatrix}$, where $\lambda > 0$ is some real number. Because ϕ_h and ϕ_v are affine homeomorphisms of the same half-translation surface, they generate a subgroup of $\text{Aff}(S, q)$ most of its elements being pseudo-Anosov homeomorphisms. Thurston's construction was later extended by himself and Veech to the case of filling multicurves [Thu88], [Vee89]. In this section we first recall in detail Thurston-Veech construction. Then we illustrate with a family of examples arising from the infinite staircase how this construction can be extended for infinite-type surfaces. The details of this extension, that we call the Hooper-Thurston-Veech construction for it was developed by P. Hooper [Hoo15], are explained in full detail in Chapter 3.

Historical note. Thurston-Veech construction seems to be forgotten by the community during the 1990's until a Thursday evening in July 2003 when, after the traditional *Bouillabaisse*¹⁰ dinner at CIRM (France), John H. Hubbard revived the construction by explaining it to a large tipsy audience. For this reason, sometimes people refer to surfaces obtained by the Thurston-Veech construction as *Bouillabaisse surfaces*.

Thurston-Veech construction. Throughout this section we use the following notation for parabolic matrices in $\text{SL}_2(\mathbb{R})$

$$h_\lambda := \begin{pmatrix} 1 & \lambda \\ 0 & 1 \end{pmatrix} \quad \text{and} \quad v_\lambda := \begin{pmatrix} 1 & 0 \\ \lambda & 1 \end{pmatrix}. \quad (1.8)$$

Recall that the modulus of a cylinder¹¹ C is the real number $\mu(C) = \frac{\text{height}(C)}{\text{circumference}(C)}$. The basis of the Thurston-Veech construction is the following statement.

Lemma 1.2.23. *Let M be a finite-type translation or half-translation surface.*

If the horizontal foliation of M decomposes into r cylinders of commensurable moduli $\mu_i = \frac{n_i}{\lambda}$, then there exists a unique affine automorphism ϕ of M that stabilizes pointwise the boundaries of the cylinders and has derivative $D\phi = h_\lambda$.

Conversely, if ϕ is a parabolic affine homeomorphism of M with derivative h_λ then M decomposes into a finite family of maximal horizontal cylinders $\{H_1, \dots, H_r\}$ of commensurable moduli $\mu(H_i) = \frac{p_i}{q_i} \frac{1}{\lambda}$. Moreover, a finite positive power of ϕ stabilizes pointwise the boundary of each cylinder.

A parabolic automorphism that stabilizes the boundary of cylinders such as in Lemma 1.2.23 acts as a power of a Dehn twist in each cylinder. For this reason, such element is called a *multitwist*. The proof of the first part is left to the reader (the argument is contained in the first part of Exercise 1.2.25). The second part is a bit more delicate, a proof can be found in [?, Lemma 4, Section 1.4]¹².

Note that by applying rotations to M , a similar statement holds in any direction θ . In particular, if the vertical direction admits a cylinder decomposition with commensurable moduli, then the multitwist in the vertical direction has derivative

$$\begin{pmatrix} 0 & -1 \\ 1 & 0 \end{pmatrix} h_\lambda \begin{pmatrix} 0 & -1 \\ 1 & 0 \end{pmatrix}^{-1} = v_{-\lambda}.$$

¹⁰Bouillabaisse is a traditional Provençal fish stew originating from the port city of Marseille.

¹¹see Section 4.5.1 for the relevance of cylinder modulus as a conformal invariant.

¹²Be careful that in the reference [?] the authors used an opposite definition for modulus of a cylinder, namely $\text{circumference}(C)/\text{height}(C)$

Note that the derivative of a vertical multitwist has a negative sign!

In the following exercise, we invite the reader to make the converse of the Thurston-Veech construction. Namely start from a translation surfaces with transverse multitwists and analyze the coordinates of the translation surface in terms of the topology of the surface.

Exercise 1.2.24

Let M be a finite-type half-translation surface with conical singularities $\Sigma \subset \widehat{M}$ (recall that M is necessarily punctured at the simple poles, if any). Assume that M admits vertical and horizontal cylinder decompositions $H = \{H_1, \dots, H_r\}$ and $V = \{V_1, \dots, V_s\}$. Let $\gamma = \{\gamma_1, \dots, \gamma_r\}$ and $\delta = \{\delta_1, \dots, \delta_s\}$ be the core curves of the cylinders in the families H and V respectively. Prove that:

1. γ and δ are multicurves in M (that is, their components are simple closed curves, pairwise non-intersecting and pairwise non-homotopic).
2. The multicurves fill the surface, that is $M \setminus (\gamma \cup \delta)$ is a finite union of discs, possibly punctured.

Now assume furthermore that all the cylinders in H and V have modulus $1/\lambda$ and let $E = (E_{ij})_{1 \leq i \leq r, 1 \leq j \leq s}$ be the matrix whose coefficient E_{ij} is the geometric intersection between γ_i and δ_j (i.e. the number of time they intersect). Let also $\mathbf{w}_h \in \mathbb{R}_+^r$ and $\mathbf{w}_v \in \mathbb{R}_+^s$ be the vectors of heights of cylinders in H and V .

3. Show that the circumferences of horizontal (respectively vertical) cylinders are given by the coordinates of the vector $E\mathbf{w}_v$ (resp. $E^t\mathbf{w}_h$).
4. Deduce that $E\mathbf{w}_v = \lambda\mathbf{w}_h$ and $E^t\mathbf{w}_h = \lambda\mathbf{w}_v$.
5. Applying Perron-Frobenius theorem to EE^t and E^tE show that λ is uniquely determined by the matrix E and that the pair $(\mathbf{w}_h, \mathbf{w}_v)$ is uniquely determined up to scaling.
6. Show that the vector $(\mathbf{w}_h, \mathbf{w}_v) \in \mathbb{R}^{r+s}$ is an eigenvector with eigenvalue λ of the $(r+s) \times (r+s)$ matrix $\begin{pmatrix} 0 & E^t \\ E & 0 \end{pmatrix}$.
7. Show that there exists a unique affine multitwist ϕ_h (respectively ϕ_v) with $D\phi_h = h_\lambda$ (resp. $D\phi_v = v_{-\lambda}$) that preserves the cylinder decomposition H (resp. V) and acts in each cylinder as a Dehn twist.

We now propose the Thurston-Veech construction as another exercise.

Exercise 1.2.25

Let $\gamma = \{\gamma_1, \dots, \gamma_r\}$ and $\delta = \{\delta_1, \dots, \delta_s\}$ be two transverse multicurves that fill a finite-type surface S (possibly with punctures). Let $E := (e_{ij})_{1 \leq i \leq r, 1 \leq j \leq s}$ the matrix of geometric intersection numbers.

1. Show that there is a unique half-translation structure q on S (up to isotopy) and a unique positive real number λ so that (S, q) admits horizontal and vertical affine multitwists ϕ_h and ϕ_v with derivatives $D\phi_h = h_\lambda$ and $D\phi_v = v_{-\lambda}$ that act as the product of the Dehn twists along the curves γ_i and δ_j respectively.

Now, let us consider the general Thurston-Veech construction by fixing multiplicities $\mathbf{m} = (m_1, \dots, m_r) \in \mathbb{N}^r$, $\mathbf{n} = (n_1, \dots, n_s) \in \mathbb{N}^s$. Define the two $r \times s$ matrices F_h and F_v by:

$$(F_h)_{ij} = m_i E_{ij} \quad (F_v)_{ij} = E_{ij} n_j.$$

2. Show that there exists $\lambda, \mathbf{w}_h, \mathbf{w}_v$ so that $F_h\mathbf{w}_h = \lambda\mathbf{w}_v$ and $F_v^t\mathbf{w}_v = \lambda\mathbf{w}_h$.
3. What can be said about uniqueness of λ, \mathbf{w}_h and \mathbf{w}_v ?
4. Deduce that there is a unique half-translation structure q on S (up to isotopy) that admits two affine multitwists ϕ_h and ϕ_v with derivative h_λ and $v_{-\lambda}$ and act as the product of the m_i -th power of the Dehn twist along the curves γ_i and the product of the n_j -th power of the Dehn twist along the curves δ_j respectively.

An avid reader can consult the details in the original articles [Thu88], [Vee89] or the more recent [HL06] or [Lei04].

Exercise 1.2.26

Apply the Thurston-Veech construction of Exercise 1.2.25 to the two multicurves C_h and C_v and vectors $\mathbf{m} = (1, 1)$ and $\mathbf{n} = (1, 1)$ in the following genus 2 surface

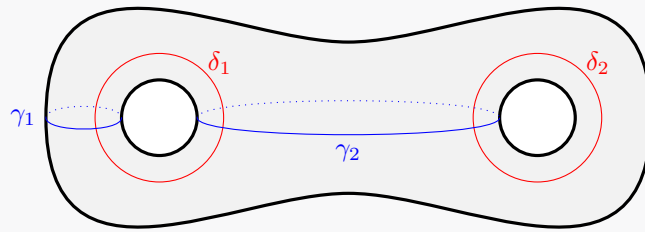

Make a flat picture of the surface and compute its stratum.

Exercise 1.2.27

Let $\gamma = \{\gamma_i\}_{i=1,\dots,r}$ and $\delta = \{\delta_j\}_{j=1,\dots,s}$ be two transverse multicurves filling a topological surface S . Let M be the half-translation surface with underlying topological surface S obtained from the Thurston-Veech construction (see Exercise 1.2.25).

1. Show that the angles of the conical singularities of M can be read from the multicurves: there is exactly one conical singularity in each component U of the complement of $S \setminus (\gamma \cup \delta)$ and its angle is the number of components of γ (or equivalently δ) that bound U .
2. Deduce that the poles come from bigons and hence need to be in components of $S \setminus (\gamma \cup \delta)$ containing at least one puncture.
3. Show that M is a translation surface (i.e. the quadratic differential is a square of an Abelian differential) if and only if there exists a coherent way of orienting the multicurves so that their geometric intersection coincides with the algebraic intersection.
4. Deduce that the stratum in which the half-translation surface belongs only depends on γ and δ and is not affected by the possible multiplicity vectors \mathbf{m} and \mathbf{n} .
5. Construct an example of Thurston-Veech construction in the principal stratum of genus 2 surfaces $\mathcal{Q}(1, 1, 1, 1)$.

Example 1.2.28. The horizontal and vertical directions in the infinite staircase S (see Section 1.2.3) define two transverse cylinder decompositions. The moduli of all these cylinders is equal to $\frac{1}{2}$ and there exist "generalized multitwists" ϕ_h and ϕ_v with derivatives h_2 and v_{-2} that act as a single Dehn twist in each cylinder. This is a particular case of an infinite Thurston-Veech construction that is due to Hooper [Hoo15] and that we call the Hooper-Thurston-Veech construction. All details regarding this construction are given in Section 3.5.

Let us recall that for the finite Thurston-Veech construction the translation structure is unique up to scaling (this is a consequence of Perron-Frobenius theorem as we saw in Exercise 1.2.25). This is not the case anymore for the Hooper-Thurston-Veech construction! Let us consider $\lambda > 2$. The equation $x^2 - \lambda x + 1$ has two distinct positive real roots $r_+ := \frac{\lambda + \sqrt{\lambda^2 - 4}}{2}$ and $r_- := \frac{1}{r_+}$. Let $\mathbf{w}_n := r_+^n$ for $n \in \mathbb{Z}$. This sequence satisfies the equation

$$\mathbf{w}_{n-1} + \mathbf{w}_{n+1} = \lambda \mathbf{w}_n. \quad (1.9)$$

Now we construct an infinite-type surface called the λ -staircase by gluing horizontal cylinders of height \mathbf{w}_{2n} with vertical cylinders of height \mathbf{w}_{2n+1} in the same pattern as the original infinite staircase, see Figure 1.19. Because of equations (1.9), all horizontal and vertical cylinders in the translation surface S_λ have modulus $1/\lambda$. For this reason they admit generalized multitwists with derivatives h_λ and $v_{-\lambda}$. We denote G_λ the group generated by h_λ and v_λ . The following result describes the dynamics of the translation flow on λ -staircases (we refer the reader to Appendix B.2 for a detailed study of G_λ).

Theorem 1.2.29

Let $\lambda > 2$ and S_λ be the λ -staircase built from the sequence $\mathbf{w}_n = \left(\frac{\lambda + \sqrt{\lambda^2 - 4}}{2}\right)^n$. Then the Veech group of S_λ is the group generated by G_λ and $\begin{pmatrix} r_+ & 0 \\ 0 & r_- \end{pmatrix}$. The Veech group identifies to the affine

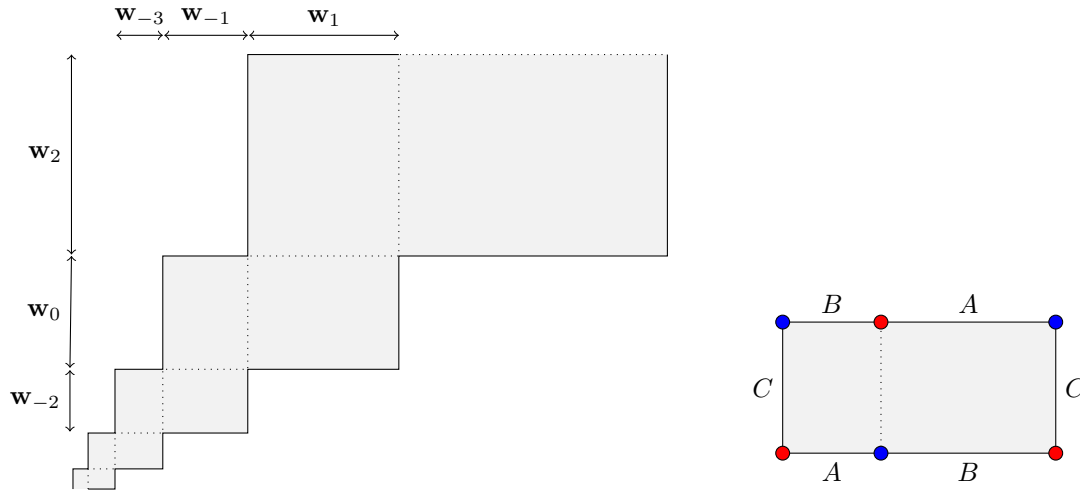

Figure 1.19: On the left: the λ -staircase with $\lambda = 27/13$ (opposite sides are identified by translation). On the right, the dilation surface obtained by quotienting the left picture by the affine dilation.

group via the derivative map. Moreover:

1. if θ is a parabolic direction of G_λ (i.e. fixed by a conjugate of ϕ_h or ϕ_v) then the translation flow in direction θ decomposes S_λ into an infinite union of cylinders of modulus $1/\lambda$,
2. if the direction θ is in the limit set of G_λ but neither parabolic nor fixed by a conjugate of $\phi_h\phi_v$ then F_θ^t is ergodic. Moreover there exists a direction θ' so that the translation flow in S_λ in direction θ is conjugate to the translation flow in S in direction θ' up to a time change.
3. if the direction θ does not belong to the limit set of G_λ or is fixed by a conjugate of $\phi_h\phi_v$ then the translation flow F_θ^t in direction θ in S_λ is completely dissipative,

The last item of Theorem 1.2.29 can be thought as an analogue of the two infinite strips in direction $\theta = \pi/4$ in the original staircase that were stabilized by the product $\begin{pmatrix} 1 & 2 \\ 0 & 2 \end{pmatrix} \begin{pmatrix} 1 & 0 \\ -2 & 1 \end{pmatrix}$ (see Theorem 1.2.11). In the situation of the λ -staircase, these two strips somehow persist but in the form of an infinite flat geodesic on which all other geodesic accumulate. This attracting flat geodesic is persistent in a whole open interval corresponding to a complement of the limit set of G_λ that is delimited by two directions stabilized by two conjugates of $\phi_h\phi_v$. In order to study this phenomena it will be convenient to consider the quotient of S_λ by the unique affine homeomorphism with derivative $\begin{pmatrix} r_+ & 0 \\ 0 & r_- \end{pmatrix}$, see Figure 1.19. The quotient is no longer a translation surface but a *dilation surface*: there is an atlas whose transition maps are dilations $z \mapsto az + b$ with $a \in \mathbb{R}$ and $b \in \mathbb{C}$ (see Definition 2.2.14).

Dilation surfaces are discussed in Section 2.2. In Section 3.5 we introduce the Hooper-Thurston-Veech construction and discuss their geometry. In Chapter 6 we will explore the dynamical properties of Hooper-Thurston-Veech constructions and dilation surfaces.

1.2.7 Random models

In this section we discuss some random models of infinite-type translation surfaces. They are random in the sense that they depend on some parameters and we would like to understand the dynamics of the translation flow for a given random parameter. They might be thought as “translation flows in random environment”.

There are two distinct ways of considering a random parameter. Either in the topological sense: we want to understand the dynamics for a G_δ -dense set of parameters (*generic parameter*), or in the probabilistic sense: for a full-measure set of parameters (*typical parameter*). The topological version and the measurable version lead to different kinds of questions. For example, considering rotations of the circle, the set of Liouville numbers¹³ forms a G_δ -dense set in $[0, 1]$ but has zero Lebesgue measure. In more general situation, it is often the case that the parameters that are very well approximated by rational numbers form G_δ -dense sets. For example, in [KMS86] S. Kerckhoff, H. Masur and J. Smillie

¹³A real number in $\alpha \in [0, 1]$ is called *Liouville* if its continued fraction expansion $[0; a_1, a_2, \dots]$ is so that $\lim a_n = +\infty$.

prove the existence of a G_δ -dense set of polygons whose billiard flow is ergodic. This result is (easily) derived from the (hard) fact that ergodicity is prevalent in rational polygons.

Málaga map. We now consider the maps $T_{\underline{\alpha}}$ introduced by A. Málaga in her PhD thesis [M14]. As we see later they can be thought as the first-return map of the translation flow on particular class of infinite-type translation surfaces called *generalized staircases*.

Let $I = [0, 1) \times \mathbb{Z}$, and denote $I_n = [0, 1) \times \{n\}$. Let $\underline{\alpha} = (\alpha_n)_{n \in \mathbb{Z}}$ be a sequence of numbers in $[0, 1)$ and $f : [0, 1) \rightarrow \{1, -1\}$ the piecewise constant map with value 1 on $[0, 1/2)$ and -1 on $[1/2, 1)$. We define a map $T_{\underline{\alpha}} : I \rightarrow I$ by

$$T_{\underline{\alpha}}(x, n) = (x + \alpha_n \pmod{1}, n + f(x + \alpha_n \pmod{1})). \quad (1.10)$$

In other words, if we are on an interval I_n at level n we rotate first by an angle α_n and, depending on which half of I_n we land on, the point $x + \alpha_n$ either climbs to the interval I_{n+1} or descends to I_{n-1} . When the parameter $\underline{\alpha}$ is a constant sequence then this map encodes the dynamics of the translation flow on the infinite staircase 1.2.3 in a given direction.

It is easy to check that the Lebesgue measure λ on I is invariant by the transformation $T_{\underline{\alpha}}$. Therefore there is room for many standard questions from the (infinite) ergodic theory point of view: *e.g.* conservativity and ergodicity. To go beyond these cases, it is often simpler to state results about the dynamics of the map $T_{\underline{\alpha}}$ that are valid only for a subset of parameters $\underline{\alpha}$. In that sense $T_{\underline{\alpha}}$ is a random model since we are interested in picking the sequence $\underline{\alpha}$ at random and then study the dynamics.

The only known strategy to prove results on the maps $T_{\underline{\alpha}}$ is based on the fact that the value $\alpha_n = 1/2$ creates a barrier (see Figure 1.20).

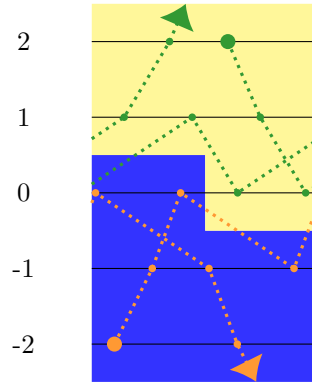

Figure 1.20: A Málaga map with $\alpha_0 = 1/2$. Any trajectory starting at a negative (respectively positive) level n will remain in non-positive levels (resp. non-negative levels) forever.

Theorem 1.2.30

Let $\underline{\alpha}$ be a sequence so that $1/2$ is both an accumulation point of $(\alpha_n)_{n \geq 0}$ and $(\alpha_n)_{n \leq 0}$. Then the map $T_{\underline{\alpha}}$ is conservative, that is, almost every orbit comes back arbitrarily close to its starting point.

This theorem is a consequence of the so-called *boxes lemma* that will be introduced in Section 5.2. As a result, one has

Corollary 1.2.31. *Let μ be the Lebesgue measure on $[0, 1)$. Then for $\mu^{\otimes \mathbb{Z}}$ -almost every $\underline{\alpha} \in [0, 1)^{\mathbb{Z}}$, the map $T_{\underline{\alpha}}$ is recurrent.*

Proof of Corollary 1.2.31. We claim that if $(X_n)_{n \geq 0}$ is a sequence of independent and identically distributed uniform random variables in $[0, 1)$ then for almost every ω and for any $s \in [0, 1)$ there exists a divergent sequence of positive integers $(n_k)_k$ so that

$$\lim_{k \rightarrow \infty} X_{n_k}(\omega) = s.$$

Assuming the claim with the value $s = 1/2$ one can apply Theorem 1.2.30.

The proof of the claim is a standard probability argument. Any non-empty open set U in $[0, 1)$ has positive Lebesgue-measure. Hence almost surely, $X_n \in U$ for infinitely many n . One then concludes by considering the countable collection of open balls $B_{q,k}$ centered at rational points q with radius $1/k$ and the fact that a countable intersection of almost sure events is almost sure. \square

Contrarily to recurrence properties, ergodicity needs quantitative estimates. The only result in this direction for the maps $T_{\underline{\alpha}}$ is also due to Málaga.

Theorem 1.2.32

The set of parameters $\underline{\alpha}$ in $[0, 1)^{\mathbb{Z}}$ for which $T_{\underline{\alpha}}$ is minimal and ergodic contains a dense G_{δ} set.

Recall the infinite staircase that was introduced in example 1.2.3. We now consider staircases where each step has width 2 but can have any height. Given a bi-infinite sequence of positive real numbers $\underline{h} = (h_n)_{n \in \mathbb{Z}}$ we consider the rectangles $R_n := [0, 2] \times [0, h_n]$. From them we build the translation surface $M_{\underline{h}}$ by performing for each $n \in \mathbb{Z}$ the following identifications by translations:

- the left side of R_n is glued to its right side,
- the left half of the top side of R_n , $[0, 1] \times \{h_n\}$ is glued to the right part of the bottom side of R_{n-1} , $[1, 2] \times \{0\}$,
- the right part of the top side of R_n , $[1, 2] \times \{h_n\}$ is glued to the left part of the bottom side of R_{n-1} , $[0, 1] \times \{0\}$.

We call the surface $M_{\underline{h}}$ the \underline{h} -infinite staircase or simply a generalized staircase. An example can be seen in Figure 1.21.

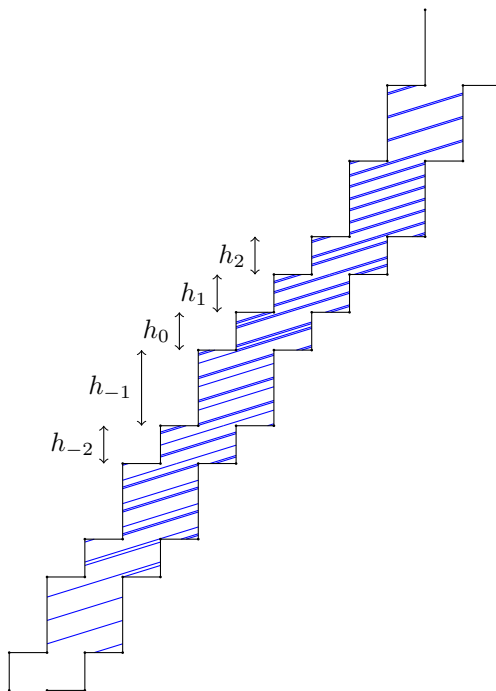

Figure 1.21: An orbit in some \underline{h} -staircase where each height h_n is either 1 or 2. This example is an infinite origami. The first return map of the translation flow can be identified with a map $T_{\underline{\alpha}}$ for a certain sequence $\underline{\alpha}$.

The following result makes the link between the generalized staircases and Málaga maps. The definition of first return map can be found in Chapter 4.

Lemma 1.2.33. *Let $M_{\underline{h}}$ be a generalized staircase. Then for each direction θ that is not horizontal, the first return map of the translation flow $F_{S_{\underline{h}, \theta}}^t$ to the union of the horizontal sides of the rectangles R_n canonically identifies with the Málaga map $T_{\underline{\alpha}}$ with angles $\alpha_n = h_n \tan(\theta) + 1/2 \pmod{1}$.*

It is interesting to notice that a fixed generalized staircase $M_{\underline{h}}$ gives rise to a one-parameter family of Málaga maps. The proof of this Lemma is provided in Exercise 4.2.1. In the exercise below we just invite the reader to prove elementary properties of the Málaga map $T_{\underline{\alpha}}$ and the generalized staircase $M_{\underline{h}}$.

Exercise 1.2.34

1. Under which condition does the surface $M_{\underline{h}}$ have finite area?
2. Show that if μ is a Borel measure on $(0, +\infty)$ then for $\mu^{\otimes \mathbb{Z}}$ -almost every sequence \underline{h} the surface $M_{\underline{h}}$ has infinite area.
3. Show that if $\underline{\alpha}$ is an infinite sequence whose values are $1/3$ and $2/3$ (in any order) then in each interval I_n at least $2/3$ of the points has a divergent orbit. (*hint: the partition in intervals of the form $(k/6, (k+1)/6) \times \{n\}$ is preserved by $T_{\underline{\alpha}}$. One just needs to study the associated map on the discrete set $\{0, 1, 2, 3, 4, 5\} \times \mathbb{Z}$).*

Theorem 1.2.30 implies the following result for $M_{\underline{h}}$.

Corollary 1.2.35. *Let μ be a probability measure on $(0, +\infty)$ whose support contains a half-line. Then for $\mu^{\otimes \mathbb{Z}}$ -almost every sequence \underline{h} the translation flow in $M_{\underline{h}}$ is conservative in all directions.*

Note that contrarily to the infinite staircase from Example 1.2.3, the randomized version given in the above corollary is recurrent in *all* directions! However, the ergodic result of Theorem 1.2.32 hardly applies to a surface $M_{\underline{h}}$ in almost every direction. The following two questions are widely open.

Question 1.2.36

Let μ be the Lebesgue measure on $[0, 1)$. Is $T_{\underline{\alpha}}$ ergodic for $\mu^{\mathbb{Z}}$ -almost every $\underline{\alpha}$?

Question 1.2.37

Let μ be the measure supported on $\{1, 2\}$ with $\mu(\{1\}) = \mu(\{2\}) = 1/2$. Is the straightline flow of $M_{\underline{h}}$ ergodic in almost every directions for $\mu^{\mathbb{Z}}$ -almost every \underline{h} ?

Random wind-tree models. We finish this section by introducing random variations of the periodic wind-tree model introduced in Section 1.2.4.

Given $\underline{\omega} \in \{0, 1\}^{\mathbb{Z}^2}$ we define a billiard on a generalized polygon $T(\underline{\omega})$ as follows. For each position $(m, n) \in \mathbb{Z}^2$ so that $\omega_n = 1$ we place a square obstacle with side length $1/2$ and consider the billiard in the complement of the obstacles. For the constant sequence $\omega_{m,n} = 1$ the generalized polygon $T(\underline{\omega})$ is the usual wind-tree model table $T_{1/2, 1/2}$ with dimensions $a = b = \frac{1}{2}$ (see Section 1.2.4 for the geometric meaning of the parameters a and b). While for $\omega_{m,n} = 0$ we recover the plane (\mathbb{C}, dz) . As for the windtree, one can consider the 4-fold cover giving rise to a translation surface $W(\underline{\omega})$.

The only sensible known result about this model is the existence of configurations in which the translation flow is conservative.

Theorem 1.2.38: [Tro10]

The set of parameters $\underline{\omega}$ for which the translation flow on the translation surface $W(\underline{\omega})$ is conservative in almost every direction contains a G_δ -dense set.

The tools used to prove this theorem are the same as the ones used to prove Theorem 1.2.30 and Corollary 1.2.35. However the conclusion is much weaker because in order to create barriers in this 2-dimensional coverings one needs a 1-dimensional crown of obstacles.

We now describe the Bernoulli wind-tree model (see Figure 1.22). For any given parameter $0 < p < 1$ we consider a sequence $\underline{\omega} \in \{0, 1\}^{\mathbb{Z}^2}$ where each $\omega_{m,n}$ is chosen according to an independent Bernoulli random variable with parameter p . In other words, for each point (m, n) in the lattice \mathbb{Z}^2 toss a coin which lands on your favourite side with probability p . If for (m, n) the coin lands on your favourite side place an obstacle at position (m, n) . We denote this product of Bernoulli measures on $\{0, 1\}^{\mathbb{Z}^2}$ by μ_p .

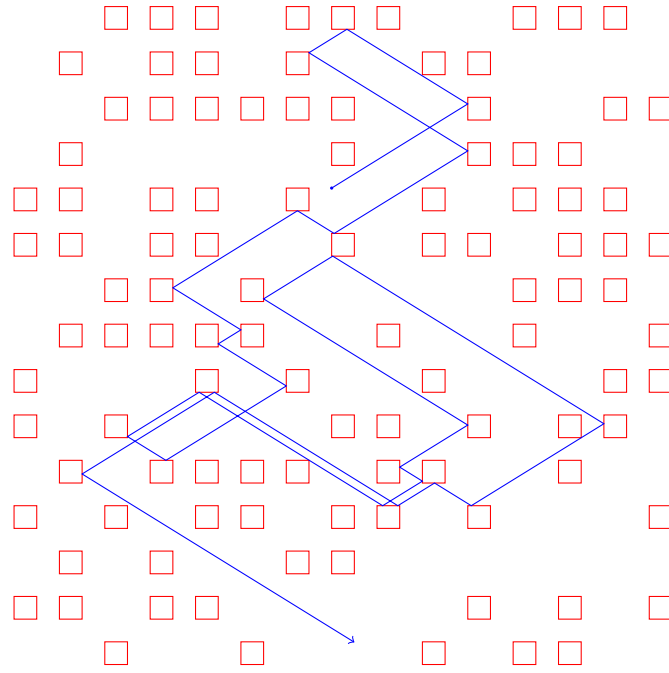

Figure 1.22: A trajectory in a Bernoulli wind-tree model with $p = 1/2$.

Question 1.2.39

For a given parameter p , what are the dynamical properties of $W(\underline{\omega})$ where $\underline{\omega}$ is taken accordingly to the product of Bernoulli measures μ_p ?

Recall that the original Ehrenfests' wind-tree model concerns obstacles that are not displaced along a lattice. The natural way to choose at random a countable set of points in the plane is by a Poisson point process¹⁴. It is well known that the Poisson point process with density δ can be obtained as the limit of the Bernoulli point processes with probability $\delta\varepsilon^2$ on the lattice $\varepsilon\mathbb{Z}^2$. Any result relating the dynamics of the Bernoulli wind-tree model to the Ehrenfests' wind-tree one would be really interesting.

1.2.8 Holomorphic foliations

Every integral curve of a complex vector field can be endowed with a natural translation surface structure. We illustrate this principle in the following paragraphs by giving explicit examples of complex differential equations whose leaves are, as translation surfaces, precisely those we obtained by unfolding a triangular billiard table in Section 1.2.1. As a consequence, one can reformulate the problem of finding periodic orbits on a triangular billiard in terms of a real quadratic vector field in \mathbb{R}^4 .

Consider the complex differential equations in \mathbb{C}^2 :

$$\begin{aligned}\frac{\partial z_1}{\partial T} &= \lambda_2 z_1^2 + (\lambda_3 - \lambda_2) z_1 z_2 = P_\lambda(z_1, z_2) \\ \frac{\partial z_2}{\partial T} &= -\lambda_1 z_2^2 + (\lambda_3 + \lambda_1) z_1 z_2 = Q_\lambda(z_1, z_2)\end{aligned}\tag{1.11}$$

where $\lambda = (\lambda_1\pi, \lambda_2\pi, \lambda_3\pi)$ are the interior angles of an Euclidean triangle, in particular $\sum \lambda_i = 1$. These kind of differential equations arise naturally when studying homogeneous holomorphic foliations on \mathbb{C}^2 , for more details see [Val09a] and references within. The integral curves of the vector field $V_\lambda = P_\lambda \frac{\partial}{\partial z_1} +$

¹⁴The *Poisson point process with density δ* is a way of choosing randomly a countable set of points in the plane. It is defined by a probability measure μ_δ on countable subsets of \mathbb{R}^2 that can be defined by the following property. For any open set U in \mathbb{R}^2 the expected number of points in U is $\delta \text{Area}(U)$, in other words

$$\int \#(\Gamma \cap U) d\mu_\delta(\Gamma) = \delta \text{Area}(U).$$

The interested reader might want to consult [CI80] or [DVJ03].

$Q_\lambda \frac{\partial}{\partial z_2}$ defined by equation (1.11) define a (singular) holomorphic foliation \mathcal{F}_λ on \mathbb{C}^2 . This foliation has $F(z_1, z_2) = z_1^{\lambda_1} z_2^{\lambda_2} (z_2 - z_1)^{\lambda_3}$ as first integral, *i.e.* the irreducible components of $F^{-1}(w)$, $w \in \mathbb{C}$, in $\mathbb{C}^2 \setminus \{(0, 0)\}$ are precisely the leaves of \mathcal{F}_λ and the origin is the only singular leaf. Moreover, \mathcal{F}_λ is invariant by the action of the homothety group \mathbb{C}^* and hence every two leaves in $\mathbb{C}^2 \setminus \{(0, 0) \cup F^{-1}(0)\}$ are diffeomorphic. We call any leaf of \mathcal{F}_λ in $\mathbb{C}^2 \setminus \{(0, 0) \cup F^{-1}(0)\}$ a *generic leaf*.

Let us now endow a generic leaf $\mathcal{L} \in \mathcal{F}_\lambda$ with a translation surface structure. Let $V_\lambda|_{\mathcal{L}}$ be the restriction of the complex vector field V_λ to its integral curve \mathcal{L} . Consider the holomorphic 1-form η on \mathcal{L} satisfying the equation $\eta(V_\lambda|_{\mathcal{L}}) = 1$ (this form is unique because the leaves have complex dimension 1). The pair (\mathcal{L}, η) is a translation surface. The following result relates the foliation \mathcal{F}_λ to triangular billiards introduced in Example 1.2.1.

Theorem 1.2.40: [Val09a]

Let $(\lambda_1\pi, \lambda_2\pi, \lambda_3\pi)$ be the interior angles of an Euclidean triangle P and $\mathcal{L} \in \mathcal{F}_\lambda$ a generic leaf endowed with its natural translation surface structure. Then (\mathcal{L}, η) is isomorphic, as translation surface, to the translation surface $M(P)$ obtained by performing the unfolding construction on P .

We will sketch a proof of this theorem in Section 2.2.

This correspondence between integral curves of V_λ and translation surfaces defined by triangular billiards can be extended to the level of billiard dynamics. Indeed, let $\mathcal{F}_{\lambda,0}$ be the real foliation on \mathbb{C}^2 defined by the integral curves of the real analytic vector field $\text{Re}(V_\lambda)$. This vector field is quadratic and homogeneous and the restriction of $\mathcal{F}_{\lambda,0}|_{\mathcal{L}}$ is a real foliation of dimension 1 on \mathcal{L} . For every generic leaf $\mathcal{L} \in \mathcal{F}_\lambda$ denote by $re^{i\theta}\mathcal{L}$ the image of the restriction to \mathcal{L} of the homothety $T_{re^{i\theta}}(z_1, z_2) := re^{i\theta}(z_1, z_2)$.

Corollary 1.2.41 ([Val09a]). *Let $(\lambda_1\pi, \lambda_2\pi, \lambda_3\pi)$ be the interior angles of an euclidean triangle P . For every generic leaf $\mathcal{L} \in \mathcal{L}_\lambda$ there exists a direction $\theta \in \mathbb{S}^1$ such that the real foliation $\mathcal{F}_{\lambda,0}|_{\mathcal{L}}$ is analytically conjugated to the foliation on $M(P)$ defined by the translation flow F_θ^t . Moreover, for every $\theta' \in \mathbb{S}^1$, $\mathcal{F}_{\lambda,0}|_{re^{i\theta'}\mathcal{L}}$ is analytically conjugated to the foliation on $M(P)$ defined by the translation flow $F_{\theta+\theta'}^t$.*

This corollary allows us to reformulate the open question about the existence of periodic trajectories in a polygonal billiard in terms of a homogeneous quadratic vector field (see Question 1.2.1).

Question 1.2.42

Does the homogeneous quadratic vector field in \mathbb{R}^4 :

$$\begin{aligned} 2\text{Re}(V_\lambda) = & [\lambda_2(x_1^2 - y_1^2) - (\lambda_2 + \lambda_3)(x_1x_2 - y_1y_2)]\partial/\partial x_1 + \\ & [2\lambda_2x_1y_1 - (\lambda_2 + \lambda_3)(x_1y_2 + x_2y_1)]\partial/\partial y_1 + \\ & [\lambda_1(x_2^2 - y_2^2) - (\lambda_1 + \lambda_3)(x_1x_2 - y_1y_2)]\partial/\partial x_2 + \\ & [2\lambda_1x_2y_2 - (\lambda_1 + \lambda_3)(x_1y_2 + x_2y_1)]\partial/\partial y_2 \end{aligned} \tag{1.12}$$

have a periodic orbit for any choice of parameters $(\lambda_1\pi, \lambda_2\pi, \lambda_3\pi)$ representing the interior angles of an euclidean triangle P ?

Remark 1.2.43. As a careful reader might have noticed, the vector field (1.12) is defined on \mathbb{R}^4 whereas the phase space of a triangular billiard has dimension 3. Since this vector field is defined by homogeneous polynomials of degree 2, it is possible to consider its projectivization to either \mathbb{S}^3 or $\mathbb{RP}(3)$. We refer to [Val09a] for details.

