

# Unfoldings for general Petri Nets\*

Jean-Michel Couvreur<sup>†</sup> Denis Poitrenaud<sup>‡</sup> Pascal Weil<sup>§</sup>

December 23, 2004

## Abstract

We propose a new model of branching processes, suitable for describing the behavior of general Petri nets, without any finiteness of safeness assumption. In this framework, we define a new class of branching processes and unfoldings of a net  $N$ , which we call true. These coincide with the safe branching processes and unfoldings if  $N$  is safe, or weakly safe as in [Engelfriet 1991], but not in general. However, true branching processes and processes satisfy the good order-theoretic properties which make the safe processes of safe nets so useful in practice, and which are known to not hold for the safe processes of a general net. True processes represent therefore good candidates to generalize the theory of safe nets to the general case.

## 1 Introduction

The study of the behavior of models of concurrency usually requires the definition of more abstract models. Within the framework of Petri nets, primarily two models were retained: labeled occurrence nets and event structures. Both models were proposed by Nielsen, Plotkin and Winskel in their foundational paper [7], in order to give a semantic of concurrency for safe Petri nets. The description of a safe Petri net execution is presented by a labeled causal net, called a process. Roughly speaking, causal nets are acyclic Petri nets whose places are without branching. In particular, their places and transitions are partially ordered, and this order, restricted to transitions, induces a partial order on the transition occurrences in the original Petri net. For the representation of conflictual behaviors, branching on places is authorized. This leads

---

\*This paper was prepared in part while the first author was on a 2-year assignment at LSV (ENS Cachan) with the support of CNRS. The third author acknowledges partial support from Project VERSYDIS, ACI *Sécurité informatique*, Ministère de l'Industrie.

<sup>†</sup>LaBRI, Université de Bordeaux I, Talence, France, [couvreur@labri.fr](mailto:couvreur@labri.fr)

<sup>‡</sup>LIP6, Université Pierre et Marie Curie, Paris, France, [denis.poitrenaud@lip6.fr](mailto:denis.poitrenaud@lip6.fr)

<sup>§</sup>LaBRI, CNRS, Talence, France, [pascal.weil@labri.fr](mailto:pascal.weil@labri.fr)

to the definition of labeled occurrence nets, called branching processes. The set of all the behaviors of the system can be captured by a single branching process, called the unfolding of the system, whose transitions are called events. By restricting the relations of causality and conflict to events, one obtains an event structure called the prime event structure. Since the publication of [7], there has been many attempts to extend these results to general Petri nets.

In these attempts, the focus has often been on using the same classes as in the case of safe nets, namely causal and occurrence Petri nets. Engelfriet [2] restricted his work to 1-valued, initially 1-marked Petri nets, and he obtained good algebraic properties on branching processes (a structure of lattice) which led to the concept of unfolding.

For others (e.g. Best and Devillers [1], Meseguer, Montanari and Sassone [5]), tokens are individualized. As argued in [4], this is contrary to a pure multiset view of general nets, and the systems modelled by Petri nets rarely justify individualizing tokens. Similarly, Haar [3], pursuing Vogler's work [8], proposes an approach which aims at translating general nets into safe nets, by introducing a place for each reachable marking of original places. This not only considerably increases the size of the structure, but it also artificially introduces conflicts between transitions that access a given place. Thus it strongly departs from the intended semantic of nets.

In contrast with these approaches, Hoogers, Kleijn and Thiagarajan [4], propose a new event structure. In this so-called local event structure, tokens are not colored. Their theory is complete for co-safe nets (see [4]), and it can be extended to the case of general nets. However, it does not present the expected properties in the general case.

In this paper, we propose a more net-theoretic approach, which does not impose coloring the tokens, and which incorporates the solutions of [1, 2, 5]. Our formal framework allows us to identify a new structure, called true unfolding, which allows for the good algebraic properties identified by Engelfriet [2], and which is applicable to general nets.

The starting point of our approach is an extension of the definitions of occurrence nets, which can be arbitrarily valued and non-safe, and of configurations, which are multisets of transitions. Branching processes are defined as occurrence nets labeled by the elements of the original net. The set of branching processes of a net is equipped with a natural order relation, which leads to the definition of unfoldings as maximal branching processes.

We identify two classes of branching processes and two types of unfoldings: safe and true. The safe case coincides with those of [1, 2, 5]. The true case is more interesting because of its order-theoretic properties. For safe nets, and more generally under the constraints on the net structure identified by Engelfriet in [2], there exists a unique unfolding, and the concepts of safe and true unfolding coincide. In general however, the two unfoldings differ.

We also formalize the concept of process in our multiset context. Contrary to other works, our definition is not based on causal nets, but on the concept of a configuration. Again, it turns out that the safe case does not offer good enough properties (*e.g.*, we cannot define the greatest lower bound of two processes). In contrast, the expected properties hold for true processes. This comes from the fact that a true process is represented in a unique way in the true unfolding.

The drawback of these algebraically and order-theoretically satisfactory structures is that the concepts of conflict and causality are not any more explicitly given by the model structure. That is, we lose a direct link with prime event structures, as in [4].

The paper is organized as follows. In Section 2, we fix the notation for nets, homomorphisms of nets and other fundamental objects. Section 3 discusses occurrence nets and configurations. In Section 4, generalized branching processes and unfoldings are introduced, and the properties of true and safe branching processes and unfoldings are compared. Finally Section 5 presents the generalized notion of processes, and establishes the order-theoretic properties of true processes. Counter-examples of these properties for safe processes are also presented.

## 2 Preliminaries

We first summarize the basic notation and concepts used in this paper, concerning multisets and Petri nets.  $\mathbb{N}$  denotes the set of non-negative integers.

### 2.1 Notation

Let  $X$  be a set. A *multiset* over  $X$  is a mapping  $v: X \rightarrow \mathbb{N}$ . Multisets are often represented as formal linear combinations, *e.g.*  $v = a + 2b$  for  $v(a) = 1$ ,  $v(b) = 2$ ,  $v(c) = 0$  for all  $c \in X \setminus \{a, b\}$ , and it is also convenient to view them as vectors in  $\mathbb{N}^X$ . The *support* of the multiset  $v$  is the set  $\bar{v} = \{x \in X \mid v(x) > 0\}$ . Note that the support of a multiset may be infinite. A multiset over a set  $X$  can be naturally considered as a multiset over any superset of its support.

The operations of addition and subtraction of multisets over  $X$  are defined componentwise, as on vectors (note however that negative coefficients are not allowed). An infinite sum of multisets  $v = \sum_{i \in I} v_i$  is said to be *well-defined* if for each  $x \in X$ , the sum  $\sum_{i \in I} v_i(x)$  is finite, if and only if each  $x \in X$  sits in the support of finitely many  $v_i$ . If  $\sigma = x_1 x_2 \cdots$  is a sequence of elements of  $X$ , finite or not, the *characteristic vector* of  $\sigma$  is the multiset  $\sigma = \sum_{i=1}^{|\sigma|} x_i$ . Multisets are partially ordered by letting  $v \leq w$  if  $v(x) \leq w(x)$  for each  $x \in X$ .

If  $X$  and  $Y$  are sets, a mapping  $h: X \rightarrow Y$  can be partially extended to multisets,  $h: \mathbb{N}^X \rightarrow \mathbb{N}^Y$ , by letting  $h(v) = \sum_{x \in X} v(x)h(x)$  if the sum is well-defined (that is, if each  $y \in Y$  has finitely many pre-images in the support of  $v$ ).

The mapping  $h$  can also be extended to sequences of elements of  $X$  by letting  $h(x_1x_2\cdots) = h(x_1)h(x_2)\cdots$ .

Let  $\rightarrow$  be a relation on the set  $X$ , for instance the edge relation of a graph in which  $X$  is the set of vertices. We denote by  $\xrightarrow{*}$  (resp.  $\xrightarrow{+}$ ), the reflexive and transitive closure (resp. transitive) of  $\rightarrow$ . We also use the following notation: if  $Y \subseteq X$ ,

$$\begin{aligned} \bullet Y &= \{x \in X \mid \exists y \in Y, x \rightarrow y\} & *Y &= \{x \in X \mid \exists y \in Y, x \xrightarrow{*} y\} \\ Y^\bullet &= \{x \in X \mid \exists y \in Y, y \rightarrow x\} & Y^* &= \{x \in X \mid \exists y \in Y, y \xrightarrow{*} x\}. \end{aligned}$$

When the graph  $(X, \rightarrow)$  is *acyclic* (i.e.  $x \xrightarrow{+} x$  never holds, for any  $x \in X$ ), the relation  $\xrightarrow{*}$  forms a partial order on a set  $X$ .

Finally, if  $(X, \leq)$  is a partially ordered set and if  $Y \subseteq X$ , we say that  $x$  is a *lower* (resp. *upper*) *bound* of  $Y$  if  $x \leq y$  (resp.  $y \leq x$ ) for each element  $y \in Y$ . The *greatest lower bound* (resp. *least upper bound*) of  $Y$ , if it exists, is denoted by  $\inf(Y)$  (resp.  $\sup(Y)$ ). If any two elements of  $X$  admit a lower bound and an upper bound,  $X$  is called a *lattice*. It is a *complete lattice* if any subset of  $X$  admits a lower and an upper bound.

## 2.2 Petri net

A *Petri net*, or simply a *net* (see Murata [6]), is a tuple  $N = (P, T, \text{Pre}, \text{Post}, m_0)$  consisting of two disjoint sets  $P$  and  $T$  whose elements are called *places* and *transitions*, two multisets  $\text{Pre}$  and  $\text{Post}$  over  $P \times T$  (sometimes called the *flow functions*), and a multiset  $m_0$  over  $P$  called the *initial marking*. A *marking* of  $N$  is any multiset over  $P$ . If  $t$  is a transition, the *pre-condition* of  $t$ , written  $\text{Pre}(t)$ , is the marking  $\text{Pre}(\cdot, t)$ . Similarly, the *post-condition* of  $t$ , written  $\text{Post}(t)$  is the marking  $\text{Post}(\cdot, t)$ .

Note that we don't make any finiteness assumption:  $P$  or  $T$  may be infinite, as well as the support of the initial marking. A net may be viewed as a labelled bipartite graph (the graphical representation of  $N$ ) as follows: we can identify  $N$  with the labeled graph  $(P, T, \rightarrow, m_0)$ , where places and transitions are the two disjoint sets of nodes, there is an edge  $p \xrightarrow{\text{Pre}(p,t)} t$  (resp.  $t \xrightarrow{\text{Post}(p,t)} p$ ) between the place  $p$  and the transition  $t$  if  $\text{Pre}(p, t)$  (resp.  $\text{Post}(p, t)$ ) is non-zero, and  $m_0$  is a labelling function of the places, traditionally depicted by the presence of  $m_0(p)$  tokens in place  $p$ .

**Example 2.1** Figure 1 represents the net  $N = (P, T, \text{Pre}, \text{Post}, m_0)$  with  $P = \{A, B, C\}$ ,  $T = \{t\}$ ,  $\text{Pre} = 4(A, t)$ ,  $\text{Post} = 2(B, t) + (C, t)$  and  $m_0 = 5A$ .  $\square$

If  $t$  is a transition and  $m$  is a marking of  $N$ , we say that  $t$  is *enabled* by  $m$ , written  $m[t]$ , if  $\text{Pre}(t) \leq m$ . *Firing the transition  $t$*  in  $m$  produces the marking

$$m' = m + \text{Post}(t) - \text{Pre}(t). \quad \text{(firing rule)}$$

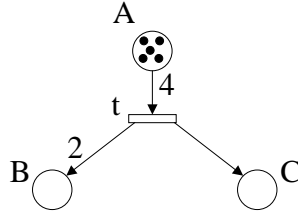

Figure 1: Graphical representation of a net

and we write  $m [t] m'$ . The firing rule is extended inductively to any sequence of transitions: if  $\varepsilon$  is the empty sequence, we let  $m [\varepsilon] m$ ; if  $\sigma$  is a sequence of transitions and if  $t$  is a transition, then  $m [\sigma t] m'$  if there exists a marking  $m''$  such that  $m [\sigma] m''$  and  $m'' [t] m'$ . It is easily verified that if  $\sigma = t_1 t_2 \cdots t_n$  and  $m [\sigma] m'$ , then

$$m' = m + \sum_{i=1}^n \text{Post}(t_i) - \sum_{i=1}^n \text{Pre}(t_i). \quad (\text{extended firing rule}).$$

A transition, or sequence of transitions, is said to be *firable* if it is enabled by the initial marking. A marking  $m$  is called *reachable* if there exists a finite sequence of transitions  $\sigma$  such that  $m_0 [\sigma] m$ . We denote by  $\text{Reach}(N)$  the set of reachable markings of  $N$ .

A transition  $t$  is called *spontaneous* if  $\text{Pre}(t) = 0$ , that is,  $\bullet t = \emptyset$ . A place or a transition  $x$  is called *isolated* if  $\bullet x = x^\bullet = \emptyset$ .

In the sequel, we will discuss a number of properties of nets. Recall that a marking  $m$  is *safe* if  $m(p) \leq 1$  for each place  $p$ . The net  $N$  is said to be

- **finite** if  $P$  and  $T$  are finite sets;
- **elementary** if the pre- and post-condition  $\text{Pre}(t)$  and  $\text{Post}(t)$  of each transition  $t$  are safe markings;
- **weakly safe** if  $N$  is elementary,  $m_0$  is safe and every spontaneous transition is isolated;
- **safe** if each reachable marking is safe;
- **quasi-live** if every transition is enabled by a reachable marking;
- **acyclic** if the graph representing  $N$  is acyclic; in that case, the induced partial order on the set of places and transitions is written  $\leq$ .

Most of these notions are classical [6], except for weakly safe nets, which are new. They occur nevertheless in Engelfriet [2].

**Lemma 2.2** *Every quasi-live, safe Petri net is weakly safe.*

**Proof.** It is clear that if  $N$  is safe, then the initial marking  $m_0$  is safe. We now verify that  $N$  is elementary, that is, the pre- and post-conditions of a transition  $t \in T$  are subsets of  $P$  rather than multisets over  $P$ . As we are assuming that  $t$  is enabled by some reachable marking, and that each reachable marking is safe, the marking  $\text{Pre}(t)$  must be safe. For the same reason, since  $t$  appears in a sequence of transitions enabled by the initial marking, leading to a safe marking, the marking  $\text{Post}(t)$  must be safe as well. This concludes the proof.  $\square$

It is interesting to note that weak safeness is a property that can be easily verified upon reading the definition of a Petri net, whereas deciding safeness requires computing a transitive closure.

For further reference, we note the following technical lemma, which belongs to the folklore.

**Lemma 2.3** *Let  $N$  be an acyclic net, let  $t$  be a transition, and let  $\sigma$  be a minimal length firable sequence of transitions enabling  $t$ . Then every transition  $x$  in  $\sigma$  is such that  $x < t$ .*

**Proof.** We first verify that if a marking  $m$  enables a sequence of 2 transitions  $t_1 t_2$  such that  $\neg(t_1 < t_2)$ , then  $m$  also enables the sequence  $t_2 t_1$ . Indeed, we have  $m \geq \text{Pre}(t_1)$  and  $m - \text{Pre}(t_1) + \text{Post}(t_1) \geq \text{Pre}(t_2)$ . Moreover, no place in the support of  $\text{Post}(t_1)$  is in the support of  $\text{Pre}(t_2)$  (otherwise  $t_1 < t_2$ ). Thus  $m - \text{Pre}(t_1) \geq \text{Pre}(t_2)$ , and this implies  $m \geq \text{Pre}(t_2)$  and  $m - \text{Pre}(t_2) \geq \text{Pre}(t_1)$ . The first inequality shows that  $m$  enables  $t_2$ , and the second inequality shows that the marking obtained from  $m$  by firing  $t_2$  enables  $t_1$ .

Moreover, in this situation, the extended firing rule shows that the markings obtained after firing the sequences  $t_1 t_2$  and  $t_2 t_1$  coincide.

Now let  $\sigma = t_1 t_2 \cdots t_n$  be a sequence of transitions such that  $\sigma t$  is firable and  $n$  is minimal. For each  $1 \leq j \leq n$ , let  $m_j$  be the marking such that  $m_0 [t_1 \cdots t_j] m_j$ . Thus  $m_{i-1}$  enables  $t_i t_{i+1} \cdots t_n t$  for each  $i$ . Now let  $i$  be maximal such that  $\neg(t_i < t)$ . Then  $t_j < x$  for each  $j > i$ , and hence  $\neg(t_i < t_j)$ . Using repeatedly the first statement in this lemma, it follows that  $m_{i-1}$  enables  $t_{i+1} t_i t_{i+2} \cdots t_n t$ , and also  $t_{i+1} t_{i+2} t_i \cdots t_n t$ , etc, and finally  $t_{i+1} \cdots t_n t t_i$ , which contradicts the minimality of  $n$ .  $\square$

### 2.3 Homomorphism of nets

Let  $N = (P, T, \text{Pre}, \text{Post}, m_0)$  and  $N' = (P', T', \text{Pre}', \text{Post}', m'_0)$  be nets. Let  $h: P \cup T \rightarrow P' \cup T'$  be a mapping such that  $h(P) \subseteq P'$  and  $h(T) \subseteq T'$ . We say that  $h$  is a *homomorphism of nets* from  $N$  to  $N'$  (see [2]) if, for each transition  $t \in T$ , we have

- $\text{Pre}'(h(t)) = h(\text{Pre}(t))$ ,
- $\text{Post}'(h(t)) = h(\text{Post}(t))$ ,
- $m'_0 = h(m_0)$ .

In other words, for each  $t \in T$  and  $p' \in P'$ , we have

- $\text{Pre}'(p', h(t)) = \sum_{p \in h^{-1}(p')} \text{Pre}(p, t)$ ,
- $\text{Post}'(p', h(t)) = \sum_{p \in h^{-1}(p')} \text{Post}(p, t)$ ,
- $m'_0(p') = \sum_{p \in h^{-1}(p')} m_0(p, t)$ .

Observe that in this definition,  $h(m_0)$ ,  $h(\text{Pre}(t))$  and  $h(\text{Post}(t))$  must be well-defined, that is, the pre-image  $h^{-1}(p')$  of each place  $p' \in P'$  must have a finite intersection with the support of  $m_0$  and of each pre- and post-condition of a transition of  $N$  (see Section 2.1).

We note the following elementary properties of homomorphisms of nets.

**Lemma 2.4** *Let  $N = (P, T, \text{Pre}, \text{Post}, m_0)$  and  $N' = (P', T', \text{Pre}', \text{Post}', m'_0)$  be nets, and let  $h: N \rightarrow N'$  be a homomorphism.*

- *If a transition  $t$  of  $N'$  sits in the range of  $h$ , then  $\bullet t$  and  $t \bullet$  are contained in the range of  $h$ .*
- *Let  $t \in T$ . If  $\text{Pre}'(h(t))$  (resp.  $\text{Post}'(h(t))$ ) is a safe marking, then the same holds for  $\text{Pre}(t)$  (resp.  $\text{Post}(t)$ ) and  $h$  is injective on  $\bullet t$  (resp.  $t \bullet$ ).*
- *If  $m'_0$  is safe, then  $m_0$  is safe and  $h$  is injective on  $\bar{m}_0$ .*
- *If  $N'$  is elementary (resp. weakly safe), then so is  $N$ .*

**Proof.** The first statement follows directly from the definition of a homomorphism of nets.

Let us verify the second property when  $\text{Pre}'(h(t))$  is safe. By definition of net homomorphisms, for each place  $p' \in \bullet h(t)$  (that is, in the support of  $\text{Pre}(h(t))$ ), we have  $\sum_{p \in h^{-1}(p')} \text{Pre}(p, t) = \text{Pre}'(p', h(t)) = 1$ , so  $h^{-1}(p') \cap \bullet t$  must consist of a single element  $p$ , and  $\text{Pre}(p, t) = 1$ . The result follows since  $h(\bullet t) = \bullet h(t)$ .

The case where  $\text{Post}(t)$  is safe is handled analogously, as is the case where the initial marking  $m_0$  is safe (third property). The last property follows easily.  $\square$

**Proposition 2.5** *Let  $N$  and  $N'$  be Petri nets and let  $h: N \rightarrow N'$  be a homomorphism. Let  $m$  be a marking of  $N$  such that  $h(m)$  is well-defined, let  $t$  be a transition of  $N$  enabled by  $m$ , and let  $m_1$  be the resulting marking, that is,  $m [t] m_1$ . Then  $h(m_1)$  is well-defined and  $h(m) [h(t)] h(m_1)$ .*

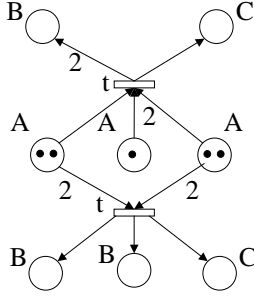

Figure 2: Graphical representation of a homomorphism of nets

**Proof.** According to the firing rule, we have  $m_1 = m - \text{Pre}(t) + \text{Post}(t)$ . The assumption that  $h$  is a homomorphism implies that, for each place  $p'$  of  $N'$ , the sums  $\sum_{p \in h^{-1}(p')} \text{Pre}(p, t)$  and  $\sum_{p \in h^{-1}(p')} \text{Post}(p, t)$  are well-defined. Similarly, stating that  $h(m)$  is well-defined implies that each sum  $\sum_{p \in h^{-1}(p')} m(p)$  is well-defined. It follows that

$$h(m_1)(p') = \sum_{p \in h^{-1}(p')} m_1(p) = \sum_{p \in h^{-1}(p')} (m(p) - \text{Pre}(p, t) + \text{Post}(p, t))$$

is well-defined, and is equal to

$$h(m_1)(p') = h(m)(p') - \text{Pre}'(p', h(t)) + \text{Post}'(p', h(t)).$$

That is,  $h(m) [h(t)] h(m_1)$ . □

Proposition 2.5 can be extended by induction to sequences of transitions. This yields immediately the following corollary.

**Corollary 2.6** *Let  $N$  and  $N'$  be Petri nets and let  $h: N \rightarrow N'$  be a homomorphism. Then  $h(\text{Reach}(N)) \subseteq \text{Reach}(N')$ . Moreover, if  $N'$  is safe, then  $N$  is safe.*

**Example 2.7** Figure 2 shows both a net, say,  $N_1$  (with 2 transitions and 8 places), and a homomorphism from this net to the net  $N_2$  from Example 2.1. The values labelling the nodes are the images by the homomorphism. Note that the converse of Proposition 2.5 does not hold: one of the transitions  $t$  of  $N_1$  is not enabled while its image in  $N_2$  is enabled. □



## 2.4 Subnets of nets

Let  $N = (P, T, \text{Pre}, \text{Post}, m_0)$  and  $N' = (P', T', \text{Pre}', \text{Post}', m'_0)$  be nets. We say that  $N'$  is a (*full*) *subnet* of  $N$ , and we write  $N' \sqsubseteq N$ , if  $P' \subseteq P$ ,  $T' \subseteq T$ ,  $m_0 = m'_0$  and for each transition  $t$  of  $N'$ ,  $\text{Pre}(t) = \text{Pre}'(t)$  and  $\text{Post}(t) = \text{Post}'(t)$ .

Observe that this definition is different from the sole requirement that  $P' \cup T' \subseteq P \cup T$  and  $\text{Pre}'$ ,  $\text{Post}'$  and  $m'_0$  are the restrictions of  $\text{Pre}$ ,  $\text{Post}$  and  $m_0$  to the places and transitions of  $N'$ : consider for instance the case where  $N$  and  $N'$  have a single transition  $t$ ,  $N'$  has places  $p'$  and  $q'$ , and  $N$  has places  $p$ ,  $q$ ,  $p'$  and  $q'$ ,  $m_0 = m'_0 = p'$ ,  $\text{Pre}'(t) = p$ ,  $\text{Pre}(t) = p + p'$ ,  $\text{Post}'(t) = q$ ,  $\text{Post}(t) = q + q'$ .

Assuming that the isolated places, if there are any, are in the initial marking, a subnet  $N'$  of a net  $N$  is entirely determined by the set  $T'$  of its transitions: indeed, we have necessarily  $P' = \bar{m}_0 \cup \bigcup_{t \in T'} (\bullet t \cup t \bullet)$  and the pre- and post-conditions of the transitions of  $N'$  are the same as in  $N$ . Moreover, every subset of transitions of  $N$  gives rise to a subnet of  $N$ .

If  $N$  is an acyclic net, we say that a subnet  $N'$  is a *prefix* of  $N$  if  $P' \cup T'$  is an  $\leq$ -order ideal of  $P \cup T$ . We note the following simple observations.

**Lemma 2.8** *Let  $N$  and  $N'$  be Petri nets.*

1.  *$N'$  is isomorphic to a subnet of  $N$  if and only if there exists an injective net homomorphism from  $N'$  into  $N$ .*
2. *The subnets of  $N$  form a complete lattice.*
3. *If  $N$  is acyclic, then every subnet of  $N$  is acyclic.*

**Proof.** The first and third statements are immediate. The second statement is a consequence of the above remark, according to which the subnets of  $N$  are completely determined by the transitions and the isolated, non-initially marked places they contain.  $\square$

## 3 Occurrence nets

A net  $N$  is an *occurrence net* if, for each place  $p \in P$ ,

- if  $m_0(p) > 0$ , then  $p$  is an initial place ( $\bullet p = \emptyset$ );
- if  $m_0(p) = 0$ , then  $p$  receives its inputs from a single transition ( $|\bullet p| = 1$ ), denoted by  $\bullet p$ ;
- $N$  is quasi-live (every transition is enabled by some reachable marking).

Occurrence nets were introduced by Nielsen, Plotkin and Winskel [7] in the safe case. Our definition is somewhat simpler, and it makes no assumption of safeness or finiteness.

### 3.1 Elementary properties of occurrence nets

**Proposition 3.1** *Let  $N = (P, T, \text{Pre}, \text{Post}, m_0)$  be an occurrence net. Then  $N$  is acyclic and every vertex of the graph  $N$  is preceded by a finite number of transitions. That is, if  $x \in P \cup T$ , then  ${}^*x \cap T$  is finite.*

**Proof.** As the graph (underlying)  $N$  is bipartite, if  $N$  has a cycle, then there exists a sequence of places  $p_0, p_1, \dots, p_{n-1}$  and a sequence of transitions  $t_0, t_1, \dots, t_{n-1}$  such that  $\bullet p_i = t_i$  and  $t_i \in p_{i-1} \bullet$  for  $i = 0, \dots, n$  (where  $i$  is taken modulo  $n$ ). The value at  $p_i$  of a marking of  $N$  can be modified only by firing transition  $t_i$ , and transition  $t_i$  is enabled by a marking  $m$  only if  $m(p_{i-1}) \neq 0$ . Finally, as none of the places  $p_i$  is an initial place, the initial marking  $m_0$  is 0 on each  $p_i$ : it is now immediately verified, by induction on the length of a firing sequence, that no reachable marking enables any of the transitions  $t_i$ , thus contradicting the assumption that  $N$  is quasi-live.

Thus  $N$  is acyclic. In particular, the set of vertices of the graph  $N$  is partially ordered by the relation  $\xrightarrow{*}$ .

Let  $p \in P$  be a place such that  ${}^*p \neq \emptyset$ : then  ${}^*p \cap T = {}^*(\bullet p) \cap T$  by definition of an occurrence net. We now consider the set  ${}^*t$ , for some transition  $t \in T$ . Observe that if  $t' \in T$  and  $p \in P$  are such that  $t' \rightarrow p \rightarrow t$  in  $N$ , then  $t' = \bullet p$  and  $t$  can be fired only after  $t'$  was fired. This remark is extended by induction to show that if  $t'$  is a transition and  $t' \xrightarrow{\pm} t$ , then  $t'$  must be fired before  $t$  can be fired. As an occurrence net is quasi-live, that is, every transition can appear in a finite sequence of transitions enabled by the initial marking, it follows that the set of transitions in  ${}^*t$  is finite.  $\square$

We note the following property of subnets of occurrence nets. We say that a subnet  $N'$  of a net  $N$  is a *prefix* of  $N$  if  $P' \cup T'$  is an order ideal of  $P \cup T$ .

**Lemma 3.2** *Let  $N$  be an occurrence net and let  $N'$  be a subnet of  $N$ . Then  $N'$  is an occurrence net if and only if  $N'$  is a prefix of  $N$ .*

**Proof.** It is immediate that a prefix of an occurrence net is an occurrence net. Conversely, suppose that  $N' \sqsubseteq N$ . Then  $\text{Pre}(t) = \text{Pre}'(t)$  for each transition  $t$  of  $N'$ . In particular, if  $t$  is a transition of  $N'$  and  $p \rightarrow t$  in  $N$ , then  $p \in P'$ .

If in addition  $N'$  is an occurrence net, consider a place  $p$  of  $N'$ . If  $t \rightarrow p$  in  $N$ , then  $m_0(p) = 0$ . If  $t$  is not in  $N'$ , then  $\bullet p = \emptyset$  in  $N'$ , so that  $m'_0(p) > 0$ , contradicting the equality  $m_0 = m'_0$ . Thus  $t$  is in  $N'$  and  $N'$  is a prefix of  $N$ .  $\square$

For occurrence nets, the distinction between safeness and weak safeness vanishes (see Lemma 2.2).

**Proposition 3.3** *Let  $N$  be an occurrence net. Then  $N$  is safe if and only if  $N$  is weakly safe.*

**Proof.** In view of Lemma 2.2, it suffices to show that if the occurrence net  $N$  is weakly safe, then it is safe. Let us now assume that  $N$  is weakly safe and consider a marking  $m$  of  $N$ , reached after firing a sequence of transitions  $t_1 t_2 \dots t_n$  from the initial marking  $m_0$ . We choose this sequence to be of minimal length, so that it is increasing (Lemma 2.3 and Proposition 3.1).

For  $1 \leq i \leq n$ , let  $m_i$  be the marking reached after firing  $t_1 \dots t_i$ , that is,  $m_0 [t_1 \dots t_i] m_i$  and  $m_n = m$ . In particular  $m_i = m_{i-1} - \text{Pre}(t_i) + \text{Post}(t_i)$  for each  $i$ .

We verify by induction on  $i$  that for each place  $p$  such that  $m_i(p) > 0$ , then either  $p$  is an initial place and  $m_i(p) = m_0(p)$ , or  $\bullet p = t_j$  for some (unique)  $j \leq i$  and  $m_i(p) = m_j(p) = \text{Post}(p, t_j)$ . Note that this implies that the marking  $m_i$  is safe, since  $m_0$  is safe and  $N$  is elementary. Thus this verification will complete the proof of the proposition.

This assertion is trivial if  $i = 0$ , so we now assume that it is true for some  $i < n$  and we consider a place  $p$  such that  $m_{i+1}(p) > 0$ . If  $\text{Pre}(p, t_{i+1}) = \text{Post}(p, t_{i+1}) = 0$ , then  $m_{i+1}(p) = m_i(p)$  and we are done.

If  $\text{Pre}(p, t_{i+1}) \neq 0$ , then  $\text{Post}(p, t_{i+1}) = 0$  by acyclicity and  $m_{i+1}(p) = m_i(p) - \text{Pre}(p, t_{i+1})$ . Since  $m_i$  is safe and  $N$  is elementary, it follows that  $m_{i+1}(p) \leq 0$ , a contradiction.

Finally, if  $\text{Post}(p, t_{i+1}) \neq 0$ , then  $\bullet p = t_{i+1}$  and  $m_{i+1}(p) = m_i(p) + \text{Post}(p, t_{i+1})$ . If  $m_i(p) > 0$ , then the induction hypothesis implies that  $\bullet p = t_j$  for some  $j \leq i$ , so  $t_{i+1} = t_j$ , contradicting the minimality of the firing sequence. Thus  $m_i(p) = 0$  and  $m_{i+1}(p) = \text{Post}(p, t_{i+1})$ , which completes the induction.  $\square$

### 3.2 Configuration

Let  $N$  be a Petri net. The characteristic vector of a firable sequence of transitions is called a *configuration* of  $N$ .

It is not true that, even in an occurrence net, a configuration arises from a unique firable sequence: suppose  $P = \{p_1, \dots, p_4\}$ ,  $T = \{t_1, t_2\}$ ,  $m_0 = p_1 + p_2$ ,  $\text{Pre} = (p_1, t_1) + (p_2, t_2)$  and  $\text{Post} = (p_3, t_1) + (p_4, t_2)$ . Then  $t_1 t_2$  and  $t_2 t_1$  are distinct firable sequences yielding the same configuration. More generally, transitions with disjoint pre-conditions can be fired in any order.

It follows however immediately from the extended firing rule that if two firable sequences induce the same configuration  $\varphi$ , then they both lead to the same marking, denoted by  $\text{Cut}(\varphi)$ . Somewhat abusing definitions, we say that  $\text{Cut}(\varphi)$  is the marking reached after firing the vector (or the configuration)  $\varphi$ .

Configurations of acyclic nets are characterized as follows ([6] for the case of finite nets).

**Proposition 3.4** *Let  $N$  be a Petri net and let  $\varphi$  be a multiset over  $T$ . If  $\varphi$  is a configuration, then the support of  $\varphi$  is finite and, for each place  $p \in P$ , we*

have

$$m_0(p) - \sum_{t \in T} \text{Pre}(p, t) \cdot \varphi(t) + \sum_{t \in T} \text{Post}(p, t) \cdot \varphi(t) \geq 0. \quad (1)$$

If  $N$  is acyclic and  $\varphi$  is a finite support multiset over  $T$  satisfying Equation (1), then  $\varphi$  is a configuration.

**Proof.** If  $\varphi$  is a configuration of the Petri net  $N$ , then the support of  $\varphi$  is trivially finite, and for each place  $p$ ,  $\text{Cut}(\varphi)(p) \geq 0$ : that is exactly the statement in Equation (1).

We now assume that  $N$  is acyclic,  $\varphi$  has finite support and Equation (1) holds for each place  $p$ . We proceed by induction on the value of  $\sum_{t \in T} \varphi(t)$ . The empty multiset is certainly a configuration, since it is the sum of the terms of the empty sequence of transitions. Now we assume that  $\varphi \neq 0$ . The relation  $\xrightarrow{*}$  is a partial order by assumption, and we consider a transition  $s$  maximal in the support of  $\varphi$  and the multiset  $\psi$  such that  $\psi + s = \varphi$ . Of course,  $\psi$  has finite support.

Let  $m_\psi(p) = m_0(p) - \sum_{t \in T} \text{Pre}(p, t) \cdot \psi(t) + \sum_{t \in T} \text{Post}(p, t) \cdot \psi(t)$ . Then Equation (1) states that

$$m_\psi(p) - \text{Pre}(p, s) + \text{Post}(p, s) \geq 0.$$

We want to show that  $m_\psi(p) \geq 0$  for each place  $p$ . If  $\text{Post}(p, s) = 0$ , then  $m_\psi(p) \geq \text{Pre}(p, s) \geq 0$ . If  $\text{Post}(p, s) \neq 0$ , then  $s = \bullet p$ , and since  $s$  is maximal in the support of  $\varphi$ ,  $\text{Pre}(p, t) = 0$  for each transition  $t$  in the support of  $\varphi$ . In particular,

$$m_\psi(p) = m_0(p) + \text{Post}(p, s) \cdot \psi(s) \geq m_0(p) \geq 0.$$

We can now use the induction hypothesis to see that  $\psi$  is a configuration – and hence,  $m_\psi = \text{Cut}(\psi)$ . We already noticed that if  $\text{Post}(p, s) = 0$ , then  $m_\psi(p) \geq \text{Pre}(p, s)$ . Moreover, if  $\text{Post}(p, s) \neq 0$ , then  $\text{Pre}(p, s) = 0$  by acyclicity and again, we have  $m_\psi(p) \geq \text{Pre}(p, s)$ . Thus the transition  $s$  is enabled by the marking  $\text{Cut}(\psi)$  and  $\varphi = \psi + s$  is a configuration.  $\square$

In view of the specificities of occurrence nets, Proposition 3.4 yields the following corollary.

**Corollary 3.5** *Let  $N$  be an occurrence net and let  $\varphi$  be a multiset over  $T$ . Then  $\varphi$  is a configuration of  $N$  if and only if  $\varphi$  has finite support and for each place  $p \in P$ , we have*

$$\begin{aligned} m_0(p) &\geq \sum_{t \in T} \text{Pre}(p, t) \cdot \varphi(t) && \text{if } m_0(p) > 0, \\ \text{Post}(p, \bullet p) \cdot \varphi(\bullet p) &\geq \sum_{t \in T} \text{Pre}(p, t) \cdot \varphi(t) && \text{otherwise.} \end{aligned}$$

We also note that, as in the safe case, each reachable marking of an occurrence net is reached after firing a uniquely determined configuration.

**Proposition 3.6** *Let  $N$  be an occurrence net such that  $t^\bullet \neq \emptyset$  for each transition  $t$ , and let  $m$  be a reachable marking. Then there exists a unique configuration  $\varphi$  of  $N$  such that  $m = \text{Cut}(\varphi)$ .*

**Proof.** We proceed by induction on the maximal length  $r$  of a path in the graph  $N$  from an initial place to a place with non-zero  $m$ -marking. Since  $t^\bullet \neq \emptyset$  for each transition  $t$ , the firing of any transition leads to a marking which is non-zero on some non-initial place. Thus, if  $r = 0$ , then  $m = m_0$  and the result is trivial: by acyclicity,  $m$  can be reached only if we do not fire any transitions.

In the general case, let  $\varphi$  be a configuration such that  $m = \text{Cut}(\varphi)$ , and let  $Q$  be the set of maximal non-initial places with non-zero  $m$ -marking. Then  ${}^\bullet Q$  is the set of maximal transitions  $t$  such that  $\varphi(t) > 0$  and in particular,  ${}^\bullet Q$  is finite and  $m(q) = \text{Post}(q, {}^\bullet q)\varphi({}^\bullet q)$  for each  $q \in Q$ . Thus the maximal elements of the support of  $\varphi$  and the value of  $\varphi$  on these elements are uniquely determined by  $m$ . Moreover, the maximality of the  ${}^\bullet q$  ( $q \in Q$ ) in the support of  $\varphi$  implies that any firable sequence  $\sigma$  whose characteristic vector is equal to  $\varphi$  can be rearranged into a firable sequence of the form  $\sigma'\sigma''$  where  $\sigma''$  contains all the occurrences of the transitions  ${}^\bullet q$  ( $q \in Q$ ).

Now let  $\varphi'$  be the characteristic vector of  $\sigma'$  and let

$$m' = m + \sum_{t \in {}^\bullet Q} \text{Pre}(t)\varphi(t) - \sum_{t \in {}^\bullet Q} \text{Post}(t)\varphi(t).$$

Then  $m \llbracket \sigma' \rrbracket m'$ , that is,  $m' = \text{Cut}(\varphi')$ . We note that  $m'$  is uniquely determined by  $m$  and that it is a reachable marking. Moreover, if  $p$  is a maximal non-initial place such that  $m'(p) > 0$ , then  $p < q$  for some  $q \in Q$ . Thus, by induction,  $\varphi'$  is uniquely determined by  $m'$  and hence, by  $m$ . Since  $\varphi = \varphi' + \sum_{t \in {}^\bullet Q} \varphi(t)t$ , this concludes the proof.  $\square$

**Remark 3.7** The same uniqueness result holds (with the same proof) for any acyclic net such that  $t^\bullet \neq \emptyset$  for each transition  $t$  and  $|{}^\bullet p| \leq 1$  for each place  $p$ .  $\square$

## 4 Branching processes and unfoldings of a net

We now discuss the branching processes and the unfoldings of a net [2], within the framework developed in this paper. Bowing to tradition, occurrence nets in branching processes will be usually be written  $S = (B, E, \text{In}, \text{Out}, q_0)$ , their transitions will be called *events* and their places will be called *conditions*.

## 4.1 Branching processes

A *branching process* of a net  $N$  is a pair  $(S, h)$  consisting of an occurrence net  $S = (B, E, \text{In}, \text{Out}, q_0)$  and a homomorphism  $h: S \rightarrow N$  satisfying a guarded form of injectivity: whenever  $e$  and  $e'$  are events of  $S$ ,

$$\text{if } \text{In}(e) = \text{In}(e') \text{ and } h(e) = h(e') \text{ then } e = e'.$$

The branching process  $(S, h)$  is called *safe* if  $S$  is safe. We note the following technical property of safe branching processes.

**Lemma 4.1** *Let  $(S, h)$  be a safe branching process of a net  $N$ . Then no spontaneous non-isolated transition of  $N$  can occur in the range of  $h$ .*

**Proof.** Let  $t$  be a spontaneous and non-isolated transition of  $N$ , and suppose that  $t = h(e)$  for some event  $e$  of  $S$ . Then  $\text{In}(e) = 0$  and  $\text{Out}(e) \neq 0$  by Lemma 2.4, so  $e$  is spontaneous and not isolated, which implies immediately that  $S$  is not safe. Thus  $t$  is not in the range of  $h$ .  $\square$

We now introduce a new property of branching processes. We say that the branching process  $(S, h)$  is *true* if  $h$  is one-to-one on  $\bar{q}_0$ , the support of the initial marking of  $S$ , and on the post-set  $e^\bullet$  of each event  $e$  of  $S$ . Our first observation states that for safe nets, all branching processes are both safe and true.

**Lemma 4.2** *Every branching process of a weakly safe net is safe and true.*

**Proof.** Let  $N$  be a weakly safe net and let  $(S, h)$  be a branching process of  $N$ . By Lemma 2.4, we know that  $S$  is weakly safe and  $(S, h)$  is true. Since  $S$  is an occurrence net, it follows from Proposition 3.3 that  $S$  is safe, which concludes the proof.  $\square$

Let  $(S, h)$  and  $(S', h')$  be branching processes of  $N$  and let  $g: S \rightarrow S'$  be a homomorphism of nets. We say that  $g$  is a *homomorphism of branching processes* — written  $g: (S, h) \rightarrow (S', h')$  — if  $h = h' \circ g$ , see Figure 3.

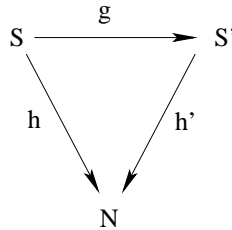

Figure 3:  $g: (S, h) \rightarrow (S', h')$  is a homomorphism of branching processes

**Lemma 4.3** *Let  $S$  and  $S'$  be occurrence nets,  $h: S \rightarrow N$ ,  $h': S' \rightarrow N$  and  $g: S \rightarrow S'$  be homomorphisms such that  $h = h' \circ g$  and assume that  $(S', h')$  is a branching process of  $N$ .*

1.  *$(S, h)$  is a branching process of  $N$  if and only if  $(S, g)$  is a branching process of  $S'$ .*
2. *If  $(S', h')$  is true, then  $(S, h)$  is a true branching process of  $N$  if and only if  $(S, g)$  is a true branching process of  $S'$ .*
3. *If  $(S', h')$  is true, then  $g$  is the only net homomorphism from  $S$  to  $S'$ .*
4. *If  $(S, h)$  and  $(S', h')$  are true branching processes, then  $g$  is injective.*

**Proof.** Let  $S = (B, E, \text{In}, \text{Out}, q_0)$ ,  $S' = (B', E', \text{In}', \text{Out}', q'_0)$  and let  $e, e'$  be events of  $S$  such that  $\text{In}(e) = \text{In}(e')$ . We first assume that  $(S, h)$  is a branching process of  $N$  and that  $g(e) = g(e')$ . Then  $h(e) = h'(g(e))$  and  $h(e') = h'(g(e'))$  are equal: as  $(S, h)$  is a branching process, it follows that  $e = e'$ . Thus  $(S, g)$  is a branching process.

Conversely, suppose that  $(S, g)$  is a branching process and  $h(e) = h(e')$ . Since  $g$  is a homomorphism, we have  $\text{In}'(g(e)) = g(\text{In}(e))$  and  $\text{In}'(g(e')) = g(\text{In}(e'))$ , so that  $\text{In}'(g(e)) = \text{In}'(g(e'))$ . Moreover,  $h'(g(e)) = h(e) = h(e') = h'(g(e'))$ : since  $(S', h')$  is a branching process, we have  $g(e) = g(e')$ , and since  $(S, g)$  is a branching process as well, we have  $e = e'$ , which concludes the proof of Property (1).

The verification of the preservation of true branching processes, that is, of Property (2), is elementary.

We now turn to Property (3): let us assume that  $(S', h')$  is true and that  $g': S \rightarrow S'$  is a homomorphism such that  $h = h' \circ g'$ . Let  $b \in \overline{q_0}$ : then  $h(b) = h'(g'(b)) = h'(g(b))$  with  $g(b), g'(b) \in \overline{q'_0}$ . Since  $h'$  is injective on  $\overline{q'_0}$ , it follows that  $g(b) = g'(b)$ . Now suppose that  $I$  is a subnet of  $S$  and  $g$  and  $g'$  coincide on  $I$ . Let  $e$  be an event of  $S$  such that  $\bullet e \subseteq I$ . Then  $\text{In}'(g(e)) = g(\text{In}(e)) = g'(\text{In}(e)) = \text{In}'(g'(e))$ . In addition, we have  $h'(g(e)) = h(e) = h'(g'(e))$ : it follows that  $g(e) = g'(e)$  since  $(S', h')$  is a branching process. Moreover, if  $b \in e^\bullet$ , then  $h'(g(b)) = h(b) = h'(g'(b))$ , and since  $h'$  is injective on  $g(e)^\bullet$ , we have  $g(b) = g'(b)$ . Thus  $I \cup \{e\} \cup e^\bullet$  is a subnet of  $S$  on which  $g$  and  $g'$  coincide. The hypothesis of quasi-liveness made on  $(S, h)$  now suffices to conclude that  $g = g'$ .

Finally, we verify Property (4): let us assume that both  $(S, h)$  and  $(S', h')$  are true branching processes. Let  $b_1 \in \overline{q_0}$  and let  $b_2$  be a condition of  $S$  such that  $b' = g(b_1) = g(b_2)$ . Then  $b' \in \overline{q'_0}$ . It follows that  $b_2 \in \overline{q_0}$ : if it is not the case, then  $S$  has an event  $e = \bullet b_2$  and  $b' = g(b_2) \in g(e)^\bullet$ , a contradiction. By Property (2),  $(S, g)$  is true, so  $g$  is injective on  $\overline{q_0}$  and it is now immediate that  $b_1 = b_2$ .

Let  $I$  be a subnet of  $S$  such that  $g^{-1}(g(I)) = I$  and  $g$  is injective on  $I$ . Let  $e_1, e_2$  be events of  $S$  such that  $\bullet e_1 \subseteq I$  and  $g(e_1) = g(e_2) = e'$ . Since  $\text{In}'(e') = g(\text{In}(e_1)) = g(\text{In}(e_2))$ , the hypothesis on  $I$  implies that  $\bullet e_2 \subseteq I$ , and  $\text{In}(e_1) = \text{In}(e_2)$ . Since  $(S, g)$  is a true branching process of  $S'$  (by Property (2)), it follows that  $e_1 = e_2$ .

Now if  $b_1, b_2$  are conditions of  $S$  such that  $b_1 \in e^\bullet$  and  $g(b_1) = g(b_2) = b'$ , then  $b_2 \notin \overline{q'_0}$  (by the argument developed above). In particular, we have  $g(e_1) = \bullet b' = g(\bullet b_2)$  and, by hypothesis on  $I$ , we find that  $\bullet b_2 \in I$  and  $e_1 = \bullet b_2$ . But  $g$  is injective on  $e_1^\bullet$ , which contains both  $b_1$  and  $b_2$ , so  $b_1 = b_2$ . As in the proof of Property (3), using the quasi-liveness of  $S$ , we conclude that  $g$  is an injective homomorphism.  $\square$

## 4.2 Unfoldings of a net

Let  $(S, h)$  and  $(S', h')$  be branching processes of a net  $N$ . As in [2], we say that  $(S, h) \sqsubseteq (S', h')$  if  $S$  is a subnet of  $S'$  (that is,  $S \subseteq S'$ ) and  $h$  is the restriction of  $h'$  to  $S$ . Equivalently,  $(S, h) \sqsubseteq (S', h')$  if there exists an injective homomorphism of branching processes from  $(S, h)$  into  $(S', h')$ .

Now, a  $\sqsubseteq$ -maximal branching process of  $N$  is called an *unfolding* of  $N$ .

We say that a marking  $v$  of a net is *covered* if there exists a reachable marking  $m$  such that  $v \leq m$ . The following characterization of unfoldings plays a major rôle in the sequel.

**Proposition 4.4** *A branching process  $(S, h)$  of a net  $N$  is an unfolding if and only if the following property holds:*

( $\dagger$ ) *if  $t$  is a transition of  $N$  such that  $\text{Pre}(t) = h(v)$  for some marking  $v$  covered in  $S$ , then there exists an event  $e$  of  $S$  such that  $h(e) = t$  and  $\text{In}(e) = v$ .*

**Proof.** Let us first assume that  $(S, h)$  and  $(S', h')$  are branching processes of  $N$ ,  $(S, h)$  satisfies Property ( $\dagger$ ), and  $(S, h) \sqsubseteq (S', h')$ . We first verify that if  $S$  and  $S'$  contain the same events, then they also contain the same conditions, and hence they are equal. Indeed, the assumption that  $S \subseteq S'$  implies that  $S$  and  $S'$  have the same initial conditions and that, for each event  $e$  of  $S'$ ,  $S$  contains all the conditions of  $S'$  which are in  $\bullet e$  or  $e^\bullet$ ; finally the definition of occurrence nets implies that all the conditions of  $S'$  are either initial or in the postset of an event.

Thus if  $S \neq S'$ , there is an event  $e'$  of  $S'$  not in  $S$ . In the acyclic net  $S'$ , we can choose  $e'$  to be  $\leq$ -minimal.

Since  $S'$  is quasi-live, there exists a firable sequence of events  $\sigma$  such that the sequence  $\sigma e'$  is firable; in addition,  $\sigma$  can be assumed to consist only of events that are  $\leq$ -less than  $e'$ . By minimality of  $e'$ ,  $\sigma$  is also a firable sequence



of  $S$  and in particular, the conditions in  $\text{In}'(e')$  are in  $S$ . If  $v$  is the marking reached after the firing of  $\sigma$  in  $S'$ ,  $m'_0 [\sigma] v$ , then the support of  $v$  is in  $S$  by definition of full subnets, so that  $m_0 [\sigma] v$  in  $S$  as well.

Now,  $\text{Pre}(h'(e')) = h'(\text{In}'(e'))$  and  $\text{In}'(e')$  is covered by the marking  $v$ , which is reachable in  $S$ . By Property  $(\dagger)$ , there exists an event  $e$  of  $S$  such that  $h(e) = h'(e')$  and  $\text{In}(e) = \text{In}'(e')$ . But  $h$  is a restriction of  $h'$ , so  $h'(e) = h'(e')$  and, by definition of a branching process, we get  $e = e'$ , a contradiction. Thus, if  $(S, h)$  satisfies Property  $(\dagger)$ , then  $(S, h)$  is  $\sqsubseteq$ -maximal among the branching processes of  $N$ , that is,  $(S, h)$  is an unfolding of  $N$ .

Conversely, let us assume that  $(S, h)$  does not satisfy Property  $(\dagger)$ , that is, there exists a transition  $t$  of  $N$  which does not lie in  $h(S)$ , such that  $\text{Pre}(t) = h(v)$  for some marking  $v$  of  $S$ , which is covered in  $S$ . Then there exists a firable sequence of  $S$ ,  $\sigma$ , such that  $v \leq \text{Cut}(\sigma)$ . Let us construct a new net  $S'$  by adding to  $S$  one new event, say  $e$ , and a set  $Q$  of new conditions, equipped with a bijection  $j$  onto the support of  $\text{Post}(t)$ . We let  $\text{Out}'(e) = \sum_{q \in Q} \text{Post}(j(q), t)q$ ,  $\text{In}'(e) = v$ , and for each event  $f$  of  $S$ ,  $\text{In}'(f) = \text{In}(f)$  and  $\text{Out}'(f) = \text{Out}(f)$ . We also consider the extension  $h'$  of the homomorphism  $h$  given by  $h'(e) = t$  and  $h'(q) = j(q)$  for each  $q \in Q$ . In order to conclude, we need to verify that  $(S', h')$  is a branching process of  $N$  and  $(S, h) \sqsubseteq (S', h')$ , which is immediate. This shows that  $(S, h)$  is not  $\sqsubseteq$ -maximal, and hence not an unfolding.  $\square$

The proof of Proposition 4.4 yields the following corollary.

**Corollary 4.5** *A true (resp. safe) branching process of a net  $N$  is an unfolding if and only if it is  $\sqsubseteq$ -maximal among the true (resp. safe) branching processes of  $N$ .*

**Proof.** If the true (resp. safe) branching process  $(S, h)$  is an unfolding of  $N$ , then it is obviously  $\sqsubseteq$ -maximal among the true (resp. safe) branching processes of  $N$ . To verify the converse, suppose that  $(S, h)$  is true (resp. safe) and enjoys that relative maximality condition. If  $(S, h)$  is not an unfolding, we can construct a branching process  $(S', h')$  as in the last paragraph of the proof of Proposition 4.4. But it is easily verified that  $(S', h')$  is true if  $(S, h)$  is. It is also clear that  $S'$  is weakly safe if  $S$  is, and in view of Proposition 3.3, this means that  $S'$  is safe if  $S$  is. Thus, if  $(S, h)$  is maximal relative to the true (resp. safe) branching processes of  $N$ , then it is an unfolding.  $\square$

We also note the following corollary of Proposition 4.4, which expresses the fact that unfoldings simulate all the firable sequences of a net.

**Corollary 4.6** *Let  $(S, h)$  be an unfolding of the net  $N$ . If  $\varphi$  is a firable sequence of  $N$ , then there exists a firable sequence  $\psi$  of  $S$  such that  $h(\psi) = \varphi$ .*

**Proof.** Let  $N = (P, T, \text{Pre}, \text{Post}, m_0)$  and  $S = (B, E, \text{In}, \text{Out}, q_0)$ . We first observe the following elementary fact: let  $m$  be a multiset over  $P$  and  $v$  be a multiset over  $B$  such that  $m \leq h(v)$ . Then there exists a multiset  $v'$  over  $B$  such that  $m = h(v')$  and  $v' \leq v$ . Indeed, for each  $p \in P$ , we have  $m(p) \leq h(v)(p) = \sum_{b \in B, h(b)=p} v(b)$ : one can choose, for each  $b \in B$  such that  $h(b) = p$ , a value  $0 \leq v'(b) \leq v(b)$  such that  $m(p) = \sum_{b \in B, h(b)=p} v'(b)$ .

We now proceed by induction on the length  $n$  of  $\varphi$ . If  $n = 0$ , the statement is trivially true. We now assume that  $\varphi = \varphi' t$  and we let  $w$  be the marking such that  $m_0 [\varphi'] w$ . Since  $\varphi$  is firable,  $\text{Pre}(t) \leq w$ . And by induction hypothesis, there exists a firable sequence  $\psi'$  of  $S$  such that  $h(\psi') = \varphi'$ . In particular, if  $q_0 [\psi'] v$ , we have  $w = h(v)$  and hence  $\text{Pre}(t) \leq h(v)$ . As verified above, it follows that  $\text{Pre}(t) = h(v')$  for some multiset  $v' \leq v$ . In particular,  $v'$  is covered in  $S$  and by Proposition 4.4, there exists an event  $e$  of  $S$  such that  $h(e) = t$  and  $\text{In}(e) = v'$ . Therefore, the event  $e$  is enabled by the marking  $v$  and hence the sequence  $\psi = \psi' e$  is firable, which concludes the proof.  $\square$

### 4.3 True unfolding and safe unfolding

The main results of this section, Theorems 4.7 and 4.10, show the existence and the unicity of a true (resp. safe) unfoldings – up to isomorphism in the case of safe unfoldings.

#### 4.3.1 The true case

**Theorem 4.7** *Every net  $N$  has a greatest true branching process, denoted by  $\mathcal{B}_{\text{true}}$ . Moreover,  $\mathcal{B}_{\text{true}}$  is the unique true unfolding of  $N$ .*

**Proof.** Let  $N = (P, T, \text{Pre}, \text{Post}, m_0)$ . We first consider the net  $S_0$ , whose condition set is  $\overline{m}_0$ , with initial marking  $m_0$ , and without any event. Then  $S_0$  is an occurrence net and if  $h_0$  is the identity map on  $\overline{m}_0$ , then  $(S_0, h_0)$  is a true branching process of  $N$ .

Suppose that we have constructed a sequence  $(S_i, h_i)_{i \leq n}$  of true branching processes, such that  $(S_i, h_i) \sqsubseteq (S_j, h_j)$  whenever  $i < j$ . By definition,  $S_i$  is a subnet (and a prefix) of  $S_j$  and  $h_i$  is the restriction to  $S_i$  of  $h_j$ . A new net  $S_{n+1}$  is constructed from  $S_n$  as follows.

For each transition  $t$  of  $N$  and for each marking  $v$  of  $S_n$ , covered in  $S_n$ , such that  $\text{Pre}(t) = h_n(v)$ , and such that  $S_n$  has no event  $e$  with  $h_n(e) = t$  and  $\text{In}_n(e) = v$ , we add to  $S_n$  a new event  $e$ , and a set of conditions  $Q$ , equipped with a bijection  $j$  onto the support of  $\text{Post}(t)$  ( $e$  and the set  $Q$  depend on the choice of  $t$  and  $v$ ). Then we extend the mappings  $\text{In}_n$  and  $\text{Out}_n$  by letting  $\text{In}_{n+1}(e) = v$  and  $\text{Out}_{n+1}(e) = \sum_{q \in Q} \text{Post}(j(q), t)q$  for each new event. We also extend  $h_n$  by letting  $h_{n+1}(e) = t$  for each new event  $e$ , and  $h_{n+1}(q) = j(q)$  for each new condition  $q$ . It is immediate that the resulting net  $S_{n+1}$  is an

occurrence net, that the pair  $(S_{n+1}, h_{n+1})$  is a true branching process of  $N$ , and that  $(S_n, h_n) \sqsubseteq (S_{n+1}, h_{n+1})$ .

Note that  $S_{n+1}$  may not be defined (if no pair  $(t, v)$  as above can be identified in  $S_n$ ), in which case the sequence  $(S_i, h_i)_i$  is finite. In general however, this is an infinite increasing sequence of true branching processes of  $N$ . In any case, let  $S = (B, E, \text{In}, \text{Out}, q_0)$  be the union of the  $S_i$ , that is,  $B = \bigcup_{i \in I} B_i$  and  $E = \bigcup_{i \in I} E_i$ , with  $\text{In}(e) = \text{In}_i(e)$  and  $\text{Out}(e) = \text{Out}_i(e)$  if  $e \in E_i$ . The mappings  $h: B \rightarrow P$  and  $h: E \rightarrow T$  are defined similarly, by letting  $h(x) = h_i(x)$  whenever  $x$  occurs in  $S_i$ . Again, it is easily verified that  $(S, h)$  is a true branching process of  $N$ . We now verify that  $(S, h)$  is an unfolding, using Condition  $(\dagger)$  in Proposition 4.4.

Let  $t$  be a transition of  $N$  such that  $\text{Pre}(t) = h(v)$  for some marking  $v$  covered in  $S$ . Then  $t$  lies in some  $S_n$ , and since each  $S_n$  is a prefix of  $S$ , the marking  $v$  is also covered in  $S_n$  and  $\text{Pre}(t) = h_n(v)$ . By construction, there exists an event  $e$  in  $S_n$  or in  $S_{n+1}$  such that  $h_{n+1}(e) = t$  and  $\text{In}_{n+1}(e) = v$ . In particular  $h(e) = t$  and  $\text{In}(e) = v$ , so Condition  $(\dagger)$  holds and  $(S, h)$  is an unfolding.

To prove uniqueness of the true unfolding, we consider true unfoldings  $(S, h)$  and  $(S', h')$ . By Proposition 4.4, one can verify that  $h$  and  $h'$  are surjective onto  $\bar{m}_0$ , and hence they establish bijections from  $\bar{q}_0$  and  $\bar{q}'_0$  onto  $\bar{m}_0$ . For each condition  $b$  in  $\bar{q}_0$ , we let  $g(b)$  be the unique condition in  $\bar{q}'_0$  such that  $h(b) = h'(g(b))$ . Suppose now that a homomorphism  $g$  has been defined from a prefix of  $(S, h)$  to  $(S', h')$ , and let  $e$  be a  $\leq$ -minimal event of  $S$  which is not in the domain of  $g$ . Since  $S$  is quasi-live, there exists a firable sequence of events  $\sigma e$ , where  $\sigma$  consists only of events that are  $\leq$ -less than  $e$ , and hence are in the domain of  $g$ . In particular,  $\text{In}(e)$  is covered by  $\text{Cut}(\sigma)$ , and the conditions in the support of  $\text{In}(e)$  are in the domain of  $g$ . Consider then the transition  $h(e)$  in  $N$ . Then  $\text{Pre}(h(e)) = h(\text{In}(e)) = h'(g(\text{In}(e)))$  and this marking is covered in  $S'$  by  $g(\sigma)$ . By Condition  $(\dagger)$ , there exists an event  $e'$  of  $S'$  such that  $h'(e') = h(e)$  and  $\text{In}'(e') = g(\text{In}(e))$ . Moreover, by definition of true branching processes,  $h$  and  $h'$  define bijections from  $e^\bullet$  and  $e'^\bullet$  to  $h(e)^\bullet$ . Thus, if we add to the domain of  $g$  the event  $e$  and the conditions in its postset  $e^\bullet$ , we can extend  $g$  to a homomorphism defined on this larger prefix of  $S$ .

Since every condition and event of  $S$  has a finite past (Proposition 3.1) and since such homomorphisms defined on prefixes of  $S$  must coincide on the intersection of their domains (Lemma 4.3), we can define a homomorphism from the branching process  $(S, h)$  to the branching process  $(S', h')$ .

By Lemma 4.3 again, this morphism is injective, so  $(S, h) \sqsubseteq (S', h')$  and the  $\sqsubseteq$ -maximality of unfoldings implies that  $(S, h) = (S', h')$ .  $\square$

We record the following easy but illuminating observation.

**Corollary 4.8** *Each true branching process of a net  $N$  is isomorphic to a single prefix of the true unfolding of  $N$ .*

**Proof.** Since  $\mathcal{B}_{\text{true}}$  is the unique true unfolding of  $N$  (Theorem 4.7), every true branching process  $(S, h)$  of  $N$  is  $\sqsubseteq$ -less than  $\mathcal{B}_{\text{true}}$ , and hence there exists an injective homomorphism  $g: (S, h) \rightarrow \mathcal{B}_{\text{true}}$ . In particular,  $(S, h)$  is isomorphic to its image under  $g$ , which is a prefix of  $\mathcal{B}_{\text{true}}$ . Moreover, Lemma 4.3 shows that this homomorphism is unique, and hence  $(S, h)$  is not isomorphic to any other prefix of  $\mathcal{B}_{\text{true}}$ .  $\square$

The existence of a greatest true branching process can also be used to show the following, more detailed order-theoretic result.

**Proposition 4.9** *The set of true branching processes forms a complete lattice.*

**Proof.** Let  $\mathcal{B}_{\text{true}}$  be the unique true unfolding of  $N$ , and let  $(S_i, h_i)_{i \in I}$  be a family of true branching processes of  $N$ . Then each  $S_i$  can be identified with a subnet of  $\mathcal{B}_{\text{true}}$ . The proof of the announced result thus reduces to verifying that an arbitrary intersection or union of sub-occurrence nets of an occurrence net form an occurrence net.

But Lemma 3.2 shows that a subnet of  $\mathcal{B}_{\text{true}}$  is an occurrence net itself if and only if it is a prefix – and it is immediate that an intersection or a union of prefixes is a prefix.  $\square$

### 4.3.2 The safe case

With a similar proof as Theorem 4.7, we get an analogous result, concerning the existence of a safe unfolding. However, as we shall see, the order-theoretic properties of safe branching processes are less strong than for true branching processes.

**Theorem 4.10** *Suppose that every spontaneous transition of  $N$  is isolated. Then  $N$  has a greatest safe branching process, denoted by  $\mathcal{B}_{\text{safe}}$ . Moreover, up to isomorphism,  $\mathcal{B}_{\text{safe}}$  is the unique safe unfolding of  $N$ .*

**Proof.** The proof follows the same line as that of Theorem 4.7, and we only indicate the differences. As in the proof of Theorem 4.7, the net  $S_0$  has no event, and only initial conditions ; but its condition set is defined by splitting each initial place of  $N$  according to its initial marking. More precisely,  $S_0$  consists of a disjoint union  $\bigcup_{p \in \overline{m_0}} B^p$  where each set  $B^p$  consists of  $m_0(p)$  elements, each with an initial marking equal to 1. The map  $h_0$  sends each condition in  $B^p$  to  $p$ : thus  $(S_0, h_0)$  is a safe branching process of  $N$ .

Again, we assume that we have constructed a finite sequence of safe branching processes  $(S_i, h_i)_{i \leq n}$ , where  $(S_i, h_i) \sqsubseteq (S_j, h_j)$  for each  $i < j$ . If  $t$  and  $v$  are

a transition of  $N$  and a marking of  $S_n$  as in the proof of Theorem 4.7, we construct  $(S_{n+1}, h_{n+1})$  from  $(S_n, h_n)$  as in that proof, with the following difference: the set  $Q$  of conditions that are added to  $S_n$  in relation with the pair  $(t, v)$  is the disjoint union  $\bigcup_{p \in \overline{\text{Post}(t)}} Q^p$  of sets such that  $Q^p$  has  $\text{Post}(t, p)$  elements. Then  $\text{Out}_{n+1}(e) = \sum_{p \in \overline{\text{Post}(t)}} \sum_{q \in Q^p} q$ , and  $h_{n+1}$  maps each condition in  $Q^p$  to the place  $p$ .

It is immediately verified that  $(S_{n+1}, h_{n+1})$  is an elementary branching process of  $N$ . Moreover, by definition of net homomorphisms, the absence of spontaneous non-isolated transitions in  $N$  implies the same property for  $S_{n+1}$ . Thus  $S_{n+1}$  is weakly safe, and by Proposition 3.3,  $S_{n+1}$  is safe. Now, if  $(S, h)$  is defined as in the proof of Theorem 4.7, as the inductive limit of the increasing sequence of safe branching processes  $(S_n, h_n)$ , then  $(S, h)$  is a safe unfolding of  $N$ .

Now consider another safe unfolding  $(S', h')$ . By definition, the initial conditions of  $(S', h')$  are mapped by  $h'$  onto  $\overline{m_0}$ , and since  $S'$  is safe, each  $h'^{-1}(q)$  ( $q \in \overline{m_0}$ ) has  $m(q)$  elements; it follows that we can build an injective homomorphism  $g$  from  $\bigcup_{q \in \overline{m_0}} B^q$ , that is, from  $(S_0, h_0)$  to  $(S', h')$ .

Suppose now that we have constructed an injective homomorphism  $g$  from  $(S_n, h_n)$  to  $(S', h')$ . Let  $F_n$  be the set of events in  $S_{n+1}$  and not in  $S_n$ : by construction, each event  $f \in F_n$  has its pre-condition in  $S_n$ , this pre-condition is reachable in  $S_n$ , and the conditions in  $S_{n+1}$  and not in  $S_n$  are exactly the conditions in the postsets of these events. Now, for each  $f \in F_n$ , Condition  $(\dagger)$  applied to the unfolding  $(S', h')$  yields an event  $f'$  of  $S'$  such that  $h'(f') = h(f)$  and  $\text{In}'(f') = g(\text{In}(f))$ . Since  $(S', h')$  is a branching process,  $f'$  is uniquely determined. Now we have  $h(\text{Out}(f)) = \text{Post}(h(f)) = h'(\text{Out}'(f'))$ , and in a safe occurrence net, each condition in the support of  $\text{Out}(f)$  or  $\text{Out}'(f')$  receives value 1. Thus we can extract a bijection from  $f^\bullet$  to  $f'^\bullet$ , which can be used to extend  $g$  injectively to  $S_{n+1}$ . By induction, we have constructed an injective homomorphism  $g: (S, h) \rightarrow (S', h')$ . It follows that  $(S, h) \sqsubseteq (S', h')$  and the  $\sqsubseteq$ -maximality of unfoldings implies that  $(S, h) = (S', h')$ .  $\square$

**Example 4.11** Consider the net  $N$  represented in Figure 4. The nets  $\beta_1, \dots, \beta_4$  represented in Figure 5 are safe branching processes of  $N$ . Moreover, it is easy to verify that both  $\beta_3$  and  $\beta_4$  are  $\sqsubseteq$ -less than  $\beta_1$  and  $\beta_2$ , and that both are maximal with this property: thus  $\beta_1$  and  $\beta_2$  do not admit a greatest lower bound. Similarly, Figure 6 shows safe branching processes  $\beta_1$  and  $\beta_2$ , and distinct branching processes  $\beta_3$  and  $\beta_4$  which are minimal among the common upper bounds of  $\beta_1$  and  $\beta_2$ . Thus  $\beta_1$  and  $\beta_2$  do not admit a least upper bound.

It is interesting to observe (compare with Corollary 4.8) that in both cases, both  $\beta_1$  and  $\beta_2$  are isomorphic to two distinct subnets of the safe unfolding of  $N$ , represented in Figure 7.  $\square$

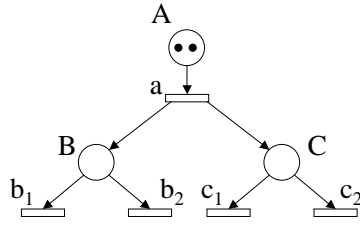

Figure 4: The net  $N$

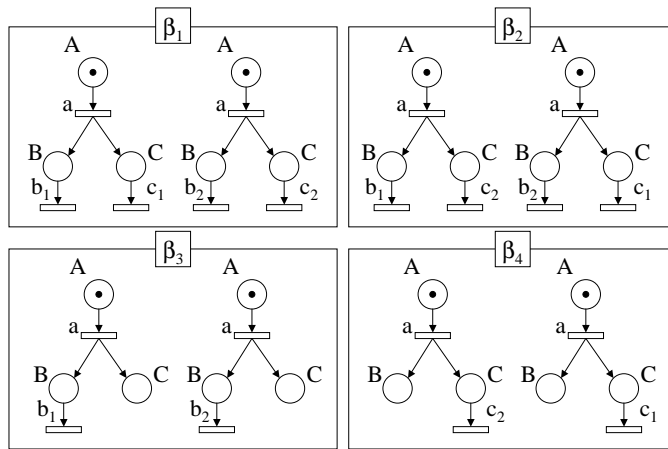

Figure 5: Safe branching processes may not have an inf

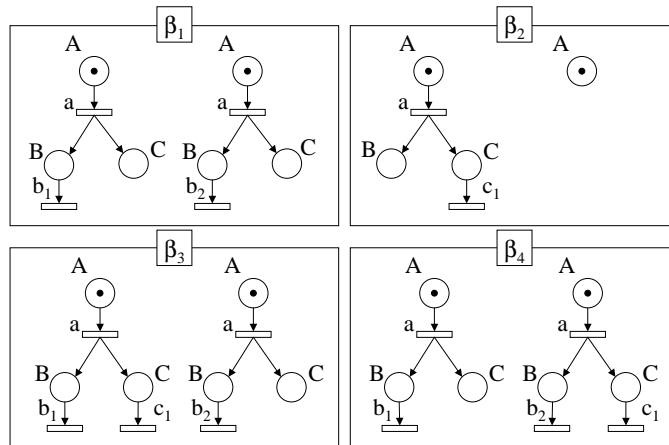

Figure 6: Safe branching processes may not have a sup

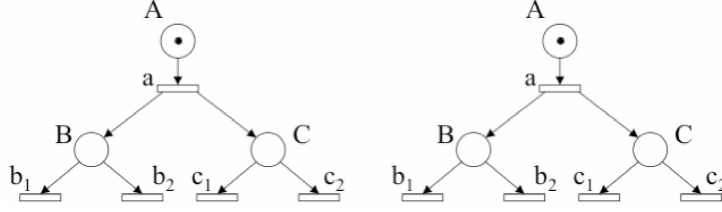

Figure 7: The safe unfolding of  $N$

## 5 Processes and their properties

The notion of process of a net is developed in the literature [7, 2], but it is limited to the case of safe processes. Here we extend the notion, in such a way that the usual *processes* are what we call here *safe processes*.

By definition, a *process of a net*  $N$  is a triple  $\pi = (S, h, \varphi)$  such that  $(S, h)$  is a branching process of  $N$ , and  $\varphi$  is a configuration of  $S$  which covers all its events (that is, every event of  $S$  is in the support of  $\varphi$ ).

We also extend the partial order on branching processes of  $N$ , to its processes. If  $\pi_1 = (S_1, h_1, \varphi_1)$  and  $\pi_2 = (S_2, h_2, \varphi_2)$  are processes of a net  $N$ , we say that  $\pi_1$  and  $\pi_2$  are *equivalent*, written  $\pi_1 \equiv \pi_2$ , if there exists an isomorphism of branching processes  $g$ , from  $(S_1, h_1)$  to  $(S_2, h_2)$ , with  $g(\varphi_1) = \varphi_2$ . We say that  $\pi_1$  is *smaller than*  $\pi_2$ , written  $\pi_1 \sqsubseteq \pi_2$ , if there exists an injective homomorphism from  $(S_1, h_1)$  to  $(S_2, h_2)$  with  $g(\varphi_1) \leq \varphi_2$ . It is immediate that  $\sqsubseteq$  defines a partial order among equivalence classes of processes of  $N$ .

Finally, we say that a process  $\pi = (S, h, \varphi)$  is *true* (resp. *safe*) if the underlying branching process  $(S, h)$  is true (resp. safe). Moreover, if  $(S', h')$  is a branching process of  $N$  and  $(S, h) \sqsubseteq (S', h')$ , we say that  $\pi$  is a *process of the branching process*  $(S', h')$ .

### 5.1 True processes

The above definitions lead directly to the following lemma.

**Lemma 5.1** *Every true (resp. safe) process of a net  $N$  is a process of the true (resp. safe) unfolding of  $N$ .*

**Proof.** The statement follows from Theorems 4.7 and 4.10, since up to isomorphism, every true (resp. safe) branching process of  $N$  is a prefix of its true (resp. safe) unfolding.  $\square$

Lemma 5.1 then leads to the following characterization of the true unfolding of a net.

**Proposition 5.2** *If a branching process of  $N$  contains all the true processes of  $N$ , then it is the true unfolding of  $N$ .*

**Proof.** Let  $(S, h)$  be a branching process containing all the true processes of  $N$ . We first assume that  $(S, h)$  is true. Then the underlying branching processes of the true processes of  $N$  occur as prefixes of  $(S, h)$ , and by Lemma 4.3, each one occurs in a unique way.

Now consider an event  $e$  of  $\mathcal{B}_{\text{true}}$ . The quasi-liveness of occurrence nets ensures that  $e$  occurs in a process  $\pi$  of the branching process  $\mathcal{B}_{\text{true}}$ , and  $\pi$  is necessarily true. Therefore  $\pi$  is a branching process of  $(S, h)$ . Since this holds for each event  $e$ , it follows that  $\mathcal{B}_{\text{true}} \sqsubseteq (S, h)$ . The  $\sqsubseteq$ -maximality of  $\mathcal{B}_{\text{true}}$  allows us to conclude that  $(S, h)$  is the true unfolding of  $N$ .

In the general case, where  $(S, h)$  is not assumed to be true, let  $R$  be the subnet of  $S$  consisting of the initial conditions, of the events  $e$  such that, for each event  $f \leq e$ ,  $h$  is injective on  $f^\bullet$ , and of the pre- and post-conditions of these events. It is immediate that  $R$  is a prefix of  $S$  and then an occurrence net (Lemme 3.2). If  $k$  is the restriction of  $h$  to  $R$  then  $(R, k) \sqsubseteq (S, h)$ . Moreover,  $(R, k)$  is a true branching process, and every true process of  $(S, h)$  is in fact a true process of  $(R, k)$ . It follows from the first part of the proof that  $(R, k) = \mathcal{B}_{\text{true}}$ , and by the  $\sqsubseteq$ -maximality of  $\mathcal{B}_{\text{true}}$ , that  $(S, h) = \mathcal{B}_{\text{true}}$ .  $\square$

We can also show that true processes have valuable order-theoretic properties with respect to the  $\sqsubseteq$ -order.

**Proposition 5.3** *Any family of true processes of a net  $N$  admits a greatest lower bound. If a family of true processes of  $N$  admits a common upper bound, then it has a least upper bound.*

**Proof.** Let  $(\pi_i)_{i \in I}$  be a family of true processes of  $N$ , with  $\pi_i = (S_i, h_i, \varphi_i)$  for each  $i$ . Each  $(S_i, h_i)$  can be viewed in an unambiguous fashion as a prefix of  $\mathcal{B}_{\text{true}}$  (Corollary 4.8), and hence  $\varphi_i$  can be viewed as a configuration of  $\mathcal{B}_{\text{true}}$ . Let  $\varphi = \min_i \varphi_i$ , let  $S$  be the subnet of  $\mathcal{B}_{\text{true}}$  consisting of the initial conditions, the events occurring in  $\varphi$  and their pre- and post-conditions. It is easily verified that  $S$  is a prefix of  $\mathcal{B}_{\text{true}}$ , and if  $h$  is the restriction of (any)  $h_i$  to  $S$ ,  $(S, h)$  is a true branching process of  $N$ . It is also clear that  $(S, h) \sqsubseteq (S_i, h_i)$  and  $\varphi \leq \varphi_i$  for each  $i$ . We want to show that  $(S, h, \varphi) = \min_i \pi_i$ , and for this purpose, it suffices to establish that  $\varphi$  is a configuration. We use the characterization given in Corollary 3.5.

First it is immediate that  $\varphi$  has finite support, since each  $\varphi_i$  does. Moreover, the fact that each  $\varphi_i$  satisfies the inequalities in Corollary 3.5 easily implies that  $\varphi$  does as well. Thus  $(S, h, \varphi) = \min_i \pi_i$ .

The statement concerning upper bounds follows immediately: if the set  $U$  of upper bounds of  $(\pi_i)_{i \in I}$  is non-empty, we claim that  $\inf U$  is the least



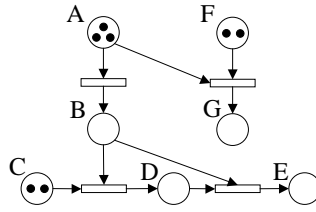

Figure 8: The net  $N$

upper bound of the  $(\pi_i)_{i \in I}$ . To justify this claim, it suffices to verify that  $\inf U$  is indeed an upper bound, that is,  $\inf U \in U$ . This is readily verified, using the description of  $\inf U$  in the first part of the proof, and the fact that the configurations we consider are finite support vectors with positive integer coefficients.  $\square$

**Remark 5.4** Let  $(\pi_i)_{i \in I}$  be a family of true processes of a net  $N$  as in Proposition 5.3. It is not difficult to verify that this family does not have an upper bound if it takes infinitely many values. Now consider the net  $N$  in Figure 4, and consider the true processes determined by the configurations  $a + b_1$ ,  $a + b_2$  and  $a + c_1$ . Any two of these processes have a least upper bound: for instance  $\sup(a + b_1, a + b_2) = 2a + b_1 + b_2$ . Note in particular that the sup of these configurations taken as multisets,  $a + b_1 + b_2$ , is not a configuration. Moreover, the three processes taken together do not admit a common upper bound.  $\square$

## 5.2 Safe processes

In this section, we verify that safe processes do not have the good order-theoretic properties enjoyed by safe processes, described in Propositions 5.2 and 5.3.

Consider the net  $N$  represented in Figure 8. Fig 9 shows all the  $\sqsubseteq$ -maximal safe processes of  $N$ : there are 4 of them, and in particular, no two of these processes admit a sup.

Moreover, Figure 10 shows two distinct safe branching processes of  $N$ , both of which contain all the maximal safe processes. Thus Proposition 5.2 does not hold for safe processes.

Of course, the safe branching processes of Figure 10 also occur in the safe unfolding of  $N$ , shown in Figure 11. This safe unfolding presents large-scale duplication of safe processes.

## 6 Concluding remarks

This paper proposes a general framework for the unfolding of general Petri nets. Traditional occurrence nets are covered by safe unfoldings. The drawbacks of

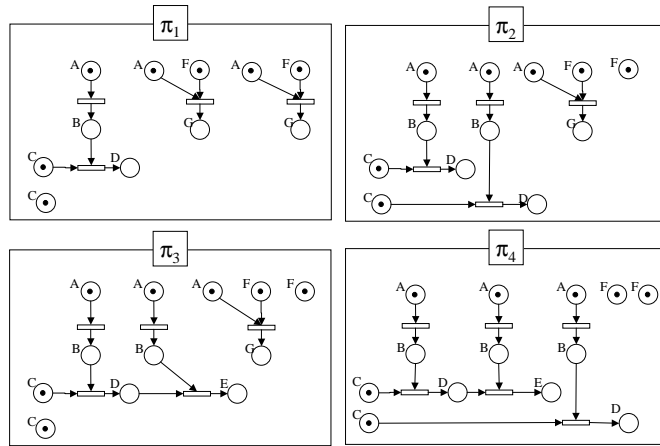

Figure 9: All the maximal safe processes of  $N$

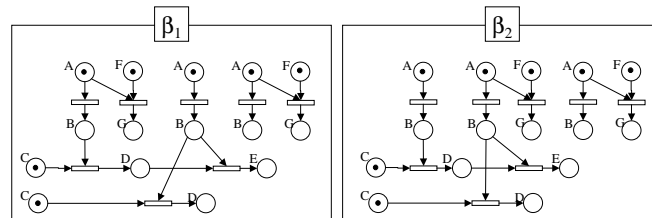

Figure 10: Two safe branching processes containing all the safe processes of  $N$

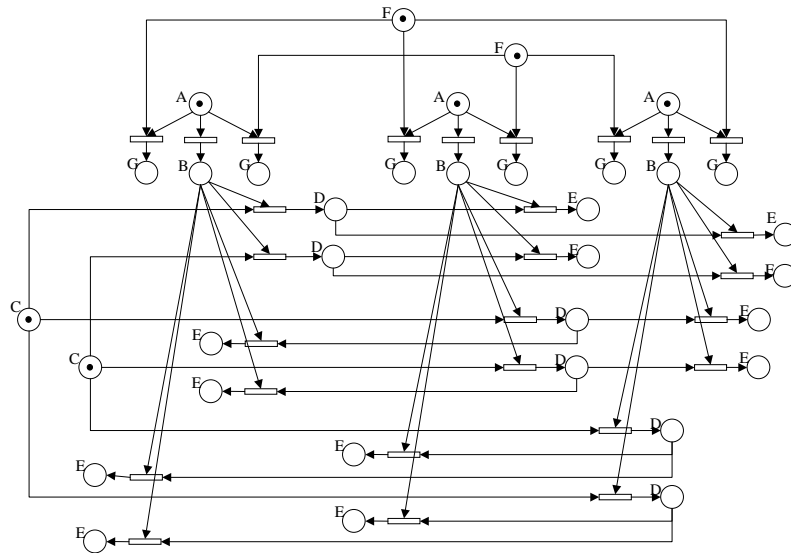

Figure 11: The safe unfolding of  $N$

this approach, when applied to general Petri nets, were identified by Hoogers *et al.* [4], and examples are given in this paper as well, in Sections 4.3.2 and 5.2: even though every net admits a unique safe unfolding, the safe branching processes do not form a lattice, and neither do the safe processes. The root of the problem can be traced to the following fact: a safe process of a net  $N$  may occur in several ways as a process of the safe unfolding of  $N$ .

The essential contribution of our work is the concept of true unfolding of a net. This is an extension of the traditional notion in the following sense: if  $N$  is a safe Petri net, then its safe and its true unfoldings (resp. branching processes, processes) coincide. Moreover, the true processes and the true branching processes of a general net satisfy good order-theoretic properties.

One question not tackled in this paper is the relationship between unfoldings and event structures. Within the framework of general Petri nets, the concept of prime event structure is not adapted to capture the multiset aspects. Two natural questions should be considered: (1) In which cases does the notion of true unfolding make it possible to capture the conflict and causality relations? (2) What is the concept of event structures associated to true unfoldings?

## References

- [1] E. Best and R. Devillers. Sequential and concurrent behaviour in Petri net theory. *Theoretical Computer Science*, 55:87–136, 1987.
- [2] J. Engelfriet. Branching processes of Petri nets. *Acta Informatica*, 28:575–591, 1991.
- [3] S. Haar. Branching processes of general S/T-systems and their properties. *Electronic Notes in Theoretical Computer Science*, 18, 1998.
- [4] P.W. Hoogers, H.C.M. Kleijn, and P.S. Thiagarajan. An event structure semantics for general Petri nets. *Theoretical Computer Science*, 153:129–170, 1996.
- [5] J. Meseguer, U. Montanari, and V. Sassone. On the model of computation of Place/Transition Petri nets. In *Proc. of the 15th Int. Conference on Application and Theory of Petri Nets*, volume 815 of *Lecture Notes in Computer Science*, pages 16–38. Springer Verlag, 1994.
- [6] T. Murata. Petri nets: Properties, analysis, and applications. *Proc. of the IEEE*, 77(4):541–580, 1989.
- [7] M. Nielsen, G. Plotkin, and G. Winskel. Petri nets, events structures and domains, Part I. *Theoretical Computer Science*, 13(1):85–108, 1981.

- [8] Walter Vogler. Executions: A new partial-order semantics of Petri nets. *Theoretical Computer Science*, 91:205–238, 1991.