

Neural Fields, a Cognitive Approach

Attention, Decision & Plasticity

Nicolas P. Rougier

INRIA - University of Bordeaux
Institute of Neurodegenerative Diseases, France

Computational Neuroscience Symposium
Prague, July 18th, 2015

About me

Full-time research scientist at INRIA Bordeaux, the French National Institute for Research in Computer Science and Control.

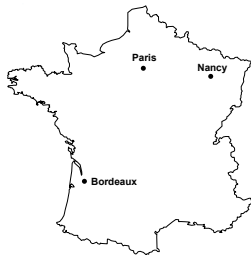

The Mnemosyne project

Major cognitive and behavioral functions emerge from adaptive sensorimotor loops involving the external world, the body and the brain. We study, model and implement such loops and their interactions toward a fully autonomous behavior. With such a systemic approach, we mean that such complex systems can only be truly apprehended as a whole and in natural behavioral situation.

Funding

- INRIA
- CNRS
- University of Bordeaux
- Institute of Neurodegenerative Diseases

What is cognition ?

What are the questions ?

- What are the main forms of cognition ?
- What are the minimal mechanisms ?
- What is/are the right biological levels ?
- How do we identify a satisfactory answer ?
- What is the role of the observer ?



The case of *Caenorhabditis elegans*

Sensory motor behavior

Q. Wen, M.D. Po, E. Hulme, S. Chen, X. Liu, S. Wai Kwok, M. Gershow, A. M. Leifer, V. Butler, C. Fang-Yen, T. Kawano, W.R. Schafer, G. Whitesides, M. Wyart, D.B. Chklovskii, M. Zhen, A.D.T. Samueln, **Proprioceptive Coupling within Motor Neurons Drives C. elegans Forward Locomotion**. *Neuron*, 2012.

Plasticity, learning and memory

H. Sasakura and I. Mori, **Behavioral plasticity, learning, and memory in C. elegans**, *Current Opinion in Neurobiology*, 2013.

Decision making

T.A. Jarrell, Y. Wang, A.E. Bloniarz, C.A. Brittin, M. Xu, J.N. Thomson, D.G. Albertson, D.H. Hall, S.W. Emmons, **The Connectome of a Decision-Making Neural Network**, *Science*, 2012.

What really matters for cognition ?

Some figures

- C.Elegans → 302 neurons
- Mouse → 71,000,000 neurons
- Rat → 200,000,000 neurons
- Macaque → 6,376,000,000 neurons
- Human → 86,000,000,000 neurons

Some wrong assumptions

- Body size matters
- Brain size matters
- Proportions and relative size matter

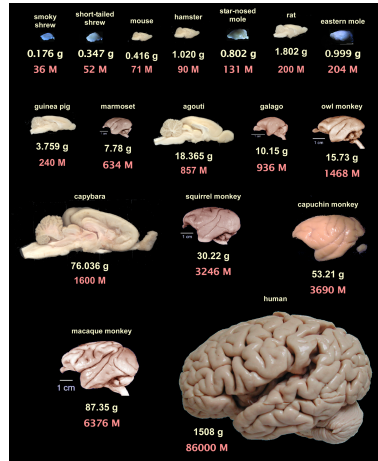

The human brain in numbers [...], S. Herculano-Houzel, *Frontier in Human Neuroscience*, 2009

What really matters for cognition ?

Specific structures ?

- Neocortex
- Basal Ganglia
- Amygdala
- Frontal cortex

Specific abilities ?

- To recognize self/others
- To imitate
- To use tools
- To communicate

Specific architecture ?

- Connectivity
- Density
- Modularity
- Self-organisation



Theoretical frameworks

Biological framework

- Anatomical facts
- Physiological recordings
- Experimental data

Computational framework

- Computational paradigm
- Plasticity & learning
- Evaluation of models

Cognitive framework

- Subsumption architecture
- Embodied cognition
- Affordances, emotions, etc.

Philosophical framework

- Strong AI / Weak AI
- Emergence
- Theories of mind

Where do we start ?

What is/are the right biological level(s) of description ?

- Molecule ? → neurotransmitters
- Organelle ? → axons, dendrites, synapses
- Cell ? → neurons, glial cells
- Tissue ? → brain lobes & structures
- Organ ? → brain

Neural fields, between cells and tissue

- Complex Dynamic
- Large population
- Fast simulation

Spatio-temporal framework

Continuous space

G.Schöner, **Dynamical Systems Approaches to Cognition**, *The Cambridge Handbook of Computational Psychology*, 2008.

... stable patterns of neuronal activation ultimately steer the periphery into dynamical states, from which behavior emerges, without any need to ever abstract from the space-time contiguous processes that embody cognition.

Continuous time

JP Spencer, S Perone and JS Johnson, **The Dynamic Field Theory and Embodied Cognitive Dynamics**, *Toward a Unified Theory of Development: Connectionism and Dynamic Systems Theory Re-Considered*, 2009.

The first challenge is that sensori-motor systems evolve continuously in real time, but cognition can jump from one state to another, that is, from one thought to another

Computational Framework

Distributed, Asynchronous, Numerical & Adaptive

A unit is a set of arbitrary values that can vary along time under the influence of other units and learning.

- Distributed
→ No supervisor nor executive
- Asynchronous
→ No central clock
- Numerical
→ No symbols
- Adaptive
→ No a priori knowledge

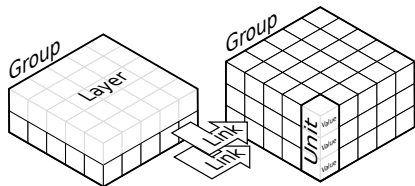

We want to make sure that emerging properties are those of the model and not those of the software running the model (see dana.loria.fr).

Neural Fields

Wilson & Cowan (1972), Amari (1977)

Equation

Let $u(\mathbf{x}, t)$ be the membrane potential at position \mathbf{x} and time t , f a transfer function and w a kernel of lateral interaction. The temporal evolution of $u(\mathbf{x}, t)$ is given by:

$$\tau \cdot \frac{\partial u(\mathbf{x}, t)}{\partial t} = -u(\mathbf{x}, t) + \int_{-\infty}^{+\infty} w(\mathbf{x}, y) \cdot f(u(\mathbf{y}, t)) dy + I(\mathbf{x}) + h$$

time constant
leak term
lateral interactions
input
resting potential

Velocity

Unless specified otherwise, we'll generally consider infinite speed, i.e. instantaneous transmission of information.

Neural Fields

Wilson & Cowan (1972), Amari (1977)

Function

The activity of a neural field can be interpreted from a functional point of view.

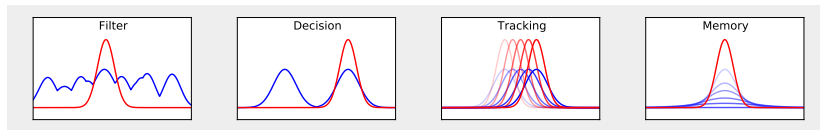

Measure

Using a specific set of parameters, the activity of a neural field can also be interpreted as a measure of the input.

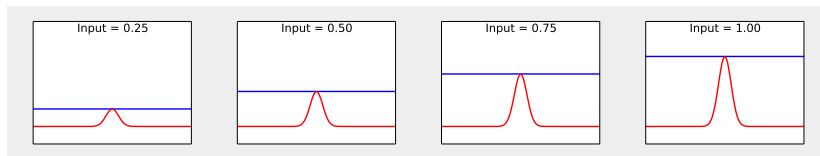

A dense crowd of yellow Minions with large, round eyes and black goggles. They are wearing blue overalls and have various expressions, including smiling, shouting, and looking surprised. The background is dark, making the yellow Minions stand out.

Visual Attention

On ne voit que ce que l'on regarde

(We only see what we look at)

“L'Œil et l'Esprit”, Maurice Merleau Ponty, 1961

Everyone knows what attention is. It is the possession by the mind, in clear and vivid form, of one out of what seem several simultaneously possible objects or trains of thought. Focalization, concentration, of consciousness are of its essence. It implies **withdrawal from some things in order to deal effectively with others**, and is a condition which has a real opposite in the confused, dazed, scatterbrained state which in French is called *distraction*, and *Zerstreutheit* in German.

W. James, 1890

How much blind are you ?

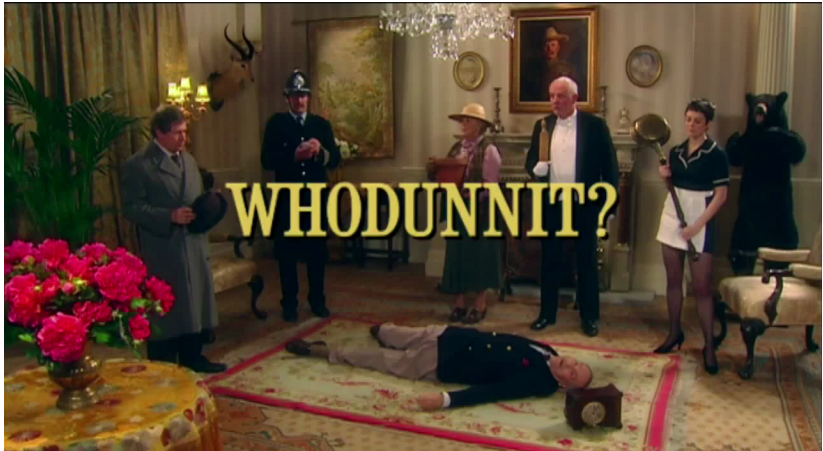

The grand illusion of seeing...

- Images on retina are formed upside-down
- There is a blind spot on the retina where optic nerves passes through it
- Retina receptors are not uniformly distributed over the surface of the retina
- Eye is always moving even when fixing a point (micro-tremors)

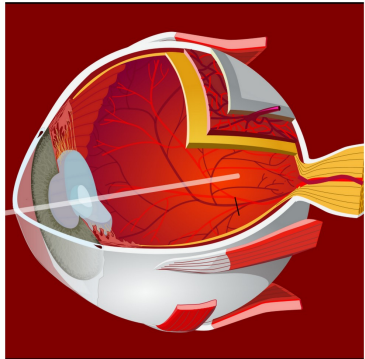

The many visual pathways

(Felleman & Van Essens, 1991)

The dorsal pathway

- *Where or How* pathway
- Motion and object locations

The ventral pathway

- *What* pathway
- Form and object representation

The frontal pathway

- Executive control
- Organization of behavior
- Visual Awareness

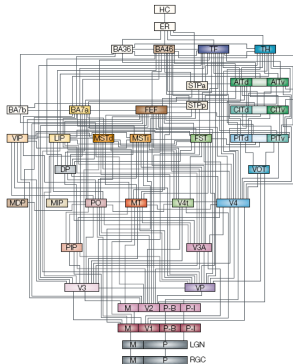

32 cortical areas, 10 hierarchical levels

Visual exploration

(Yarbus, 1967)

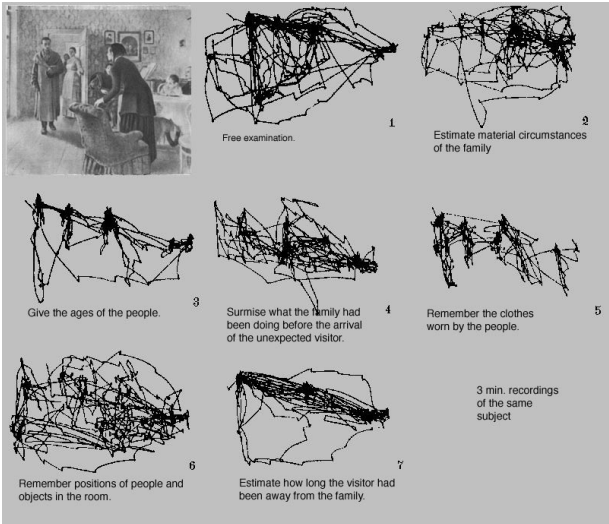

Free examination.

1

Estimate material circumstances of the family

2

3

Give the ages of the people.

4

Surmise what the family had been doing before the arrival of the unexpected visitor.

5

Remember the clothes worn by the people.

6

Remember positions of people and objects in the room.

7

Estimate how long the visitor had been away from the family.

3 min. recordings of the same subject

Attention

Clinical Description (Sohlberg & Mateer, 1989)

Focused to respond discretely to a specific stimuli.

Sustained to maintain a consistent behavioral response

Selective to maintain attention in the face of distractors

Alternating to shift focus of attention

Divided to respond simultaneously to multiple tasks

Cognitive Description

Motor movements preparation, priming, etc.

Sensory auditory, visual, proprioception, etc.

Overt motor response (explicit)

Covert cognitive response (implicit)

Top-down goal driven, bias, etc.

Bottom-Up stimulus driven, pop-out, etc.

Visual Attention

Spotlight metaphor

Attention is the capacity to select a relevant region of the sensory space

- Topological region of the sensory space → **spatial attention**
- Featural region of the sensory space → **feature oriented attention**
- Object as such → **object oriented attention**



Parallel Search

Search for 'X'

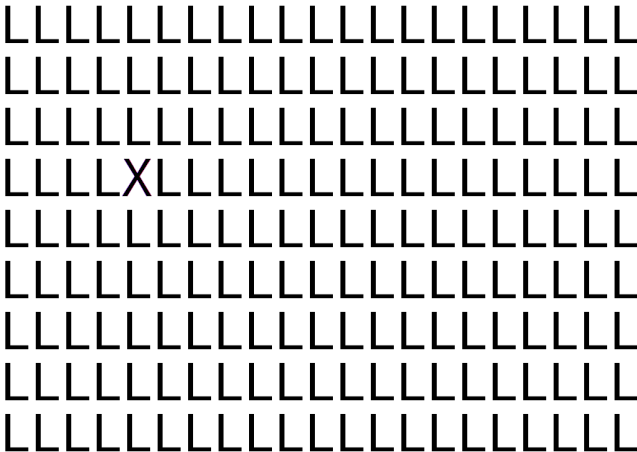

Parallel Search

Search for 'X'

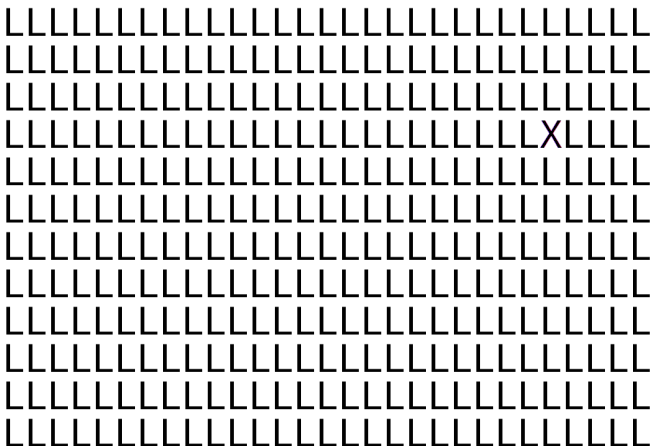

Parallel Search

Search for 'X'

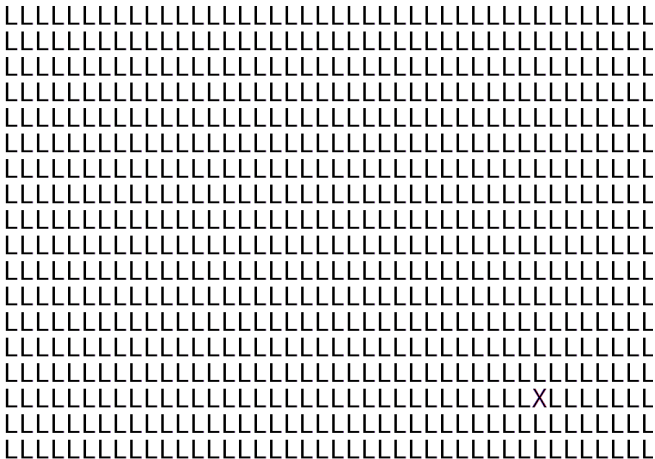

Sequential Search

Search for 'X'

FBYCPKNRAGCJSTIVNRWHM
CDOFAIKULWZBASUBIFOBI
JWUEVEQOUHEWHKAFIYJFG
LAMEQDPZKSHBJJQUUVCYO
FHINTDLLZSNLSGKTCNSVG
LACRYLSJJIFMZFHATXJDZ
JRUMNRYBPCHTNINTHEUWB
FRUWYBNYYYPPQOQFKIGJL
NIDBPINWAQGYPTRCLYVRU

A computational approach

Theories of Visual Attention

→ Saliency Maps (Itti & Koch, 2001)

Saliency map is a topographically arranged map that represents visual saliency of a corresponding visual scene.

- Inhibition Of Return (IOR, Posner, 1980)

IOR operates to decrease the likelihood that a previously inspected item in the visual scene will be reinspected.

- Premotor Theory of Attention (Rizzolati, 1987)

Attention may derive from weaker activation of same fronto-parietal circuits.

Saliency maps

(Itti & Koch, 2001)

Image



Saliency map



Saliency maps

(Rougier & Vitay, 2006)

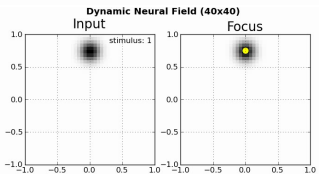
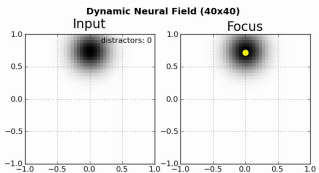
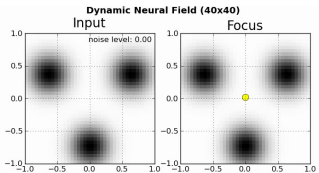

- Simple model of visual tracking
- Robustness to noise, distractors and saliency
- Dynamic & reactive behavior

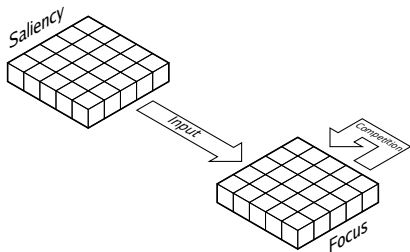

A computational approach

Theories of Visual Attention

- Saliency Maps (Itti & Koch, 2001)
Saliency map is a topographically arranged map that represents visual saliency of a corresponding visual scene.
- Inhibition Of Return (IOR, Posner, 1980)
IOR operates to decrease the likelihood that a previously inspected item in the visual scene will be reinspected.
- Premotor Theory of Attention (Rizzolati, 1987)
Attention may derive from weaker activation of same fronto-parietal circuits.

Inhibition of Return

(Posner, 1980)

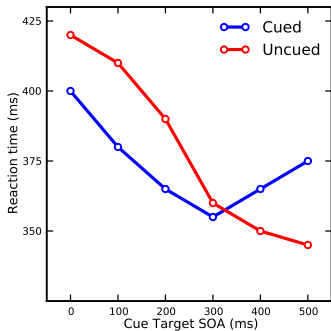
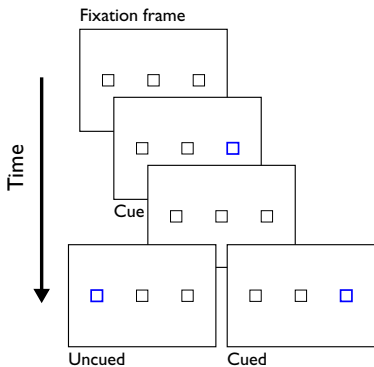

Inhibition of Return

(Vitay & Rougier, 2005)

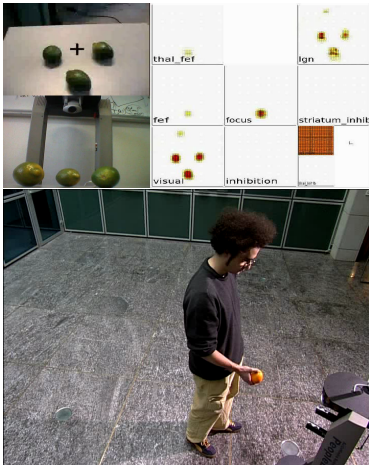

- Dynamic Working memory
- Biased competition
- Sequential behavior

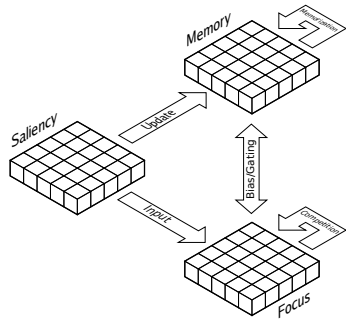

A computational approach

Theories of Visual Attention

- Saliency Maps (Itti & Koch, 2001)
Saliency map is a topographically arranged map that represents visual saliency of a corresponding visual scene.
 - Inhibition Of Return (IOR, Posner, 1980)
IOR operates to decrease the likelihood that a previously inspected item in the visual scene will be reinspected.
- Premotor Theory of Attention (Rizzolati, 1987)
Attention may derive from weaker activation of same fronto-parietal circuits.

Making saccades

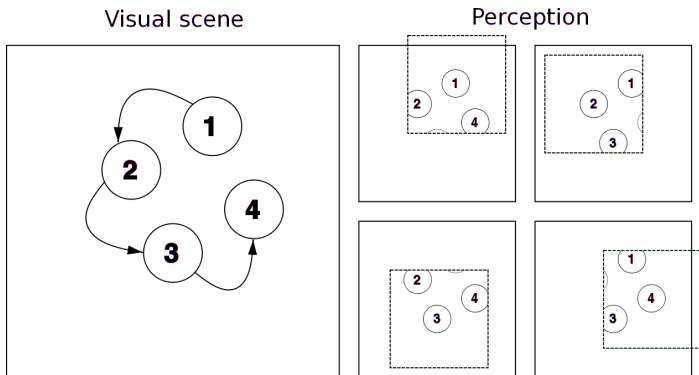

Ocular saccades lead to drastic changes in visual perception.

Visual anticipation

(Fix et al., 2007)

Spatial reference

- Independent of eye movements
- Eye-centered

Action in perception

- To anticipate the consequences of own actions
- To update working memory accordingly

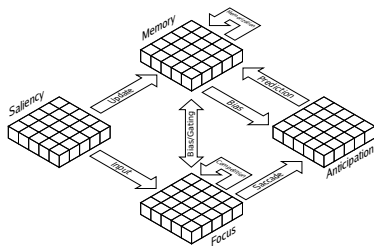

A model of covert and overt attention

(Fix et al., 2010)

Search task

The camera is placed in front of a visual scene and is able to pan and tilt. The task can be either to look for a specific orientation or colour or to look for a conjunction of such features.

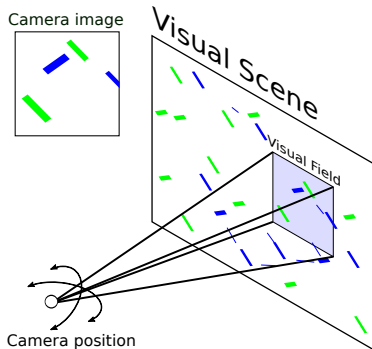

A model of covert and overt attention

(Fix et al., 2011)

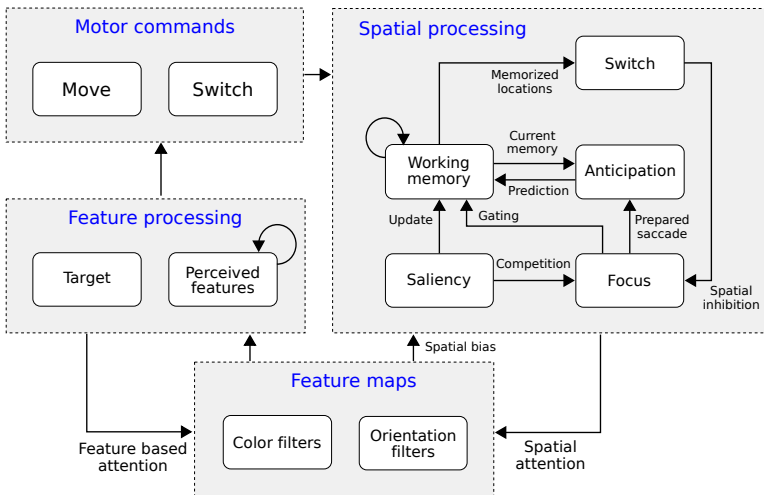

A model of covert and overt attention

(Fix et al., 2010)

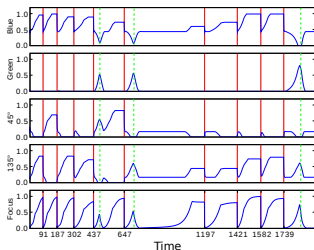
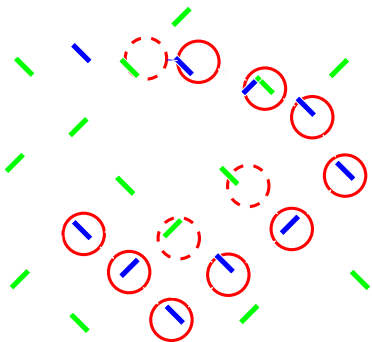

- Feature based attention facilitates processing of relevant features
- Spatial based attention facilitates processing of relevant region
- Working memory prevents to explore already seen location
- Model exhibits both overt and covert attention using same substrate

Towards the organization of visual behavior

A bottom-up sequential exploratory behavior has emerged based on distributed & numeric computation but...

From an automated behavior...

- Visual attention can be spatially or featurally biased
- Most salient stimulus are likely to be attended
- How to circumvent this *automated* behavior ?

...to a motivated one

- To consider saccadic behavior as a motivated exploration
- To make hypothesis about the world make saccades to try to confirm them

Decision Making

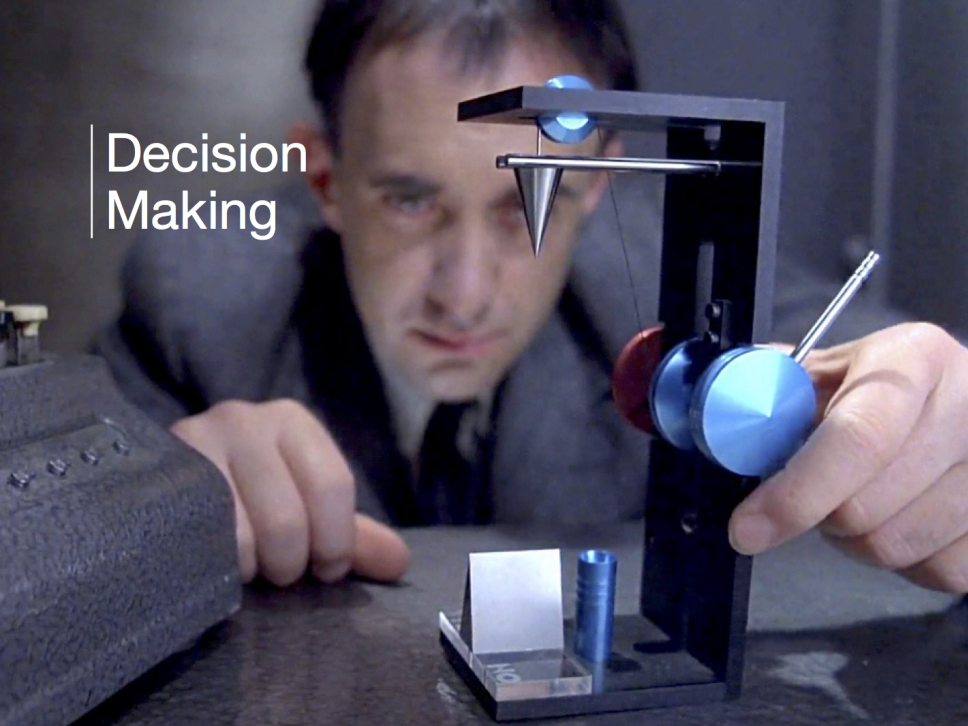

How a decision is made ?

Equation

Let $u(x,t)$ be the membrane potential at position x and time t , f a transfer function and w a kernel of lateral interaction. The temporal evolution of $u(x,t)$ is given by:

$$\tau \cdot \frac{\partial u(x,t)}{\partial t} = -u(x,t) + \int_{-\infty}^{+\infty} w(x,y) \cdot f(u(y,t)) dy + I(x) + h$$

time constant
leak term
lateral interactions
input
resting potential

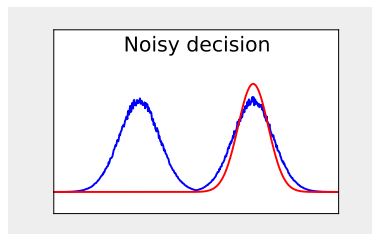
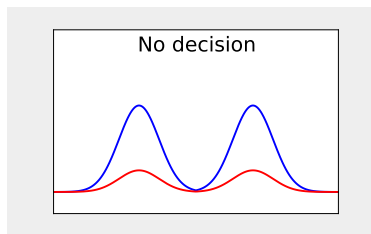

A degenerated neural field

Rougier & Hutt, 2012

$$\begin{cases} \dot{x} = \alpha \times (1 - x) + (x - y) \times (1 - x), x > 0 \\ \dot{y} = \alpha \times (1 - y) + (y - x) \times (1 - y), y > 0 \end{cases}$$

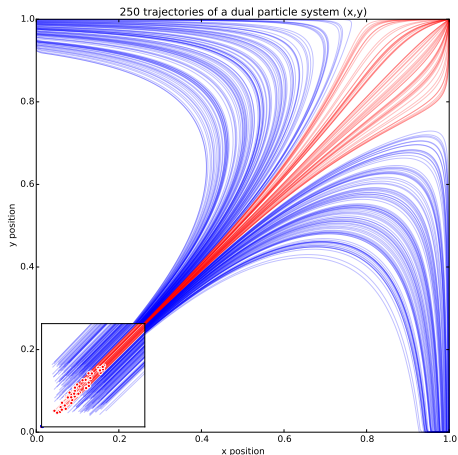

Superior Colliculus

Brain Stem - Midbrain

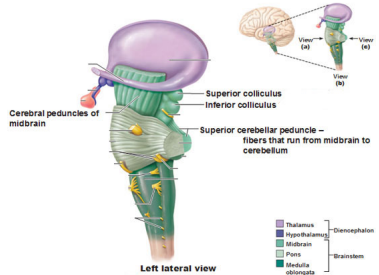
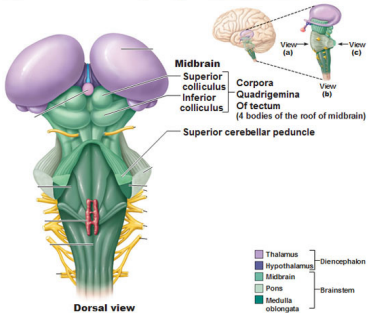

Superior colliculus

Structure & paths

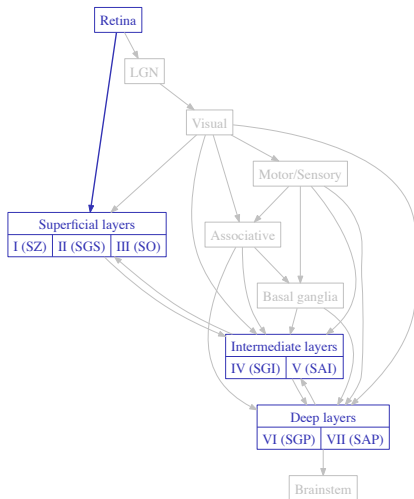

- **I (SZ)**: stratum zonale
- **II (SGS)**: stratum griseum superficiale
- **III (SO)**: stratum opticum
- **IV (SGI)**: stratum griseum intermediale
- **V (SAI)**: stratum album intermediale
- **VI (SGP)**: stratum griseum profundum
- **VII (SAP)**: stratum album profundum

Superior colliculus

A lot of questions

How are saccades encoded

- Population coding ? sum ? average ?
- What level of precision ?
- What does the receptive fields look like ?
- What is the influence of lesions ?

How decision is made ?

- What if two stimuli are presented ?
- What are the preferred stimuli ?

What is the dynamic ?

- What is the influence of stimulus size, magnitude or position ?
- What is the influence of distractors ?

Many computational models

A set of common hypotheses

Logarithmic projection

- (Optican 1995)
- (Lefèvre 1998)
- (Trappenberg 2001)
- (Nakahara, 2006)
- (Marino, 2008)
- ...

Homogeneous computation

- (Droulez & Berthoz, 1991)
- (Arai et al., 1994)
- (Gancarz & Grossberg, 1999)
- (Trappenberg, 2001)
- (Schneider & Erlhager, 2002)
- (Nakahara et al., 2006)
- (Marino 2012)
-

Logarithmic projection

(Optican, 1995)

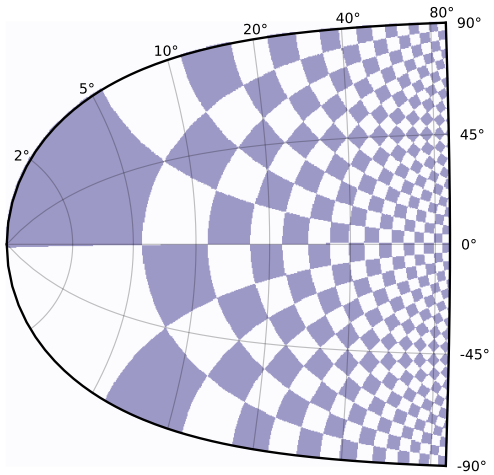
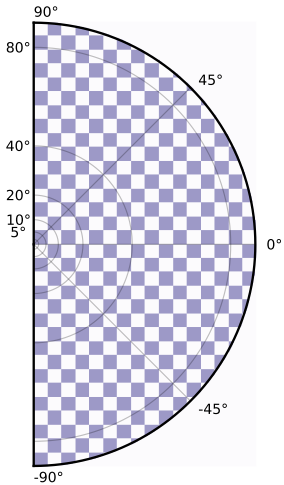

A minimal model

(Taouali et al, 2015 in revision)

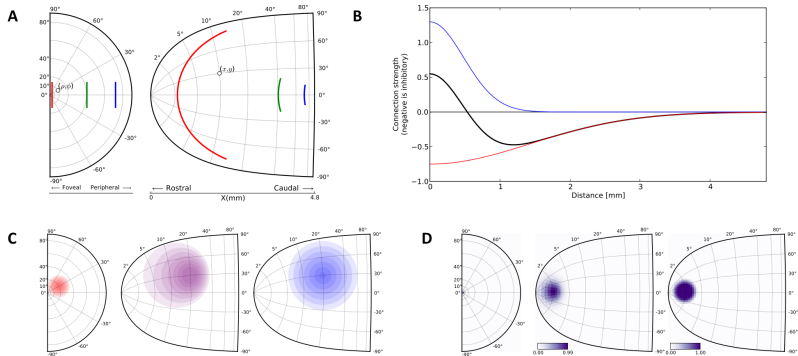

Receptive fields

Rostrally sharper & stronger, caudally broader & weaker

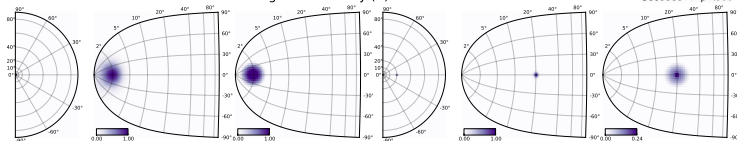
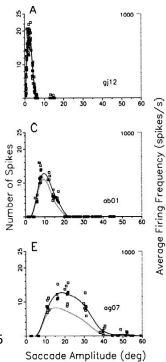
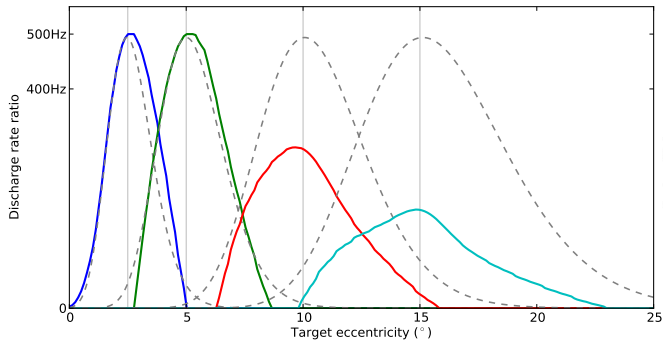

Influence of stimuli size

The bigger, the faster

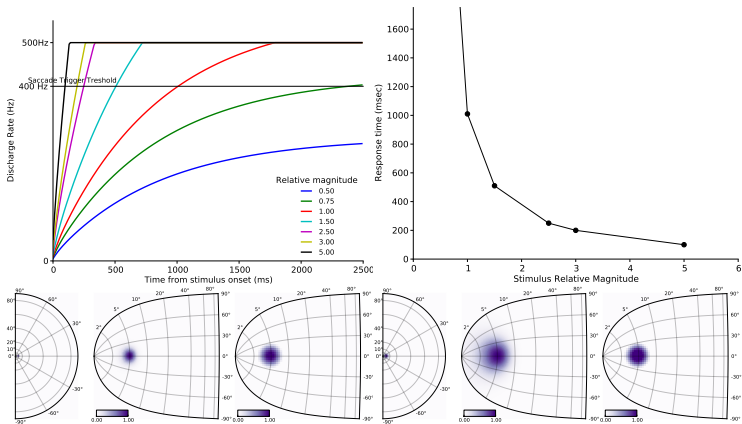

Influence of stimuli magnitude

The stronger, the faster

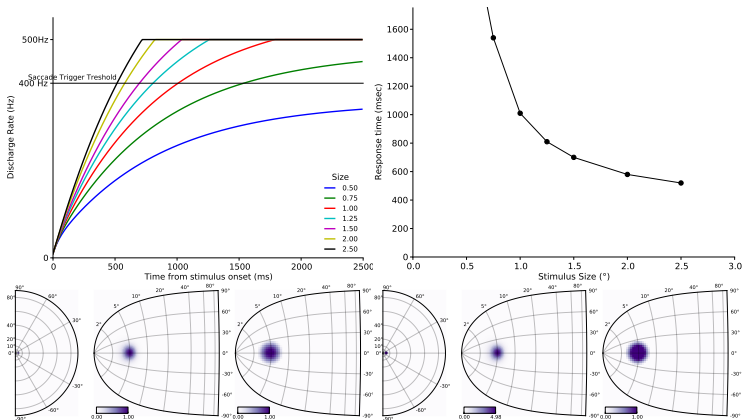

Influence of stimuli eccentricity

The nearer, the faster

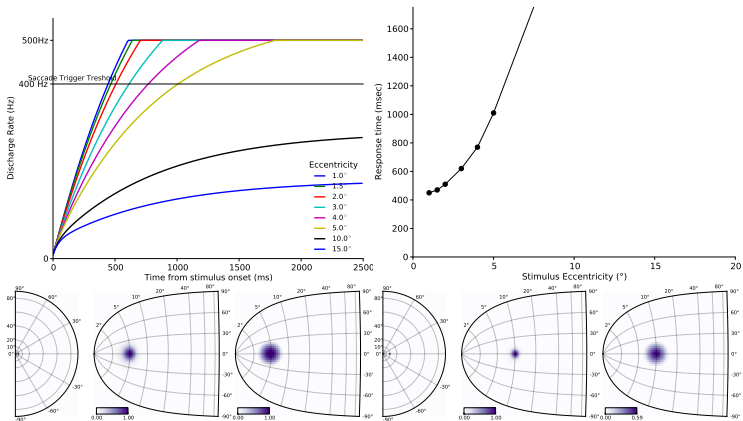

Decision

Where to look ?

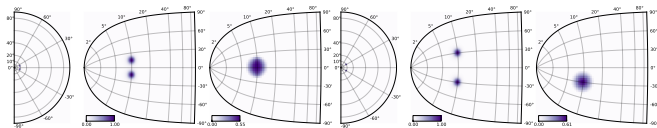
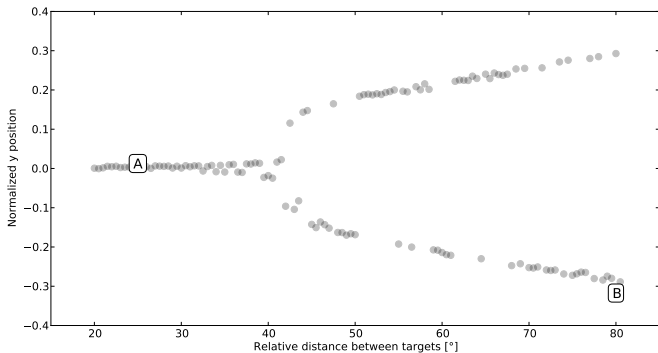

Dynamics

Latency effect

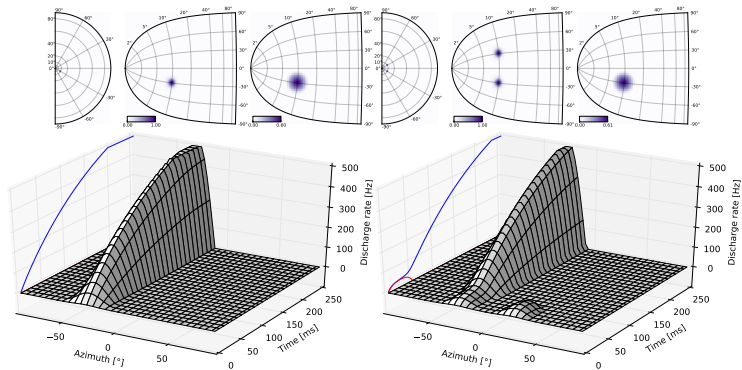

Encoding precision and lesion effect

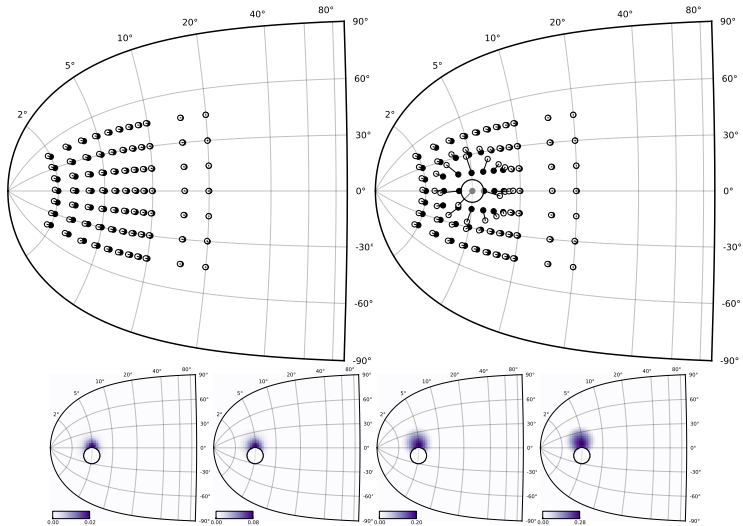

Conclusion

Major cognitive and behavioral functions emerge from such sensorimotor loops involving the external world, the body and the brain. We study, model

Embodiment constrains decision

The very shape of the retina provide an implicit computation that influence the final decision on where to saccade.

Cortical Plasticity

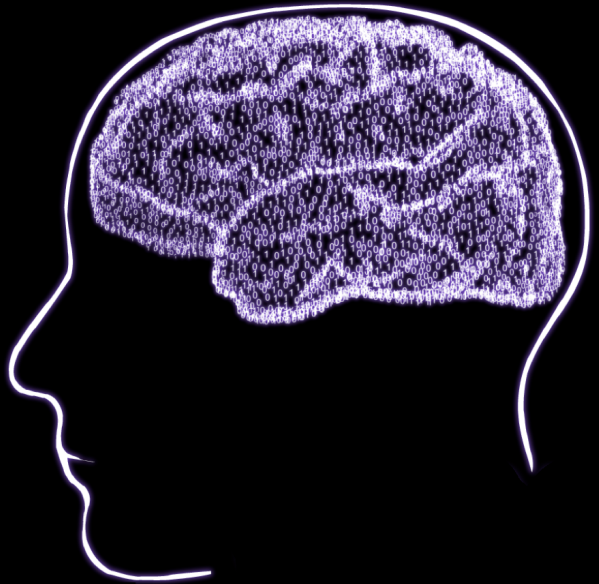

The Somatosensory System

Donald O. Hebb

- Neurons that fire together wire together

Hubel and Wiesel

- Simple and complex cells (1959)
- Ocular dominance columns (1962)
- *Critical period*, no plasticity after that period (1963-1965)

Merzenich, Kaas and Rasmusson

- Cortical organization of the primary somatosensory cortex (1981)
- Reorganization of the **adult** primary somatosensory cortex (1983)

The Somatosensory System

(Kandel, 2013)

A Somatosensory maps in the cortex of the owl monkey

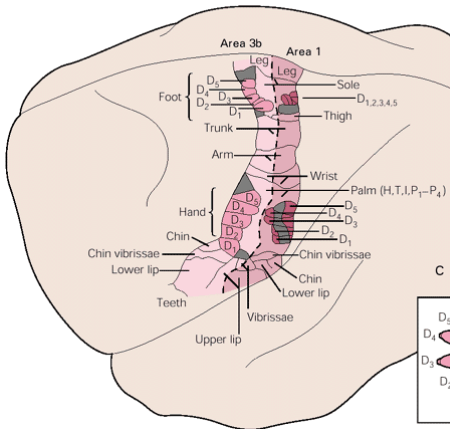

B Detail of representation of the palm

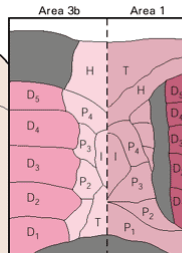

C Idealized somatosensory map of hands

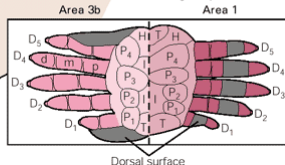

Plasticity in the Somatosensory System

(Florence, 2002)

Area 3b

Topographic organization of somatosensory cortical area 3b of owl monkeys after dorsal column transection.

- A. Normal somatotopy of the hand representation
- B. Complete dorsal column section at cervical levels deprives the hand representation of all activating inputs
- C. Over the course of weeks, the influence of the spared inputs expands

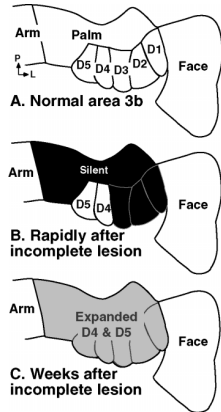

Plasticity in the Somatosensory System

- When, where and how organization occurs in the first place ?
- How representations can be both stable and plastic ?
- How to cope with cortical and/or sensory lesions ?
- Do current computational models give a fair account on cortical plasticity ?
- Are there other mechanisms or structures involved ?
- What is actually represented through cortical activity ?
- What is the role of the motor-sensory loop ?

Self-Organizing maps

(Kohonen, 1982)

Self-organization...

- Simple 2D topology
- Unsupervised learning
- Density driven

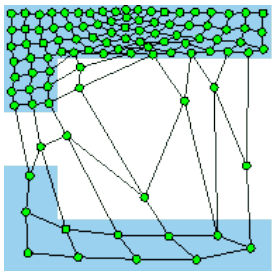

but...

- Decreasing neighborhood & learning rate
- Frozen terminal state
- *Winner-takes-all* algorithm

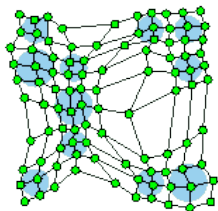
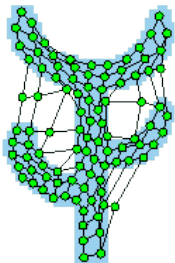

Neural Gas

(Martinetz et al., 1993)

Efficient VQ...

- Density driven
- Unsupervised learning
- No *dead* units

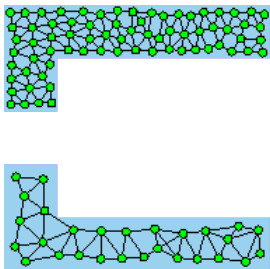

but...

- A posteriori topology
- Decreasing learning rate
- Frozen terminal state
- *Winner-takes-all* algorithm

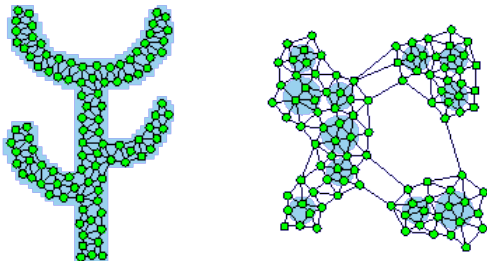

Dynamic Self-Organizing maps

(Rougier & Boniface, 2010)

To what extent it is possible to have both stable and dynamic representations ?

Dynamic

The model must dynamically adapts itself to the data.

Stability

Model representations must be stable if the input is stable.

Topology

Two physically neighborhood cells must have similar representations.

Dynamic Self-Organizing maps

(Rougier & Boniface, 2010)

DSOM is a neural map equipped with a structure (a hypercube or hexagonal lattice) and each neuron i is assigned a fixed position \mathbf{p}_i in \mathbb{R}^q where q is the dimension of the lattice (usually 1 or 2). The learning process is an iterative process where vectors $\mathbf{v} \in \Omega$ are sequentially presented to the map with respect to the probability density function f . For each presented vector \mathbf{v} , a winner $s \in \mathcal{N}$ is determined and all codes \mathbf{w}_i from the codebook \mathbf{W} are shifted towards \mathbf{v} according to

$$\Delta \mathbf{w}_i = \varepsilon \|\mathbf{v} - \mathbf{w}_i\|_{\Omega} h_{\eta}(i, s, \mathbf{v}) (\mathbf{v} - \mathbf{w}_i)$$

Dynamic Self-Organizing maps

(Rougier & Boniface, 2010)

Learning rate is modulated using the **closeness of the winner to the data**.

$$h_{\eta}(i, s, \mathbf{v}) = e^{-\frac{1}{\eta^2} \frac{\|\mathbf{p}_i - \mathbf{p}_s\|^2}{\|\mathbf{v} - \mathbf{w}_s\|_{\Omega}^2}}$$

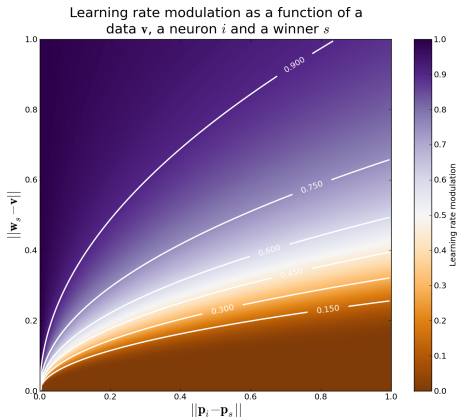

Dynamic Self-Organizing maps

(Rougier & Boniface, 2010)

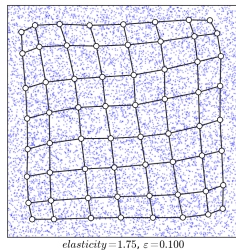
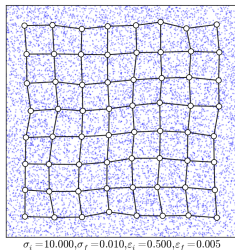
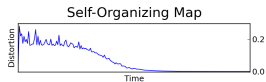
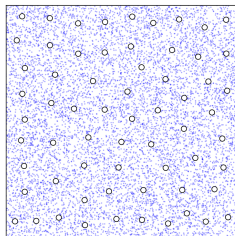
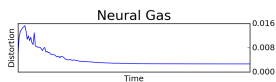

Dynamic Self-Organizing maps

(Rougier & Boniface, 2010)

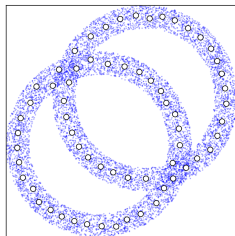
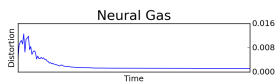

$$\lambda_i = 10.000, \lambda_j = 0.010, \varepsilon_i = 0.500, \varepsilon_j = 0.005$$

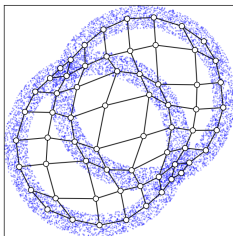
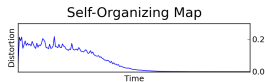

$$\sigma_i = 10.000, \sigma_j = 0.010, \varepsilon_i = 0.500, \varepsilon_j = 0.005$$

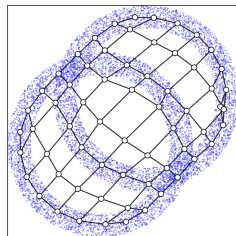

$$\text{elasticity} = 1.75, \varepsilon = 0.100$$

Dynamic Self-Organizing maps

(Rougier & Boniface, 2010)

Dynamic...

- Simple 2D topology
- Unsupervised learning
- No decreasing parameters

but...

- *Winner-takes-all* algorithm
- Elasticity tuning

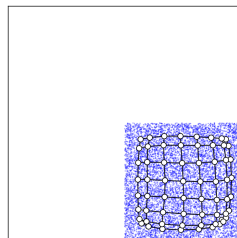
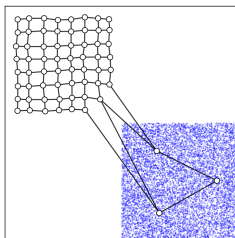
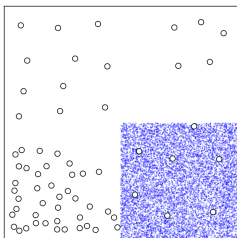
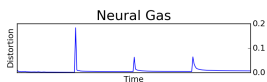

Neurophysiological evidence

Cortical organization

Laminar organization

- Six horizontal layers

Columnar organization

- minicolumns
- maxicolumns

Topographic organization

- retinotopy
- somatotopy
- sonototopy

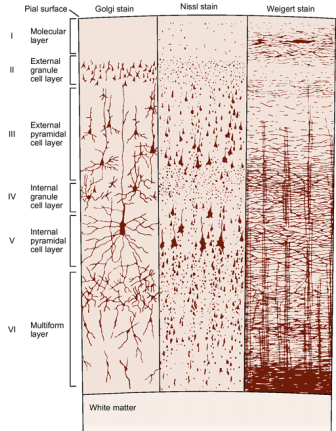

Dynamic Neural Fields

(Rougier & Detorakis, 2011)

Equation

Let $u(\mathbf{x}, t)$ be the membrane potential at position \mathbf{x} and time t , f a transfer function and w a kernel of lateral interaction. The temporal evolution of $u(\mathbf{x}, t)$ is given by:

$$\tau \cdot \frac{\partial u(x, t)}{\partial t} = -u(x, t) + \int_{-\infty}^{+\infty} w(x-y) \cdot f(u(y, t)) dy + I(x) + h$$

time constant
leak term
lateral interactions
input
resting potential

Matching property

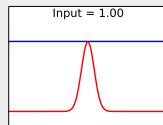
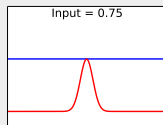
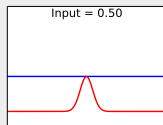
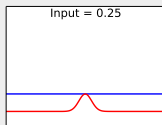

Dynamic Neural Fields

(Rougier & Detorakis, 2012)

Dynamic gain modulation

Dynamic gain enforces competition and can further modulate learning.

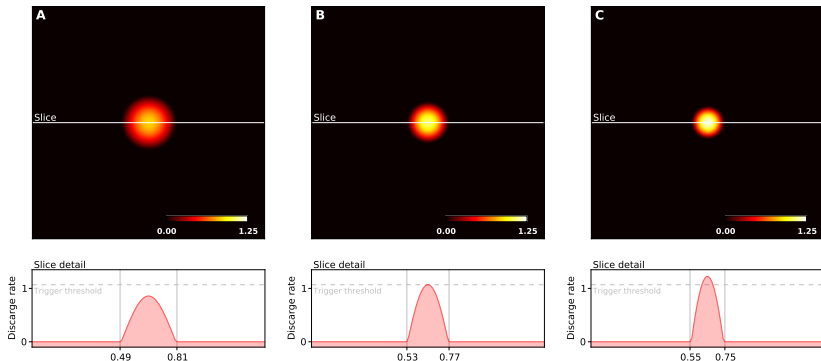

Dynamic Neural Fields

(Rougier & Detorakis, 2011)

Competition

Let $\mathbf{u}(\mathbf{x}, \mathbf{t})$ be the membrane potential at position \mathbf{x} and time \mathbf{t} , \mathbf{f} a transfer function and \mathbf{w} a kernel of lateral interaction. The temporal evolution of $\mathbf{u}(\mathbf{x}, \mathbf{t})$ is given by:

$$\tau \cdot \frac{\partial u(\mathbf{x}, t)}{\partial t} = -u(\mathbf{x}, t) + \int_{-\infty}^{+\infty} w_l(\mathbf{x}, y) \cdot f(u(\mathbf{y}, t)) dy + I(\mathbf{x}) + h$$

time constant
leak term
lateral interactions
input
resting potential

Learning

Learning occurs at every time step.

$$\tau \cdot \frac{\partial w_f(\mathbf{x}, t)}{\partial t} = \gamma (s(\mathbf{z}, t) - w_f(\mathbf{x}, t)) \int_{-\infty}^{+\infty} w_e(\mathbf{x}, y) f(u(\mathbf{y}, t)) dy$$

time constant
learning rate
thalamo-cortical
excitatory lateral

Using $w_l(\mathbf{x}, y) = w_e(\mathbf{x}, y) - w_i(\mathbf{x}, y) = K_e \exp\left(\frac{-d^2}{2\sigma_e^2}\right) - K_i \exp\left(\frac{-d^2}{2\sigma_i^2}\right)$

Computational model of area 3b

Architecture

Skin model

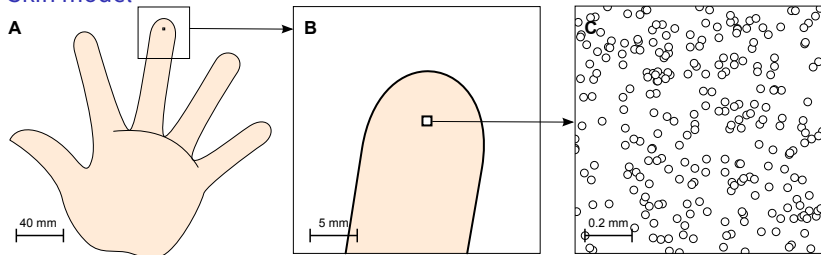

Non Toric

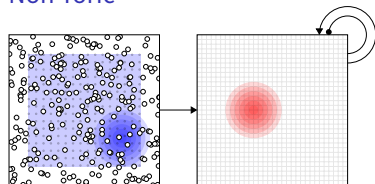

Toric

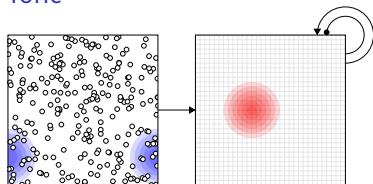

Computational model of area 3b

Architecture

- Neural field promotes competition
- Lateral connections are fixed and dynamic
- Feed-forwards connections are plastic
- Learning shapes receptive fields

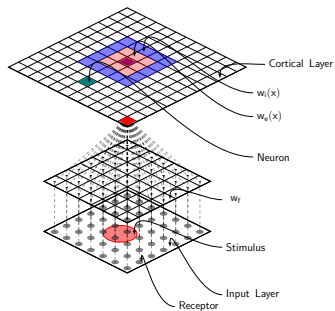

Computational model of area 3b

Initial organization

- Model has been trained on 50000 random samples
- Learning occurs at every time step
- Thalamo-cortical connections have been shaped
- Receptive fields covers uniformly the skin patch
- Topology is enforced everywhere

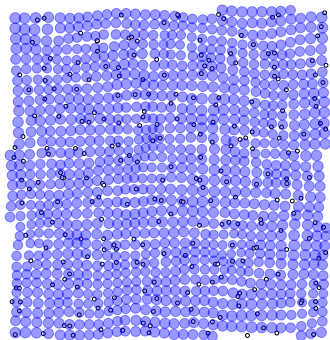

Computational model of area 3b

Shaping of (classical) receptive fields

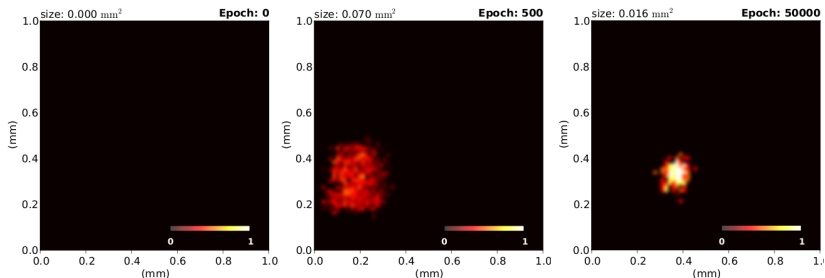

Temporal evolution of a receptive field



The shaping of receptive fields occurs through an early expansion stage followed by a shrinking and a specialization stage.

Cortical lesion

Reorganization and expansion of receptive fields

- 25% of neurons are killed
- 3 types of lesion
 - 
 - 
 - 
- Reorganization in three phases
 - Silence
 - Expansion
 - Shrinkage
- Expansion to non-represented skin areas.
- Partial recovery

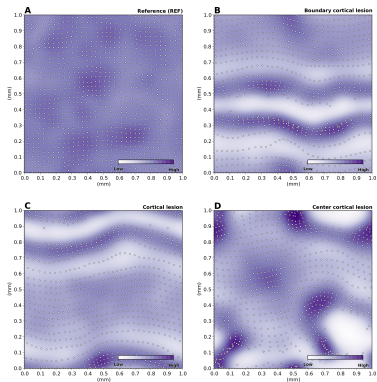

Cortical lesion

Reorganization and expansion of receptive fields

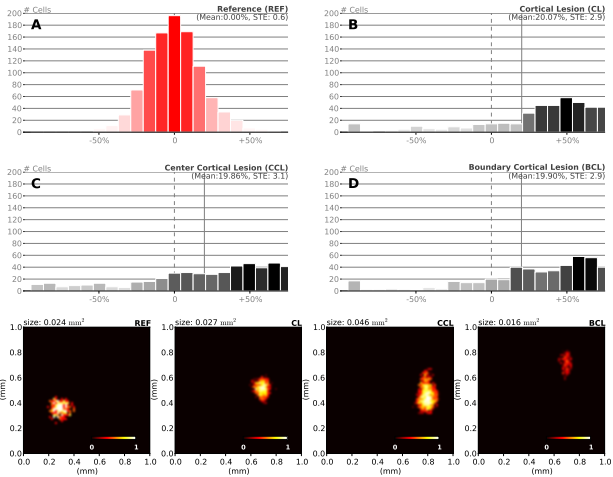

Sensory deprivation

Reorganization and shrinking of receptive fields

- 25% of receptors are silenced
- 3 types of lesion

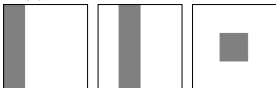

- Reorganization in three phases
 - Silence
 - Expansion
 - Shrinkage
- Migration of receptive fields
- Full recovery

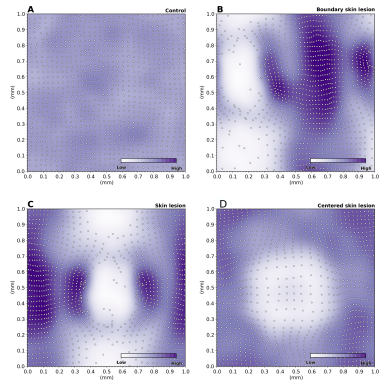

Sensory lesion

Reorganization and shrinking of receptive fields

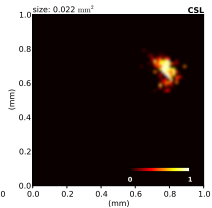
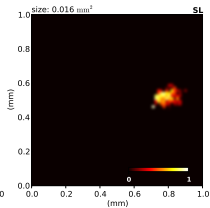
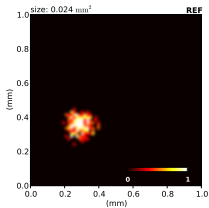
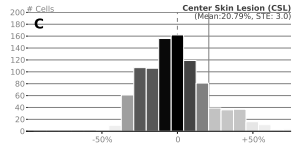
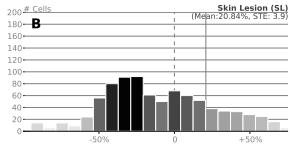

Structure of Receptive Fields...

...in Area 3b of Primary Somatosensory Cortex in the Alert Monkey (DiCarlo et al, 1998)

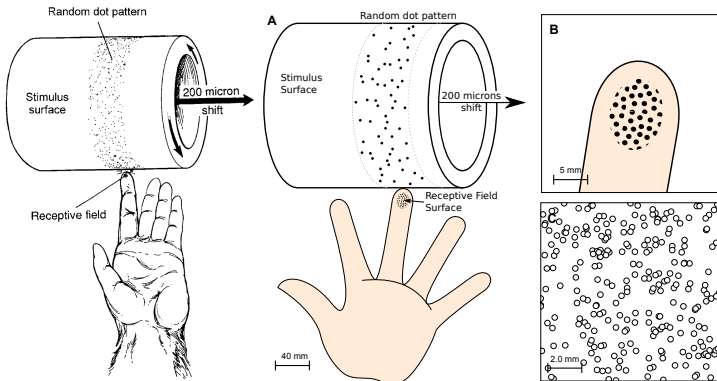

Structure of Receptive Fields...

...in Area 3b of Primary Somatosensory Cortex in the Alert Monkey (DiCarlo et al, 1998)

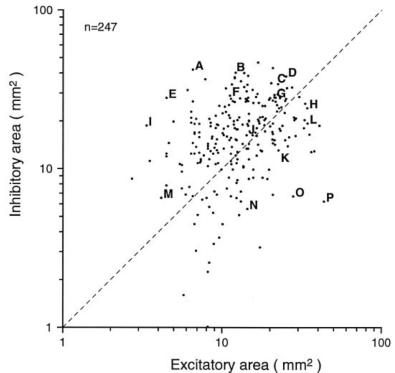
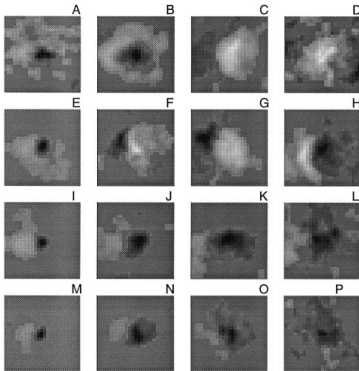

Influence of attention...

... on the structure of receptive fields in area 3b (Detorakis & Rougier, submitted)

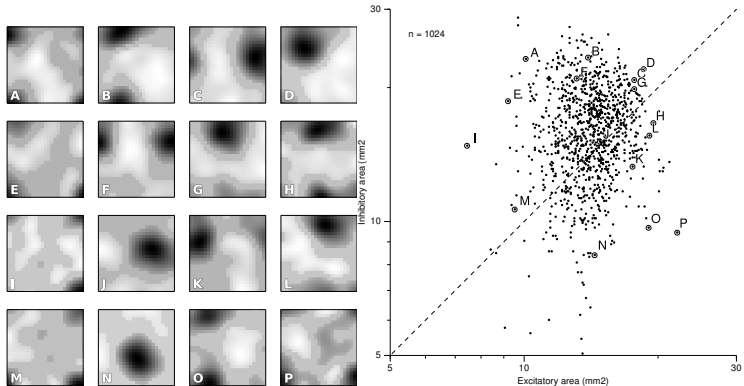

Some questions received (hypothetical) answers

- ✓ When, where and how organization occurs in the first place ?
- ✓ How representations can be both stable and plastic ?
- ✓ How to cope with cortical and/or sensory lesions ?
- ✓ Do current computational models give a fair account on cortical plasticity ?
- Are there other mechanisms or structures involved ?
- What is actually represented through cortical activity ?
- What is the role of the motor-sensory loop ?

Conclusion

Neural fields

- Powerful modeling tool
- Strong mathematical framework
- Experimental evidences

Cognition

- Still many questions to be addressed
- Embodiment and emergence are key concepts
- Mathematical analysis unlikely

Mathematical solutions do not characterize functional blocks

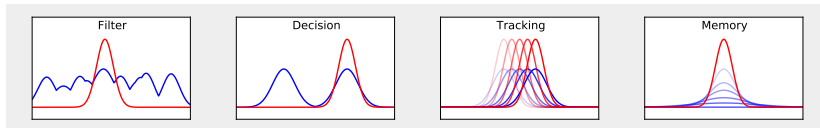

Is there something like an objective behavior ?

Curious (visual tracking) ?

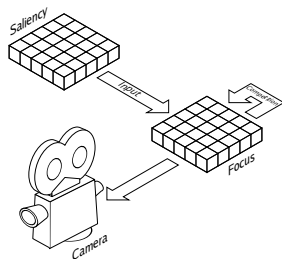

We can connect the model to a pan-tilt camera such that it follows a given stimulus

Shy (visual avoidance) ?

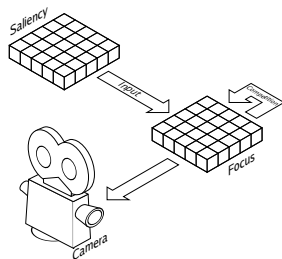

We can connect the model to a pan-tilt camera such that it looks away from a given stimulus

The actual behavior of the model depends on the links to its body. Ultimately, the modeler is the one who decide on the behavior.

What is a model ?

Supposons qu'un être (ou une situation) extérieur(e) X présente un comportement énigmatique, et que nous nous posions à son sujet une (ou plusieurs) question(s). Pour répondre à cette question, on va s'efforcer de **modéliser** X , c'est-à-dire, on va construire un objet (réel ou abstrait) M , considéré comme l'image, l'analogue de X : M sera dit le **modèle** de X .

R. Thom, *Modélisation et scientificité*, 1978

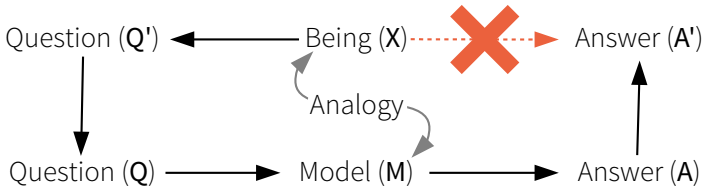

To an observer B, an object A^* is a model of an object A to the extent that B can use A^* to answer questions that interest him about A.

M. Minsky, *Matter, Mind and Models*, 1965

Evaluation of models

The standard model (theory)

provides a direct access to the question

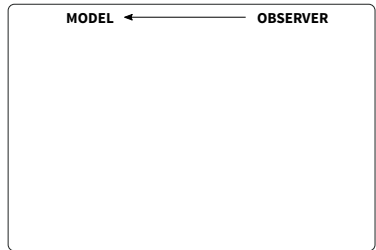

Evaluation of models

The standard model (theory)

provides a direct access to the question

The computational model

objective mathematical properties
subjective functional interpretations

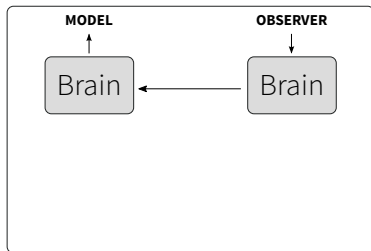

Evaluation of models

The standard model (theory)

provides a direct access to the question

The computational model

objective mathematical properties
subjective functional interpretations

The embodied model

behavior through embodiment
quantifiable performances

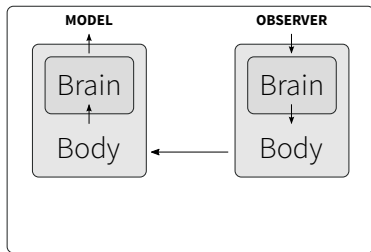

Evaluation of models

The standard model (theory)

provides a direct access to the question

The computational model

objective mathematical properties
subjective functional interpretations

The embodied model

behavior through embodiment
quantifiable performances

The cognitive model

observation through interaction
interpretation may depends on our own behavior

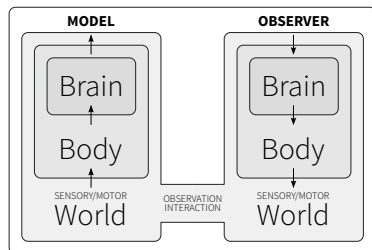

All code available on github or my homepage

- `http://www.labri.fr/perso/nrougier/`
- `https://github.com/rougier`

If not, mail to `nicolas.rougier@inria.fr`