

N° d'ordre: 4937



# THÈSE

présentée à

**L'UNIVERSITÉ BORDEAUX 1**

École Doctorale de Mathématiques et Informatique de Bordeaux

par

**Gabriel Renault**

pour obtenir le grade de

**DOCTEUR**

**SPÉCIALITÉ : INFORMATIQUE**

---

## **Jeux combinatoires dans les graphes**

---

Soutenue le 29 novembre 2013 au Laboratoire Bordelais de Recherche en Informatique (LaBRI)

Après avis des rapporteurs :

Michael ALBERT Professeur

Sylvain GRAVIER Directeur de recherche

Brett STEVENS Professeur

Devant la commission d'examen composée de :

**Examineurs**

Tristan CAZENAVE Professeur

Éric DUCHÊNE Maître de conférence

**Rapporteurs**

Sylvain GRAVIER Directeur de recherche

Brett STEVENS Professeur

**Directeurs de thèse**

Paul DORBEC Maître de conférence

Éric SOPENA Professeur



## Remerciements

Je voudrais d'abord remercier les rapporteurs et membres de mon jury de s'être intéressés à mes travaux, d'avoir lu ma thèse, assisté à ma soutenance et posé des questions évoquant de futurs axes de recherche sur le sujet. Merci beaucoup à Michael Albert, Sylvain Gravier et Brett Stevens d'avoir pris le temps de lire ma thèse en détail et exprimé des remarques pertinentes et constructives sur leurs rapports. Merci beaucoup à Tristan Cazenave d'avoir accepté de présider mon jury. Merci beaucoup à Éric Duchêne d'être venu de Lyon pour ma soutenance.

Je tiens à remercier plus particulièrement mes directeurs de thèse Paul Dorbec et Éric Sopena. Travailler avec eux a toujours été un plaisir, ils ont un don pour déterminer quels problèmes m'intéresseraient particulièrement. Ils m'ont fait confiance en acceptant de m'encadrer pour mon stage de M2, puis pour ma thèse. Je les remercie aussi pour toutes les opportunités qu'ils m'ont apportées, que ce soit des expériences d'enseignement un peu différentes au sein de Math en Jeans et Maths à Modeler, des séjours de recherche ou des conférences. L'échange avec eux a aussi été très agréable sur le plan humain, c'était sympathique de pouvoir aussi parler en dehors d'un contexte de travail.

Je voudrais également remercier les personnes avec lesquelles j'ai eu l'occasion de travailler, en particulier Boštjan, Éric, Gašper, Julien, Rebecca, Richard, Sandi et Simon. C'est toujours intéressant de se pencher sur un problème avec quelqu'un qui peut avoir une vision un peu différente et d'arriver à une solution grâce à ces deux points de vue.

J'ai aussi eu la chance de participer aux séminaires du groupe de travail Graphes et Applications. Je remercie ses membres et plus particulièrement ceux qui ont été doctorants en même temps que moi, avec lesquels j'ai eu le plus d'échange, Adrien, Clément, Émilie Florent, Hervé, Noël Petru, Pierre, Quentin, Romaric, Sagnik, Thomas et Tom. C'était aussi un plaisir de cotoyer les membres permanents, André, Arnaud, Cyril, David, Frantisek, Frédéric, Mickael, Nicolas, Nicolas, Olivier, Olivier, Philippe et Ralf.

Je remercie aussi les chercheurs en graphes et jeux que j'ai eu la chance de rencontrer en conférence ou séjour de recherche, parmi lesquels Aline, André, Ararat, Benjamin, Guillem, Guillaume, Jean-Florent, Julien, Laetitia, Laurent, Louis, Marthe, Neil, Nicolas, Paul, Reza, Théophile et Urban.

J'ai eu la chance d'enseigner à l'Université Bordeaux 1, et je voudrais remercier les enseignants qui m'ont accompagné pour ce parcours, notamment Aurélien, Christian, David, Frédéric, Frédérique, Jean-Paul, Pascal, Pierre, Pierre et Vincent. Je tiens également à remercier Marie-Line avec laquelle j'ai pu encadrer l'activité Math en Jeans à l'université.

Je remercie aussi toute l'équipe administrative du LaBRI pour leur efficacité, leur amabilité et leur bonne humeur, en particulier ceux avec lesquels

j'ai eu le plus d'occasions de discuter, Brigitte, Cathy, Isabelle, Lebna, Maïté et Philippe.

Je voudrais remercier les doctorants qui ont participé à faire vivre le bureau 123 via des débats et discussions, en particulier Amal, Benjamin, Christian, Christopher, Edon, Eve, Florian, Jaime, Jérôme, Lorian, Lucas, Matthieu, Nesrine, Omar, Oualid, Pierre, Sinda, Tom, Tung, Van-Cuong, Wafa et Yi.

La vie au labo aurait été différente sans les activités organisées par l'AFoDIB, et les sorties entre doctorants. Je remercie leurs participants les plus fréquents, parmi ceux qui n'ont pas encore été cités, Abbas, Adrien, Allyx, Anaïs, Anna, Carlos, Cedric, Cyril, David, Dominik, Etienne, Fouzi, Jérôme, Lorenzo, Martin, Matthieu, Noémie-Fleur, Razanne, Rémi, Simon, Srivathsan, Thomas, Vincent et Xavier.

J'ai aussi eu des contacts en dehors de la sphère de l'université. Je voudrais remercier mes amis avec lesquels mes sujets de discussions variaient un peu en comparaison, ou qui m'ont permis de vulgariser mes travaux, en particulier Alexandre, Amélie, Benjamin, Cécile, Clément, Emeric, Ena, Guilhem, Irène, Jonas, Kévin, Laure, Nolwenn, Ophélie, Pierre, Rémi et Romain. Je citerai aussi les emails du RATONLAVEUR qui pouvaient participer à me mettre de bonne humeur.

Je voudrais aussi remercier ma famille pour des raisons similaires, ainsi que pour m'avoir fait confiance et encouragé dans la voie que je voulais suivre. Je remercie mes parents, mes frères et sœur, mes grands-parents, oncles, tantes, cousins et cousines. Un remerciement spécial à Xiaohan qui a donné une autre dimension à la vulgarisation en me poussant à la réaliser en anglais. 非常感谢小涵

---

## Jeux combinatoires dans les graphes

---

**Résumé :** Dans cette thèse, nous étudions les jeux combinatoires sous différentes contraintes. Un jeu combinatoire est un jeu à deux joueurs, sans hasard, avec information complète et fini acyclique. D'abord, nous regardons les jeux impartiaux en version normale, en particulier les jeux VERTEXNIM et TIMBER. Puis nous considérons les jeux partisans en version normale, où nous prouvons des résultats sur les jeux TIMBUSH, TOPPLING DOMINOES et COL. Ensuite, nous examinons ces jeux en version misère, et étudions les jeux misères modulo l'univers des jeux dicots et modulo l'univers des jeux dead-endings. Enfin, nous parlons du jeu de domination qui, s'il n'est pas combinatoire, peut être étudié en utilisant des outils de théorie des jeux combinatoires.

---

**Mots-clés :** jeux combinatoires, graphes, jeux impartiaux, jeux partisans, version normale, version misère, jeu de domination

---

## Combinatorial games on graphs

---

**Abstract:** In this thesis, we study combinatorial games under different conventions. A combinatorial game is a finite acyclic two-player game with complete information and no chance. First, we look at impartial games in normal play and in particular at the games VERTEXNIM and TIMBER. Then, we consider partizan games in normal play, with results on the games TIMBUSH, TOPPLING DOMINOES and COL. Next, we look at all these games in misère play, and study misère games modulo the dicot universe and modulo the dead-ending universe. Finally, we talk about the domination game which, despite not being a combinatorial game, may be studied with combinatorial games theory tools.

---

**Keywords:** combinatorial games, graphs, impartial games, partizan games, normal convention, misère convention, domination game

# Contents

<b>1</b>	<b>Introduction</b>	<b>1</b>
1.1	Definitions . . . . .	2
1.1.1	Combinatorial Games . . . . .	2
1.1.2	Graphs . . . . .	6
<b>2</b>	<b>Impartial games</b>	<b>13</b>
2.1	VERTEXNIM . . . . .	14
2.1.1	Directed graphs . . . . .	16
2.1.2	Undirected graphs . . . . .	21
2.2	TIMBER . . . . .	26
2.2.1	General results . . . . .	27
2.2.2	Trees . . . . .	32
2.2.2.1	Paths . . . . .	39
2.3	Perspectives . . . . .	40
<b>3</b>	<b>Partizan games</b>	<b>43</b>
3.1	TIMBUSH . . . . .	44
3.1.1	General results . . . . .	45
3.1.2	Paths . . . . .	49
3.1.3	Black and white trees . . . . .	54
3.2	TOPPLING DOMINOES . . . . .	61
3.2.1	Preliminary results . . . . .	63
3.2.2	Proof of Theorem 3.27 . . . . .	65
3.3	COL . . . . .	72
3.3.1	General results . . . . .	76
3.3.2	Known results . . . . .	80
3.3.3	Caterpillars . . . . .	93
3.3.4	Cographs . . . . .	96
3.4	Perspectives . . . . .	98
<b>4</b>	<b>Misère games</b>	<b>101</b>
4.1	Specific games . . . . .	104
4.1.1	GEOGRAPHY . . . . .	105
4.1.2	VERTEXNIM . . . . .	111
4.1.3	TIMBER . . . . .	113
4.1.4	TIMBUSH . . . . .	116
4.1.5	TOPPLING DOMINOES . . . . .	117

---

4.1.6	COL . . . . .	119
4.2	Canonical form of dicot games . . . . .	126
4.2.1	Definitions and universal properties . . . . .	127
4.2.2	Canonical form of dicot games . . . . .	130
4.2.3	Dicot misère games born by day 3 . . . . .	136
4.2.3.1	Dicot games born by day 3 in the general universe . . . . .	143
4.2.4	Sums of dicots can have any outcome . . . . .	146
4.3	A peek at the dead-ending universe . . . . .	147
4.3.1	Preliminary results . . . . .	149
4.3.2	Integers and other dead ends . . . . .	151
4.3.3	Numbers . . . . .	153
4.3.3.1	The misère monoid of $\mathcal{Q}_2$ . . . . .	153
4.3.3.2	The partial order of numbers modulo $\mathcal{E}$ . . . . .	158
4.3.4	Zeros in the dead-ending universe . . . . .	160
4.4	Perspectives . . . . .	161
<b>5</b>	<b>Domination Game</b>	<b>167</b>
5.1	About no-minus graphs . . . . .	169
5.2	The domination game played on unions of graphs . . . . .	172
5.2.1	Union of no-minus graphs . . . . .	172
5.2.2	General case . . . . .	175
5.3	Perspectives . . . . .	179
<b>6</b>	<b>Conclusion</b>	<b>181</b>
<b>A</b>	<b>Appendix: Rule sets</b>	<b>185</b>
<b>B</b>	<b>Appendix: Omitted proofs</b>	<b>189</b>
B.1	Proof of Theorem 3.30 . . . . .	189
B.2	Proof of Theorem 3.31 . . . . .	195
B.3	Proof of Lemma 3.80 . . . . .	201
	<b>Bibliography</b>	<b>213</b>



## Chapter 1

# Introduction

Combinatorial games are games of pure strategy, closer to Checkers, Chess or Go than to Dominion, League of Legends, or Rugby. They are games satisfying some constraints insuring a player has a winning strategy. Our goal here is to find which player it is, and even the strategy if possible.

There exist other game theories, such as economic game theory, where there might be several players, who are allowed to play their moves at the same time. There, the players' 'best' strategies are often probabilistic, that is for example a player would decide to play the move  $A$  with probability 0.3, the move  $B$  with probability 0.5, and the move  $C$  with probability 0.2, because they do not know what their opponent might do and each of these moves might be better than the other depending on the opponent's move. In combinatorial game, this does not happen, the 'winning' player always has a deterministic winning strategy.

The first paper in combinatorial game theory was published in 1902 by Bouton [5], who solved the game of NIM, game that would become the reference in impartial games thanks to the theory developed independently by Grundy and Sprague in the 30s. For a few decades, researchers studied the games where both players have the same moves and are only distinguished by who plays first, games we call impartial. In the late 70s, Berlekamp, Conway and Guy developed the theory of partizan games, where the two players may have different moves. These games introduce many more possibilities, as for example a player might have a winning strategy whoever starts playing. The complexity of determining the winner of a combinatorial game was also considered, ranging from polynomial problems to EXPTIME-complete problems. Another topic in combinatorial game theory that has interested researchers is the *misère* version of a game, that is the game where the winning condition is reversed. These games were not well understood, mainly because when they decompose, it is harder to put together the separate analysis of the components, until Plambeck and Siegel proposed a way to make it simpler in the beginning of the 21<sup>st</sup> century. References about the topic include the books *Winning Ways* [4] and *On Numbers and Games* [10], and other books that were published more recently, such as *Lessons in Play* [1], *Games, Puzzles, & Computation* [11] and *Combinatorial Game Theory* [39].

Graph theory is more ancient, Euler was already looking at it in the 18<sup>th</sup> century. A graph is a mathematical object that can be used to represent any kind of network, such as computer networks, road networks, social networks,

or neural networks.

Natural questions that arise on these networks can be translated under a graph formalism. Among classic graph problems, one can mention colouring and domination. These problems admit variants that are two-player games, where the players may build an answer to the original problem.

In this thesis, we study combinatorial games, mostly games played on graphs. We first give some basic definitions on games and graphs, before presenting our results on games. We start with impartial games before going to partizan games and continuing with games in misère play. We end with a game that is not combinatorial but is more like a graph parameter.

---

<b>1.1</b>	<b>Definitions . . . . .</b>	<b>2</b>
1.1.1	Combinatorial Games . . . . .	2
1.1.2	Graphs . . . . .	6

---



---

## 1.1 Definitions

---

### 1.1.1 Combinatorial Games

A *combinatorial game* is a finite two-player game with perfect information and no chance. The players, called Left and Right, alternate moves until one player has no available move. Under the normal convention, the last player to move wins the game. Under the misère convention, that same player loses the game. By convention, Left is a female player whereas Right is a male player.

A position of a game can be defined recursively by its sets of options  $G = \{G^L | G^R\}$ , where  $G^L$  is the set of positions reachable in one move by Left (called Left options), and  $G^R$  the set of positions reachable in one move by Right (called Right options). The word game can be used to refer to a set of rules, as well as to a specific position as just described. A *follower* of a game is a game that can be reached after a succession of (not necessarily alternating) Left and Right moves. The zero game  $0 = \{\cdot | \cdot\}$ , is the game with no option (the dot indicates an empty set of options). The *birthday* of a game is defined recursively as one plus the maximum birthday of its options, with 0 being the only game with birthday 0. We say a game  $G$  is born *on day*  $n$  if its birthday is  $n$  and that it is born *by day*  $n$  if its birthday is at most  $n$ . The games born on day 1 are  $\{0 | \cdot\} = 1$ ,  $\{\cdot | 0\} = \bar{1}$  and  $\{0 | 0\} = *$ . The games born by day 1 are the same with the addition of 0. A game  $G$  is

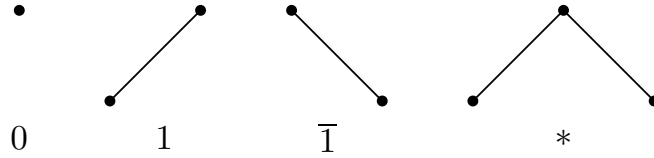


Figure 1.1: Game trees of games born by day 1.

said to be *simpler* than a game  $H$  if the birthday of  $G$  is smaller than the birthday of  $H$ .

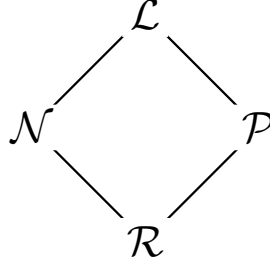
A game can also be depicted by its game tree, where the game trees of its options are linked to the root by downward edges, left-slanted for Left options and right-slanted for Right options. For instance, the game trees of games born by day 1 are depicted on Figure 1.1.

When the Left and Right options of a game are always the same and that property is true for any follower of the game, we say the game is *impartial*. Otherwise, we say it is *partizan*.

Given two games  $G = \{G^L|G^R\}$  and  $H = \{H^L|H^R\}$ , we recursively define the (*disjunctive*) *sum* of  $G$  and  $H$  as  $G + H = \{G^L + H, G + H^L|G^R + H, G + H^R\}$  (where  $G^L + H$  is the set of sums of  $H$  and an element of  $G^L$ ), i.e. the game where each player chooses on their turn which one of  $G$  and  $H$  to play on. We write  $\{G^{L_1} \dots G^{L_k}|G^{R_1} \dots G^{R_\ell}\}$  for  $\{\{G^{L_1} \dots G^{L_k}\}|\{G^{R_1} \dots G^{R_\ell}\}\}$  to simplify the notation. We denote by  $G^L$  any Left option of  $G$ , and by  $G^R$  any of its Right options. The *conjugate*  $\overline{G}$  of a game  $G$  is defined recursively by  $\overline{G} = \{\overline{G^R}|\overline{G^L}\}$  (where  $\overline{G^R}$  is the set of conjugates of elements of  $G^R$ ), that is the game where Left and Right would have switched their roles.

For both conventions, there are four possible outcomes for a game. Games for which Left has a winning strategy whatever Right does and whoever plays first have outcome  $\mathcal{L}$  (for *left*). Similarly,  $\mathcal{N}$ ,  $\mathcal{P}$  and  $\mathcal{R}$  (for *next*, *previous* and *right*) denote respectively the outcomes of games for which the first player, the second player, and Right has a winning strategy. We note  $o^+(G)$  the *normal outcome* of a game  $G$  i.e. its outcome under the normal convention and  $o^-(G)$  the *misère outcome* of  $G$ . We also say for any outcome  $\mathcal{O}$ ,  $G \in \mathcal{O}^+$  or  $G$  is a (normal)  $\mathcal{O}$ -position whenever  $o^+(G) = \mathcal{O}$ , and  $H \in \mathcal{O}^-$  or  $H$  is a (misère)  $\mathcal{O}$ -position when  $o^-(H) = \mathcal{O}$ . Outcomes are partially ordered according to Figure 1.2, with greater games being more advantageous for Left. Note that there is no general relationship between the normal outcome and the misère outcome of a game.

Given two games  $G$  and  $H$ , we say that  $G$  is greater than or equal to  $H$  in normal play whenever Left prefers the game  $G$  rather than the game  $H$  in any sum, that is  $G \geq^+ H$  if for every game  $X$ ,  $o^+(G + X) \geq o^+(H + X)$ . We say that  $G$  and  $H$  are equivalent in normal play, denoted  $G \equiv^+ H$ , when for every game  $X$ ,  $o^+(G + X) = o^+(H + X)$  (i.e.  $G \geq^+ H$  and  $H \geq^+ G$ ). We also say that  $G$  is (strictly) greater than  $H$  in normal play if  $G$  is greater than



**Figure 1.2:** Partial ordering of outcomes

or equal to  $H$  but  $G$  and  $H$  are not equivalent, that is  $G >^+ H$  if  $G \geq^+ H$  and  $G \not\equiv^+ H$ . We say that  $G$  and  $H$  are incomparable in normal play if none is greater than or equal to the other, that is  $G \parallel^+ H$  if  $G \not\geq^+ H$  and  $H \not\geq^+ G$ . Inequality, equivalence and incomparability are defined similarly under misère convention, using superscript  $-$  instead of  $+$ . We reserved the symbol  $=$  for equality between game trees, when used between games.

For normal play, there exist other characterisations for checking inequality:

$$\begin{aligned} G \geq^+ H &\Leftrightarrow G + \overline{H} \in \mathcal{P}^+ \cup \mathcal{L}^+ \\ &\Leftrightarrow (\forall G^R \in G^R, G^R \not\leq H) \wedge (\forall H^L \in H^L, G \not\leq H^L). \end{aligned}$$

The last characterisation was actually the original definition given by Conway in [10]. The second one tells us that for any games  $G$  and  $H$ , if  $G$  and  $H$  are equivalent in normal play, then the sum of  $G$  and the conjugate of  $H$  is a normal  $\mathcal{P}$ -position and, as  $G$  is equivalent to itself,  $G + \overline{G}$  is always a normal  $\mathcal{P}$ -position, which is actually easy to prove by mimicking the first player's move as the second player.

In normal play, finding the outcome of a game is the same as finding how it is compared to 0:

$$\left\{ \begin{array}{l} G \text{ is a } \mathcal{P}\text{-position if } G \equiv^+ 0 : G \text{ is zero} \\ G \text{ is an } \mathcal{L}\text{-position if } G >^+ 0 : G \text{ is positive} \\ G \text{ is an } \mathcal{R}\text{-position if } G <^+ 0 : G \text{ is negative} \\ G \text{ is an } \mathcal{N}\text{-position if } G \parallel^+ 0 : G \text{ is fuzzy} \end{array} \right.$$

For example, 0 is zero, 1 is positive,  $\overline{1}$  is negative, and  $*$  is fuzzy.

As  $G + \overline{G} \equiv^+ 0$  for any game  $G$ , we call the conjugate of a game  $G$  the *negative* of  $G$  and denote it  $-G$  in normal play.

We remind the reader that the order is only partial, in both conventions, and many pairs of games are incomparable, such as 0 and  $*$ .

Siegel showed [38] that if two games are comparable in misère play, they are comparable in normal play as well, in the same order, namely:

**Theorem 1.1 (Siegel [38])** *If  $G \geq^- H$ , then  $G \geq^+ H$ .*

However, the converse is not true, as  $\{*\mid*\} \equiv^+ 0$  and  $\{*\mid*\} \equiv^- 0$ .

Some options are considered irrelevant, either because there is a better move or because the answer of the opponent is ‘predictable’. We give here the definition of these options, omitting the superscripts  $+$  and  $-$ , as they are defined the same way for normal play and misère play.

**Definition 1.2 (dominated and reversible options)**

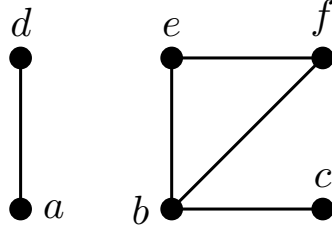
Let  $G$  be a game.

- (a) A Left option  $G^L$  is dominated by some other Left option  $G^{L'}$  if  $G^{L'} \geq G^L$ .
- (b) A Right option  $G^R$  is dominated by some other Right option  $G^{R'}$  if  $G^{R'} \leq G^R$ .
- (c) A Left option  $G^L$  is reversible through some Right option  $G^{LR}$  if  $G^{LR} \leq G$ .
- (d) A Right option  $G^R$  is reversible through some Left option  $G^{RL}$  if  $G^{RL} \geq G$ .

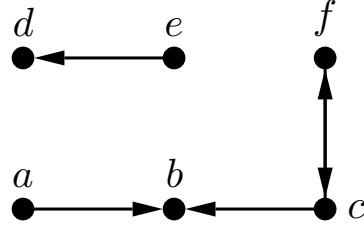
In both normal and misère play, a game is said to be in canonical form if none of its options is dominated or reversible and all its options are in canonical form, and every game is equivalent to a single game in canonical form [4, 10, 38]. To get to this canonical form, one may use two different operations corresponding to the status of the option they want to get rid of:

- Whenever  $G^{L_1}$  is dominated, removing  $G^{L_1}$  leaves an equivalent game:  $G \equiv \{G^L \setminus \{G^{L_1}\} \mid G^R\}$
- Whenever  $G^{R_1}$  is dominated, removing  $G^{R_1}$  leaves an equivalent game:  $G \equiv \{G^L \mid G^R \setminus \{G^{R_1}\}\}$
- Whenever  $G^{L_1}$  is reversible through  $G^{L_1 R_1}$ , bypassing  $G^{L_1}$  leaves an equivalent game:  $G \equiv \{(G^L \setminus \{G^{L_1}\}) \cup G^{L_1 R_1 L} \mid G^R\}$
- Whenever  $G^{R_1}$  is reversible through  $G^{R_1 L_1}$ , bypassing  $G^{R_1}$  leaves an equivalent game:  $G \equiv \{G^L \mid (G^R \setminus \{G^{R_1}\}) \cup G^{R_1 L_1 R}\}$

Theorem 1.1 implies that if an option is dominated (resp. reversible) in misère play, it is also dominated (resp. reversible) in normal play. Again, the converse is not true: in  $\{\{*\mid*\}, 0 \mid \{*\mid*\}, 0\}$ , all options are dominated in normal play, but none is dominated in misère play; in  $\{*\mid*\}$ , both options are reversible in normal play, but none is reversible in misère play. This implies that the normal canonical form of a game and its misère canonical form may be different:  $\{*\mid*\}$  is in misère canonical form, whereas its normal canonical form is 0.



**Figure 1.3:** The undirected graph with vertex set  $\{a, b, c, d, e, f\}$  and edge set  $\{(a, d), (b, c), (b, e), (b, f), (e, f)\}$



**Figure 1.4:** The directed graph with vertex set  $\{a, b, c, d, e, f\}$  and arc set  $\{(a, b), (c, b), (c, f), (e, d), (f, c)\}$

### 1.1.2 Graphs

A *graph*  $G$  consists of a set of *vertices*  $V(G)$  and a multiset of *edges*  $E(G)$  representing a symmetric binary relation between the vertices. As the relation is symmetric, the edge between two vertices  $u$  and  $v$  will be represented by  $(u, v)$  or  $(v, u)$  and the multiplicity of the edge between  $u$  and  $v$  is the sum of the multiplicity of these edges in the multiset  $E(G)$ . We say a graph is *simple* if the relation represented by  $E(G)$  is irreflexive and  $E(G)$  is a set, that is if no vertex is in relation with itself and the multiplicity of each edge is (0 or) 1. A *directed graph*  $G$  is a generalisation of a graph, such that the relation represented by  $E(G)$  no longer needs to be symmetric. We sometimes note  $A(G)$  rather than  $E(G)$  when  $G$  is a directed graph, and we call *directed edges* or *arcs* the elements of  $A(G)$ . The *underlying undirected graph*  $und(G)$  of a directed graph  $G$  is the graph obtained by considering arcs as edges, that is  $V(und(G)) = V(G)$  and  $E(und(G)) = \{(u, v) | (u, v) \in A(G) \text{ or } (v, u) \in A(G)\}$ . An *oriented graph* is a directed graph whose underlying undirected graph is a simple graph. An *orientation*  $\vec{G}$  of a graph  $G$  is a directed graph such that the underlying undirected graph of  $\vec{G}$  is  $G$ . The number of vertices  $|V(G)|$  of a graph  $G$  is called the *order* of  $G$ . A *subgraph*  $H$  of a graph  $G$  is a graph whose vertex set is a subset of  $V(G)$  and whose edge set is a subset of  $E(G)$ . An *induced subgraph*  $H$  of  $G$  is a subgraph of  $G$  such that  $E(H)$  is the restriction of  $E(G)$  to elements of  $V(H)$ . The graph induced by a set of vertices  $\{v_1 \cdots v_k\}$  of a graph  $G$  is the induced subgraph  $G[\{v_1 \cdots v_k\}]$  of  $G$  with vertex set  $\{v_1 \cdots v_k\}$ .

**Example 1.3** Figure 1.3 gives an example of a graph. The graph is simple as the multiplicity of each edge is at most one. Figure 1.4 gives an example of a directed graph. The directed graph is simple as the multiplicity of each edge is at most one. Nevertheless, it is not an oriented graph as it contains both the arc  $(c, f)$  and the arc  $(f, c)$ .

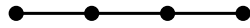
A *path*  $(v_1 \cdots v_n)$  of a graph  $G$  is a list of vertices of  $G$  such that for any  $i$  in  $\llbracket 2; n \rrbracket$ ,  $(v_{i-1}, v_i)$  is an edge of  $G$ . A *directed path*  $(v_1 \cdots v_n)$  of a directed graph  $G$  is a list of vertices of  $G$  such that for any  $i$  in  $\llbracket 2; n \rrbracket$ ,  $(v_{i-1}, v_i)$  is an arc of  $G$ . We say that  $(n - 1)$  is the *length* of the path, and that the path is from  $v_1$  to  $v_n$ . A *cycle*  $(v_1 \cdots v_n)$  of a graph  $G$  is a path of  $G$  such that  $(v_n, v_1) \in E(G)$ . A *circuit*  $(v_1 \cdots v_n)$  of a directed graph  $G$  is a directed path of  $G$  such that  $(v_n, v_1) \in A(G)$ . We also say that  $n$  is the length of the cycle. A path or cycle is said to be *simple* if all its vertices are pairwise distinct. A graph is said to be *connected* if for any pair  $u, v$  of vertices, there exists a path from  $u$  to  $v$ . A *connected component* of a graph  $G$  is a maximal connected subgraph of  $G$ . A directed graph is said to be *strongly connected* if for any pair  $u, v$  of vertices, there exists a directed path from  $u$  to  $v$  and a directed path from  $v$  to  $u$ . A *strongly connected component* of a directed graph  $G$  is a maximal strongly connected subgraph of  $G$ . A connected component of a directed graph  $G$  is a connected component of  $\text{und}(G)$ . The *distance*  $d(u, v)$  between two vertices  $u$  and  $v$  in a graph  $G$  is the length of the shortest path between  $u$  and  $v$  in  $G$  if such a path exists, and infinite otherwise.

**Example 1.4** Figure 1.5 gives an example of a path. Figure 1.6 gives an example of a cycle. We can see that both graphs are connected. Figure 1.7 is an example of a non-connected graph having three connected components: there is no path from  $a$  to  $b$  or to  $c$ , and there is none either from  $b$  to  $c$ . Figure 1.8 is an example of a strongly-connected directed graph: given any two vertices of the directed graph, one only needs to follow the grey arcs from one to the other.

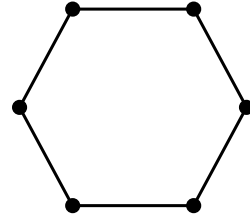
A *subdivision* of a graph  $G$  is a graph obtained from  $G$  by replacing some edges by paths of any length. The *intersection graph* of a graph  $G$  is the subdivision of  $G$  such that each edge of  $G$  has been replaced by a path with two edges.

**Example 1.5** Figure 1.9 gives an example of a graph (on the left) and its intersection graph (on the right). Every edge of the first graph has been replaced by a vertex incident to both ends of that edge.

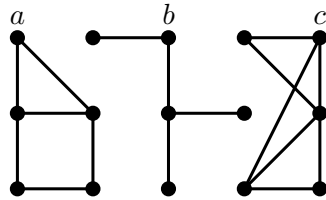
A *neighbour*  $u$  of a vertex  $v$  in a graph  $G$  is a vertex such that  $(u, v) \in E(G)$ . When  $u$  is a neighbour of  $v$ , we say  $u$  and  $v$  are *adjacent*. The *neighbourhood*  $N(v)$  of a vertex  $v$  is the set of all neighbours of  $v$ . The *closed neighbourhood*  $N[v]$  of a vertex  $v$  is the set  $N(v) \cup \{v\}$ . The *degree*  $d_G(v)$  (or  $d(v)$ ) of a vertex  $v$  in a graph  $G$  is the number of its neighbours. An *in-neighbour* of a vertex  $v$  in a directed graph  $G$  is a vertex  $u$  such that  $(u, v) \in E(G)$ . An *out-neighbour* of a vertex  $u$  in a directed graph  $G$  is a vertex  $v$  such that  $(u, v) \in E(G)$ . We say  $(u, v)$  is an *out-arc* of  $u$  and an *in-arc* of  $v$ . The *in-degree*  $d_G^-(v)$  (or  $d^-(v)$ ) of a vertex  $v$  in a directed graph  $G$  is the number of its in-neighbours. The *out-degree*  $d_G^+(v)$  (or  $d^+(v)$ ) of



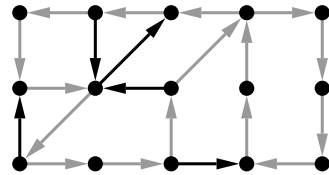
**Figure 1.5:** The path on four vertices



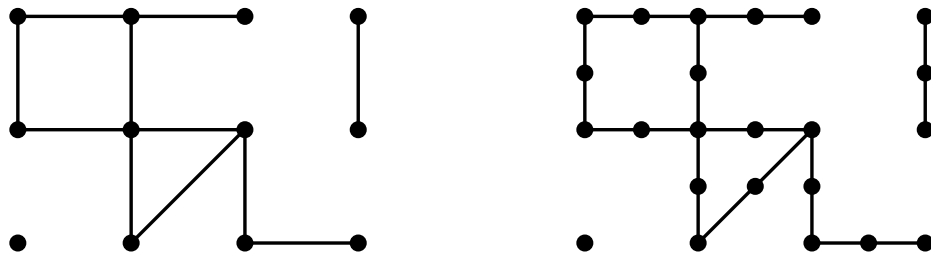
**Figure 1.6:** The cycle on six vertices



**Figure 1.7:** A graph with three connected components

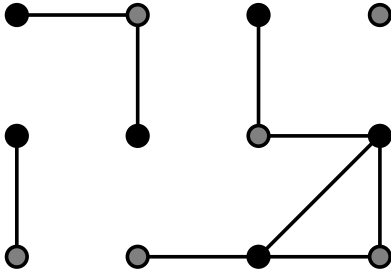


**Figure 1.8:** A strongly connected directed graph

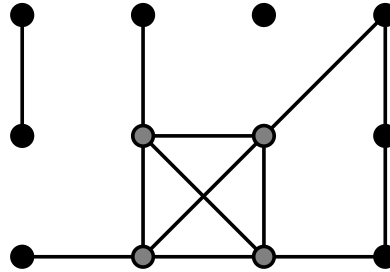


**Figure 1.9:** A graph and its intersection graph





**Figure 1.10:** An independent set of a graph



**Figure 1.11:** A clique of a graph

a vertex  $v$  in a directed graph  $G$  is the number of its out-neighbours. The degree  $d_G(v)$  (or  $d(v)$ ) of a vertex  $v$  in a directed graph  $G$  is the sum of its in-degree and its out-degree.

An *independent set* is a set of vertices inducing a graph with no edge. A *clique* is a set of vertices inducing a graph where any pair of vertices forms an edge. A *proper colouring* of a graph  $G$  over a set  $S$  is a function  $c : V(G) \rightarrow S$  such that for any element  $i$  of  $S$ ,  $c^{-1}(i)$  is an independent set. A *partial proper colouring* of a graph  $G$  is a proper colouring of an induced subgraph of  $G$ . A bipartite graph is a graph admitting a proper colouring over a set of size 2. A planar graph is a graph one can draw on the plane without having edges crossing each other.

**Example 1.6** In Figure 1.10, the grey vertices form an independent set of the graph: they are pairwise not adjacent. In Figure 1.11, the grey vertices form a clique of the graph: they are pairwise adjacent.

The *complement*  $\overline{G}$  of a simple graph  $G$  is the graph with vertex set  $V(\overline{G}) = V(G)$  and edge set  $E(\overline{G}) = \{(u, v) \mid u, v \in V(G), u \neq v, (u, v) \notin E(G)\}$ . The *disjoint union*  $G \cup H$  of two graphs  $G$  and  $H$  (having disjoint sets of vertices, that is  $V(G) \cap V(H) = \emptyset$ ) is the graph with vertex set  $V(G \cup H) = V(G) \cup V(H)$  and edge set  $E(G \cup H) = E(G) \cup E(H)$ . The *join*  $G \vee H$  of two graphs  $G$  and  $H$  is the graph with vertex set  $V(G \vee H) = V(G) \cup V(H)$  and edge set  $E(G \vee H) = E(G) \cup E(H) \cup \{(u, v) \mid u \in V(G), v \in V(H)\}$ . The disjoint union and the join operations are extended to more than two graphs, iteratively, as the operation is both commutative and associative. The *Cartesian product*  $G \square H$  of two graphs  $G$  and  $H$  is the graph with vertex set  $V(G \square H) = \{(u, v) \mid u \in V(G), v \in V(H)\}$  and edge set

$$E(G \square H) = \{((u_1, v_1), (u_2, v_2)) \mid (u_1 = u_2 \text{ and } (v_1, v_2) \in E(H)) \\ \text{or } (v_1 = v_2 \text{ and } (u_1, u_2) \in E(G))\}.$$

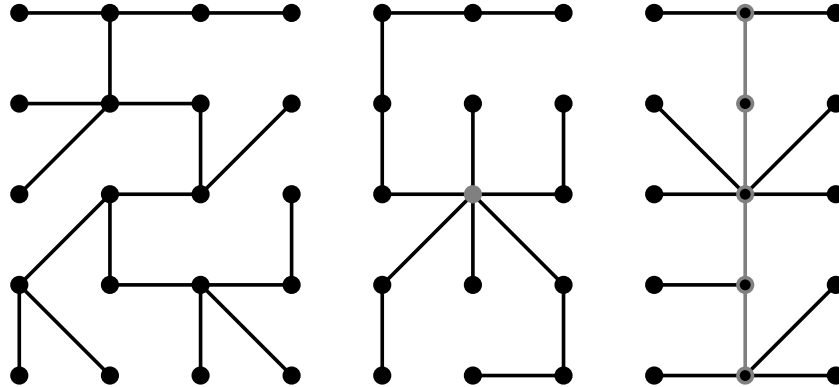


Figure 1.12: A forest of three trees

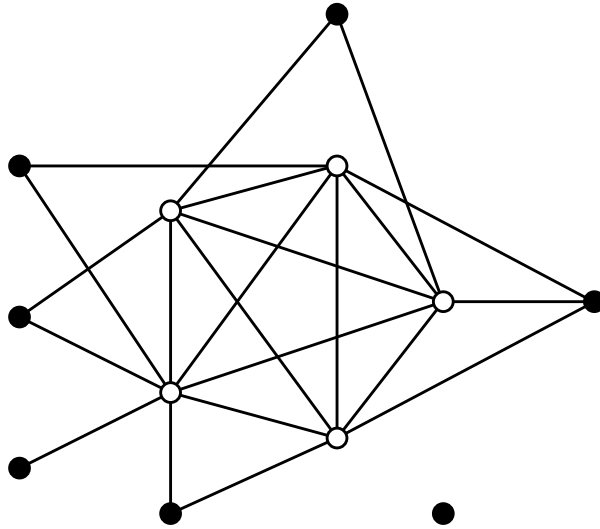
**Example 1.7** The complement of an independent set is a clique, and vice versa. The join of  $n$  vertices is a clique. The disjoint union of  $n$  vertices is an independent set. The complement of the join of  $k$  graphs is the disjoint union of the complements of these graphs. The Cartesian product of two single edges is a cycle on four vertices.

A *tree* is a connected graph with no cycle. A *forest* is a graph with no cycle. A *star* is a tree where all vertices but one have degree 1. That vertex with higher degree is called the *center* of the star. A *subdivided star* is any subdivision of a star. A *caterpillar* is a tree such that the set of vertices of degree at least 2 forms a path. A *rooted tree* is a tree with a special vertex, called the *root* of the tree. In a rooted tree, a vertex  $u$  is a *child* of a vertex  $v$  if  $u$  and  $v$  are adjacent and the distance between  $u$  and the root is greater than the distance between  $v$  and the root; in this case, we say  $v$  is a *parent* of  $u$ . In a tree, a vertex of degree 1 is called a *leaf*, and any other vertex is called an *internal node*.

**Example 1.8** Figure 1.12 is an example of a forest. As in any forest, each connected component is a tree. The middle one is a subdivided star, where the grey vertex is the center. The right one is a caterpillar, where the vertices of degree at least two are circled in grey, while the edges connecting them are grey too, highlighting the fact they form a path.

A *split graph* is a graph whose vertex set can be partitioned into a clique and an independent set. The adjacency relation between these two sets might be anything.

**Example 1.9** Figure 1.13 gives an example of a split graph. The white vertices induce a clique, and the black vertices induce an independent set.



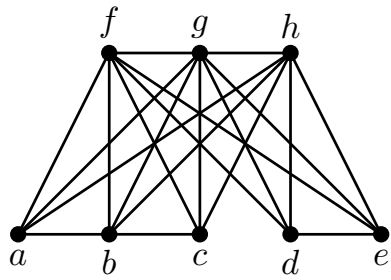
**Figure 1.13:** A split graph

The set of *cographs* is defined recursively as follows: the graph with one vertex and no edge is a cograph; if  $G$  and  $H$  are cographs, then  $G \cup H$  and  $G \vee H$  are cographs.

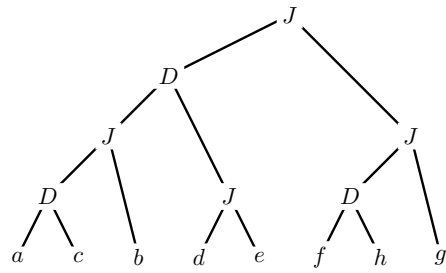
Given a rooted tree with all internal nodes labelled  $D$  or  $J$ , going from the leaves to the root, we can associate to each node of the tree a graph as follows: a leaf is associated to a single vertex; a node labelled  $D$  is associated to the disjoint union of its children; and a node labelled  $J$  is associated to the join of its children.

A *cotree* of a cograph is a labelled rooted tree such that: the leaves correspond to the vertices of the cograph; the internal nodes are labelled  $D$  or  $J$ ; and the graph associated to the root is the cograph.

**Example 1.10** Figure 1.14 gives an example of a cograph, while Figure 1.15 gives a cotree associated with the cograph of Figure 1.14. The root is the  $J$  vertex on the top. The two vertices labelled  $J$  on the right of the cotree could be merged (into the root), but this is not necessary.



**Figure 1.14:** A cograph



**Figure 1.15:** An associated cotree

## Chapter 2

# Impartial games

**I**mpartial games are a subset of games in which the players are not distinguished, that is they both have the same set of moves through the whole game. More formally, a game  $G$  is said to be impartial if  $G^L = G^R$  and all its options are impartial.

As the players are not distinguished, the only possible outcomes are  $\mathcal{N}$  and  $\mathcal{P}$  (the only difference between the players is who plays first). When we deal with impartial games only, we refer to the first player as she and the second player as he.

Sprague [41, 42] and Grundy [19] showed independently that any impartial position is equivalent in normal play to a NIM position on a single heap. The size of such a heap is unique, which induces a function on positions that is called the Grundy-value and is noted  $g$ . An impartial game has outcome  $\mathcal{P}$  if and only if its Grundy-value is 0. The Grundy-value of a game is the minimum non-negative integer that is not the Grundy-value of any option of this game. The purpose of the Grundy-value is to give additional information compared to the outcome. It is actually sufficient to know the Grundy-values of two games to determine the Grundy-value of their sum:

$$g(G + H) = g(G) \oplus g(H)$$

where  $\oplus$  is the XOR of integers (sum of numbers in binary without carrying). That operation is also called the Nim-sum of two integers. It is known that  $g(G) = g(H) \Leftrightarrow G \equiv^+ H$  when  $G$  and  $H$  are both impartial games (the Grundy-value is not defined on partizan games), and two impartial games having different Grundy-values are incomparable.

The impartial games we will present in this chapter are called VERTEXNIM and TIMBER. Both games are played on directed graphs, though VERTEXNIM is played on weighted directed graphs whereas having weights would be irrelevant when playing TIMBER. In Section 2.1, we define the game VERTEXNIM and give polynomial-time algorithms for finding the normal outcome of directed graphs with a self loop on every vertex and undirected graphs where the self-loops are optional. In Section 2.2, we define the game TIMBER, show how to reduce any position to a forest and give polynomial-time algorithms for finding the normal outcome of connected directed graphs and oriented forests of paths.

The results presented in Section 2.1 are about to appear in [16] (joint work with Éric Duchêne), and those presented in Section 2.2 appeared in [29] (joint work with Richard Nowakowski, Emily Lamoureux, Stephanie Mellon and Timothy Miller).

---

<b>2.1</b>	<b>VERTEXNIM</b>	<b>14</b>
2.1.1	Directed graphs	16
2.1.2	Undirected graphs	21
<b>2.2</b>	<b>TIMBER</b>	<b>26</b>
2.2.1	General results	27
2.2.2	Trees	32
<b>2.3</b>	<b>Perspectives</b>	<b>40</b>

---



---

## 2.1 VERTEXNIM

---

VERTEXNIM is an impartial game played on a weighted strongly-connected directed graph with a token on a vertex. On a move, a player decreases the weight of the vertex where the token is and slides the token along a directed edge. When the weight of a vertex  $v$  is set to 0,  $v$  is removed from the graph and all the pairs of arcs  $(p, v)$  and  $(v, s)$  (with  $p$  and  $s$  not necessarily distinct) are replaced by an arc  $(p, s)$ .

A position is described by a triple  $(G, w, u)$ , where  $G$  is a directed graph,  $w$  a function from  $V(G)$  to positive integers and  $u$  a vertex of  $G$ .

**Example 2.1** Figure 2.1 gives an example of a move. The token is on the grey vertex. The player whose turn it is chooses to decrease the weight of this vertex from 5 to 2 and slide the token through the arc to the right. They could have slid it through the arc to the left, but through no other arc.

**Example 2.2** Figure 2.2 is an example of a move which sets a vertex to 0. The token is on the grey vertex. The player whose turn it is chooses to decrease the weight of this vertex from 2 to 0 and move the token through the arc to the right. New arcs are added from the bottom left vertex and middle right vertex to the bottom middle vertex, top middle vertex and middle right vertex, creating a self loop on the middle right vertex.

VERTEXNIM can also be played on a connected undirected graph  $G$  by seeing it as a symmetric directed graph where the vertex set remains the same and the arc set is  $\{(u, v), (v, u) \mid (u, v) \in E(G)\}$ .

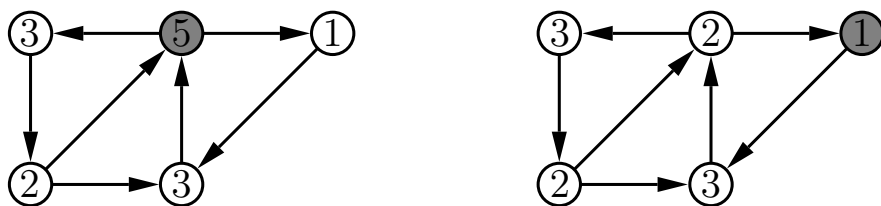


Figure 2.1: Playing a move in VERTEXNIM

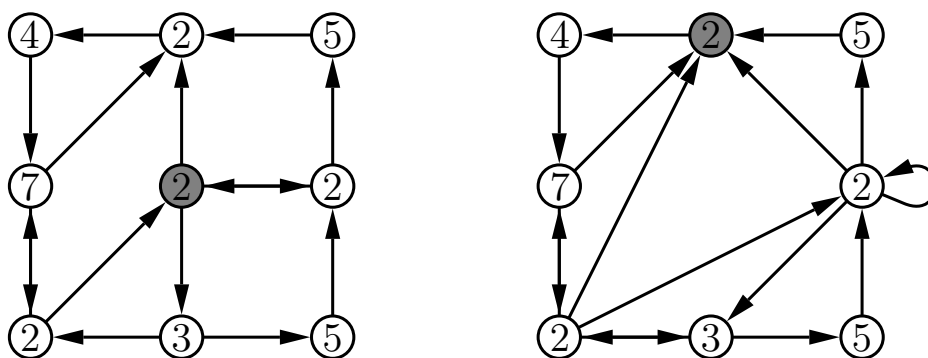


Figure 2.2: Setting a vertex to 0 in VERTEXNIM

VERTEXNIM can be seen as a variant of the game VERTEX NIMG (see [43]), where the players cannot put the token on a vertex with weight 0 and instead continue to move it until it reaches a vertex with positive weight, though we only consider the *Remove then move* version.

Multiple arcs are irrelevant, so we can consider we are only dealing with simple directed graphs.

**Example 2.3** Figure 2.3 shows an execution of the game. The token is on the grey vertex and the player whose turn it is moves it through the grey arc. After 11 moves, all weights are set to 0, so the player who started the game wins. Be careful that it does not mean the starting position is an  $\mathcal{N}$ -position, as the second player might have better moves to choose at some point in the game.

In this section, we present algorithms to find the outcome of any directed graph with a self loop on every vertex and the outcome of any undirected graph.

### 2.1.1 Directed graphs

On a circuit, without any loop, the game is called ADJACENT NIM. We first analyse the case when the graph is a circuit and no vertex has weight 1, that is  $w^{-1}(1) = \emptyset$ . If the length of the circuit is odd, the first player can reduce the weight of the first vertex to 1 then “copy” the moves of the second player (reducing the weight of the vertex to 0 if he just did the same, and reducing the weight to 1 otherwise) to force him to play on the vertices she leaves him in a way so that he is forced to empty them (because she left the weight as 1), breaking the “symmetry” on the last vertex to save the last move for her. When the length of the circuit is even, a player who would empty a vertex while no 1 has appeared would get themselves in the position of a second player on an odd circuit, so it is never a good move and the two players will play on distinct sets of vertices until a vertex is lowered to 1. Actually, we will see that getting the weight of a vertex to 1 is not good either, so the minimum weight of the vertices decides the winner.

**Theorem 2.4** *Let  $(C_n, w, v_1) : n \geq 3$  be an instance of VERTEXNIM with  $C_n$  the circuit of length  $n$  and  $w : V \rightarrow \mathbb{N}_{>1}$ .*

- *If  $n$  is odd, then  $(C_n, w, v_1)$  is an  $\mathcal{N}$ -position.*
- *If  $n$  is even, then  $(C_n, w, v_1)$  is an  $\mathcal{N}$ -position if and only if the smallest index of a vertex of minimum weight, that is  $\min_{1 \leq i \leq n} \{ \text{argmin } w(v_i) \}$ , is even.*

Note that when  $n$  is even, the above Theorem implies that the first player who must play on a vertex of minimum weight will lose the game.

**Proof.**



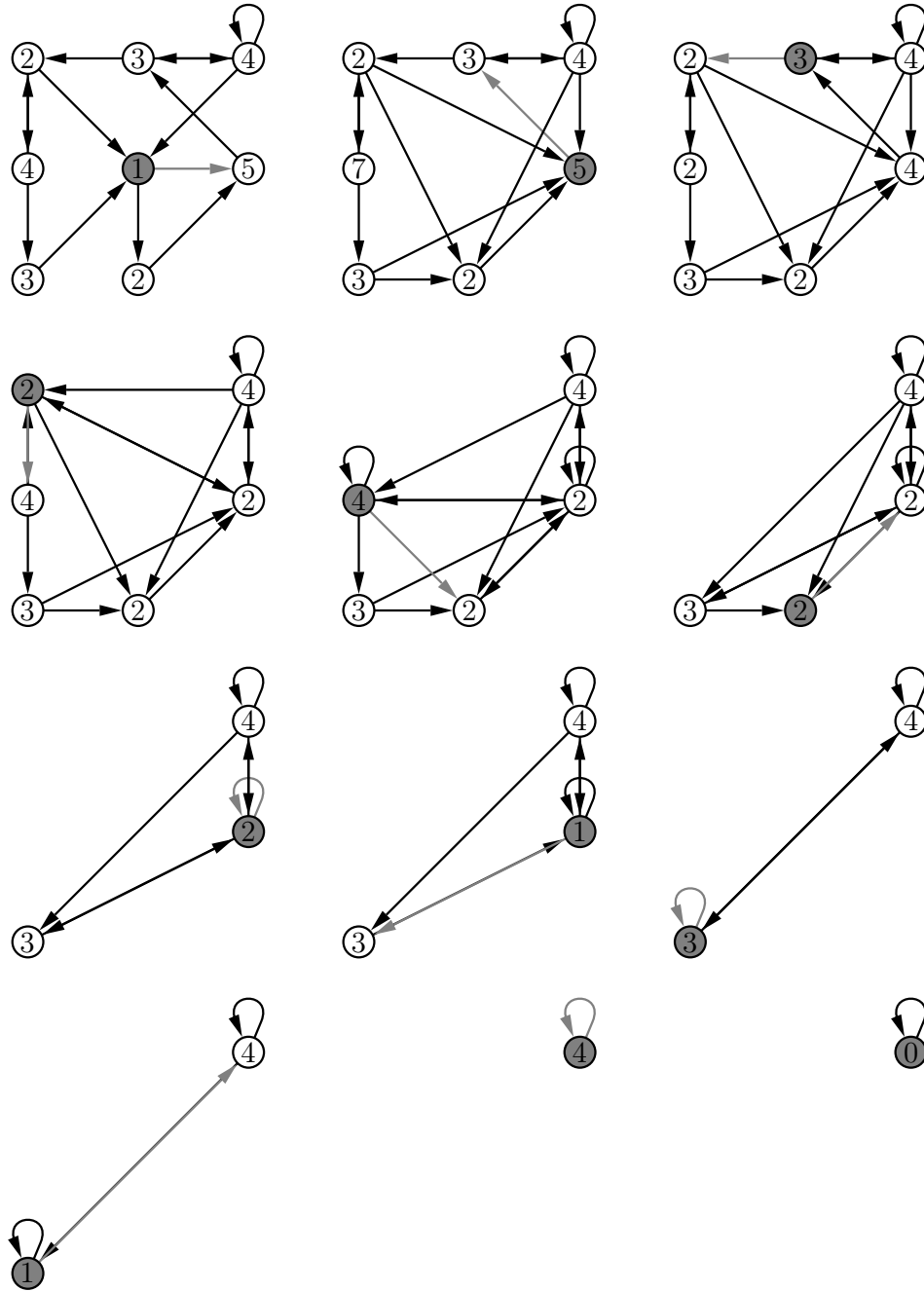


Figure 2.3: Playing VERTEXNIM, the token being on the grey vertex

- *Case (1)* If  $n$  is odd, then the first player can apply the following strategy to win: first, she plays  $w(v_1) \rightarrow 1$ . Then for all  $1 \leq i < \frac{n-1}{2}$ : if the second player empties  $v_{2i}$ , then the first player also empties the following vertex  $v_{2i+1}$ . Otherwise, she sets  $w(v_{2i+1})$  to 1. The strategy is different for the last two vertices of  $C_n$ : if the second player empties  $v_{n-1}$ , then she plays  $w(v_n) \rightarrow 1$ , otherwise she plays  $w(v_n) \rightarrow 0$ . As  $w(v_1) = 1$ , the second player is now forced to empty  $v_1$ . Since an even number of vertices have been deleted at this point, we have an odd circuit to play on. It now suffices for the first player to empty all the vertices on the second run. Indeed, the second player is also forced to set each weight to 0 since he has to play on vertices having their weight equal to 1. Since the circuit is odd, the first player is guaranteed to make the last move on  $v_n$  or  $v_{n-1}$ .
- *Case (2)* If  $n$  is even, we claim that who must play the first vertex of minimum weight will lose the game. The winning strategy of the other player consists in decreasing by 1 the weight of each vertex at their turn. First assume that  $\min_{1 \leq i \leq n} \{\operatorname{argmin} w(v_i)\}$  is odd. If the strategy of the second player always consists in decreasing the weight of the vertices he plays on by 1, then the first player will be the first to set a weight to 0 or 1. If she sets a vertex to 0, then the second player now faces an instance  $(C'_{n-1}, w', v_i)$  with  $w' : V' \rightarrow \mathbb{N}_{>1}$ , which is winning according to the previous item. If she sets a vertex to 1, then the second player will empty the following vertex, leaving to the first player a position  $(C'_{n-1} = (v'_1, v'_2, \dots, v'_{n-1}), w', v'_2)$  with  $w' : V' \rightarrow \mathbb{N}_{>1}$  except on  $w'(v'_1) = 1$ . This position corresponds to the one of the previous item after the first move, and is thus losing. A similar argument shows that the first player has a winning strategy if  $\min_{1 \leq i \leq n} \{\operatorname{argmin} w(v_i)\}$  is even.

□

On a general strongly connected digraph, the problem seems harder. Nevertheless, we manage to find the outcome of a strongly connected digraph having the additional condition that every vertex has a self loop.

When the token is on a vertex with weight at least 2 and a self loop, we give a non-constructive argument that the game is an  $\mathcal{N}$ -position (though from the rest of the proof, we can deduce a winning move in polynomial time). Hence, when the token is on a vertex of weight 1, the aim of both players is to have the other player be the one that moves it to a vertex with weight at least 2. This is why we define a labelling of the vertices of the directed graph that indicates if the next player is on a good position to have her opponent eventually move the token to a vertex with weight at least 2.

**Definition 2.5** Let  $G$  be a directed graph. We define a labelling  $\text{lo}_G : V(G) \rightarrow \{\mathcal{P}, \mathcal{N}\}$  as follows :

Let  $S \subseteq V(G)$  be a non-empty set of vertices such that the graph induced by  $S$  is strongly connected and  $\forall u \in S, \forall v \in (V(G) \setminus S), (u, v) \notin E(G)$ .

Let  $T = \{v \in V(G) \setminus S \mid \exists u \in S, (v, u) \in E(G)\}$ .

Let  $G_e$  be the graph induced by  $V(G) \setminus S$  and  $G_o$  the graph induced by  $V(G) \setminus (S \cup T)$ .

If  $|S|$  is even, we label  $\mathcal{N}$  all elements of  $S$  and we label elements of  $V \setminus S$  as we would have labelled them in the graph  $G_e$ .

If  $|S|$  is odd, we label  $\mathcal{P}$  all elements of  $S$ , we label  $\mathcal{N}$  all elements of  $T$ , and we label elements of  $V \setminus (S \cup T)$  as we would have labelled them in the graph  $G_o$ .

When decomposing the graph into strongly connected components,  $S$  is one of those with no out-arc. The choice of  $S$  is not unique, unlike the  $\text{lo}_G$  function: if  $S_1$  and  $S_2$  are both strongly connected components without out-arcs, the one which is not chosen as the first set  $S$  will remain a strongly connected component after the removal of the other, and as it has no out-arc, none of its vertices will be in the  $T$  set.

The labelled graph does not need to be strongly connected in that definition as we will use it on the subgraph of our position induced by vertices of weight 1, where a path from some vertices might have to go through a vertex of bigger weight to reach some other vertices of weight 1.

**Example 2.6** Figure 2.4 gives the lo labelling of a directed graph. The sets  $S_i, T_i$  are pointed out to give the order in which we consider them. Note that several orders are possible, but all return the same labelling. All vertices belonging to  $S_1$  are labelled  $\mathcal{N}$  because the size of  $S_1$  is even. As such,  $T_1$  is considered empty even though there are vertices having out-neighbours in  $S_1$ . All vertices belonging to  $S_5$  are labelled  $\mathcal{P}$  because the size of  $S_5$  is odd. As such, the two vertices belonging to  $T_5$  (because they are unlabelled at that time and have an outneighbour in  $S_5$ ) are labelled  $\mathcal{N}$ .

We now give the algorithm for finding the outcome of a strongly connected directed graph with a self loop on every vertex.

**Theorem 2.7** Let  $(G, w, u)$  be an instance of VERTEXNIM where  $G$  is strongly connected with a self loop on each vertex. Deciding whether  $(G, w, u)$  is  $\mathcal{P}$  or  $\mathcal{N}$  can be done in time  $O(|V(G)||E(G)|)$ .

**Proof.** Let  $G'$  be the induced subgraph of  $G$  such that  $V(G') = \{v \in V(G) \mid w(v) = 1\}$ .

If  $G = G'$ , then  $(G, w, u)$  is an  $\mathcal{N}$ -position if and only if  $|V(G)|$  is odd since the problem reduces to “She loves move, she loves me not”. We will now assume that  $G \neq G'$ , and consider two cases for  $w(u)$ :

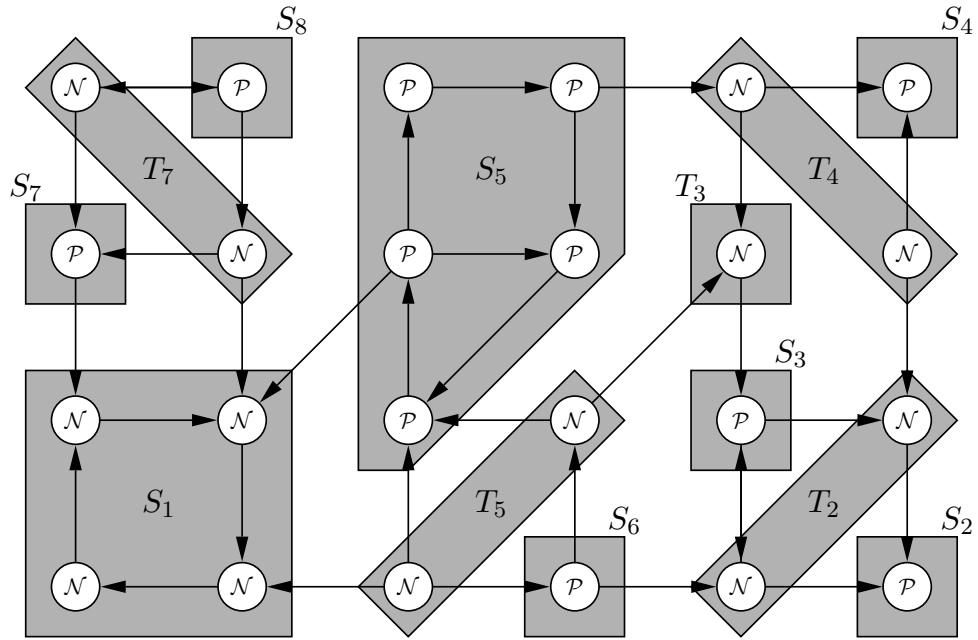


Figure 2.4: lo-labelling of a directed graph

- *Case (1)* Assume  $w(u) \geq 2$ . If there is a winning move which reduces the weight of  $u$  to 0, then we can play it and win. Otherwise, reducing the weight of  $u$  to 1 and staying on  $u$  is a winning move. Hence  $(G, w, u)$  is an  $\mathcal{N}$ -position.
- *Case (2)* Assume now  $w(u) = 1$ , i.e.,  $u \in G'$ . According to Definition 2.5, computing  $\text{lo}_{G'}$  yields a sequence of couples of sets  $(S_i, T_i)$  (which is not unique). Note that we do not consider  $T_i$  when  $S_i$  has an even size. Thus the following assertions hold: if  $u \in S_i$  for some  $i$ , then any direct successor  $v$  of  $u$  is either in the same component  $S_i$  (as there are no out-arc) or has been previously labelled (is in  $\cup_{j < i} (S_j \cup T_j)$ ), and if  $u \in T_i \neq \emptyset$  for some  $i$ , then there exists a direct successor  $v$  of  $u$  in the set  $S_i$ , with  $\text{lo}_{G'}(v) = \mathcal{P}$ .

Our goal is to show that  $(G, w, u)$  is an  $\mathcal{N}$ -position if and only if  $\text{lo}_{G'}(u) = \mathcal{N}$  by induction on  $|V(G')|$ . If  $|V(G')| = 1$ , then  $V(G') = \{u\}$  and  $\text{lo}_{G'}(u) = \mathcal{P}$ . Since  $w(u) = 1$ , we are forced to reduce  $u$  to 0 and go to a vertex  $v$  such that  $w(v) \geq 2$ , which we previously proved to be a losing move. Now assume  $|V(G')| \geq 2$ . First, note that when one reduces the weight of a vertex  $v$  to 0, the replacement of the arcs does not change the strongly connected components (except for the component containing  $v$  of course, which loses

one vertex). Consequently, if  $u \in S_i$  for some  $i$ , then for any vertex  $v \in \cup_{l=1}^{i-1} (T_l \cup S_l)$ ,  $\text{lo}_{G' \setminus \{u\}}(v) = \text{lo}_{G'}(v)$  and for any vertex  $w \in S_i \setminus \{u\}$ ,  $\text{lo}_{G' \setminus \{u\}}(w) \neq \text{lo}_{G'}(w)$  since parity of  $S_i$  has changed. If  $u \in T_i$  for some  $i$ , then for any vertex  $v \in (\cup_{l=1}^{i-1} (T_l \cup S_l)) \cup S_i$ ,  $\text{lo}_{G' \setminus \{u\}}(v) = \text{lo}_{G'}(v)$ .

We now consider two cases for  $u$ : first assume that  $\text{lo}_{G'}(u) = \mathcal{P}$ , with  $u \in S_i$  for some  $i$ . We reduce the weight of  $u$  to 0 and we are forced to move to a direct successor  $v$ . If  $w(v) \geq 2$ , we previously proved this is a losing move. If  $v \in \cup_{l=1}^{i-1} (T_l \cup S_l)$ , then  $\text{lo}_{G' \setminus \{u\}}(v) = \text{lo}_{G'}(v) = \mathcal{N}$  (if  $\text{lo}_{G'}(v) = \mathcal{P}$ , we would have  $v \in S_l$ , and so  $u \in T_l$ ) and it is a losing move by induction hypothesis. If  $v \in S_i$ , then  $\text{lo}_{G' \setminus \{u\}}(v) \neq \text{lo}_{G'}(v)$  and as  $\text{lo}_{G'}(v) = \mathcal{P}$ ,  $\text{lo}_{G' \setminus \{u\}}(v) = \mathcal{N}$  and the move to  $v$  is a losing move by induction hypothesis.

Now assume that  $\text{lo}_{G'}(u) = \mathcal{N}$ . If  $u \in T_i$  for some  $i$ , we can reduce the weight of  $u$  to 0 and move to a vertex  $v \in S_i$ , which is a winning move by induction hypothesis. If  $u \in S_i$  for some  $i$ , it means that  $|S_i|$  is even, we can reduce the weight of  $u$  to 0 and move to a vertex  $v \in S_i$ , with  $\text{lo}_{G' \setminus \{u\}}(v) \neq \text{lo}_{G'}(v) = \mathcal{N}$ . This is a winning move by induction hypothesis. Hence,  $(G, w, u)$  is an  $\mathcal{N}$ -position if and only if  $\text{lo}_{G'}(u) = \mathcal{N}$ . Figure 2.5 illustrates the computation of the lo function.

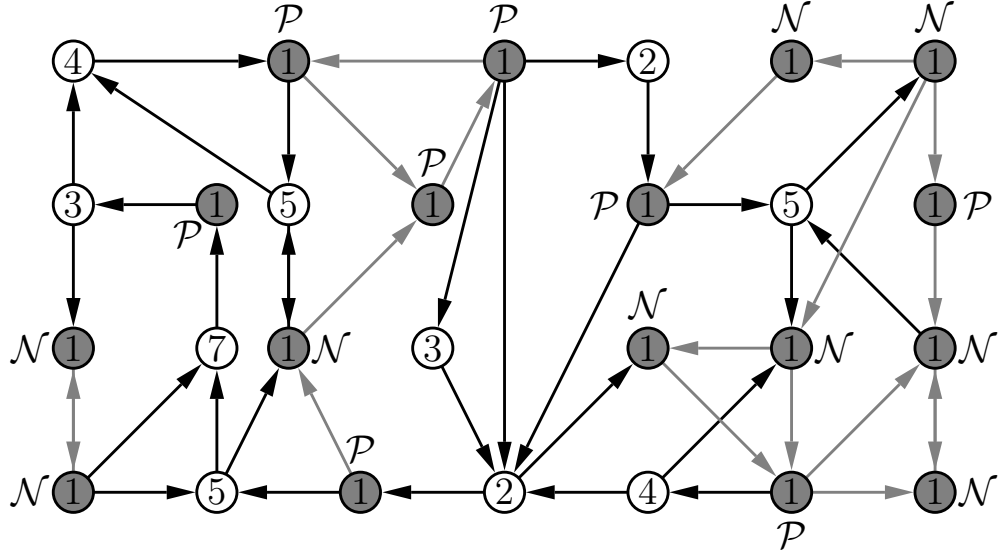
Concerning the complexity of the computation, note that when  $w(u) \geq 2$ , the algorithm answers in constant time. The computation of  $\text{lo}_{G'}(u)$  when  $w(u) = 1$  needs to be analysed more carefully. Decomposing a directed graph  $H$  into strongly connected components to find the sets  $S$  and  $T$  can be done in time  $O(|V(H)| + |E(H)|)$ , and both  $|V(H)|$  and  $|E(H)|$  are less than or equal to  $|E(G)|$  in our case since  $H$  is a subgraph of  $G$  and  $G$  is strongly connected. Moreover, the number of times we compute  $S$  and  $T$  is clearly bounded by  $|V(G)|$ . These remarks lead to a global algorithm running in  $O(|V(G)||E(G)|)$  time.  $\square$

The complexity of the problem on a general digraph where some of the vertices with weight at least 2 have no self loop is still open (remark that having a self loop on a vertex of weight 1 does not affect the game).

### 2.1.2 Undirected graphs

On undirected graphs with a self loop on each vertex, the computation of the labelling is easier since any connected component is “strongly connected”. Hence, the same algorithm gives a better complexity as the labelling of the subgraph induced by the vertices of weight 1 becomes linear.

**Proposition 2.8** *Let  $(G, w, u)$  be a VERTEXNIM position on an undirected graph such that there is a self loop on each vertex of  $G$ . Deciding whether  $(G, w, u)$  is  $\mathcal{P}$  or  $\mathcal{N}$  can be done in time  $O(|V(G)|)$ .*



**Figure 2.5:** lo-labelling function of a subgraph induced by vertices of weight 1 assuming every vertex has an undrawn self loop

**Proof.** Let  $G'$  be the induced subgraph of  $G$  such that  $V(G') = \{v \in V(G) \mid w(v) = 1\}$ .

If  $G = G'$ , then  $(G, w, u)$  is an  $\mathcal{N}$ -position if and only if  $|V(G)|$  is odd since the problem reduces to “She loves move, she loves me not”. In the rest of the proof, assume  $G \neq G'$ .

- *Case (1)* We first consider the case where  $w(u) \geq 2$ . If there is a winning move which reduces the weight of  $u$  to 0, then we play it and win. Otherwise, reducing the weight of  $u$  to 1 and staying on  $u$  is a winning move. Hence  $(G, w, u)$  is an  $\mathcal{N}$ -position.
- *Case (2)* Assume  $w(u) = 1$ . Let  $n_u$  be the number of vertices of the connected component of  $G'$  which contains  $u$ . We show that  $(G, w, u)$  is an  $\mathcal{N}$ -position if and only if  $n_u$  is even by induction on  $n_u$ . If  $n_u = 1$ , then we are forced to reduce the weight of  $u$  to 0 and move to another vertex  $v$  having  $w(v) \geq 2$ , which we previously proved to be a losing move. Now assume  $n_u \geq 2$ . If  $n_u$  is even, we reduce the weight of  $u$  to 0 and move to an adjacent vertex  $v$  with  $w(v) = 1$ , which is a winning move by induction hypothesis. If  $n_u$  is odd, then we reduce the weight of  $u$  to 0 and we are forced to move to an adjacent vertex  $v$ . If  $w(v) \geq 2$ , then we previously proved it is a losing move. If  $w(v) = 1$ , this is also a losing move by induction hypothesis. Therefore in that case,  $(G, w, u)$  is an  $\mathcal{N}$ -position if and only if  $n_u$  is even.

Concerning the complexity of the computation, note that when  $w(u) \geq 2$ , the algorithm answers in constant time. When  $w(u) = 1$ , we only need to find the connected component of  $G'$  containing  $u$  and its order, which can be done in  $O(|V(G)|)$  time. Thus, the algorithm runs in  $O(|V(G)|)$  time.  $\square$

We now focus on the general case where the self loops are optional. A vertex of weight at least 2 with a self loop is still a winning starting point for the same reason as in the previous studied cases, and lowering the weight of a vertex to 0 gives a self loop to all its neighbours because the graph is undirected, so the vertices of weight 1 are taken care of the same way as in the above proposition. We show how to decide the outcome of a position in the following theorem.

**Theorem 2.9** *Let  $(G, w, u)$  be a VERTEXNIM position on an undirected graph. Deciding whether  $(G, w, u)$  is  $\mathcal{P}$  or  $\mathcal{N}$  can be done in  $O(|V(G)||E(G)|)$  time.*

The proof of this theorem requires several definitions that we present here.

**Definition 2.10** *Let  $G$  be an undirected graph with a weight function  $w : V \rightarrow \mathbb{N}_{>0}$  defined on its vertices.*

*Let  $S = \{u \in V(G) \mid \forall v \in V(G), w(u) \leq w(v)\}$ .*

*Let  $T = \{v \in V(G) \setminus S \mid \exists u \in S, (v, u) \in E(G)\}$ .*

*Let  $\tilde{G}$  be the graph induced by  $V(G) \setminus (S \cup T)$ .*

*We define a labelling  $\text{lu}_{G,w}$  of its vertices as follows :*

- $\forall u \in S, \text{lu}_{G,w}(u) = \mathcal{P}, \forall v \in T, \text{lu}_{G,w}(v) = \mathcal{N}$
- $\forall t \in V(G) \setminus (S \cup T), \text{lu}_{G,w}(t) = \text{lu}_{\tilde{G},w}(t)$ .

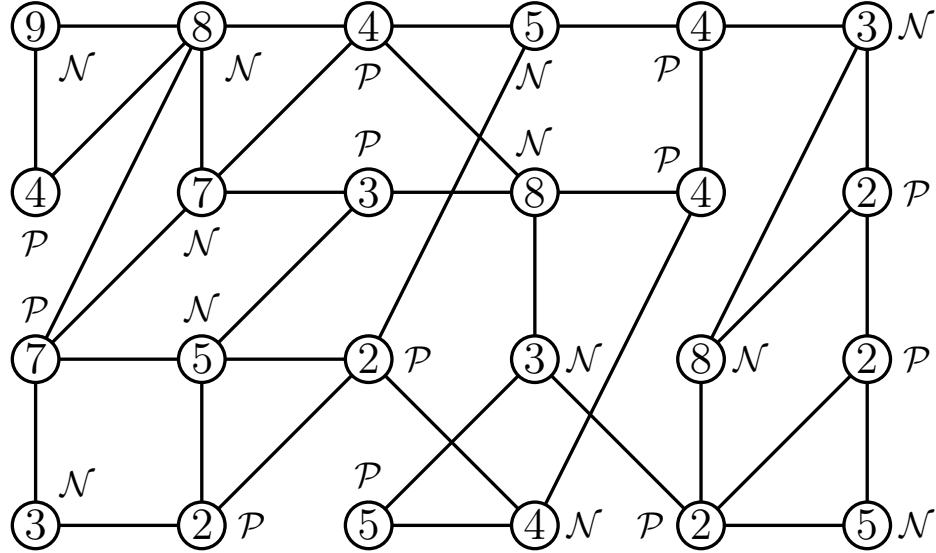
**Example 2.11** Figure 2.6 gives the lu labelling of an undirected weighted graph. The lowest weight is 2, so all the vertices having weight 2 are labelled  $\mathcal{P}$ . Then we know we can label all their unlabelled neighbours with  $\mathcal{N}$ .

**Proof.** Let  $G_u$  be the induced subgraph of  $G$  such that  $V(G_u) = \{v \in V(G) \mid w(v) = 1 \text{ or } v = u\}$ , and  $G'$  be the induced subgraph of  $G$  such that

$$V(G') = \{v \in V(G) \mid w(v) \geq 2 \\ (v, v) \notin E(G) \\ \forall t \in V(G), (v, t) \in E(G) \Rightarrow w(t) \geq 2\}.$$

If  $G = G_u$  and  $w(u) = 1$ , then  $(G, w, u)$  is an  $\mathcal{N}$ -position if and only if  $|V(G)|$  is odd since it reduces to “She loves move, she loves me not”.

If  $G = G_u$  and  $w(u) \geq 2$ , we reduce the weight of  $u$  to 0 and move to any vertex if  $|V(G)|$  is odd, and we reduce the weight of  $u$  to 1 and move to any vertex if  $|V(G)|$  is even; both are winning moves, hence  $(G, w, u)$  is an  $\mathcal{N}$ -position.

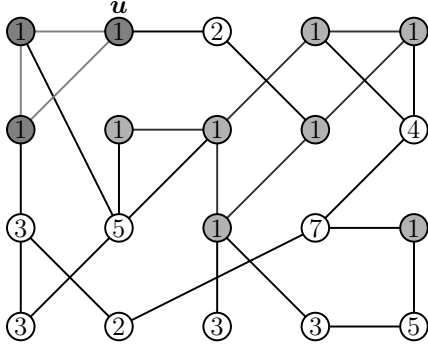


**Figure 2.6:** lu-labelling function of an undirected graph

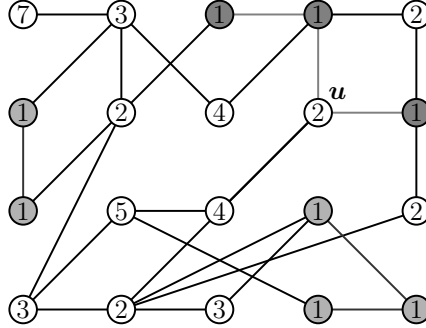
In the rest of the proof we will assume that  $G \neq G_u$ . In the first three cases, we assume  $u \notin G'$ .

- *Case (1)* Assume  $w(u) \geq 2$  and there is a loop on  $u$ . If there is a winning move which reduces the weight of  $u$  to 0, then we can play it and win. Otherwise, reducing the weight of  $u$  to 1 and staying on  $u$  is a winning move. Therefore  $(G, w, u)$  is an  $\mathcal{N}$ -position.
- *Case (2)* Assume  $w(u) = 1$ .  
Let  $n$  be the number of vertices of the connected component of  $G_u$  which contains  $u$ . We show that  $(G, w, u)$  is an  $\mathcal{N}$ -position if and only if  $n$  is even by induction on  $n$ . If  $n = 1$ , then we are forced to reduce the weight of  $u$  to 0 and move to another vertex  $v$ , with  $w(v) \geq 2$ , which was proved to be a losing move since it creates a loop on  $v$ . Now assume  $n \geq 2$ . If  $n$  is even, we reduce the weight of  $u$  to 0 and move to a vertex  $v$  satisfying  $w(v) = 1$ , which is a winning move by induction hypothesis (the connected component of  $G_u$  containing  $u$  being unchanged, apart from the removal of  $u$ ). If  $n$  is odd, we reduce the weight of  $u$  to 0 and move to some vertex  $v$ , creating a loop on it. If  $w(v) \geq 2$ , we already proved this is a losing move. If  $w(v) = 1$ , it is a losing move by induction hypothesis. We can therefore conclude that  $(G, w, u)$  is an  $\mathcal{N}$ -position if and only if  $n$  is even. Figure 2.7 illustrates this case.



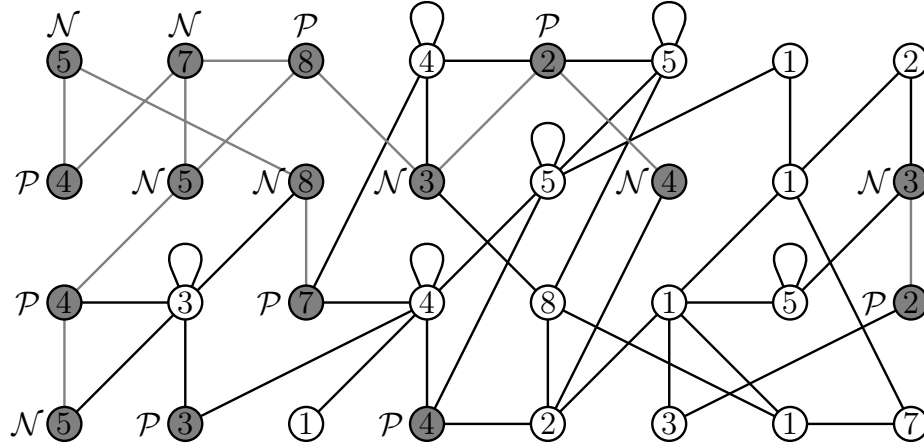


**Figure 2.7:** Case 2: the connected component containing  $u$  has an odd size: this is a  $\mathcal{P}$ -position as  $w(u) = 1$ .



**Figure 2.8:** Case 3: an  $\mathcal{N}$ -position since  $u$  of weight  $w(u) > 1$  has a neighbour of weight 1.

- *Case (3)* Assume  $w(u) \geq 2$  and there is a vertex  $v$  such that  $(u, v) \in E(G)$  and  $w(v) = 1$ . Let  $n$  be the number of vertices of the connected component of  $G_u$  which contains  $u$ . If  $n$  is odd, we reduce the weight of  $u$  to 1 and we move to  $v$ , which we proved to be a winning move. If  $n$  is even, we reduce the weight of  $u$  to 0 and we move to  $v$ , which we also proved to be winning. Hence  $(G, w, u)$  is an  $\mathcal{N}$ -position in that case. Figure 2.8 illustrates this case.
- *Case (4)* Assume now  $u \in G'$ . We show that  $(G, w, u)$  is  $\mathcal{N}$  if and only if  $\text{lu}_{G', w}(u) = \mathcal{N}$  by induction on  $\sum_{v \in V(G')} w(v)$ . If  $\sum_{v \in V(G')} w(v) = 2$ , we get  $G' = \{u\}$  and we are forced to play to a vertex  $v$  such that  $w(v) \geq 2$  and  $v \notin V(G')$ , which we proved to be a losing move. Assume  $\sum_{v \in V(G')} w(v) \geq 3$ . If  $\text{lu}_{G', w}(u) = \mathcal{N}$ , we reduce the weight of  $u$  to  $w(u) - 1$  and move to a vertex  $v$  of  $G'$  such that  $w(v) < w(u)$  and  $\text{lu}_{G', w}(v) = \mathcal{P}$ . Such a vertex exists by definition of  $\text{lu}$ . Let  $(G_1, w_1, v)$  be the resulting position after such a move. Hence  $\text{lu}_{G_1, w_1}(v) = \text{lu}_{G', w}(v) = \mathcal{P}$  since the only weight that has been reduced remains greater or equal to the one of  $v$ . And  $(G_1, w_1, v)$  is a  $\mathcal{P}$ -position by induction hypothesis. If  $\text{lu}_{G', w}(u) = \mathcal{P}$ , the first player is forced to reduce the weight of  $u$  and to move to some vertex  $v$ . Let  $(G_1, w_1, v)$  be the resulting position. First remark that  $w_1(v) \geq 2$  since  $u \in G'$ . If she reduces the weight of  $u$  to 0, she will lose since  $v$  now has a self loop. If she reduces the weight of  $u$  to 1, she will also lose since  $(u, v) \in E(G_1)$  and  $w_1(u) = 1$  (according to case (3)). Assume she reduced the weight of  $u$  to a number  $w_1(u) \geq 2$ . Thus  $\text{lu}_{G_1, w_1}(u)$  still equals  $\mathcal{P}$  since the only weight we modified is the one of  $u$  and it has been decreased. If  $v \notin G'$ , i.e.,  $v$  has a loop or there exists  $t \in V(G_1)$  such that  $(v, t) \in E(G_1)$  and  $w_1(t) = 1$ , then the second player wins according to cases (1) and (3). If  $v \in G'$  and



**Figure 2.9:** Case 4: lu-labelling of the subgraph  $G'$

$\text{lu}_{G',w}(v) = \mathcal{N}$ , then  $\text{lu}_{G'_1,w_1}(v)$  is still  $\mathcal{N}$  since the only weight we decreased is the one of a vertex labelled  $\mathcal{P}$  being a neighbour of  $u$ . Consequently the resulting position makes the second player win by induction hypothesis. If  $v \in G'$  and  $\text{lu}_{G',w}(v) = \mathcal{P}$ , then we necessarily have  $w(v) = w(u)$  in  $G'$ . As  $\text{lu}_{G'_1,w_1}(u) = \mathcal{P}$  and  $(u, v) \in E(G_1)$ , then  $\text{lu}_{G'_1,w_1}(v)$  becomes  $\mathcal{N}$ , implying that the second player wins by induction hypothesis. Hence  $(G, w, u)$  is  $\mathcal{N}$  if and only if  $\text{lu}_{G',w}(u) = \mathcal{N}$ . Figure 2.9 shows an example of the  $lu$  labelling.

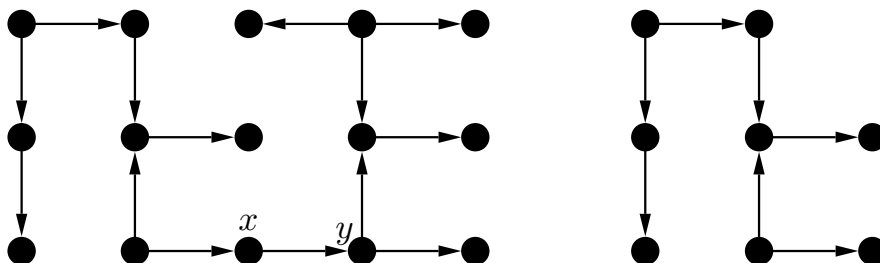
Concerning the complexity of the computation, note that all the cases except (4) can be executed in  $O(|E(G)|)$  operations. Hence the computation of  $\text{lu}_{G',w}(u)$  to solve case (4) becomes crucial. We just need to compute the strongly connected component and the associated directed acyclic graph to compute  $S$  and  $T$ , so in the worst case, it can be done in  $O(|E(G)|)$  time. And the number of times where  $S$  and  $T$  are computed in the recursive definition of  $lu$  is clearly bounded by  $|V(G)|$ . All of this leads to a global algorithm running in  $O(|V(G)||E(G)|)$  time.  $\square$

---

## 2.2 TIMBER

---

TIMBER is an impartial game played on a directed graph. On a move, a player chooses an arc  $(x, y)$  of the graph and removes it along with all that is still connected to the endpoint  $y$  in the underlying undirected graph where the arc  $(x, y)$  has already been removed. Another way of seeing it is to put a vertical domino on every arc of the directed graph, and consider that if one domino is toppled, it topples the dominoes in the direction it was toppled and creates a chain reaction. The direction of the arc indicates the direction



**Figure 2.10:** Playing a move in TIMBER

in which the domino can be initially toppled, but has no incidence on the direction it is toppled, or on the fact that it is toppled, if a player has chosen to topple a domino which will eventually topple it.

The description of a position consists only of the directed graph on which the two players are playing. Note that it does not need to be strongly connected, or even connected.

**Example 2.12** Figure 2.10 gives an example of a move. The player whose move it is chooses to remove the arc  $(x, y)$ . The whole connected component containing  $y$  in the underlying undirected graph without the arc  $(x, y)$  is removed with it.

**Example 2.13** Figure 2.11 shows an execution of the game. On a given position, the player who is playing is choosing the dark grey arc, and all that will disappear along with it is coloured in lighter grey. The  $x_i$  and  $y_i$  indicate the endpoints of the chosen arc. After the fourth move, the graph is empty of arcs, so the game ends. Note that some games can end leaving several isolated vertices, as well as no vertex at all.

In this section, we present algorithms to find the normal outcome of any connected directed graph, and the Grundy-value of any orientation of paths.

### 2.2.1 General results

First, we see how to reduce the problem to orientations of forests: playing in a cycle removes the whole connected component, and playing on an arc going out of a degree-1 vertex leaves only that vertex in the component. In both cases there are no more move available in the component after they have been played, so it is natural to aim at reducing the former to the latter. The only issue is how to deal with the arcs which were going in and out the cycle. This is what we present in Theorem 2.14. Note that the cycle does not need to be induced, nor even elementary.

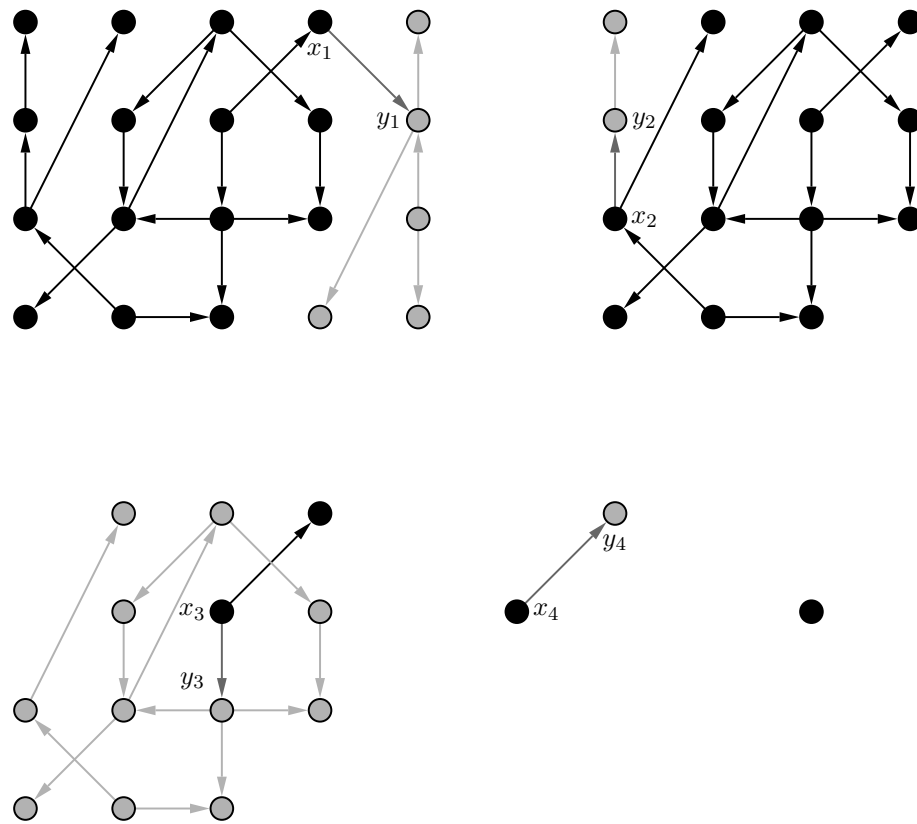


Figure 2.11: Playing TIMBER

**Theorem 2.14** *Let  $G$  be a directed graph seen as a TIMBER position such that there exists a set  $S$  of vertices that forms a 2-edge-connected component of  $G$ , and  $x, y$  two vertices not belonging to  $V(G)$ . Let  $G'$  be the directed graph with vertex set*

$$V(G') = (V(G) \setminus S) \cup \{x, y\}$$

and arc set

$$\begin{aligned} A(G') = & (A(G) \setminus \{(u, v) \mid \{u, v\} \cap S \neq \emptyset\}) \\ & \cup \{(u, x) \mid u \in (V(G) \setminus S), \exists v \in S, (u, v) \in A(G)\} \\ & \cup \{(x, u) \mid u \in (V(G) \setminus S), \exists v \in S, (v, u) \in A(G)\} \\ & \cup \{(y, x)\}. \end{aligned}$$

Then  $G =^+ G'$ .

**Proof.** Let  $H$  be any game such that Left has a winning strategy on  $G + H$  playing first (or second). On  $G' + H$ , she can follow the same strategy unless it recommends to choose an arc between elements of  $S$  or Right chooses the arc  $(y, x)$ . In the first case, she can choose the arc  $(y, x)$ , which is still on play since any move removing  $(y, x)$  in  $G'$  would remove all arc of  $S$  in  $G$ . Both moves leave some  $H_0$  where Left has a winning strategy playing second since the move in the first game was winning. In the second case, she can assume he chose any arc of  $S$  and continue to follow her strategy. For similar reasons, it is possible and it is winning.

The proof that Right wins  $G' + H$  whenever he wins  $G + H$  is similar.  $\square$

Using this reduction, the number of cycles decreases strictly, so after repeating the process as many times as possible (which is a finite number of times), we end up with a directed graph with no cycle, namely an orientation of a forest.

**Corollary 2.15** *For any directed graph  $G$ , there exists an orientation of a forest  $F_G$  such that  $G =^+ F_G$  and such an  $F_G$  is computable in quadratic time.*

In Corollary 2.15, the complexity is important, as it is easy to produce an orientation of a forest (even an orientation of a path) with any Grundy-value:

define  $P_n$  the oriented graph with vertex set

$$V(P_n) = \{v_i\}_{0 \leq i \leq n}$$

and arc set

$$A(P_n) = \{(v_{i-1}, v_i)\}_{1 \leq i \leq n}.$$

Then the TIMBER position  $P_n$  has Grundy-value  $n$ .

**Example 2.16** Figure 2.12 shows an example of a directed graph (on top) and a corresponding forest (on bottom), obtained after applying the reduction from Theorem 2.14. The cycles are coloured grey and reduced to the grey vertices of the forest. The white vertices denote the vertices of degree 1 we add with an out-arc toward those grey vertices. There might be several such forests depending on the choice of the component used for the reduction, but they all share the same Grundy-value. Choosing maximal 2-connected components when reducing leads to a unique forest with least number of vertices.

The next proposition allows us another reduction. In particular, it gives another proof that all forests that can be obtained from a graph  $G$  after the reduction of Theorem 2.14 are equivalent (set  $k$  and  $\ell$  to 0).

**Proposition 2.17** *Let  $T$  be an orientation of a tree such that there exist three sets of vertices  $\{u_i\}_{0 \leq i \leq k}$ ,  $\{v_i\}_{0 \leq i \leq k}$ ,  $\{w_i\}_{0 \leq i \leq \ell} \subset V(G)$  such that:*

1.  $(\{(u_{i-1}, u_i)\}_{1 \leq i \leq k} \cup \{(v_{i-1}, v_i)\}_{1 \leq i \leq k} \cup \{(w_{i-1}, w_i)\}_{1 \leq i \leq \ell}) \subset A(G)$
2.  $(u_k, w_0), (v_k, w_\ell) \in A(G)$ .
3.  $u_0$  and  $v_0$  have in-degree 0 and out-degree 1.
4. for all  $1 \leq i \leq k$ ,  $u_k$  and  $v_k$  have in-degree 1 and out-degree 1.

Let  $T'$  be the orientation of a tree with vertex set

$$V(T') = V(T) \setminus \{v_i\}_{0 \leq i \leq k}$$

and arc set

$$A(T') = A(T) \setminus (\{(v_{i-1}, v_i)\}_{1 \leq i \leq k} \cup \{(v_k, w_\ell)\}).$$

Then  $T =^+ T'$ .

**Proof.** The proof is similar to the one of Theorem 2.14: playing on  $(v_{i-1}, v_i)$  or  $(u_{i-1}, u_i)$  is similar (as well as  $(v_k, w_\ell)$  and  $(u_k, w_0)$ ), and no move apart from some  $(v_{j-1}, v_j)$  (and  $(v_k, w_\ell)$ ) would remove the arc  $(u_{i-1}, u_i)$  without removing the arc  $(v_{i-1}, v_i)$ . □

Note that we never used the fact we were considering the normal version of the game when we proved both the reductions from Theorem 2.14 and Proposition 2.17. That means they can be used in the misère version as well.

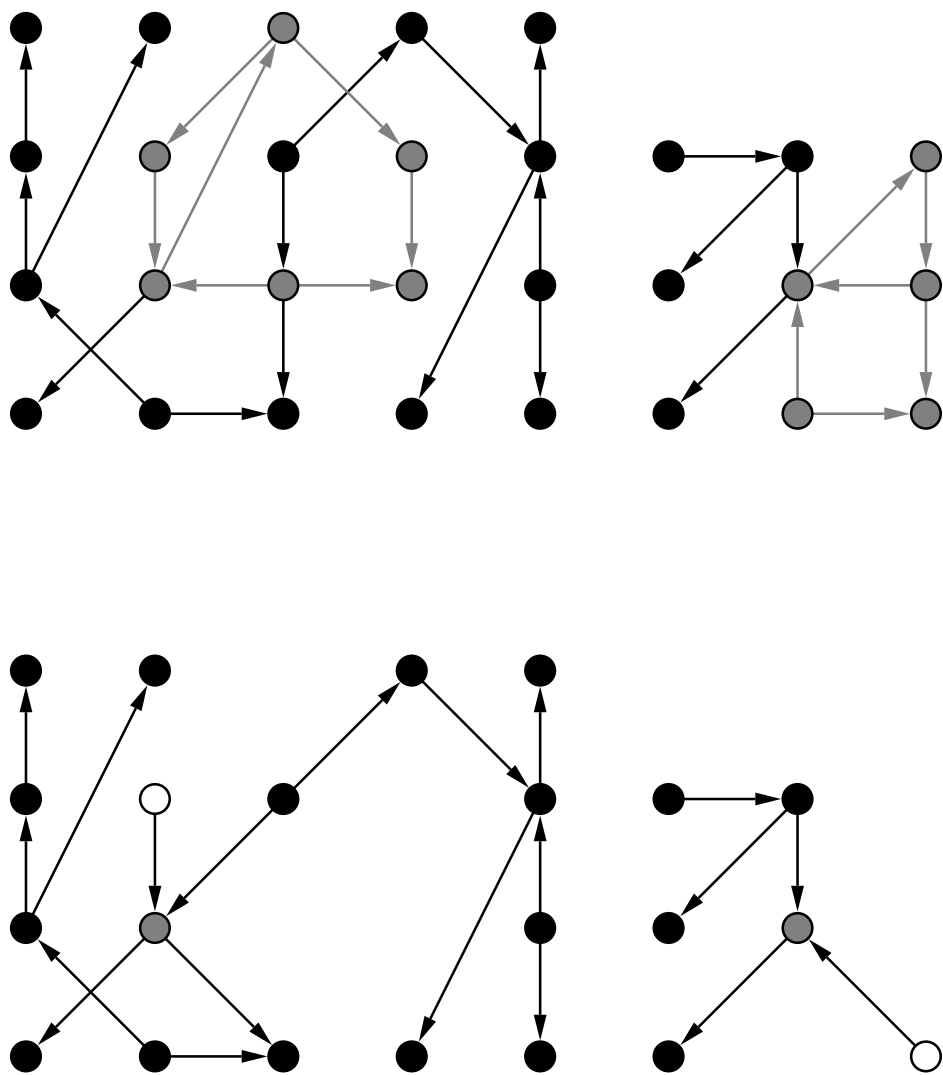


Figure 2.12: A TIMBER position and a corresponding orientation of a forest



**Figure 2.13:** A TIMBER position and its image after reduction having different Grundy-values

### 2.2.2 Trees

Knowing we can consider only forests without loss of generality, we now focus on trees. Though we are not able to give the Grundy-value of any tree, which would have the problem completely solved (being able to find the outcome of any forest is actually equivalent to being able to find the Grundy-value of any tree), we find their outcomes using two more reductions, one of them leaving the Grundy-value unchanged.

First, we note that if we can finish the game in one move, that is we can remove all the arcs of the graph, the game is an  $\mathcal{N}$ -position.

**Lemma 2.18** *Let  $T$  be an orientation of a tree such that there is a leaf  $v$  of  $T$  with out-degree 1. Then  $o^+(T) = \mathcal{N}$ , that is  $T$  is a next-player win position.*

**Proof.** Let  $x$  be the out-neighbour of  $v$ . The first player wins by toppling the domino on the arc  $(v, x)$ .  $\square$

The next lemma eliminates couples of moves that keep being losing moves throughout the whole game as long as they are both available. Unfortunately, though this reduction keeps the outcome of the position, it may change its Grundy-value, and we know some cases where the Grundy-value is changed, as well as some others where it is not:

- Figure 2.13 shows an example of a position which changes Grundy-value after applying the reduction. On the left, the graph has Grundy-value 3, and on the right, the reduced graph has Grundy-value 1.
- All  $\mathcal{P}$ -positions have same Grundy-value (namely 0), so any  $\mathcal{P}$ -position that reduces keeps the Grundy-value unchanged. And Figure 2.14 shows an example of an  $\mathcal{N}$ -position which keeps the Grundy-value unchanged after applying the reduction: both positions have Grundy-value 2.

**Lemma 2.19** *Let  $T_1, T_2$  be two TIMBER positions. Choose  $y \in V(T_1)$ ,  $z \in V(T_2)$  and let  $x$  be a vertex disjoint from  $T_1$  and  $T_2$ . Let  $T$  be the position with vertex set*

$$V(T) = V(T_1) \cup \{x\} \cup V(T_2)$$

*and arc set*

$$A(T) = A(T_1) \cup \{(x, y), (x, z)\} \cup A(T_2).$$





**Figure 2.14:** A TIMBER  $\mathcal{N}$ -position and its image after reduction having the same Grundy-value

Let  $T'$  be the position with vertex set

$$V(T') = V(T_1) \cup V(T_2)$$

where  $y$  and  $z$  are identified, and arc set

$$A(T') = A(T_1) \cup A(T_2).$$

Then  $o^+(T) = o^+(T')$ .

**Proof.** We show it by induction on the number of vertices of  $T'$ . If  $V(T') = \{y\}$ , then there is no move in  $T'$  and  $T$  consists in two arcs going out the same vertex. Hence  $o^+(T) = \mathcal{P} = o^+(T')$ . Assume now  $|V(T')| > 1$ . Assume the first player has a winning move in  $T$ . If the chosen arc removes  $x$  from the game, choosing the same arc in  $T'$  leaves the same position. Otherwise, choosing the same arc in  $T'$  leaves a position which has the same outcome by induction. Hence the first player has a winning move in  $T'$ . The proof that she has a winning move in  $T$  if she has one in  $T'$  is similar.  $\square$

**Example 2.20** The reduction is from  $T$  to  $T'$ . Figures 2.15 and 2.16 illustrate the reduction by giving an example of an orientation of a tree and its image after reduction. The initial graph has no move that empties it, so we try to find a smaller graph with the same outcome. The grey arcs are the ones we contract, and the reduction cannot be applied anywhere else on the first tree. However, the reduction can again be applied on the grey arcs of the second tree (and only them).

The next lemma presents a reduction which preserves the Grundy-value. When there are two orientations of paths directed toward a leaf from a common vertex  $x$ , none of these paths affect the other, or the rest of the tree. Hence we can replace them with just one path, whose length is the Nim-sum of the lengths of the original paths.

**Lemma 2.21** Let  $T_0$  be an orientation of a tree,  $w \in V(T_0)$  a vertex, and  $n, m \in \mathbb{N}$  two integers. Let  $T$  be the position with vertex set

$$V(T) = V(T_0) \cup \{y_i\}_{1 \leq i \leq n} \cup \{z_i\}_{1 \leq i \leq m}$$

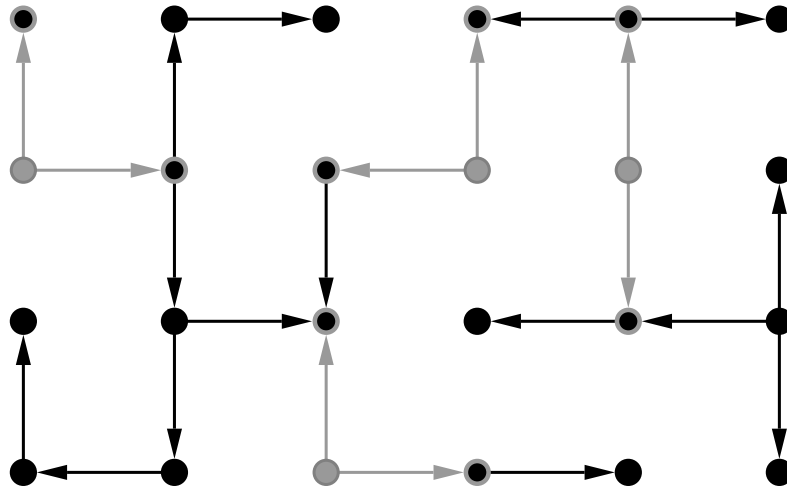


Figure 2.15: An orientation of a tree seen as a TIMBER position

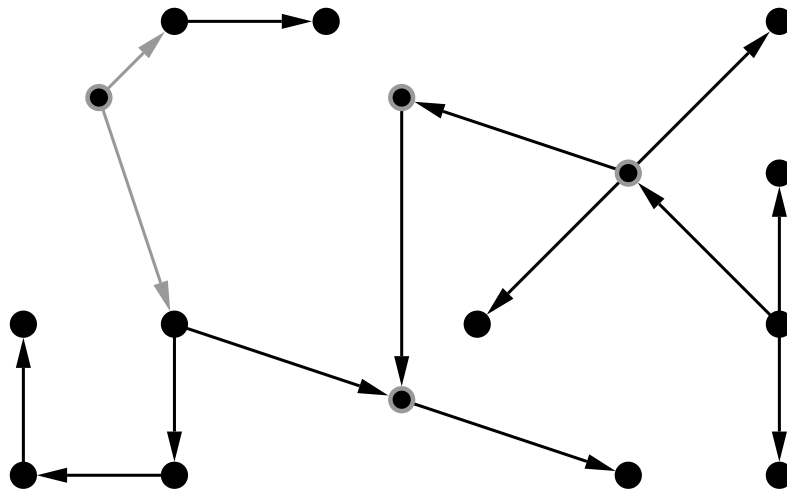


Figure 2.16: Its image after reduction, having the same outcome

and arc set

$$A(T) = A(T_0) \cup \{(y_i, y_{i+1})\}_{1 \leq i \leq n-1} \\ \cup \{(z_i, z_{i+1})\}_{1 \leq i \leq m-1} \\ \cup \{(w, y_1), (w, z_1)\}.$$

Let  $T'$  be the position with vertex set

$$V(T') = V(T_0) \cup \{x_i\}_{1 \leq i \leq n \oplus m}$$

and arc set

$$A(T') = A(T_0) \cup \{(x_i, x_{i+1})\}_{1 \leq i \leq (n \oplus m) - 1} \cup \{(w, x_1)\}.$$

Then  $o^+(T + T') = \mathcal{P}$  and  $o^+(T) = o^+(T')$ .

**Proof.** We prove it by induction on  $|V(T_0)| + n + m$  and show that  $o^+(T + T') = \mathcal{P}$  which means  $g(T) = g(T')$  and thus implies that  $o^+(T) = o^+(T')$ . If  $n + m = 0$ ,  $T = T_0 = T'$ .

Assume now  $|V(T_0)| + n + m > 0$ . Any arc of  $T_0$  is in both  $T$  and  $T'$ , thus if the first player chooses such an edge in one of  $T$  or  $T'$  then the second player can choose the corresponding arc in  $T'$  or  $T$ , which leaves a  $\mathcal{P}$ -position (either by induction or because the two remaining positions are the same). Assume the first player chooses the arc  $(y_i, y_{i+1})$  (or  $(w, y_1) = (y_0, y_1)$ ). If  $(i \oplus m) < (n \oplus m)$ , the second player can choose the arc  $(x_{i \oplus m}, x_{(i \oplus m) + 1})$  (or  $(w, x_1)$  if  $i \oplus m = 0$ ) which leaves a  $\mathcal{P}$ -position by induction. Otherwise, there exists  $j < m$  such that  $(i \oplus j = n \oplus m)$ , and the second player can choose the arc  $(z_j, z_{j+1})$  which leaves a  $\mathcal{P}$ -position by induction. Similarly, we can prove that the second player has a winning answer to any move of the type  $(x_i, x_{i+1})$  or  $(z_i, z_{i+1})$ .  $\square$

**Example 2.22** Again, the reduction is from  $T$  to  $T'$ . Figures 2.17 and 2.18 illustrate the reduction by giving an example of an orientation of a tree and its image after reduction. The initial graph has no move that empties it, and the reduction from Lemma 2.19 cannot be applied, so we use the other reduction to get a smaller tree having the same outcome (even better, having the same Grundy-value). The grey arcs of the first tree are the ones of the paths we merge, and the reduction cannot be applied anywhere else on the first tree. The grey arcs of the second tree are the ones of the paths we created by merging those of the first tree. The reduction can again be applied on the second tree, where it is even possible to apply the reduction from Lemma 2.19.

A position for which we cannot apply the reduction from Lemma 2.19 or Lemma 2.21 is called *minimal*. A *leaf path* is a path from a vertex  $x$  to a leaf  $y$ , with  $x \neq y$ , consisting only of vertices of degree 2, apart from  $y$  and possibly  $x$ .

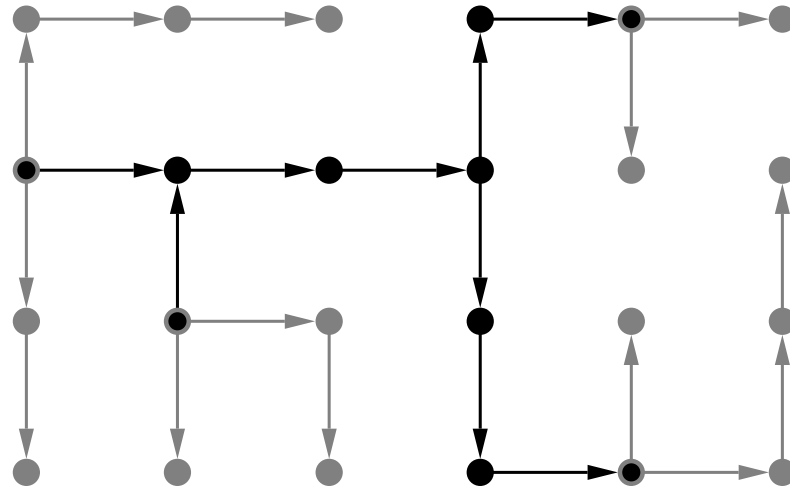


Figure 2.17: An orientation of a tree seen as a TIMBER position

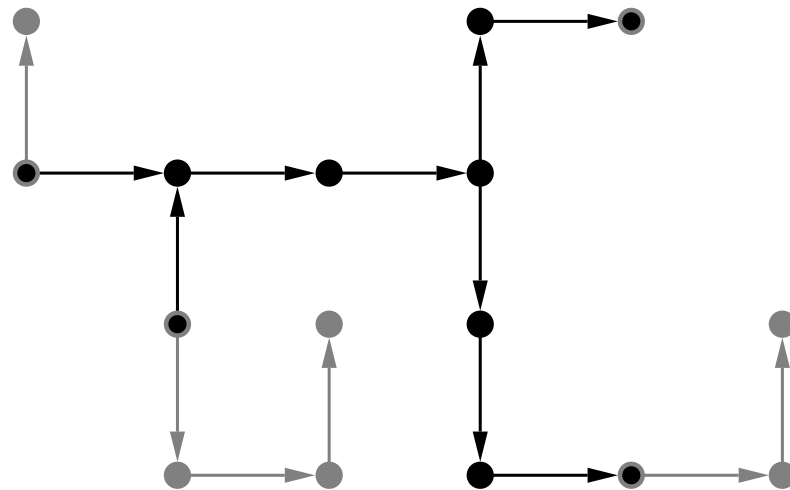


Figure 2.18: Its image after reduction, having the same outcome

The coming lemma is important because it gives us the outcome of a minimal position. Thus after having reduced our initial position as much as we could, we get its outcome. Furthermore, if it is an  $\mathcal{N}$ -position, it proposes a winning move, that we can backtrack to get a winning move from the initial position.

**Lemma 2.23** *A minimal position with outcome  $\mathcal{P}$  can only be a graph with no arc.*

**Proof.** Let  $T$  be a minimal position with at least one arc. If it has exactly one arc, it is obviously in  $\mathcal{N}$ , so we can assume  $T$  has at least two arcs. Then there exists a vertex  $w$  at which there are two leaf paths  $\{x_i\}_{0 \leq i \leq n}$  and  $\{y_i\}_{0 \leq i \leq m}$  ( $x_0 = w = y_0$ ). If  $(x_n, x_{n-1})$  or  $(y_m, y_{m-1})$  is an arc, the first player can choose it and win. Now assume both  $(x_{n-1}, x_n)$  and  $(y_{m-1}, y_m)$  are arcs. As  $T$  is minimal, it cannot be reduced using Lemma 2.19, so all  $(x_i, x_{i+1})$ ,  $(y_i, y_{i+1})$ ,  $(w, x_1)$  and  $(w, y_1)$  are arcs. But then we can apply the reduction from Lemma 2.21, which is a contradiction.  $\square$

Applying reductions from Lemma 2.19 and Lemma 2.21 leads us to a position where finding the outcome is easy: either the graph has no arc left and it is a  $\mathcal{P}$ -position or there is a move that empties the graph and it is an  $\mathcal{N}$ -position. Note that the reduction from Lemma 2.19 decreases the number of vertices without increasing the number of leaves, and the reduction from Lemma 2.21 decreases the number of leaves without increasing the number of vertices, so they can only be applied a linear number of times. As finding where to apply the reduction can be done in linear time, this leads to a quadratic time algorithm.

**Theorem 2.24** *We can compute the outcome of any connected oriented graph  $G$  in time  $O(|V(G)|^2)$ .*

Note that for a tree, the number of edges is equal to the number of vertices minus one, and a connected graph containing a cycle is always an  $\mathcal{N}$ -position. Hence, we can consider  $O(|V(G)|) = O(|E(G)|)$  for the reduction part of the algorithm since finding a cycle is linear in the number of vertices.

Though this is enough to compute the outcome of any orientation of trees, it does not give us its Grundy-value, except when we are considering a  $\mathcal{P}$ -position as they all have Grundy-value 0. The first reduction we presented in this subsection may change the Grundy-value of the position, but it is not the case of the second reduction. Looking further on that direction, we tried to find a more general reduction that takes two leaf paths out of the same vertex and replace them with only one leaf path out of that vertex, leaving the rest of the graph unmodified, and keeping the Grundy-value unchanged.

With this, we would reduce the tree to a path, and as we can compute the Grundy-value of a path relatively efficiently (see Theorem 2.26 below), we would get an algorithm to compute the Grundy-value of any orientation of trees, leading to an algorithm to compute the outcome (and even the Grundy-value) of any orientation of forests, and thus of any directed graph. Unfortunately, doing this on general leaf paths is not possible, as shown in Example 2.25.

**Example 2.25** Define  $P_1$  and  $P_2$  two orientations of paths with vertex set

$$V(P_i) = \{x_i, y_i, z_i\}$$

and arc set

$$A(P_i) = \{(x_i, y_i), (z_i, y_i)\}$$

for both  $i \in \{1, 2\}$ . Consider that the vertices identified with a vertex of the rest of the tree are  $x_1$  and  $x_2$ . Assume there is an orientation of a path  $P_3$  satisfying the above conditions. Identifying  $x_1$  and  $x_2$  without adding anything leaves a path with Grundy-value 2, so  $P_3$  should have Grundy-value 2. The moves that would remove the rest of the tree should each leave the same value as one of the moves that would remove the rest of the tree in our choice of  $P_1$  and  $P_2$ , because we cannot ensure that these values would appear in the rest of the tree, so they all should have Grundy-value 0, and there should be at least one for each value left by a move that would remove the rest of the tree in our choice of  $P_1$  and  $P_2$  for the same reasons, so there should be at least one move in  $P_3$  that would remove the rest of the tree and leave a position with Grundy-value 0. Among all those potential arcs, we look at the one closest to the leaf of that leaf path, and call it  $a$ . If there are any arcs closer to the leaf, they are all pointing towards the leaf, and the Grundy-value of those arcs, that are left alone after a player would have moved on  $a$ , is equal to the number of arcs. Hence there are no closer arc. There cannot be any other arc in  $P_3$  that would remove the rest of the tree, because it would leave the arc  $a$  that still could empty the graph, which means it would leave a position with Grundy-value different from 0. As the Grundy-value of  $P_3$  should be 2, the only possible  $P_3$  with the above conditions is the graph with vertex set

$$V(P_3) = \{x_3, y_3, z_3, t_3\}$$

and arc set

$$A(P_3) = \{(x_3, y_3), (y_3, z_3), (t_3, z_3)\},$$

with the vertex we identify with a vertex of the rest of the tree being  $x_3$ .

Unfortunately, if the rest of the tree is an isolated arc in which we identify the endpoint to a vertex of  $P_1$ ,  $P_2$  or  $P_3$ , the two graphs do not have the same Grundy-value: the one with  $P_1$  and  $P_2$  has Grundy-value 1 while the one with  $P_3$  has Grundy-value 3.

### 2.2.2.1 Paths

In the case of paths, we can show additional results compared to trees. The same algorithm may be used, and we can even spare the reduction of Lemma 2.21.

Using CGSuite [37], we determined the number of  $\mathcal{P}$ -positions on paths of length  $2n$  for small  $n$ 's. Imputing them in the On-line Encyclopedia of Integer Sequences [40] suggested that it corresponds to the  $n^{\text{th}}$  Catalan number, and pointed at a reference [12], which led to the following representation. A position can be represented visually on a 2-dimensional graph on a lattice: watch the path horizontally from left to right, start at  $(0, 0)$  and let an arc directed leftward be a line joining the lattice points  $(x, y)$  and  $(x + 1, y + 1)$  and an arc directed rightward be the line joining  $(x, y)$  and  $(x + 1, y - 1)$ .

We call that representation the *peak representation* of a TIMBER position on an orientation of a path.

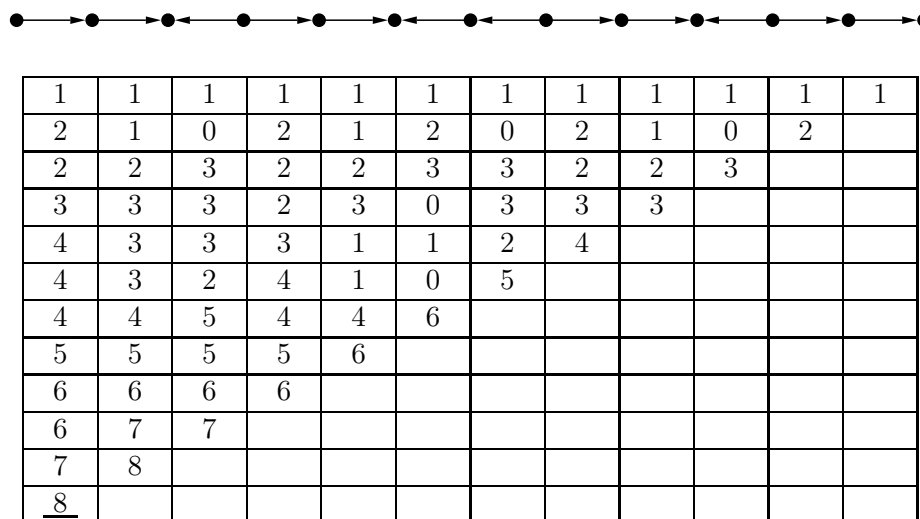
A *Dyck path of length  $2n$*  is one of these paths that also ends at  $(2n, 0)$  and which never goes below the  $x$ -axis. More formally, a Dyck path of length  $2n$  is a path on a lattice starting from  $(0, 0)$  and ending at  $(2n, 0)$  which steps are of the form  $((x, y), (x + 1, y + 1))$  and  $((x, y), (x + 1, y - 1))$  where the second coordinate is never negative.

We note that an orientation of a path is a  $\mathcal{P}$ -position if and only if its peak representation is a Dyck path. This gives us the number of  $\mathcal{P}$ -positions that are paths of length  $2k$ , the  $k^{\text{th}}$  Catalan number  $c_k = \frac{(2k)!}{k!(k+1)!}$ . And no path of odd length is a  $\mathcal{P}$ -position.

This is interesting since there are few games where the number of  $\mathcal{P}$ -positions is known depending on the size of the data. Even for NIM which was introduced a century ago, no general formula is known yet.

We now look at the Grundy-values of paths. All followers of a position of a TIMBER position are TIMBER positions whose graphs are induced subgraphs of the original one, where two vertices are in the same connected component if and only if they were in the same connected component in the original graph. When the graph is a path, the number of connected induced subgraphs is quadratic in the length of the path ( $E(G) - i + 1$  choices of subgraphs with  $i$  edges, for any  $i$ ). When you know the Grundy-values of all the options of a game, the Grundy-value of this game can be computed in linear time. The number of options of a TIMBER position is the number of its edges. It therefore suffices to compute and store the Grundy-values of all subpaths of an orientation of a path by length increasing order to get the Grundy-value of the original path in cubic time.

**Theorem 2.26** *We can compute the Grundy-value of any orientation of paths  $P$  in time  $O(|V(P)|^3)$ .*



**Figure 2.19:** Computing the Grundy-value of a path

**Example 2.27** Figure 2.19 gives an example of a path and the Grundy-value of all its subpaths, illustrating the algorithm: on the  $i^{\text{th}}$  line are the Grundy-values of subpaths of length  $i$ ; on the  $j^{\text{th}}$  column are the Grundy-values of the subpaths whose leftmost arc is the  $j^{\text{th}}$  of the original path. We can consider there is a  $0^{\text{th}}$  line which only contains 0's, but this is not necessary as the first line always only contains 1's. We underlined the Grundy-value of the whole path.

To compute the value in case  $(i, j)$ , that is the Grundy-value of the subpath containing the  $k^{\text{th}}$  arc for all  $k$  between  $i$  and  $i + j - 1$ , you look at each of these edges and build the set of Grundy-values of the options of the subpath: you start with an empty set of values; if the  $k^{\text{th}}$  arc is directed toward the right, you add the value in case  $(i, k - i)$  to your set; if the  $k^{\text{th}}$  arc is directed toward the left, you add the value in case  $(k + 1, i + j - k - 1)$  to your set. The value you put in case  $(i, j)$  is the minimum non-negative integer that does not appear in the set you just built.

---

## 2.3 Perspectives

---

In this chapter, we looked at the games VERTEXNIM and TIMBER.

In the case of VERTEXNIM, we gave a polynomial-time algorithm to find the normal outcome of any undirected graph with a token on any vertex, as well as the outcome of any strongly connected directed graph with a self loop on every vertex, and a token on any vertex. Then, we have a natural question.



**Question 2.28** *What is the complexity of VERTEXNIM played on a general directed graph?*

Looking at another variant of NIM played on graphs, VERTEX NIMG [9, 43], our results seem to apply to the variant where a vertex of weight 0 is not removed (see [16]), but they do not if it is removed. In particular, in the latter case, the problem is PSPACE-complete on graphs with a self loop on each vertex, even if the weight of vertices is at most 2.

In the case of TIMBER, we found the normal outcome of any orientation of trees, which gives the normal outcome of any connected directed graph in polynomial time, and gave an algorithm to find the Grundy-value of any orientation of paths in polynomial time.

We are now left with the following problem.

**Question 2.29** *Is there a polynomial-time algorithm to find the Grundy-value of any TIMBER position on orientations of trees?*

Note that it would give the outcome of any TIMBER position on directed graphs, as a directed graph reduces to an orientation of a forest having the same Grundy-value by Theorem 2.14, and from that forest, we would be able to compute the Grundy-value of each connected components as they are all trees and we just need to sum the values to find the Grundy-value of the original position, which also gives its outcome.

The complexity of the problem is the same as finding the outcome of any TIMBER position on directed graphs, as a position has Grundy-value  $n$  if and only if the second player wins the game made of the sum of that position with the orientation of a path with  $n$  arcs, all directed toward the same leaf, and the Grundy-value of a TIMBER position is bounded by its number of arcs.



## Chapter 3

## Partizan games

**P**artizan games are the natural extension of impartial games where the players may have different sets of moves. We say that a game is partizan whenever the moves are not necessarily equal for the two players, but partizan games contain impartial games as well.

As with impartial games, there exists a function that assigns a value to any partizan game. Two games having the same value are equivalent under normal play, and vice versa. Hence, we identify those values with the canonical forms of the games they represent. As an example, the canonical forms of numbers are recursively defined as follows (with  $n, k$  being positive integers and  $m$  any integer):

$$\begin{aligned} 0 &= \{\cdot|\cdot\} \\ n &= \{n-1|\cdot\} \\ -n &= \{\cdot|-n+1\} \\ \frac{2m+1}{2^k} &= \left\{ \frac{2m}{2^k} \mid \frac{2m+2}{2^k} \right\} \end{aligned}$$

The order between games represented by numbers is the same as in  $\mathbb{Q}_2$ . Unfortunately, many values are not numbers. For example, an impartial game with Grundy-value  $n$  would be denoted as having value  $*n$ , except when  $n$  is 0 or 1, respectively denoted by 0 and  $*$ . Berlekamp, Conway and Guy [4, 10] give a useful tool to prove some games are numbers:

**Theorem 3.1 (Berlekamp et al. [4], Conway [10]) [Simplicity theorem]** *Suppose for  $x = \{x^L|x^R\}$  that some number  $z$  satisfies  $z \not\leq x^L$  and  $z \not\geq x^R$  for any Left option  $x^L \in x^L$  and any Right option  $x^R \in x^R$ , but that no (canonical) option of  $z$  satisfies the same condition (that is, for any option  $z' \in z^L \cup z^R$ , there exists a Left option  $x^L \in x^L$  such that  $z' \leq x^L$  or there exists a Right option  $x^R \in x^R$  such that  $z' \geq x^R$ ). Then  $x = z$ .*

In other words, if there is a number  $z$  satisfying  $z \not\leq x^L$  and  $z \not\geq x^R$  for any Left option  $x^L \in x^L$  and any Right option  $x^R \in x^R$ , then  $x$  is equivalent to the number with smallest birthday satisfying this property.

To simplify proofs, we often do not state results on the opposite of games on which we proved similar results. This can be justified by the following proposition.

**Proposition 3.2** *Let  $G$  and  $H$  be any two games. If  $G \geq^+ H$ , then  $-G \leq^+ -H$ . As a consequence,  $G \equiv^+ H \Leftrightarrow -G \equiv^+ -H$ .*

**Proof.** Assume  $G \geq^+ H$ . Then Left wins  $G - H = (-H) - (-G)$  playing second. Hence  $-H \geq^+ -G$ .  $\square$

In this chapter, we consider three partizan games: TIMBUSH, TOPPLING DOMINOES and COL. TIMBUSH is the natural partizan extension of TIMBER, where some arcs can only be chosen by one player. In section 3.1, we define the game, prove that any position can be reduced to a forest, as in TIMBER, and give an algorithm to compute the outcome of any orientation of paths and any orientation of trees where no arc can be removed by both players. TOPPLING DOMINOES is a variant of TIMBUSH, where the graph is a forest of paths and all arcs are bidirectional. In section 3.2, we define the game, prove the existence of some values appearing as connected paths, and give a unicity result about some of them. COL is a colouring game played on an undirected graph. In section 3.3, we define the game and give the values of graphs belonging to some infinite classes of graphs.

The results presented in Section 3.1 are a joint work with Richard Nowakowski, while the results presented in Sections 3.2 and 3.3 are a joint work with Paul Dorbec and Éric Sopena [14].

---

<b>3.1</b>	<b>TIMBUSH</b>	<b>44</b>
3.1.1	General results	45
3.1.2	Paths	49
3.1.3	Black and white trees	54
<b>3.2</b>	<b>TOPPLING DOMINOES</b>	<b>61</b>
3.2.1	Preliminary results	63
3.2.2	Proof of Theorem 3.27	65
<b>3.3</b>	<b>COL</b>	<b>72</b>
3.3.1	General results	76
3.3.2	Known results	80
3.3.3	Caterpillars	93
3.3.4	Cographs	96
<b>3.4</b>	<b>Perspectives</b>	<b>98</b>

---

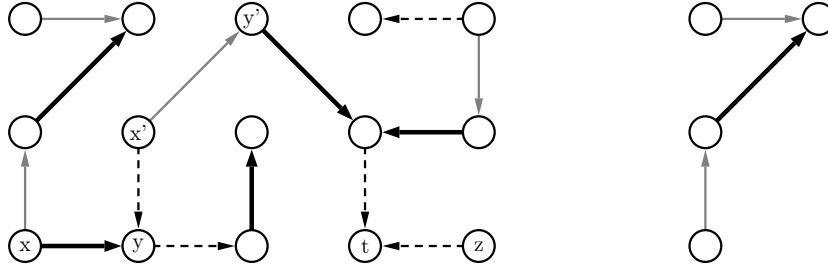


---

## 3.1 TIMBUSH

---

TIMBUSH is the natural partizan extension of TIMBER, played on a directed graph with arcs coloured black, white, or grey. On her move, Left chooses



**Figure 3.1:** Playing a move in TIMBUSH

a black or grey arc  $(x, y)$  of the graph and removes it along with all that is still connected to the endpoint  $y$  in the underlying undirected graph. On his move, Right does the same with a white or grey arc.

The description of a position consists of the directed graph on which the two players are playing, and a colouring function from the set of arcs to the set of colours  $\{\text{black, white, grey}\}$ . Note that the directed graph does not need to be strongly connected, or even connected.

All TIMBER positions are TIMBUSH positions: just keep the same directed graph and consider all arcs are grey.

In all the figures, white arcs are represented with dashed arrows, and black arcs are thicker, to avoid confusion between the colours.

**Example 3.3** Figure 3.1 gives an example of a Left move. Left chooses to remove the black arc  $(x, y)$ . The whole connected component containing  $y$  in the underlying undirected graph without the arc  $(x, y)$  is removed with it. She could not have chosen the arc  $(z, t)$  because it is white, but the grey arc  $(x', y')$  is allowed to her.

In this section, we present algorithms to find the normal outcome of any coloured orientation of a path, and the normal outcome of any coloured connected directed graph with no grey arc.

### 3.1.1 General results

First, we see how to adapt the results obtained on TIMBER to TIMBUSH. The reduction to get an orientation of a forest from a directed graph without changing the value is the same, but we now have to take care of the colours of the arcs too. We aim at keeping them the same, but we still need to find the colour of the arc we add, and we choose the colour that gives the same possibilities as those given by the cycle. The proof follows the same pattern as the proof of Theorem 2.14.

**Theorem 3.4** *Let  $G$  be a directed graph seen as a TIMBUSH position such that there exist a set of vertices  $S$  that forms a 2-edge-connected component of  $G$ , and  $x, y$  two vertices not belonging to  $S$ . Let  $G'$  be the directed graph with vertex set*

$$V(G') = (V(G) \setminus S) \cup \{x, y\}$$

*and arc set*

$$\begin{aligned} A(G') = & (A(G) \setminus \{(u, v) \mid \{u, v\} \cap S \neq \emptyset\}) \\ & \cup \{(u, x) \mid u \in (V(G) \setminus S), \exists v \in S, (u, v) \in A(G)\} \\ & \cup \{(x, u) \mid u \in (V(G) \setminus S), \exists v \in S, (v, u) \in A(G)\} \\ & \cup \{(y, x)\}. \end{aligned}$$

*keeping the same colours, where the colour of  $(y, x)$  is grey if the arcs in  $S$  yield different colours, and of the unique colour of arcs in  $S$  otherwise. Then  $G \equiv^+ G'$ .*

**Proof.** Let  $H$  be any game such that Left has a winning strategy on  $G + H$  playing first (or second). On  $G' + H$ , she can follow the same strategy unless it recommends to choose an arc between elements of  $S$  or Right chooses the arc  $(y, x)$ . In the first case, she can choose the arc  $(y, x)$ , which is still in play since any move removing  $(y, x)$  in  $G'$  would remove all arcs of  $S$  in  $G$ . Both moves leave some  $H_0$  where Left has a winning strategy playing second since the move in the first game was winning. In the second case, she can assume he chose any arc of  $S$  and continue to follow her strategy. For similar reasons, it is possible and it is winning.

The proof that Right wins  $G' + H$  whenever he wins  $G + H$  is similar.  $\square$

Again, we get the corollary that leaves us with a forest.

**Corollary 3.5** *For any directed graph  $G$ , there exists an orientation of a forest  $F_G$  such that  $G \equiv^+ F_G$  and  $F_G$  is computable in quadratic time.*

**Example 3.6** Figure 3.2 shows an example of a directed graph (on top) and a corresponding forest (on bottom), obtained after applying the reduction from Theorem 3.4. Light grey areas surround the cycles, which are reduced to the grey vertices of the forest. The white vertices denote the vertices of degree 1 we add with an out-arc toward those grey vertices. There might be several such forests depending on the choice of the component used for the reduction, but they all share the same value. Choosing maximal 2-connected components when reducing leads to a unique forest with least number of vertices.

We can also adapt the proposition giving us a reduction removing leaf-paths with arcs directed from the leaf, but we also need to pay attention to the colours, which gives extra conditions.

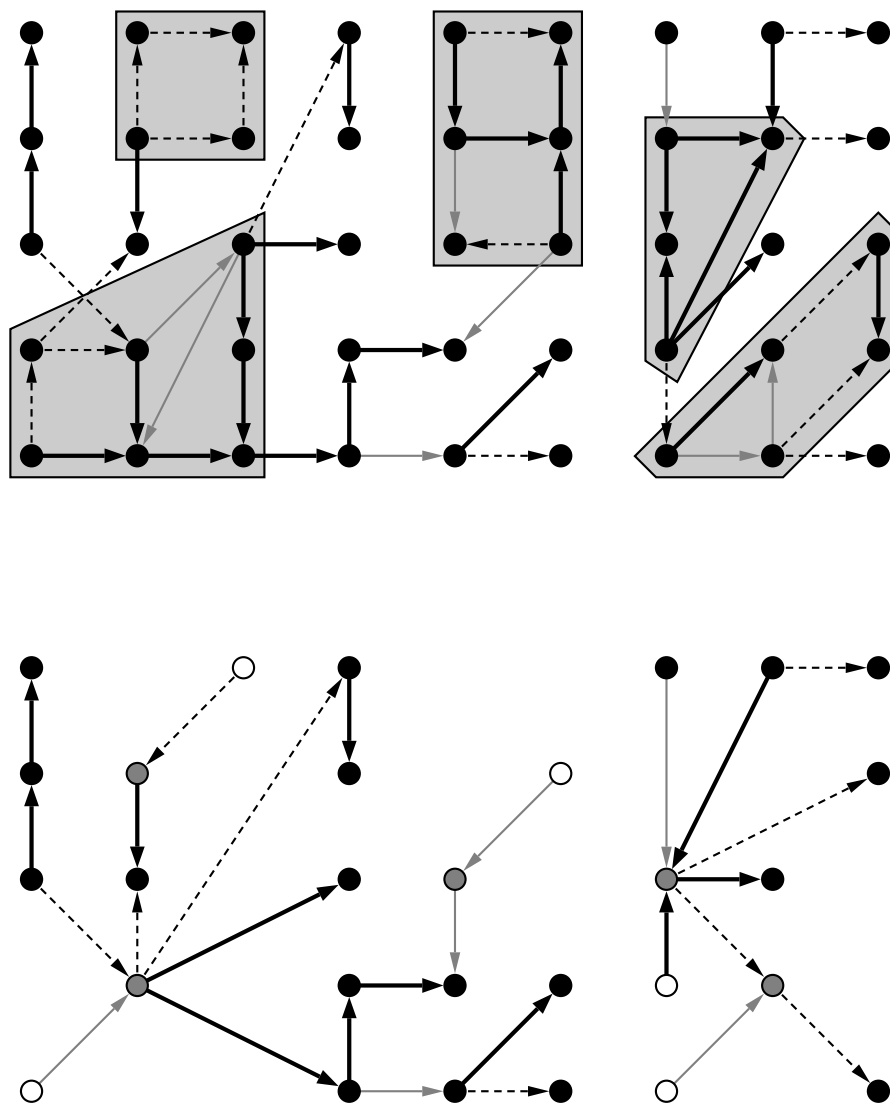


Figure 3.2: A TIMBUSH position and a corresponding orientation of a forest

**Proposition 3.7** *Let  $T$  be an orientation of a tree such that there exist three sets of vertices  $\{u_i\}_{0 \leq i \leq k}, \{v_i\}_{0 \leq i \leq k}, \{w_i\}_{0 \leq i \leq \ell} \subset V(G)$  such that:*

1.  $(\{(u_{i-1}, u_i)\}_{1 \leq i \leq k} \cup \{(v_{i-1}, v_i)\}_{1 \leq i \leq k} \cup \{(w_{i-1}, w_i)\}_{1 \leq i \leq \ell}) \subset A(G)$ .
2.  $\{(u_k, w_0), (v_k, w_\ell)\} \subset A(G)$ .
3.  $u_0$  and  $v_0$  have in-degree 0 and out-degree 1.
4. for all  $1 \leq i \leq k$ ,  $u_i$  and  $v_i$  have in-degree 1 and out-degree 1.
5. for all  $1 \leq i \leq k$ ,  $(u_{i-1}, u_i)$  and  $(v_{i-1}, v_i)$  have the same colour.
6.  $(u_k, w_0)$  and  $(v_k, w_\ell)$  have the same colour.

Let  $T'$  be the orientation of a tree with vertex set

$$V(T') = V(T) \setminus \{v_i\}_{0 \leq i \leq k}$$

and arc set

$$A(T') = A(T) \setminus (\{(v_{i-1}, v_i)\}_{1 \leq i \leq k} \cup \{(v_k, w_\ell)\})$$

keeping the same colours. Then  $T \equiv^+ T'$ .

**Proof.** The proof is similar to the one of Theorem 3.4, playing on  $(v_{i-1}, v_i)$  or  $(u_{i-1}, u_i)$  is similar (as well as  $(v_k, w_\ell)$  and  $(u_k, w_1)$ ), and no move apart from some  $(v_{j-1}, v_j)$  (and  $(v_k, w_\ell)$ ) would remove the arc  $(u_{i-1}, u_i)$  without removing the arc  $(v_{i-1}, v_i)$ .  $\square$

We now focus on trees again. Before going to specific cases, we give the analog of Lemma 2.19 in the partizan version. Note again that it sometimes changes the value of the game, and it sometimes does not, using the same examples as in Figures 2.13 and 2.14 as all positions of TIMBER are positions of TIMBUSH.

**Lemma 3.8** *Let  $T_1, T_2$  be two TIMBUSH positions. Choose  $y \in V(T_1)$ ,  $z \in V(T_2)$  and let  $x$  be a vertex not belonging to  $V(T_1)$  or  $V(T_2)$ . Let  $T$  be the position with vertex set*

$$V(T) = V(T_1) \cup \{x\} \cup V(T_2)$$

and arc set

$$E(T) = E(T_1) \cup \{(x, y), (x, z)\} \cup E(T_2)$$

where  $(x, y)$  and  $(x, z)$  are either both grey or of non-grey different colours and the other arcs keep the same colours. Let  $T'$  be the position with vertex set

$$V(T') = V(T_1) \cup V(T_2)$$



where  $y$  and  $z$  are identified, and arc set

$$E(T') = E(T_1) \cup E(T_2)$$

keeping the same colours for all arcs. Then  $o^+(T) = o^+(T')$ .

**Proof.** We show it by induction on the number of vertices of  $T'$ . If  $V(T') = \{y\}$ , then there is no move in  $T'$  and  $T$  is either  $1 + (-1) = 0$  or  $* + * = 0$ . Hence  $o^+(T) = \mathcal{P} = o^+(T')$ . Assume now  $|V(T')| > 1$ . Assume Left has a winning move in  $T$ . This winning move cannot be by choosing  $(x, y)$  or  $(x, z)$  because Right would choose the other move and win. If the chosen arc removes  $x$  from the game, choosing the same arc in  $T'$  leaves the same position. Otherwise, choosing the same arc in  $T'$  leaves a position which has the same outcome by induction. Hence Left has a winning move in  $T'$ . The proof that Left has a winning move in  $T$  if she has one in  $T'$  and that Right has a winning move in  $T$  if and only if he has one in  $T'$  are similar.  $\square$

**Example 3.9** Again, the reduction is from  $T$  to  $T'$ . Figures 3.3 and 3.4 illustrate the reduction by giving an example of an orientation of a tree and its image after reduction. Not even one player has a move that empties the initial graph, so we try to find a smaller graph with the same outcome. The arcs in light grey areas are the ones we contract, and the reduction cannot be applied anywhere else on the first tree. The dark grey area indicates a pair of arcs going out a degree-2 vertex, which cannot be contracted because its colours do not match the statement of Lemma 3.8. However, the reduction can again be applied on the arcs in the light grey areas of the second tree (and only on them).

### 3.1.2 Paths

Though finding an efficient algorithm which gives the normal outcome of any orientation of trees has eluded us, we can determine the normal outcome of any orientation of paths.

On paths, we can code the problem with a word. The letter  $K$  (resp.  $C$ ,  $Q$ ) would represent a black (resp. grey, white) arc directed leftward, while  $Y$  (resp.  $J$ ,  $D$ ) would represent a black (resp. grey, white) arc directed rightward. Let  $w = w_1w_2 \cdots w_{|w|}$ .

As in Section 2.2, we can see it as a row of dominoes, each coloured black, grey or white, that would topple everything in one direction when chosen, where chosen dominoes can only be toppled face up, with Left only being allowed to choose black or grey dominoes, and Right only being allowed to choose white or grey dominoes. The position is read from left to right.

**Example 3.10** Figure 3.5 shows an orientation of a path, the row of dominoes and the word used for coding it.

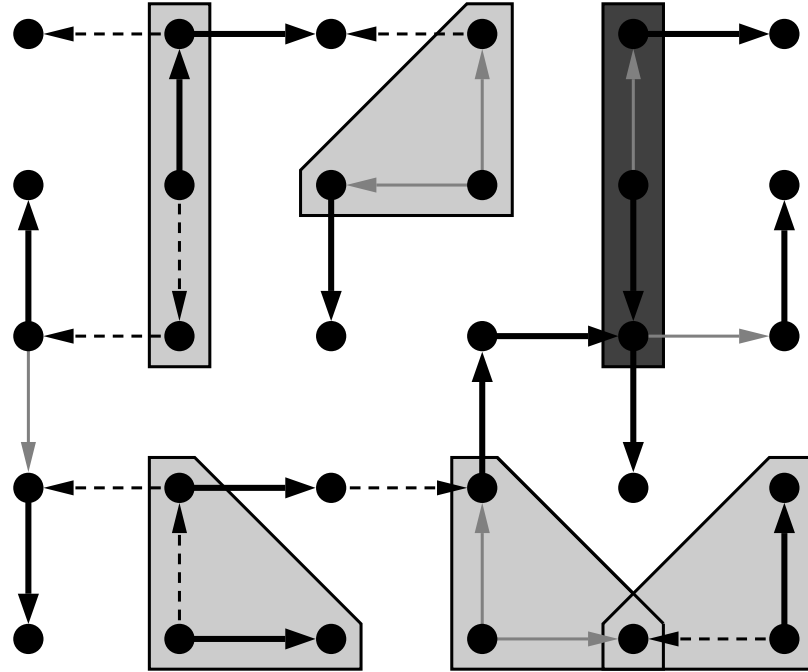


Figure 3.3: An orientation of a tree seen as a TIMBUSH position

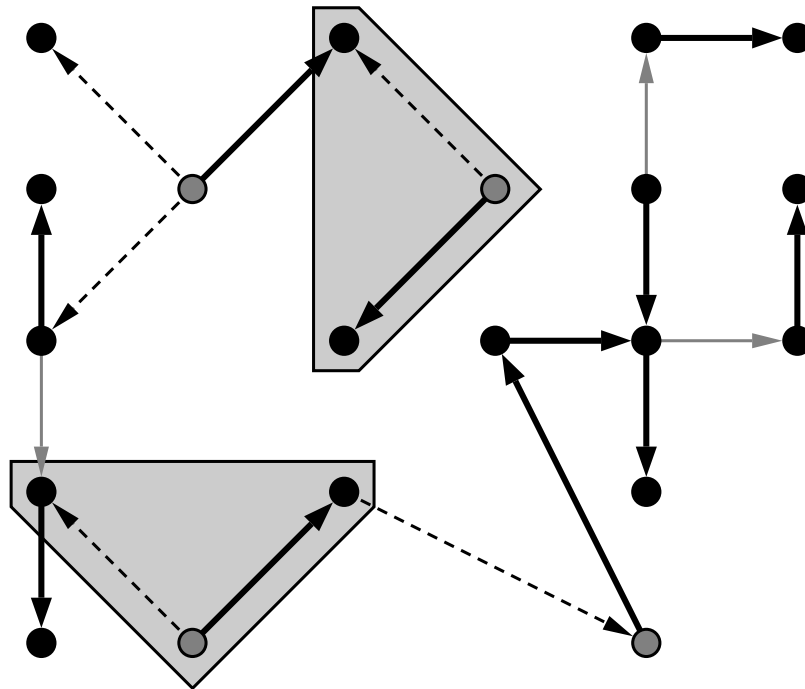
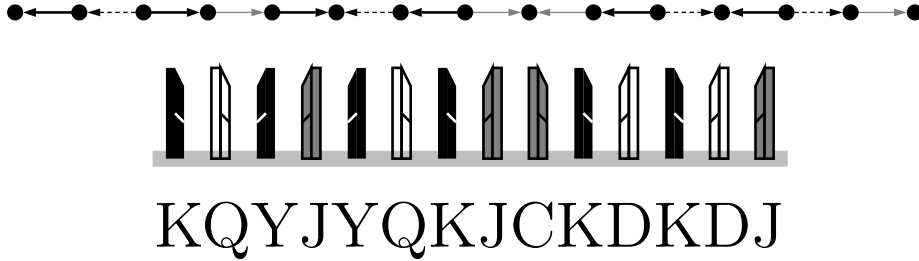


Figure 3.4: Its image after reduction, having the same outcome



**Figure 3.5:** A TIMBUSH position, the corresponding row of dominoes and the corresponding word

We say a domino is right-topplable if it corresponds to an arc directed rightward, that is if it is represented by a  $Y$ , a  $J$  or a  $D$ . Likewise, a domino represented by a  $K$ , a  $C$  or a  $Q$  is said to be left-topplable.

The next lemma is quite useful as it tells us that if we have a winning move for one player, then the only possible winning move going in the same direction for the other player is the exact same move, if available. This is natural as if they were different winning moves, one player would be able to play their move after the other player, and leave the same position as if they had played it first. Nevertheless, it is still possible for one player to have several winning moves going in the same direction when their opponent has no winning move going in that direction. And it is also possible that the two players have different winning moves, if they topple in different directions.

**Lemma 3.11** *If both players have a winning move toppling rightward, then these moves are on the same domino.*

**Proof.** Assume Left has a winning move toppling the right-topplable domino  $w_i$  and Right has a winning move toppling the right-topplable domino  $w_j$ . If  $i < j$ , after Right topples  $w_j$ , Left can topple  $w_i$ , leaving the game in the same position as if she had toppled  $w_i$  right in the beginning, which is a winning move, and toppling  $w_j$  was not winning for Right. The proof is similar if  $i > j$ .  $\square$

We define the following three sets of words:

$$\begin{aligned} L &= \{KY, KJ\} \cup \{CYD^nY, CYD^nJ\}_{n \in \mathbb{N}} \\ R &= \{QD, QJ\} \cup \{CDY^nD, CDY^nJ\}_{n \in \mathbb{N}} \\ E &= \{KD, CJ, QY\} \end{aligned}$$

The reader would have recognised  $E$  as the set of subwords that can be deleted without modifying the normal outcome of the path using Lemma 3.8. In the following, we then often assume the position does not contain any element of  $E$  as a subword.

The sets  $L$  and  $R$  would represent the sets of subwords that Left and Right would need to appear first to have a winning move on a right-topplable domino when the reduced word starts with a left-topplable domino, as we prove in Lemma 3.13.

The next lemma gives information on subwords of a word representing a TIMBUSH position. In particular, it helps eliminating cases when we prove Lemma 3.13.

**Lemma 3.12** *Let  $w$  be a word starting with a  $C$  and ending with a  $J$  such that all dominoes are right-topplable except the first one. Then  $w$  contains a subword in  $L \cup R \cup E$ .*

**Proof.** If  $w_2 = J$ , then  $w_1w_2 = CJ \in E$ . Assume  $w_2 = Y$ . Let  $k = \min\{i \geq 3 \mid w_i \in \{Y, J\}\}$ . The index  $k$  is well-defined as  $w_{|w|} = J$ , and  $w_1w_2 \cdots w_k \in L$ . We can prove that  $w$  contains a subword in  $R$  if  $w_2 = D$  in a similar way.  $\square$

The next lemma gives a winning move toppling right when it exists and the word starts with a left-topplable domino (when the word starts with a right-topplable domino, toppling that domino is a winning move). We here assume the word contains no subword belonging to  $E$ , as removing them does not change the outcome of the position.

**Lemma 3.13** *Let  $w$  be a word with no element of  $E$  as a subword, that starts with a left-topplable domino. Let  $x$  be the leftmost occurrence of an element of  $L \cup R$  as a subword of  $w$  if one exists. Then:*

- if  $x \in L$ , Left is the only player having a winning move in  $w$  toppling rightward
- if  $x \in R$ , Right is the only player having a winning move in  $w$  toppling rightward
- if no such  $x$  exists, no player has a winning move in  $w$  toppling rightward.

**Proof.** First assume no element of  $L \cup R$  appears as a subword of  $w$ . As  $\{KY, KJ, KD, QY, QJ, QD\} \subset L \cup R \cup E$ , no  $K$  or  $Q$  domino can be followed by a right-topplable domino in  $w$ . If there was a  $J$  domino, the rightmost left-topplable domino at its left would be a  $C$  domino. But then, it would contain a subword in  $L \cup R \cup E$  by Lemma 3.12. And such a left-topplable domino exists as  $w_1$  is left-topplable. So there are no  $J$  domino in  $w$ . If Left topples a  $Y$  domino, the rightmost left-topplable domino at its left would be a  $C$  domino. If that  $C$  domino is not immediately followed by the  $Y$  domino Left toppled, it would be followed by a  $D$  domino, otherwise there would be a subword of  $w$  which is in  $L$ . Then, toppling that  $C$  domino is a winning move for Right. We can prove that toppling a  $D$  domino is not a winning move for Right in a similar way.

Now assume  $x$  exists and is in  $L$ . We show that toppling the rightmost domino of  $x$  is a winning move for Left. Let  $w'$  be the resulting position after this move. The position  $w'$  contains no element of  $L \cup R \cup E$  as a subword and starts with a left-topplable domino, so Right has no winning move toppling rightward. Hence, we can assume Right would topple a domino leftward. If Right topples a domino which is not part of  $x$ , Left topples the leftmost domino of  $x$ , which is a winning move. Otherwise,  $x = CYD^iY$  or  $CYD^iJ$  for some  $i$  and Right would have toppled the  $C$  domino, which leaves an  $\mathcal{L}$ -position. We now show that no Right's move toppling rightward in  $w$  is winning. By Lemma 3.11, if Right has a winning move toppling rightward, it would be by toppling the rightmost domino of  $x$ . But then, Left wins by toppling the leftmost domino of  $x$ .

We can prove that Right is the only player having a winning move toppling rightward if  $x$  exists and is in  $L$  in a similar way.  $\square$

**Example 3.14** Figure 3.6 gives three rows of dominoes, with the words coding it, each of them starting with a left-topplable domino and having no subword in  $E$ . On the first row, the leftmost apparition of a subword in  $L \cup R$  is  $KJ$ , so Left can win the game playing first by toppling that  $J$  domino. On the second row, the leftmost apparition of a subword in  $L \cup R$  is  $CDYYD$ , so Right can win the game playing first by toppling that last  $D$  domino. On the third row, the word contains no subword of  $L \cup R$ , so no player has a winning move toppling rightward. On the first two rows, that winning move is underlined, and the domino corresponding is pointed at. Note that there might be other winning moves toppling rightward, the second  $J$  of the first row for instance.

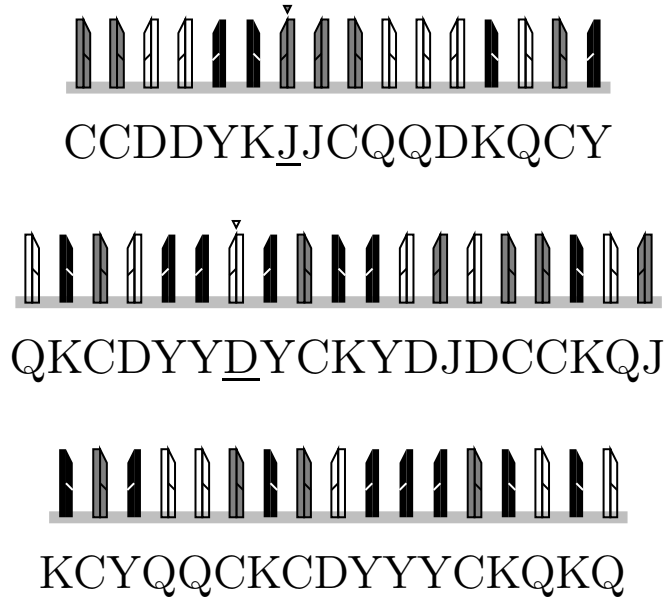
When a word starts with a right-topplable domino, choosing it is a winning move. Using that with Lemmas 3.11 and 3.13, we can find which player can win toppling a domino rightward. As the same observations can be made about left-topplable winning moves, we get the outcome of any word in linear time.

**Theorem 3.15** *We can compute the outcome of any word  $w$  in time  $O(|w|)$ .*

We end this study on paths by giving a characterisation of TIMBUSH  $\mathcal{P}$ -positions on paths.

**Theorem 3.16** *Let  $w$  be a word representing a TIMBUSH  $\mathcal{P}$ -position, such that no subword of  $w$  is in  $E$ . Then  $w$  is the empty word.*

**Proof.** Assume  $w$  is not the empty word. As it is a  $\mathcal{P}$ -position, it starts with a left-topplable domino, and it has no word of  $L$  or  $R$  as a subword. Therefore, we can prove, as in the proof of Lemma 3.13, that it contains no  $J$  domino. By symmetry, it does not contain any  $C$  domino. But neither



**Figure 3.6:** Words representing TIMBUSH positions with a winning move toppling rightward underlined when it exists

a  $K$  domino nor a  $Q$  domino can be followed by a right-topplable domino without  $w$  having a subword belonging to  $L \cup R \cup E$ . Hence all dominoes are left-topplable. But that would mean the last domino is left-topplable, and whoever plays it wins the game, contradicting the fact that  $w$  is a  $\mathcal{P}$ -position.

Hence  $w$  has to be the empty word.  $\square$

We can therefore count the number of TIMBUSH path  $\mathcal{P}$ -positions of length  $2n$ , given by the formula  $3^n c_n$ , where  $c_n$  is the  $n^{\text{th}}$  Catalan number  $\frac{(2n)!}{n!(n+1)!}$ , as well as conclude there would be no TIMBUSH path  $\mathcal{P}$ -positions of odd length.

### 3.1.3 Black and white trees

We now look at general orientations of trees again, but add a restriction on the colours used, by forbidding any arc to be coloured grey.

Note that directed graphs having no grey arc might have grey arcs that appear when reduced to orientations of forests using Theorem 3.4, if they contain a two-coloured cycle, but for such connected graphs, the outcome is always  $\mathcal{N}$ . It is also possible to get a black and white coloured orientation of a forest equivalent to the original graph by duplicating each grey arc with the leaf from which it originates, leaving a black arc and a white arc.

**Example 3.17** Figure 3.7 shows an example of a directed graph (on the left) and a corresponding forest (on the right), obtained after applying the

reduction from Theorem 3.4 and replacing each grey arc by a black arc and a white arc. Light grey areas surround the cycles, which are reduced to the grey vertices of the forest. The white vertices denote the vertices of degree 1 we add with an out-arc toward those grey vertices. When the 2-connected component is monochromatic, we only add one of these white vertices, whereas we add two if it contains both black arcs and white arcs. There might be several such forests depending on the choice of the component used for the reduction, but they all share the same value. Choosing maximal 2-connected components when reducing leads to a unique forest with least number of vertices.

Lemma 3.8 acts as Lemma 2.19, but we also need to find analogous of Lemma 2.18 and 2.21 to find the outcome of a black and white tree.

We first recall the definition of a leaf-path: a *leaf-path* is a path from a vertex  $x$  to a leaf  $y$ , with  $x \neq y$ , consisting only of vertices of degree 2, apart from  $y$  and possibly  $x$ .

The next lemma is analogous to Lemma 2.18, that is a way to find a winning move in a minimal position, though it may appear in non-minimal positions as well. Nevertheless, in a non-minimal position, we would need to find a winning move for each player to be able to stop the analysis without reducing any more.

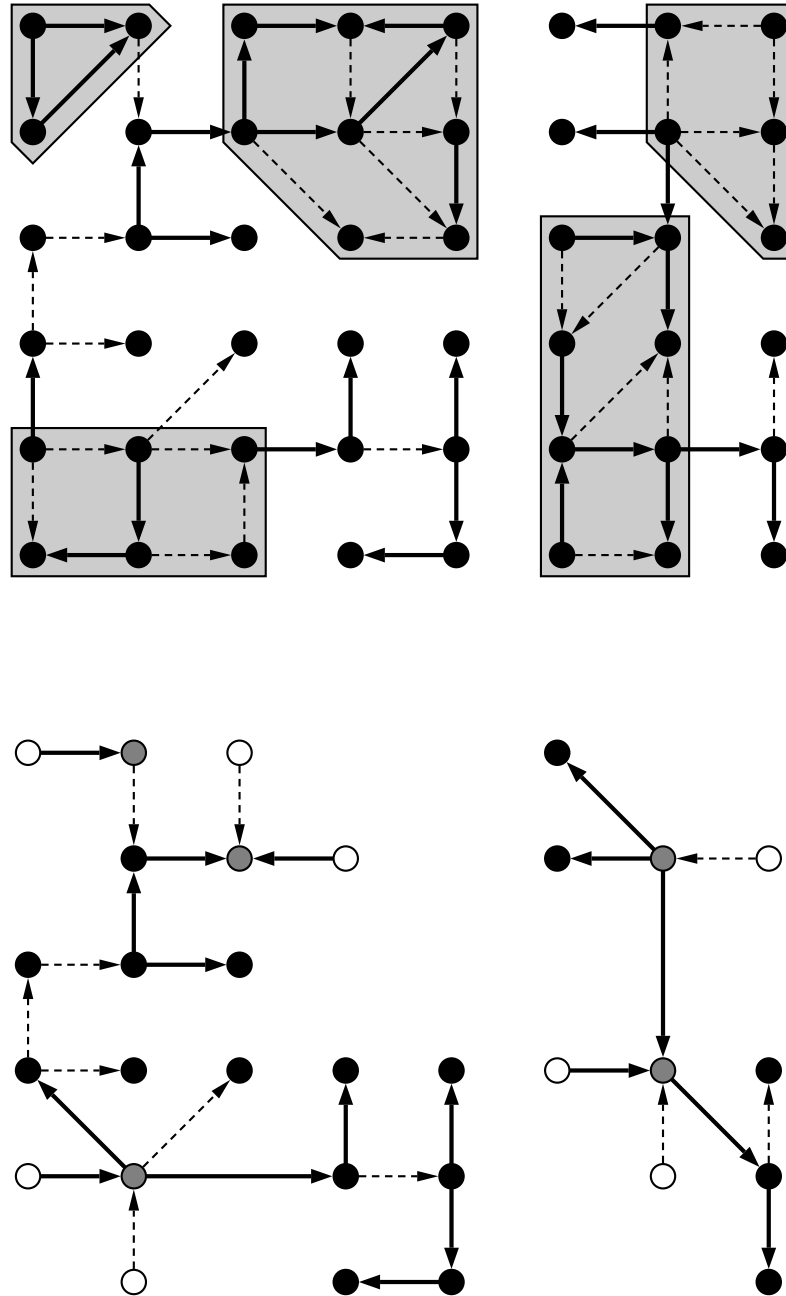
**Lemma 3.18** *Let  $T$  be a black and white coloured orientation of a tree such that there is a leaf  $v$  of  $T$  with out-degree 1 or a vertex  $u$  with in-degree 0 and out-degree 2 from which there is a leaf-path in which all arcs are directed toward the leaf. If all arcs incident with  $v$  or  $u$  are black, then  $T \in \mathcal{L}^+ \cup \mathcal{N}^+$ , that is Left wins the game playing first. If they are all white, then  $T \in \mathcal{R}^+ \cup \mathcal{N}^+$ .*

**Proof.** Assume we are in the first case, with the arc incident to  $v$  being black. Let  $x$  be the out-neighbour of  $v$ . If Left starts, she wins by toppling the domino on the arc  $(v, x)$ , as that move empties the graph.

Assume now we are in the second case, with the arcs incident to  $u$  being black. Let  $x$  be the out-neighbour of  $u$  further from the leaf considered in the leaf-path. If Left starts, she wins by toppling the domino on the arc  $(u, x)$ , as Right will never be able to remove the other arc incident to  $u$  and Left empties the graph when she plays it.

The proof of the cases where the arcs incident to  $v$  or  $u$  are white is similar.  $\square$

The next lemma is an analogous of Lemma 2.21, that is a way to transform two leaf-paths with all arcs directed towards the leaves into only one leaf-path. As in Lemma 2.21, the game after reduction is equivalent in normal play to the game before reduction.



**Figure 3.7:** A black and white TIMBUSH position and a corresponding black and white orientation of a forest



**Lemma 3.19** *Let  $T_0$  be a black and white coloured orientation of a tree,  $u \in V(T_0)$  a vertex, and  $n, m, \ell \in \mathbb{N}$  three integers. Let  $P_1$  (resp.  $P_2, P_3$ ) be a black and white coloured orientation of a path with vertex set*

$$\{x_i\}_{0 \leq i \leq n} \text{ (resp. } \{y_i\}_{0 \leq i \leq m}, \{z_i\}_{0 \leq i \leq \ell})$$

and arc set

$$\{(x_i, x_{i+1})\}_{0 \leq i \leq n-1} \text{ (resp. } \{(y_i, y_{i+1})\}_{0 \leq i \leq m-1}, \{(z_i, z_{i+1})\}_{0 \leq i \leq \ell-1}).$$

Let  $T$  be the position with vertex set

$$V(T) = V(T_0) \cup V(P_2) \cup V(P_3)$$

where  $u, y_0$  and  $z_0$  are identified and arc set

$$A(T) = A(T_0) \cup A(P_2) \cup A(P_3)$$

sharing the same colours as in  $T_0, P_2$  or  $P_3$ .

Let  $T'$  be the position with vertex set

$$V(T') = V(T_0) \cup V(P_1)$$

where  $u$  and  $x_0$  are identified and arc set

$$E(T') = E(T) \cup E(P_1)$$

sharing the same colours as in  $T_0$  or  $P_1$ .

Then  $o^+(T - T') = o^+(P_2 + P_3 - P_1)$ .

**Proof.** We prove it by induction on  $|V(T_0)| + n + m + \ell$ . If  $n + m + \ell = 0$ ,  $T = T_0 = T'$ ,  $P_1 = P_2 = P_3 = \{\cdot|\cdot\}$  and  $o^+(T - T') = \mathcal{P} = o^+(P_2 + P_3 - P_1)$ .

Assume now  $|V(T_0)| + n + m + \ell > 0$ . Assume Left has a winning move in  $P_2 + P_3 - P_1$ . She can play that move in  $T - T'$ , which is a winning move by induction hypothesis. Similarly, we can prove Right has a winning move in  $T - T'$  if he has one in  $P_2 + P_3 - P_1$ . Assume now Left has no winning move in  $P_2 + P_3 - P_1$ , i.e.  $P_2 + P_3 - P_1 \leq 0$ . Any directed edge of  $T_0$  is both in  $T$  and  $T'$ , thus if Left chooses such an edge in one of  $T$  or  $-T'$  then Right can choose the corresponding arc in  $-T'$  or  $T$ , which leaves either a  $\mathcal{P}$ -position if the move topples  $u$  or if  $P_2 + P_3 - P_1 = 0$  by induction, or an  $\mathcal{R}$ -position by induction otherwise. Assume Left chooses an arc of  $P_2, P_3$  or  $-P_1$  in the game  $T - T'$ . As these paths are numbers that only have numbers as options (by Berlekamp's rule [4]), it can only decrease the value of the remaining path, so it is a losing move by induction hypothesis. Similarly, we can prove Right has no winning move in  $T - T'$  if he has no winning move in  $P_2 + P_3 - P_1$ .  $\square$

By replacing two leaf-paths with all arcs directed towards the leaves by one leaf-path having the value of the sum of their values and all arcs directed towards its leaf, we therefore get an equivalent position. This replacement is always possible as a path with all arcs directed toward the same leaf can be seen as a HACKENBUSH string rooted on the vertex with in-degree 0 (and this transformation is a bijection); all black and white HACKENBUSH strings yield dyadic number values, and any dyadic number value can be obtained by a unique black and white HACKENBUSH string using Berlekamp's rule [4].

**Example 3.20** Figures 3.8 and 3.9 illustrate the reduction by giving an example of an orientation of a tree and its image after reduction. On the initial graph, Left can win by playing the  $a$  arc, but we still need to know if Right has a winning move to determine if it is an  $\mathcal{N}$ -position or an  $\mathcal{L}$ -position. The reduction from Lemma 3.8 cannot be applied, so we use the other reduction to get a smaller tree having the same outcome (even better, having the same value). Light grey areas on the first tree surround the leaf-paths we merge, and the reduction cannot be applied anywhere else on the first tree. Each of these leaf-paths starts with a grey vertex and all other vertices are white. The same pattern is used on the second tree to detect the new path obtained by merging those of the first tree. The reduction can again be applied on the second tree, on paths surrounded by light grey areas, and even the reduction from Lemma 3.8 on the arcs surrounded by the dark grey area.

Lemma 3.19 is true even if some of the arcs are grey, but in this case, it is not always possible to find a single leaf-path whose value is the sum of the two original ones.

As in Section 2.2, a position for which we cannot apply the reduction from Lemma 3.8 or Lemma 3.19 is called *minimal*. For the same reason as in Lemma 3.11, to have both players having in the same leaf-path a winning move toppling not toward the leaf of that leaf-path, it would have to be by toppling the same domino, which is not possible here since we are dealing with black and white TIMBUSH positions. From Lemma 3.18, we know what such a winning move looks like and Lemma 3.13 tells us that only leaf-paths satisfying hypothesis of Lemma 3.18 may have a winning move toppling the rest of the tree when the position is minimal. In a minimal position, a leaf-path where no player has a winning move not toppling toward the leaf must have all arcs directed toward the leaf, as otherwise we could reduce the game using Lemma 3.8. Therefore, we get the following lemma about  $\mathcal{P}$ -positions.

**Lemma 3.21** *A minimal position with outcome  $\mathcal{P}$  can only be a graph with no arc.*

**Proof.** Let  $T$  be a minimal position with at least one arc. If it has exactly one arc, it is obviously in  $\mathcal{L} \cup \mathcal{R}$ , depending of the arc colour, so we can assume  $T$  has at least two arcs. Then there exists a vertex  $w$  at which there

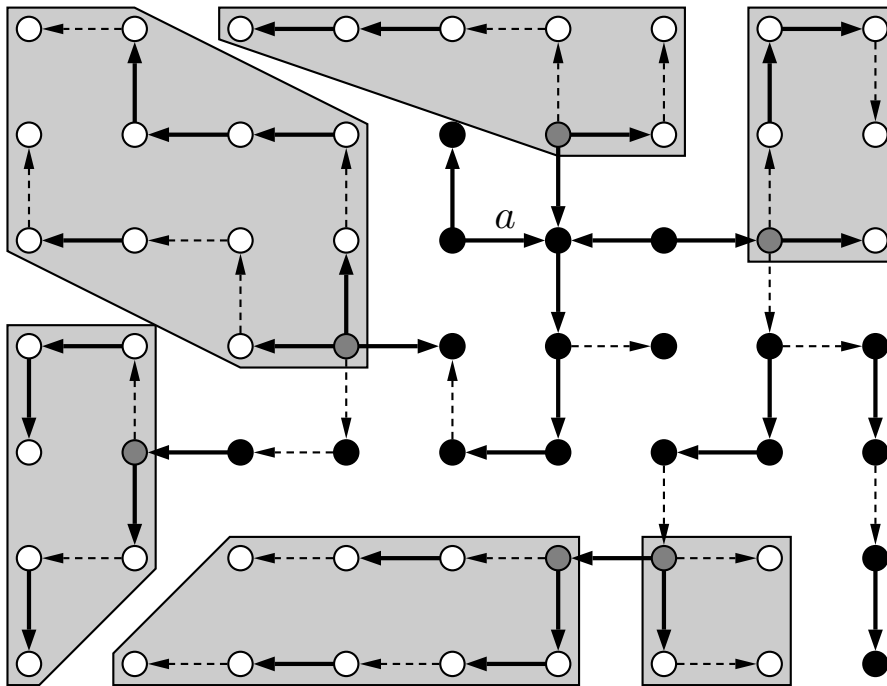


Figure 3.8: An orientation of a tree seen as a TIMBUSH position

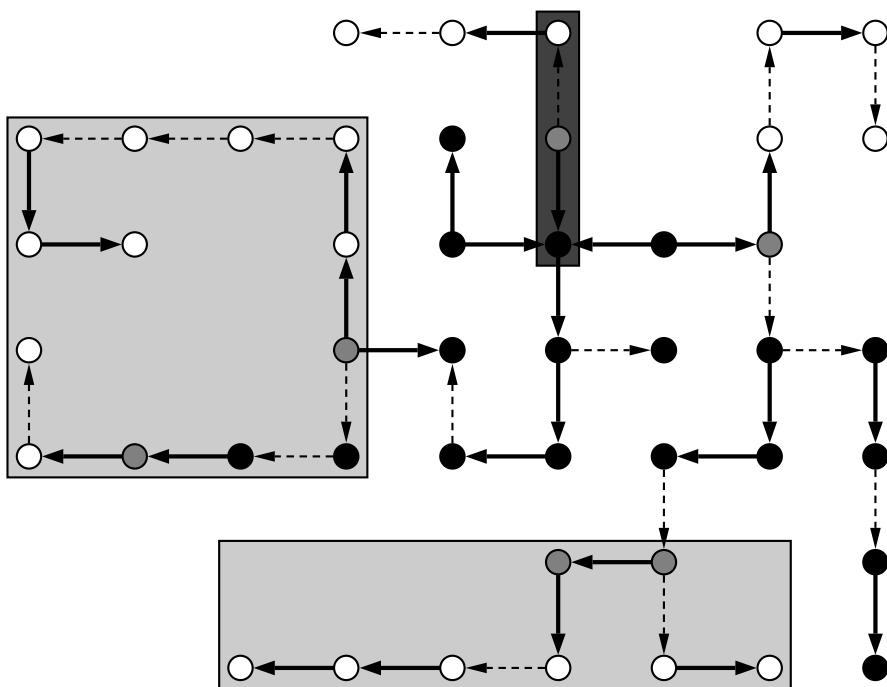


Figure 3.9: Its image after reduction, having the same outcome

are two leaf-paths  $\{x_i\}_{0 \leq i \leq n}$  and  $\{y_i\}_{0 \leq i \leq m}$  ( $x_0 = w = y_0$ ). If  $(x_n, x_{n-1})$  or  $(y_m, y_{m-1})$  is an arc, the player which can topple it can choose it and win playing first. Now assume both  $(x_{n-1}, x_n)$  and  $(y_{m-1}, y_m)$  are arcs. As  $T$  is minimal, it cannot be reduced using Lemma 3.8, so if one of  $(x_{i+1}, x_i)$ ,  $(y_{i+1}, y_i)$ ,  $(x_1, w)$  or  $(y_1, w)$  is an arc, the one with vertices of greater index, say  $(x_{i+1}, x_i)$ , has to share the colour of the arc  $(x_{i+1}, x_{i+2})$ . Then the player which can topple  $(x_{i+1}, x_i)$  can choose it and win playing first. Assume now all  $(x_i, x_{i+1})$ ,  $(y_i, y_{i+1})$ ,  $(w, x_1)$  and  $(w, y_1)$  are arcs. Then we can apply the reduction from Lemma 3.19, which is a contradiction.  $\square$

Finding the outcome of a minimal position now becomes a formality. If there is no arc, we are dealing with a  $\mathcal{P}$ -position. If there is just one arc, the outcome is  $\mathcal{L}$  if the arc is black and  $\mathcal{R}$  if it is white. When there are two arcs or more, we check in each leaf-path who has a winning move not toppling the leaf of that leaf-path. If both players have such a move, we are dealing with an  $\mathcal{N}$ -position. Otherwise, the only player who has such a move, and such a player exists since there is a vertex at which there are two leaf-paths and one of these paths has to yield such a winning move for the same reason as in the proof of Lemma 3.21 since the position is minimal, wins the game whether they play first or second. Indeed, if the other player does not play an arc of a leaf-path, it leaves a vertex at which there were two leaf-paths which are still there and where the former player can win; if they play on an arc of a leaf-path that topples toward the leaf of that leaf-path, the situation is the same unless the tree was a path from the beginning and Lemma 3.13 (and its counterpart on left-topplable winning moves) could conclude even before the move was played; if they play on an arc of a leaf-path that does not topple toward the leaf of that leaf-path, it cannot be a winning move by assumption. Note that the reduction from Lemma 3.8 decreases the number of vertices without increasing the number of leaves, and the reduction from Lemma 3.19 decreases the number of leaves without increasing the number of vertices, so they can only be applied a linear number of times. As finding where to apply the reduction can be done in linear time, this leads to a quadratic time algorithm.

**Theorem 3.22** *We can compute the outcome of any black and white connected oriented graph  $G$  in time  $O(|V(G)|^2)$ .*

Note that for a tree, the number of edges is equal to the number of vertices minus one, and the reduction to get an orientation of a tree from a connected oriented graph containing a cycle can be done in time  $O(|V(G)|^2)$ . Hence, we can consider  $O(|V(G)|) = O(|E(G)|)$  for the second part of the algorithm.

# LLRELER



Figure 3.10: A row of dominoes and the corresponding TIMBUSH position

---

## 3.2 TOPPLING DOMINOES

---

**TOPPLING DOMINOES** is a partizan game, introduced by Albert Nowakowski and Wolfe in [1], played on one or several rows of dominoes coloured black, white, or grey. On her move, Left chooses a black or grey domino and topples it with all dominoes (of the same row) at its left, or with all dominoes (of the same row) at its right. On his turn, Right does the same with a white or grey domino.

To describe a one row **TOPPLING DOMINOES** game, we just give the word formed by the colours of its dominoes read from left to right. The black, white and grey dominoes are also symbolised respectively by an L (for Left or bLack), an R (for Right  $\approx$  white) and an E (for Either or grEy). For example, LLERR represents a **TOPPLING DOMINOES** game with two black dominoes followed by a grey then two white dominoes.

A **TOPPLING DOMINOES** position with  $n$  dominoes can be seen as a **TIMBUSH** position on a path with  $2n$  arcs, each domino being represented by two arcs sharing the same colour (as the domino) pointing toward the same vertex. See Figure 3.10 for an example.

A first easy observation on **TOPPLING DOMINOES** is that the only game on one row that has outcome  $\mathcal{P}$  is the empty row. Indeed, if there is at least one domino, any player who can play a domino at one end of the line can win playing first. So if both extremities of the game are black, the game has outcome  $\mathcal{L}$ , if both are white, the game has outcome  $\mathcal{R}$ , otherwise the game has outcome  $\mathcal{N}$ . This uniqueness of the 0 game is rather unusual, and a natural question that arises is the following :

**Question 3.23** *In the game **TOPPLING DOMINOES**, are there many equivalence classes with a unique element consisting of only one row? Or are there many games with few representations in a single row?*

Some initial study of this question was given by Fink, Nowakowski, Siegel and Wolfe in [17]. They gave much credit to this question with the following result:

**Theorem 3.24 (Fink et al. [17])** *All numbers appear uniquely in **TOPPLING DOMINOES**, i.e. if two games  $G$  and  $G'$  have value a same number, then they are identical.*

A nice corollary of this result is that numbers in **TOPPLING DOMINOES** are necessarily palindromes, since they equal their reversal. In the following,

for a given number  $x$ , we denote by  $\mathbf{x}$  the unique TOPPLING DOMINOES game with value  $x$ .

Fink et al. conclude [17] with a series of conjectures, some of which are inspired by Theorem 3.24. They reformulate Theorem 3.24 as follows, explicitly describing for a number  $x$  the unique TOPPLING DOMINOES games with value  $x$ .

**Theorem 3.25 (Fink et al. [17])** *If a game  $G$  has value a number in canonical form  $\{a|b\}$ , then  $G$  is the TOPPLING DOMINOES game  $\mathbf{aLRb}$ .*

Their first conjecture was that a similar result is also true when  $a$  and  $b$  are numbers but not the resulting game:

**Conjecture 3.26 (Fink et al. [17])** *Let  $a$  and  $b$  be numbers with  $a \geq b$ , the game  $\{a|b\}$  is given (uniquely) by the TOPPLING DOMINOES game  $\mathbf{aLRb}$ .*

In the following, we settle this conjecture. We first prove that the game  $\mathbf{aLRb}$  is indeed the game  $\{a|b\}$ , but we then show that  $\mathbf{aEb}$  also has value  $\{a|b\}$ . However, we prove that there are no other TOPPLING DOMINOES game with that value, namely:

**Theorem 3.27** *Let  $a \geq b$  be numbers and  $G$  be a TOPPLING DOMINOES game. The value of  $G$  is  $\{a|b\}$  if and only if  $G$  is  $\mathbf{aLRb}$ ,  $\mathbf{aEb}$  or one of their reversals.*

The proof of this result is given in Subsection 3.2.2. Fink et al. proposed two similar conjectures in [17], for the games  $\{a|\{b|c\}\}$  and  $\{\{a|b\}|\{c|d\}\}$ .

**Conjecture 3.28 (Fink et al. [17])** *Let  $a$ ,  $b$  and  $c$  be numbers with  $a \geq b \geq c$ . The game  $\{a|\{b|c\}\}$  is given (uniquely) by the TOPPLING DOMINOES game  $\mathbf{aLRcRLb}$ .*

**Conjecture 3.29 (Fink et al. [17])** *Let  $a$ ,  $b$  and  $c$  be numbers with  $a \geq b \geq c \geq d$ . The game  $\{\{a|b\}|\{c|d\}\}$  is given (uniquely) by the TOPPLING DOMINOES game  $\mathbf{bRLaLRdRLc}$ .*

We propose the following results to settle the conjectures.

**Theorem 3.30** *If  $a \geq b \geq c$  are numbers, then  $\mathbf{aLRcRLb}$  has value  $\{a|\{b|c\}\}$ . Moreover, if  $a > b$ , then  $\mathbf{aEcRLb}$  also has value  $\{a|\{b|c\}\}$ .*

**Theorem 3.31** *If  $a \geq b > c \geq d$  are numbers, then both  $\mathbf{bRLaLRdRLc}$  and  $\mathbf{bRLaEdRLc}$  have value  $\{\{a|b\}|\{c|d\}\}$ .*

The proofs of these results are given respectively in Appendices B.1 and B.2, as they use the same kind of argument as the proof of Theorem 3.27.

Note also that Conjecture 3.29 is not true when  $b = c$ . Indeed, the game  $\{\{a|b\}|\{b|d\}\}$  has value  $b$ , and therefore has a unique representation by Theorem 3.24.

In the following, we prove Theorem 3.27, but first we prove in Subsection 3.2.1 some useful preliminary results.

### 3.2.1 Preliminary results

In the following, for a given TOPPLING DOMINOES game  $G$ , we denote by  $G^{L^+}$  (respectively  $G^{R^+}$ ) any game obtained from  $G$  by a sequence of Left moves (respectively of Right moves). We sometimes allow this sequence to be empty, and then use the notations  $G^{L^*}$  and  $G^{R^*}$ . We also often denote the canonical Left and Right options of a game  $x$  whose value is a number by  $x^{L_0}$  and  $x^{R_0}$  respectively.

In [17], Fink et al. proved the following :

**Theorem 3.32 (Fink et al. [17])** *For any TOPPLING DOMINOES game  $G$ ,*

$$LG > G.$$

Actually, when the game is a number  $\mathbf{x}$ , they also proved that  $\mathbf{x}^{L^+} < x$ . We extend both their results for numbers to the following lemma, involving a second number  $y$  not too far from  $x$ :

**Lemma 3.33** *Let  $x, y$  be numbers.*

- *If  $y < x + 1$ , or  $y < x^{R_0}$  when  $x$  is not an integer, then*

$$\begin{cases} y < L\mathbf{x} \\ y < \mathbf{x}^{R^+} \text{ for any game } \mathbf{x}^{R^+} \end{cases}$$

- *If  $x - 1 < y$ , or  $x^{L_0} < y$  when  $x$  is not an integer, then*

$$\begin{cases} \mathbf{x}R < y \\ \mathbf{x}^{L^+} < y \text{ for any game } \mathbf{x}^{L^+} \end{cases}$$

**Proof.** We give the proof for  $y < x + 1$  and for  $y < x^{R_0}$ , the proof for  $x - 1 < y$  and for  $x^{L_0} < y$  being similar. We prove the result by induction on the birthday of  $y$ , and the number of dominoes in  $x$ . When  $x = 0$ , the result is obvious.

Consider first the case when  $x$  is an integer, and let  $y$  be a number such that  $y < x + 1$ . Assume first  $x > 0$ . By Theorem 3.24, there is a unique TOPPLING DOMINOES game with value  $x$ , namely  $\mathbf{x} = L^x$ . We then get  $L\mathbf{x} = L^{x+1} = x + 1 > y$ . Moreover, there is no Right option to  $x$ . So the result holds. Assume now  $x < 0$ , that is  $\mathbf{x} = R^{|x|}$ . We have  $L\mathbf{x} = LR^{|x|} = \{0|x+1\}$  which is more than  $y$  since both Left and Right options are numbers and more than  $y$ . Moreover, any game  $\mathbf{x}^{R^+}$  is of the form  $R^k = -k$  with  $x + 1 \leq -k \leq 0$  so any such  $\mathbf{x}^{R^+}$  is more than  $y$ . So the result holds.

Consider now the case when  $x$  is a number but not an integer, of canonical form  $\{x^{L_0}|x^{R_0}\}$ . Let  $y$  be a number such that  $y < x^{R_0}$ . Recall that by Theorem 3.25,  $\mathbf{x} = \mathbf{x}^{L_0}LR\mathbf{x}^{R_0}$ . Note that  $x^{R_0} - x^{L_0} \leq 1$ , and when defined,  $(x^{L_0})^{R_0} \geq x^{R_0}$  and  $(x^{R_0})^{L_0} \leq x^{L_0}$ .

To prove  $Lx > y$ , we can just prove that whoever plays first, Left has a winning strategy in  $Lx - y = Lx^{L_0}LRx^{R_0} - y$ . When Left starts, she can move to  $Lx^{L_0} - y$ . Since  $x^{L_0}$  is born earlier than  $x$  and  $y < x^{R_0} \leq (x^{L_0})^{R_0}$  (or  $y < x^{R_0} \leq x^{L_0} + 1$  if  $x^{L_0}$  is an integer), we can use induction and get  $y < Lx^{L_0}$ . Thus  $Lx^{L_0} - y$  is positive and Left wins. Now consider the case when Right starts; we list all his possible moves from  $Lx - y = Lx^{L_0}LRx^{R_0} - y$ . If Right plays in  $-y$ , we get

- $Lx + (-y)^{R_0}$ . We have  $(-y)^{R_0} = -(y^{L_0})$  and  $y^{L_0} < y < x^{R_0}$ . Thus applying induction, we get  $Lx > y^{L_0}$  and thus  $Lx + (-y)^{R_0} > 0$ , so Left wins.

Suppose now Right moves in  $Lx^{L_0}LRx^{R_0}$ . Toppling rightward, Right can move to:

- $L(x^{L_0})^R - y$ . By Theorem 3.32,  $L(x^{L_0})^R - y > (x^{L_0})^R - y$ . Moreover, since  $y < x^{R_0} \leq (x^{L_0})^{R_0}$ , we have by induction  $(x^{L_0})^R > y$ . Thus  $L(x^{L_0})^R - y$  is positive and Left wins.
- $Lx^{L_0}L - y$  which is more that  $Lx^{L_0} - y$  by Theorem 3.32, which is positive as proved earlier. Thus Left wins.
- $Lx^{L_0}LR(x^{R_0})^R - y$ . Then Left can answer to  $Lx^{L_0} - y$  which again is positive as proved earlier, and win.

Toppling leftward, Right can move to:

- $(x^{L_0})^RLRx^{R_0} - y$ . Then Left can answer to  $(x^{L_0})^R - y$  which is positive as proved earlier.
- $x^{R_0} - y$ , positive by initial assumption.
- $(x^{R_0})^R - y$ . We have  $(x^{R_0})^{R_0} > x^{R_0} > y$ , so by induction  $(x^{R_0})^R > y$  and Left wins.

We now prove by induction that  $x^{R^+} > y$  for any  $x^{R^+}$ . A game  $x^{R^+} = (x^{L_0}LRx^{R_0})^{R^+}$  may take seven different forms, namely:

- $(x^{L_0})^{R^+}$ , larger than  $y$  by induction since  $(x^{L_0})^{R_0} \geq x^{R_0} > y$ .
- $(x^{L_0})^{R^+}L$ , which is larger than  $(x^{L_0})^{R^+}$ , thus also larger than  $y$ .
- $x^{L_0}L$ , larger than  $y$  by induction since  $(x^{L_0})^{R_0} \geq x^{R_0} > y$ .
- $(x^{R_0})^{R^+}$ , larger than  $y$  by induction since  $(x^{R_0})^{R_0} > x^{R_0} > y$ .
- $x^{R_0}$ , larger than  $y$  by our initial assumption.
- $(x^{L_0})^{R^+}LR(x^{R_0})^{R^*}$ . In this case, we show that Left has a winning move in  $(x^{L_0})^{R^+}LR(x^{R_0})^{R^*} - y$ . When playing first, she can move to  $(x^{L_0})^{R^+} - y$  that we already proved to be positive. When playing second, we may only consider Right's move to  $(x^{L_0})^{R^+}LR(x^{R_0})^{R^*} + (-y)^{R_0}$ , to which she answers similarly to  $(x^{L_0})^{R^+} + (-y)^{R_0}$ , also positive since  $(-y)^{R_0} > -y$ .
- $x^{L_0}LR(x^{R_0})^{R^+} = x'$ . If  $y \leq x^{L_0}$ , then Left wins in  $x' - y$  by playing to  $x^{L_0} - y$  or  $x^{L_0} + (-y)^{R_0}$ . Otherwise, we proceed by induction on



the birthday of  $y$  and the number of dominoes in  $\mathbf{x}'$ . If Right starts in  $\mathbf{x}'$ , we can use induction directly and get that Left wins. If he starts in  $-y$ , since  $(-y)^{R_0} > -y$ , we can also apply induction. Now if Left cannot win when starting, we have  $\mathbf{x}' - y$  is  $\mathcal{P}$ , so  $\mathbf{x}' = y$ . Yet,  $y$  is a number such that  $x^{L_0} < y < x^{R_0}$ , so  $y$  is not born earlier than  $x$ . So by Theorem 3.25,  $\mathbf{x}$  is a subword of  $\mathbf{y}$  and as  $\mathbf{x}'$  is a strict subword of  $\mathbf{x}$ ,  $\mathbf{x}' \neq \mathbf{y}$ . By unicity (Theorem 3.24),  $\mathbf{x}' \not\equiv^+ y$ , which yields a contradiction.  $\square$

This gives us the following corollary.

**Corollary 3.34** *If  $a \geq b \geq c \geq d$  are numbers, then  $\mathbf{a}^{R^+} > \{a|b\}$ ,  $\mathbf{a}^{R^+} > \{a|\{b|c\}\}$ ,  $\mathbf{a}^{R^+} > \{\{a|b\}|c\}$  and  $\mathbf{a}^{R^+} > \{\{a|b\}|\{c|d\}\}$ .*

**Proof.** By Lemma 3.33, we know that  $\mathbf{a}^{R^+} > \frac{a+a^{R_0}}{2}$  which itself is a number larger than  $a$ ,  $b$ ,  $c$  and  $d$ . The inequalities follow.  $\square$

### 3.2.2 Proof of Theorem 3.27

We now characterise the positions on one row having value  $\{a|b\}$ , for any numbers  $a \geq b$ . We start by proving that  $\mathbf{aLRb}$  is among those positions, and we first prove a preliminary lemma on options of  $\mathbf{aLRb}$ .

**Lemma 3.35** *Let  $a, b$  be numbers such that  $a \geq b$ . For any Right option  $\mathbf{b}^R$  obtained from  $\mathbf{b}$  toppling rightward, we have  $\mathbf{aLRb}^R > b$ .*

**Proof.** To prove that  $\mathbf{aLRb}^R > b$ , we can just prove that Left has a winning strategy in  $\mathbf{aLRb}^R - b$  whoever plays first. When Left starts, she can move to  $a - b$ , and since  $a - b \geq 0$ , reach a game which is  $\mathcal{P}$  or  $\mathcal{L}$ , thus win. Now consider the case when Right starts, and his possible moves from  $\mathbf{aLRb}^R - b$ . If Right plays in  $-b$ , we get

- $\mathbf{aLRb}^R + (-b)^R$ . Recall that since  $b$  is taken in its canonical form,  $-b$  has at most one Right option, namely  $(-b)^{R_0}$ . Here Left can answer to  $\mathbf{a} + (-b)^{R_0}$  which is positive since  $(-b)^{R_0} > -b \geq -a$ . Therefore it is a winning position for Left.

Consider now Right's possible moves in  $\mathbf{aLRb}^R$ . Toppling rightward, Right can move to:

- $\mathbf{a}^R - b$ . Using Lemma 3.33 with  $x = y = a$ , we get  $\mathbf{a}^R > a$ , and since  $a \geq b$ ,  $\mathbf{a}^R - b > 0$ .
- $\mathbf{aL} - b$ . Again, by Lemma 3.33,  $\mathbf{aL} - b > 0$  and Left wins.
- $\mathbf{aLR}(\mathbf{b}^R)^R - b$ . Then Left can answer to  $\mathbf{a} - b$ , leaving a game in  $\mathcal{L}$  or in  $\mathcal{P}$  since  $a - b \geq 0$ , thus win.

Toppling leftward, Right can move to:

- $\mathbf{a}^R \text{LRb}^R - b$ . Then Left can answer to  $\mathbf{a}^R - b$  which is positive as proved above.
- $\mathbf{b}^R - b$  which is positive by Lemma 3.33.
- $(\mathbf{b}^R)^R - b$ , again positive by Lemma 3.33.

□

We can now state the following claim.

**Claim 3.36** *Let  $a, b$  be numbers such that  $a \geq b$ . We have  $\mathbf{aLRb} = \{a|b\}$ .*

**Proof.** To prove that  $\mathbf{aLRb} = \{a|b\}$ , we prove that the second player has a winning strategy in  $\mathbf{aLRb} - \{a|b\}$ . Without loss of generality, we may assume Right starts the game, and consider his possible moves from  $\mathbf{aLRb} - \{a|b\}$ . If Right plays in  $-\{a|b\}$ , we get

- $\mathbf{aLRb} - a$ . Then Left can answer to  $\mathbf{a} - a$  which has value 0.

Consider now Right's possible moves in  $\mathbf{aLRb}$ . Toppling rightward, Right can move to:

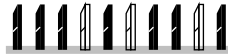
- $\mathbf{a}^R - \{a|b\}$ . Then Left can answer to  $\mathbf{a}^R - b$ , which is positive.
- $\mathbf{aL} - \{a|b\}$ , which is positive by Corollary 3.34.
- $\mathbf{aLRb}^R - \{a|b\}$ . Then Left can answer to  $\mathbf{aLRb}^R - b$ , which is positive by Lemma 3.35.

Toppling leftward, Right can move to:

- $\mathbf{a}^R \text{LRb} - \{a|b\}$ . Then Left can answer to  $\mathbf{a}^R - \{a|b\}$ , which is positive by Corollary 3.34.
- $\mathbf{b} - \{a|b\}$ . Then Left can answer to  $\mathbf{b} - b$  which has value 0.
- $b^R - \{a|b\}$ . Then Left can answer to  $\mathbf{b}^R - b$  which is positive.

□

As an example, here is a representation of  $\{2|\frac{3}{4}\}$ :



We now prove that  $\mathbf{aEb}$  also has value  $\{a|b\}$ , and we again need to prove first a preliminary lemma on options of  $\mathbf{aEb}$ .

**Lemma 3.37** *Let  $a, b$  be numbers such that  $a > b$ . For any Right option  $\mathbf{b}^R$  obtained from  $\mathbf{b}$  toppling rightward, we have  $\mathbf{aEb}^R > b$ .*

**Proof.** We prove that Left has a winning strategy in  $\mathbf{aEb}^R - b$  whoever plays first. When Left starts, she can move to  $a - b$ , reaching a game that is  $\mathcal{P}$  or  $\mathcal{L}$ , thus win. Now consider the case when Right starts, and his possible moves from  $\mathbf{aEb}^R - b$ . If Right plays in  $-b$ , we get

- $\mathbf{aEb}^R + (-b)^R$ . Recall that since  $b$  is taken in its canonical form, there is only one Right option to  $-b$ , namely  $(-b)^{R_0}$ . Here Left can answer to  $\mathbf{a} + (-b)^{R_0}$  which is positive since  $(-b)^{R_0} > -b \geq -a$ . Therefore it is a winning position for Left.

Consider now Right's possible moves in  $\mathbf{aEb}^R$ . Toppling rightward, Right can move to:

- $\mathbf{a}^R - b$ , which is positive.
- $\mathbf{a} - b$ , which is positive.
- $\mathbf{aE}(\mathbf{b}^R)^R - b$ . Then Left can answer to  $\mathbf{a} - b$  which is positive and win.

Toppling leftward, Right can move to:

- $\mathbf{a}^R\mathbf{Eb}^R - b$ . Then Left can answer to  $\mathbf{a}^R - b$ , which is positive.
- $\mathbf{b}^R - b$  which is positive.
- $(\mathbf{b}^R)^R - b$ , again positive.

□

We can now state the following claim.

**Claim 3.38** *Let  $a, b$  be numbers such that  $a \geq b$ . We have  $\mathbf{aEb} = \{a|b\}$ .*

**Proof.** To prove that  $\mathbf{aEb} = \{a|b\}$ , we prove that the second player has a winning strategy in  $\mathbf{aEb} - \{a|b\}$ . Without loss of generality, we may assume Right starts the game, and consider his possible moves from  $\mathbf{aEb} - \{a|b\}$ . If Right plays in  $-\{a|b\}$ , we get

- $\mathbf{aEb} - a$ . Then Left can answer to  $\mathbf{a} - a = 0$ .

Consider now Right's possible moves in  $\mathbf{aEb}$ . Toppling leftward, Right can move to:

- $\mathbf{a}^R\mathbf{Eb} - \{a|b\}$ . Then Left can answer to  $\mathbf{a}^R - \{a|b\}$ , which is positive by Corollary 3.34.
- $\mathbf{b} - \{a|b\}$ . Then Left can answer to  $\mathbf{b} - b$ , which has value 0.
- $\mathbf{b}^R - \{a|b\}$ . Then Left can answer to  $\mathbf{b}^R - b$ , which is positive.

Toppling rightward, Right can move to:

- $\mathbf{a}^R - \{a|b\}$ . Then Left can answer to  $\mathbf{a}^R - b$ , which is positive.
- $\mathbf{a} - \{a|b\}$ . Then Left can answer to  $\mathbf{a} - b$ , having value at least 0.
- $\mathbf{aEb}^R - \{a|b\}$ . Then if  $a > b$  Left can answer to  $\mathbf{aEb}^R - b$ , which is positive by Lemma 3.37. Otherwise,  $a = b$  and Left can answer to  $\mathbf{b}^R - \{a|b\}$ , which is positive by Corollary 3.34.

□

As an example, here is a representation of  $\{\frac{1}{2} | -\frac{5}{4}\}$ :



We now start proving these two rows of dominoes (and their reversals) are the only rows having the value  $\{a|b\}$ . The next four lemmas are preliminary lemmas, proving some options may not occur for a player in a game having value  $\{a|b\}$ .

First we prove that some of Left's moves from  $\mathbf{aLRb}$  cannot be available for Right in a game having value  $\{a|b\}$ .

**Lemma 3.39** *Let  $a, b$  be numbers such that  $a \geq b$ . For any Left option  $\mathbf{b}^L$  obtained from  $\mathbf{b}$  toppling rightward, we have  $\mathbf{aLRb}^L < \{a|b\}$ .*

**Proof.** We prove that Right has a winning strategy in  $\mathbf{aLRb}^L - \{a|b\}$  whoever plays first. When Right starts, he can move to  $b^L - \{a|b\}$ , which is negative by Corollary 3.34. Now consider the case when Left starts and her possible moves to  $\mathbf{aLRb}^L - \{a|b\}$ . If Left plays in  $-\{a|b\}$ , we get

- $\mathbf{aLRb}^L - b$ . Then Right can answer to  $b^L - b$ , which is negative.

Consider now Left's possible moves in  $\mathbf{aLRb}^L$ . Toppling rightward, Left can move to:

- $\mathbf{a}^L - \{a|b\}$ . Then Right can answer to  $\mathbf{a}^L - a$ , which is negative.
- $\mathbf{a} - \{a|b\}$ . Then Right can answer to  $a - a$  which has value 0.
- $\mathbf{aLR}(\mathbf{b}^L)^L - \{a|b\}$ . Then Right can answer to  $\mathbf{aLR}(\mathbf{b}^L)^L - a$ , which is negative by Lemma 3.35 since both moves in  $\mathbf{b}$  were by toppling rightward, allowing us to consider  $\mathbf{aLR}(\mathbf{b}^L)^L$  as some  $\mathbf{aLRb}^L$ .

Toppling leftward, Left can move to:

- $\mathbf{a}^L\mathbf{LRb}^L - \{a|b\}$ . Then Right can answer to  $\mathbf{b}^L - \{a|b\}$  which is negative by Corollary 3.34.
- $R\mathbf{b}^L - \{a|b\}$  which is negative as  $R\mathbf{b}^L < \mathbf{b}^L$  by Lemma 3.33 and  $\mathbf{b}^L - \{a|b\}$  is negative by Corollary 3.34.
- $(\mathbf{b}^L)^L - \{a|b\}$  which is negative by Corollary 3.34.

□

Now we prove that some of Right's moves from  $\mathbf{aLRb}$  cannot be available for Left in a game having value  $\{a|b\}$ . Note that these moves are not the reversal of moves considered in the previous lemma.

**Lemma 3.40** *Let  $a, b$  be numbers such that  $a \geq b$ . For any Right option  $\mathbf{b}^R$  obtained from  $\mathbf{b}$  toppling rightward, we have  $\mathbf{aLRb}^R > \{a|b\}$ .*

**Proof.** We prove that Left has a winning strategy in  $\mathbf{aLRb}^R - \{a|b\}$  whoever plays first. When Left starts, she can move to  $\mathbf{aLRb}^R - b$ , which is positive by Lemma 3.35. Now consider the case where Right starts, and his possible moves from  $\mathbf{aLRb}^R - \{a|b\}$ . If Right plays in  $\{a|b\}$ , we get

- $\mathbf{aLRb}^R - a$ . Then Left can answer to  $\mathbf{a} - a$  which has value 0.

Consider now Right's possible moves in  $\mathbf{aLRb}^R$ . Toppling rightward, Right can move to:

- $\mathbf{a}^R - \{a|b\}$ . Then Left can answer to  $\mathbf{a}^R - b$ , which is positive.
- $\mathbf{aL} - \{a|b\}$ , which is positive by Corollary 3.34.
- $\mathbf{aLR}(\mathbf{b}^R)^R - \{a|b\}$ . Then Left can answer to  $\mathbf{aLR}(\mathbf{b}^R)^R - b$ , which is positive by Lemma 3.35 since both moves in  $\mathbf{b}$  were by toppling rightward, allowing us to consider  $\mathbf{aLR}(\mathbf{b}^R)^R$  as some  $\mathbf{aLRb}^R$ .

Toppling leftward, Right can move to:

- $\mathbf{a}^R \text{LRb}^R - \{a|b\}$ . Then Left can answer to  $\mathbf{a}^R - \{a|b\}$ , which is positive by Corollary 3.34.
- $\mathbf{b}^R - \{a|b\}$ . Then Left can answer to  $\mathbf{b}^R - b$ , which is positive.
- $(\mathbf{b}^R)^R - \{a|b\}$ . Then Left can answer to  $(\mathbf{b}^R)^R - b$ , which is positive.

□

Similarly, we prove that some of Left's moves from  $\mathbf{aEb}$  cannot be available for Right in a game having value  $\{a|b\}$ .

**Lemma 3.41** *Let  $a, b$  be numbers such that  $a \geq b$ . For any Left option  $\mathbf{b}^L$  obtained from  $\mathbf{b}$  toppling rightward, we have  $\mathbf{aEb}^L < \{a|b\}$ .*

**Proof.** We prove that Right has a winning strategy in  $\mathbf{aEb}^L - \{a|b\}$  whoever plays first. When Right starts, he can move to  $\mathbf{b}^L - \{a|b\}$ , which is negative by Corollary 3.34. Now consider the case when Left starts, and her possible moves from  $\mathbf{aEb}^L - \{a|b\}$ . If Left plays in  $-\{a|b\}$ , we get

- $\mathbf{aEb}^L - b$ . Then Right can answer to  $\mathbf{b}^L - b$ , which is negative.

Consider now Right's possible moves in  $\mathbf{aEb}^L$ . Toppling rightward, Left can move to:

- $\mathbf{a}^L - \{a|b\}$ . Then Right can answer to  $\mathbf{a}^L - a$ , which is negative.
- $\mathbf{a} - \{a|b\}$ . Then Right can answer to  $\mathbf{a} - a$  which has value 0.
- $\mathbf{aE}(\mathbf{b}^L)^L - \{a|b\}$ . Then Right can answer to  $\mathbf{aE}(\mathbf{b}^L)^L - b$ , which is negative by Corollary 3.34 since both moves in  $\mathbf{b}$  were by toppling rightward, allowing us to consider  $\mathbf{aE}(\mathbf{b}^L)^L$  as some  $\mathbf{aEb}^L$ .

Toppling leftward, Left can move to:

- $\mathbf{a}^L \text{Eb}^L - \{a|b\}$ . Then Right can answer to  $\mathbf{b}^L - \{a|b\}$ , which is negative by Corollary 3.34.
- $\mathbf{b}^L - \{a|b\}$ , negative by Corollary 3.34.
- $(\mathbf{b}^L)^L - \{a|b\}$ , negative by Corollary 3.34.

□

Finally we prove that some of Right's moves from  $\mathbf{aEb}$  cannot be available for Left in a game having value  $\{a|b\}$ . Note that again these moves are not the reversal of moves considered in the previous lemma.

**Lemma 3.42** *Let  $a, b$  be numbers such that  $a \geq b$ . For any Right option  $\mathbf{b}^R$  obtained from  $\mathbf{b}$  toppling rightward, we have  $\mathbf{aEb}^R > \{a|b\}$ .*

**Proof.** We prove that Left has a winning strategy in  $\mathbf{aEb}^R - \{a|b\}$  whoever plays first. When Left starts, she can move to  $\mathbf{aEb}^R - b$ , which is positive by Lemma 3.37 if  $a > b$  and to  $\mathbf{b}^R - \{a|b\}$ , which is positive by Corollary 3.34 if  $a = b$ . Now consider the case when Right starts, and his possible moves from  $\mathbf{aEb}^R - \{a|b\}$ . If Right plays in  $-\{a|b\}$ , we get

- $\mathbf{aEb}^R - a$ . Then Left can answer to  $\mathbf{a} - a$  which has value 0.

Consider now Right's possible moves in  $\mathbf{aEb}^R$ . Toppling rightward, Right can move to:

- $\mathbf{a}^R - \{a|b\}$ . Then Left can answer to  $\mathbf{a}^R - b$ , which is positive.
- $\mathbf{a} - \{a|b\}$ . Then Left can answer to  $a - a$  which has value 0.
- $\mathbf{aE}(\mathbf{b}^R)^R - \{a|b\}$ . Then Left can answer to  $\mathbf{aE}(\mathbf{b}^R)^R - b$ , which is positive by Lemma 3.37 since both moves in  $\mathbf{b}$  were by toppling rightward, allowing us to consider  $\mathbf{aE}(\mathbf{b}^R)^R$  as some  $\mathbf{aEb}^R$ .

Toppling leftward, Right can move to:

- $\mathbf{a}^R\mathbf{Eb}^R - \{a|b\}$ . Then Left can answer to  $\mathbf{a}^R - \{a|b\}$ , which is positive by Corollary 3.34.
- $\mathbf{b}^R - \{a|b\}$ . Then Left can answer to  $\mathbf{b}^R - b$ , which is positive.
- $(\mathbf{b}^R)^R - \{a|b\}$ . Then Left can answer to  $(\mathbf{b}^R)^R - b$ , which is positive.

□

Though we want to deal with a game having value  $\{a|b\}$ , it might not be in canonical form, that is its options and other proper followers might not be numbers. As most known results in TOPPLING DOMINOES are about numbers, we get back there with the following lemma.

**Lemma 3.43** *Let  $a$  be a number and  $x$  be a game such that  $x \geq a$ . Then there exists a number  $b \geq a$  such that  $b \in x^{\mathbf{L}^*}$ .*

**Proof.** We prove it by induction on the birthdays of  $x$  and  $a$ .

If  $x = a$ , then  $a \in x^{\mathbf{L}^*}$  and  $a \geq a$ . Otherwise,  $x > a$ , so  $a^{R_0} \leq x$  or  $a \leq x^L$  for some  $x^L$ . In both cases, we conclude by induction hypothesis, since  $a^{R_0} > a$  and  $(x^L)^{\mathbf{L}^*} \subseteq x^{\mathbf{L}^*}$ . □

To fully characterise TOPPLING DOMINOES rows having value  $\{a|b\}$ , we need another lemma from [17]:

**Lemma 3.44 (Fink et al. [17]) [Sandwich Lemma]** *Let  $G$  be a TOPPLING DOMINOES position with value  $\alpha$ . From  $G - \alpha$ , if the first player topples dominoes toward the left (right) then the winning response is not to topple a domino toward the left (right).*

We now assume some TOPPLING DOMINOES position  $\mathbf{x}$  has value  $\{a|b\}$  to force some properties on such positions.

**Lemma 3.45** *If  $a \geq b$  are numbers and  $\mathbf{x}$  is a TOPPLING DOMINOES position with value  $\{a|b\}$ , then*

- $\mathbf{a} \in \mathbf{x}^L \cup \mathbf{x}^{\mathbf{L}^2}$ ,
- for any number  $a_0 > a$ ,  $a_0 \notin \mathbf{x}^{\mathbf{L}^*}$ ,
- $\mathbf{b} \in \mathbf{x}^R \cup \mathbf{x}^{\mathbf{R}^2}$ ,
- for any number  $b_0 < b$ ,  $b_0 \notin \mathbf{x}^{\mathbf{R}^*}$ .

**Proof.** As  $\mathbf{x} = \{a|b\}$ ,  $\mathbf{x} - \{a|b\}$  is a second-player win. From  $\mathbf{x} - \{a|b\}$ , Right can move to  $\mathbf{x} - a$ , from which Left should have a winning move. It cannot be to  $\mathbf{x} + (-a)^{L_0} = \{a|b\} - a^{R_0}$  as it is not winning since  $a^{R_0}$  can be written  $\{r_1|r_2\}$  with  $r_1 > a$  and  $r_2 > b$ . Hence there is a Left move  $\mathbf{x}_0$  of  $\mathbf{x}$  such that  $\mathbf{x}_0 \geq a$ . By Lemma 3.43, there exists a number  $a_0 \geq a$  such that  $\mathbf{a}_0 \in \mathbf{x}_0^{L^*} \subset \mathbf{x}^{L^+}$ . If  $\mathbf{a}_0 \in \mathbf{x}^L$ , then  $a_0 = a$  as otherwise Left's move from  $\mathbf{x} - \{a|b\}$  to  $\mathbf{a}_0 - \{a|b\}$  would be winning. As  $\mathbf{x}^{L^{\geq 3}} \subset \mathbf{x}^{L^2}$ , we do not need consider that case. Thus we can assume  $\mathbf{a}_0 \in \mathbf{x}^{L^2} \setminus \mathbf{x}^L$ . We can then write  $\mathbf{x} = \mathbf{w}_1 \delta_1 \mathbf{a}_0 \delta_2 \mathbf{w}_2$  with  $\delta_1, \delta_2 \in \{L, E\}$ . In the following, we use the fact that Left has no winning first move in  $\mathbf{x} - \{a|b\}$ . From  $\mathbf{x} - \{a|b\}$ , Left can topple  $\delta_2$  rightward to  $\mathbf{w}_1 \delta_1 \mathbf{a}_0$ . If Right answers to  $\mathbf{w}_1 \delta_1 \mathbf{a}_0 - a$ , Left can topple  $\delta_1$  leftward to  $\mathbf{a}_0 - a$  and win. Hence Right's winning answer has to be to some  $(\mathbf{w}_1 \delta_1 \mathbf{a}_0)^R - \{a|b\}$  and can only be achieved by toppling leftward by Lemma 3.44. If he moves to  $\mathbf{a}_0$  or some  $\mathbf{a}_0^R$ , Left's move to  $\mathbf{a}_0 - b$  or  $\mathbf{a}_0^R - b$  is a winning move since  $\mathbf{a}_0^R > \mathbf{a}_0 \geq a \geq b$ . Hence his winning move is to some  $\mathbf{w}_1^R \delta_1 \mathbf{a}_0 - \{a|b\}$ . But then Left can answer to  $\mathbf{a}_0 - \{a|b\}$  and we have  $a_0 = a$  or Right would have no winning strategy. This implies both that  $\mathbf{a} \in \mathbf{x}^L \cup \mathbf{x}^{L^2}$ , and that for any number  $a_0 > a$ ,  $a_0 \notin \mathbf{x}^{L^*}$ .

A similar reasoning would prove the last two stated items.  $\square$

**Lemma 3.46** *If  $a \geq b$  are numbers and  $\mathbf{x}$  is a TOPPLING DOMINOES position with value  $\{a|b\}$ , then  $\mathbf{x}$  has a Left option to  $\mathbf{a}$  or a Right option to  $\mathbf{b}$ .*

**Proof.** By Lemma 3.45, we know that  $\mathbf{a} \in \mathbf{x}^L \cup \mathbf{x}^{L^2}$  and  $\mathbf{b} \in \mathbf{x}^R \cup \mathbf{x}^{R^2}$ . Assume that  $\mathbf{a}$  only appears in  $\mathbf{x}^{L^2} \setminus \mathbf{x}^L$  and  $\mathbf{b}$  only appears in  $\mathbf{x}^{R^2} \setminus \mathbf{x}^R$ . We can write  $\mathbf{x} = \mathbf{w}_1 \delta_1 \mathbf{a} \delta_2 \mathbf{w}_2$  such that  $\mathbf{b} \notin \mathbf{w}_1^{R^+}$  and  $\delta_1, \delta_2 \in \{L, E\}$ , or  $\mathbf{x} = \mathbf{w}_1 \delta_1 \mathbf{b} \delta_2 \mathbf{w}_2$  such that  $\mathbf{a} \notin \mathbf{w}_1^{L^+}$  and  $\delta_1, \delta_2 \in \{R, E\}$ . Consider the one with  $\mathbf{w}_1$  having the smallest length. Without loss of generality, we can assume it is  $\mathbf{w}_1 \delta_1 \mathbf{a} \delta_2 \mathbf{w}_2$ , and consider Left's move from  $\mathbf{x} - \{a|b\}$  to  $\mathbf{w}_1 \delta_1 \mathbf{a} - \{a|b\}$ . We saw in the proof of Lemma 3.45 that Right's winning answer can only be to some  $\mathbf{w}_1^R \delta_1 \mathbf{a} - \{a|b\}$ . Now Left can move to  $\mathbf{w}_1^R \delta_1 \mathbf{a} - b$ . If Right answers to  $\mathbf{w}_1^R \delta_1 \mathbf{a} - b^{L_0}$ , Left can move to  $\mathbf{a} - b^{L_0}$  and win. Hence Right's winning answer has to be to some  $(\mathbf{w}_1^R \delta_1 \mathbf{a})^R - b$ . For this move to be winning, we have  $(\mathbf{w}_1^R \delta_1 \mathbf{a})^R \leq b$ , so by Lemma 3.43 we have  $\mathbf{b}_0 \in ((\mathbf{w}_1^R \delta_1 \mathbf{a})^R)^{R^*}$  for some number  $b_0 \leq b$ . If  $b_0 < b$ , by Lemma 3.45 we have  $b_0 \notin \mathbf{x}^{R^*}$ , so  $\mathbf{b}_0$  has to be obtained from  $\mathbf{w}_1^R \delta_1 \mathbf{a}$  by only toppling leftward. We have  $b_0 < b \leq a$ , hence  $\mathbf{b}_0$  cannot be some  $\mathbf{a}^R > \mathbf{a}$ , nor some  $(\mathbf{w}_1^R)^R \delta_1 \mathbf{a}$  since it would mean that  $\mathbf{a} \in \mathbf{b}_0^L$  and then  $\mathbf{a} < \mathbf{b}_0$ . Hence  $b_0 = b$ . Again,  $\mathbf{b}$  has to be obtained from  $\mathbf{w}_1^R \delta_1 \mathbf{a}$  by only toppling leftward since  $\mathbf{b} \notin \mathbf{a}^{R^+}$  as  $b \leq a$ , and no  $\mathbf{b}$  starts in  $\mathbf{x}$  before  $\mathbf{w}_1$  ends. In particular,  $(\mathbf{w}_1^R \delta_1 \mathbf{a})^R$  is of the form  $\mathbf{w}_1^R \delta_1 \mathbf{a}$ ,  $\mathbf{a}$  or  $\mathbf{a}^R$ .  $(\mathbf{w}_1^R \delta_1 \mathbf{a})^R$  cannot be of the form  $\mathbf{a}^R$ , since  $\mathbf{a}^R > \mathbf{a} \geq b$ . If  $(\mathbf{w}_1^R \delta_1 \mathbf{a})^R$  is of the form  $\mathbf{w}_1^R \delta_1 \mathbf{a}$ , Left can move from  $\mathbf{w}_1^R \delta_1 \mathbf{a} - b$  to  $\mathbf{a} - b$  and win. Hence  $(\mathbf{w}_1^R \delta_1 \mathbf{a})^R = \mathbf{a}$ , since  $(\mathbf{w}_1^R \delta_1 \mathbf{a})^R \leq b \leq a$ ,

we have  $a = b$  and  $\delta_1 = E$ .  $\mathbf{w}_1$  cannot be greater than or equal to  $a$  since otherwise we would find a number  $a_0 \geq a$  such that  $\mathbf{a}_0 \in \mathbf{w}_1^{L*}$ . Similarly,  $\mathbf{w}_1$  cannot be less than or equal to  $b = a$ . As  $a^L < a < a^R$ , there exists a Left move  $\mathbf{w}_1^L$  of  $\mathbf{w}_1$  that is greater than or equal to  $a$  and so we can find a number  $a_0 \geq a$  such that  $\mathbf{a}_0 \in (\mathbf{w}_1^L)^{L*}$ , which again is not possible. This means there was no winning move for Right from  $\mathbf{w}_1^R \delta_1 \mathbf{a} - b$ , which means there was no winning move for Right from  $\mathbf{w}_1 \delta_1 \mathbf{a} - \{a|b\}$ , which contradicts the fact that  $\mathbf{x} = \{a|b\}$ . Hence we have that  $\mathbf{a} \in \mathbf{x}^L$  or  $\mathbf{b} \in \mathbf{x}^R$ .  $\square$

We can now prove the following claim.

**Claim 3.47** *If  $a \geq b$  are numbers and  $\mathbf{x}$  is a TOPPLING DOMINOES position with value  $\{a|b\}$ , then  $\mathbf{x}$  is either  $\mathbf{aLRb}$  or  $\mathbf{aEb}$  (or the reversal of one of them).*

**Proof.** By Lemma 3.46, we can assume without loss of generality that  $\mathbf{x} = \mathbf{aLx}'$  or  $\mathbf{x} = \mathbf{aEx}'$  for some  $\mathbf{x}'$ .

First assume  $\mathbf{x} = \mathbf{aLx}'$ . If  $\mathbf{x}$  is a strict subword of  $\mathbf{aLRb}$ , then  $\mathbf{x}$  is an option of  $\mathbf{aLRb}$ , so they cannot be equal. For the same reason,  $\mathbf{aLRb}$  cannot be a strict subword of  $\mathbf{x}$ . Looking from left to right, we find the first domino where  $\mathbf{x}$  differs from  $\mathbf{aLRb}$ . If it is a white or grey domino instead of a black one, then Right has a move from  $\mathbf{x} - \{a|b\}$  to  $\mathbf{aLRb}^L - \{a|b\}$  which is winning by Lemma 3.39. If it is a black or grey domino instead of a white one, then Left has a move from  $\mathbf{x} - \{a|b\}$  to  $\mathbf{aL} - \{a|b\}$  or to  $\mathbf{aLRb}^R - \{a|b\}$  which are winning by Corollary 3.34 and Lemma 3.40. So  $\mathbf{x}$  cannot differ from  $\mathbf{aLRb}$ .

Now assume  $\mathbf{x} = \mathbf{aEx}'$ . If  $\mathbf{x}$  is a strict subword of  $\mathbf{aEb}$ , then  $\mathbf{x}$  is an option of  $\mathbf{aEb}$ , so they cannot be equal. For the same reason,  $\mathbf{aEb}$  cannot be a strict subword of  $\mathbf{x}$ . Looking from left to right, we find the first domino where  $\mathbf{x}$  differs from  $\mathbf{aEb}$ . If it is a white or grey domino instead of a black one, then Right has a move from  $\mathbf{x} - \{a|b\}$  to  $\mathbf{aEb}^L - \{a|b\}$  which is winning by Lemma 3.41. If it is a black or grey domino instead of a white one, then Left has a move from  $\mathbf{x} - \{a|b\}$  to  $\mathbf{aEb}^R - \{a|b\}$  which is winning by Lemma 3.42. So  $\mathbf{x}$  cannot differ from  $\mathbf{aEb}$ .  $\square$

---

### 3.3 COL

---

COL is a partizan game played on an undirected graph with vertices either uncoloured or coloured black or white. A move of Left consists in choosing an uncoloured vertex and colouring it black, while a move of Right would be to do the same with the colour white. An extra condition is that the partial colouring has to stay proper, that is no two adjacent vertices should have the same colour.



Uncoloured vertices are represented grey.

When a player chooses a vertex, they thus become unable to play on any of its neighbours for the rest of the game. Hence, all these neighbours are somehow reserved for the other player. Another way of seeing the game is to play it on the graph of available moves: a position is an undirected graph with all vertices coloured black, white or grey; a move of Left is to choose a black or grey vertex, remove it from the game with all its black coloured neighbours, and change the colour of its other neighbours to white; a move of Right is to choose a white or grey vertex, remove it from the game with all its white coloured neighbours, and change the colour of its other neighbours to black. This means that black vertices are reserved for Left, white vertices for Right, and either player can choose grey vertices. In the following, we use that second representation.

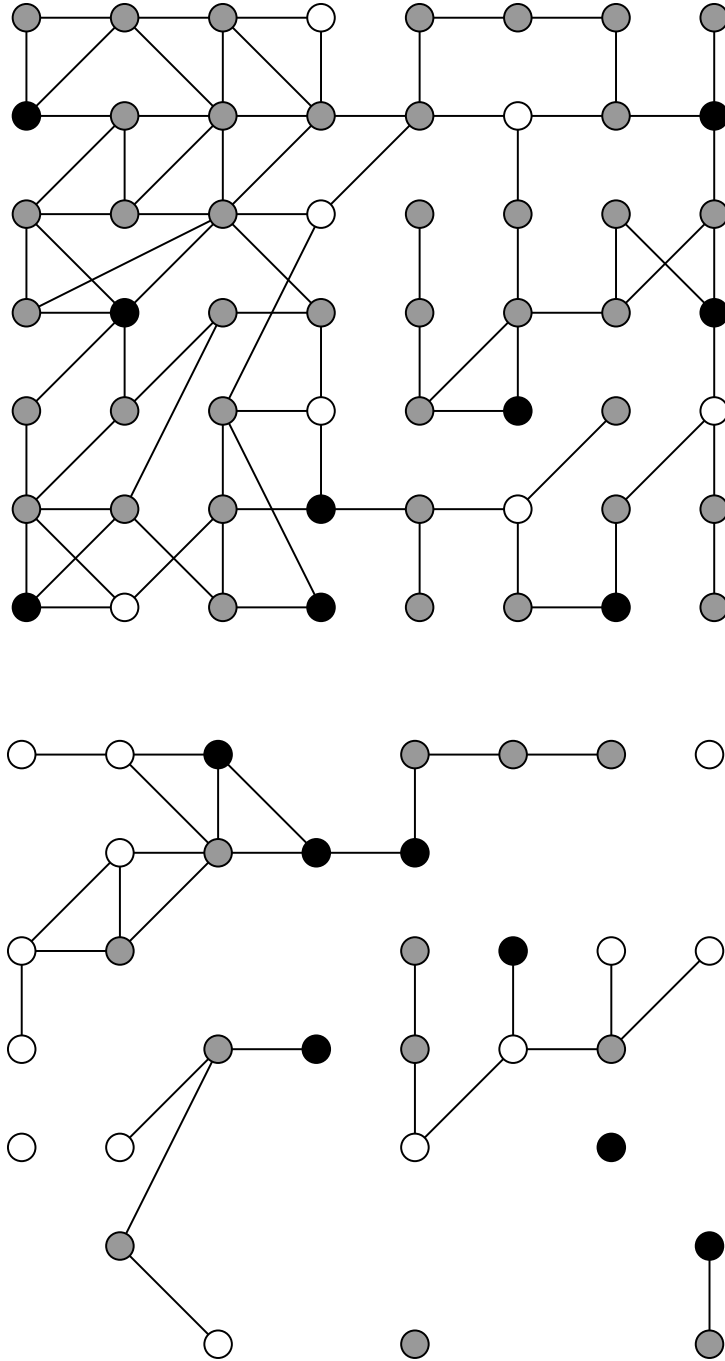
The description of a position consists of the graph on which the two players are playing, and a reservation function from the set of vertices to the set of colours {black, white, grey}.

**Example 3.48** Figure 3.11 shows an example of a COL position under the two representations. On top is the first representation as in the original definition of the game. On bottom is the second representation, that we use in the following. Both represent the same game. To go from the original representation to the second representation, we delete black vertices and colour their neighbours white, delete vertices that were originally white and colour their neighbours black, and delete vertices we gave both colours. We can see the second representation seems simpler, and that is why we use it.

**Example 3.49** Figure 3.12 gives an example of a Right move. Right chooses the grey vertex  $x$ . That vertex is removed from the game. The white vertex  $y$  also disappears. The grey vertex  $z$  becomes black. The black vertex  $t$  stays black. The rest of the graph does not change as no other vertices are neighbours of  $x$ .

We represent some graphs using words: each letter used in this representation corresponds to a subgraph with a specific vertex being incident with the edges connecting that subgraph to the subgraphs corresponding to the letters before and after this one. The specific vertices corresponding to the first letter and the last letter are not neighbours, unless the words has length 2. An  $o$  represents a grey vertex, a  $B$  a black vertex and a  $W$  a white vertex, the only vertex being the specific vertex. An  $x$  represents a path with two grey vertices, anyone of them being the specific vertex. All the graphs that can be represented by words using these letters are caterpillars with maximum degree 3. We also note  $C_n$  the cycle on  $n$  grey vertices.

**Example 3.50** Figure 3.13 shows a word and the unique graph that it encodes. You can see that for each  $x$ , there is a vertex whose degree remains 1.



**Figure 3.11:** A COL position in its two representations

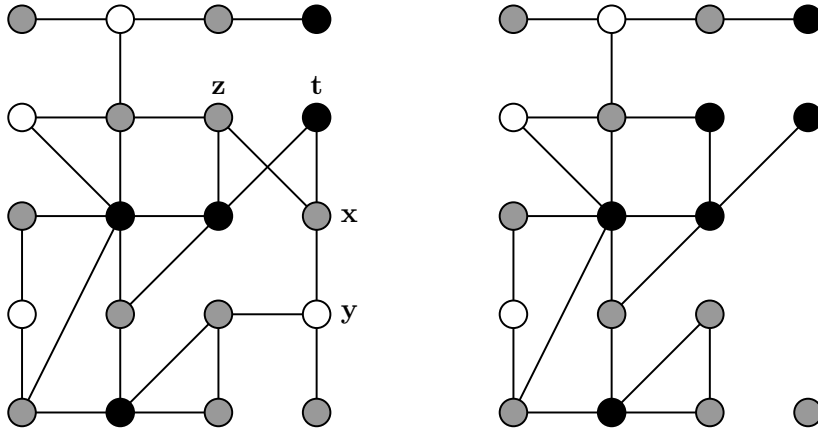


Figure 3.12: Playing a move in COL

xWooxxxoWoBxoWxooxWBoxBoxxo

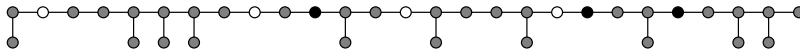


Figure 3.13: Representation of a caterpillar by a word

We now introduce a few notation that we use in the following. We note  $\ell_G(v)$  the label of a vertex  $v \in V(G)$ , that is  $B$  if the vertex is coloured black,  $W$  if it is coloured white and  $o$  if it is uncoloured. Modifying the label of a vertex is equivalent to modifying its colour. We say  $\ell_G(u) = -\ell_G(v)$  if both  $\ell_G(u)$  and  $\ell_G(v)$  are  $o$  or if one is  $B$  and the other is  $W$ . Given a COL position  $G$ , we note  $-G$  the COL position such that  $V(-G) = V(G)$ ,  $E(-G) = E(G)$  and  $\forall v \in G, \ell_{-G}(v) = -\ell_G(v)$ . The reader would have recognised that the game  $-G$  is the conjugate of the game  $G$ . Given two COL positions  $G_1, G_2$  and two vertices  $u_1 \in V(G_1), u_2 \in V(G_2)$  such that  $\ell_{G_1}(u_1) = \ell_{G_2}(u_2)$ , we note  $(G_1, u_1) \odot (G_2, u_2)$  the COL position defined by:

$$\begin{aligned} V((G_1, u_1) \odot (G_2, u_2)) &= V(G_1) \cup V(G_2) \setminus \{u_2\} \\ E((G_1, u_1) \odot (G_2, u_2)) &= E(G_1) \cup E(G_2[V(G_2) \setminus \{u_2\}]) \\ &\quad \cup \{(u_1, v) \mid (u_2, v) \in E(G_2)\} \\ \ell_{(G_1, u_1) \odot (G_2, u_2)}(v) &= \begin{cases} \ell_{G_1}(v) & \text{if } v \in V(G_1) \\ \ell_{G_2}(v) & \text{otherwise} \end{cases} \end{aligned}$$

Given a vertex  $u$  in a COL position  $G$ , we note by  $G_u^+$  (resp.  $G_u^-$ ) the COL position obtained from  $G$  by re-labelling  $B$  (resp.  $W$ ) the vertex  $u$ .

We note  $P_n^B$  (resp  $P_n^{BB}, P_n^{BW}, P_n^{WB}, P_n^{WW}$ ) the COL position  $(Bo^n, u)$  (resp  $(Bo^nB, u), (Bo^nW, u), (Wo^nB, u), (Wo^nW, u)$ ) where the specific vertex  $u$

is such that  $\ell_{P_n^B}(u) = B$  (resp  $\ell_{P_n^{BB}}(u) = B$ ,  $\ell_{P_n^{BW}}(u) = B$ ,  $\ell_{P_n^{WB}}(u) = W$ ,  $\ell_{P_n^{WW}}(u) = W$ ).

In this section, we recall some results stated in [4] and [10] and give their proofs, find the normal outcome of most caterpillars with no reserved vertex and the normal outcome of any cograph with no reserved vertex. We present some results that are already stated in [4] and [10] because most of them are stated without proof, and though we trust the authors of these books, we think it is interesting to have the proof written somewhere.

### 3.3.1 General results

First, we look at general graphs and give some tools that help the analysis.

The first theorem gives a winning strategy in specific situations: when a position is symmetric, with no vertex being its own image, the second player wins by always playing on the image of the vertex their opponent just played. This is close to the ‘Tweedledum-Tweedledee’ strategy, except that the position is not necessarily of the form  $G + (-G)$ .

**Theorem 3.51 (Berlekamp et al. [4], Conway [10])** *Let  $G$  be a COL position such that there exists a fix-point-free involution  $f$  of  $V(G)$  such that:*

1.  $\forall u, v \in V(G), (u, v) \in E(G) \Leftrightarrow (f(u), f(v)) \in E(G)$
2.  $\forall v \in V(G), l_G(v) = -l_G(f(v))$

*Then  $G \equiv^+ 0$ .*

**Proof.** We show it by induction on  $|V(G)|$ .

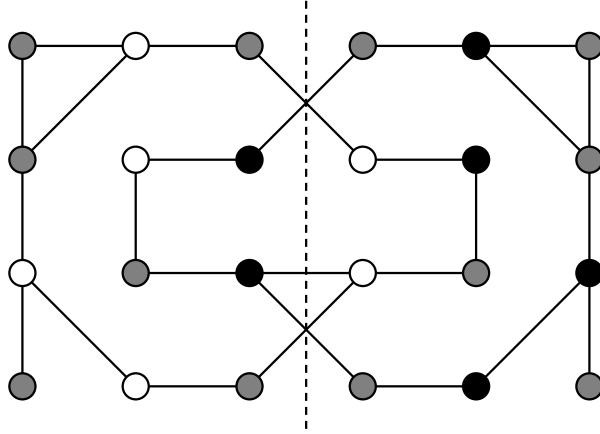
If  $|V(G)| = 0$ ,  $G = \emptyset = \{\cdot \mid \cdot\} = 0$ .

Assume now  $|V(G)| \geq 2$ . Let  $G^L$  be the graph after a move of Left on any vertex  $u$  from  $G$ . Let  $G'$  be the graph after a move of Right on the vertex  $f(u)$  from  $G^L$  which is possible since  $u \neq f(u)$  and  $l_G(u) = -l_G(f(u))$ .  $f|_{G'}$  is a fix-point-free involution of  $V(G')$  such that  $\forall v, w \in V(G'), (v, w) \in E(G') \Leftrightarrow (f|_{G'}(v), f|_{G'}(w)) \in E(G')$  and  $\forall v \in V(G'), l_{G'}(v) = \overline{l_{G'}(f|_{G'}(v))}$ , so  $G' \equiv^+ 0$  by induction and is a second player win. Hence Right has a winning strategy playing second.

A similar reasoning would show Left has a winning strategy playing second. Hence  $G \equiv^+ 0$ .  $\square$

**Example 3.52** Figure 3.14 shows an example of a COL position satisfying the conditions of Theorem 3.51. The image of each vertex is the reflective vertex through the dashed line.

The next theorem allows us to compare a position to the same position in which we would have removed some edges, all of them incident to a black vertex. This comparison seems natural as it seems to be an advantage when a vertex reserved for you has a low degree.



**Figure 3.14:** A symmetric COL  $\mathcal{P}$ -position

**Theorem 3.53** (Berlekamp et al. [4], Conway [10]) *Let  $G$  and  $G'$  be two COL positions such that:*

1.  $V(G) = V(G')$ ,
2.  $\forall u \in V(G), l_G(u) = l_{G'}(u)$ ,
3.  $E(G') \subseteq E(G)$ ,
4.  $\forall (u, v) \in E(G) \setminus E(G'), (l_G(u) = B \text{ or } l_G(v) = B)$ .

*Then  $G \leq^+ G'$ .*

**Proof.** We show by induction on  $|V(G)|$  that  $G' + (-G) \geq^+ 0$ , that is Left wins if Right starts.

If  $|V(G)| = 0$ ,  $G' + (-G) = \emptyset + \emptyset = 0 + 0 = 0$ .

Assume now  $|V(G)| \geq 2$ . Let  $f$  be the function which assigns a vertex of  $V(G')$  to its copy in  $V(-G)$  and vice versa. Let  $G^R$  be the graph after a move of Right on any vertex  $u$  from  $G' + (-G)$ . Let  $G_0$  be the graph after a move of Left on the vertex  $f(u)$  from  $G^R$ . Let  $G_1$  be the subgraph of  $G_0$  having its vertices corresponding to those of  $-G$  and  $G_2$  the subgraph of  $G_0$  having its vertices corresponding to those of  $G'$ . We have  $V(-G_1) = V(G_2)$ ,  $\forall u \in V(-G_1), l_{-G_1}(u) = l_{G_2}(u)$ ,  $E(G_2) \subseteq E(-G_1)$  and  $\forall (u, v) \in E(G_1) \setminus E(G_2), (l_{-G_1}(u) = B \text{ or } l_{-G_1}(v) = B)$ , so  $G_2 + G_1 \geq^+ 0$  by induction. So  $G_0 \geq^+ 0$  and Left wins  $G_0$  if Right starts, so she wins  $G^R$  if she starts. So  $G' + (-G) \geq^+ 0$ . Hence  $G \leq^+ G'$ .  $\square$

As we get a similar result if the removed edges are all incident to a white vertex, we get the following corollary.

**Corollary 3.54** (Berlekamp et al. [4], Conway [10]) *Let  $G$  and  $G'$  be two COL positions such that:*

1.  $V(G) = V(G')$
2.  $\forall u \in V(G), l_G(u) = l_{G'}(u)$
3.  $E(G') \subseteq E(G)$
4.  $\forall (u, v) \in E(G) \setminus E(G'), ((l_G(u) = B \text{ and } l_G(v) = W)) \text{ or vice versa}$

Then  $G \equiv^+ G'$ .

**Proof.** We have  $G \leq^+ G'$  and  $-G \leq^+ -G'$ , so  $G \equiv^+ G'$ .  $\square$

Actually, we even have  $G = G'$  in this case.

Adding a black vertex or reserving a vertex for Left seems to be an advantage for her. The next theorem shows that this intuition is correct.

**Theorem 3.55 (Berlekamp et al. [4], Conway [10])** *Let  $G$  be a COL position and  $u$  a grey vertex of  $G$ . Then:*

1.  $G_u^+ \geq^+ G \geq^+ G_u^-$
2.  $G_u^+ \geq^+ G \setminus \{u\} \geq^+ G_u^-$

**Proof.** We show by induction on  $|V(G)|$  that  $G_u^+ + (-G \setminus \{u\}) \geq^+ 0$ , that is Left wins if Right starts.

If  $|V(G)| = 0$ ,  $G_u^+ + (-G \setminus \{u\}) = \emptyset + \emptyset = 0$ .

Assume now  $|V(G)| \geq 2$ . We define  $f$  the function which assigns a vertex of  $V(G_u^+) \setminus \{u\}$  to its copy in  $V(-G \setminus \{u\})$  and vice versa. Let  $G^R$  be the graph after a move of Right on any vertex  $v$  from  $G_u^+ + (-G \setminus \{u\})$ . Let  $G_0$  be the graph after a move of Left on the vertex  $f(v)$  from  $G^R$ . Let  $G_1$  be the subgraph of  $G_0$  having its vertices corresponding to those of  $G_u^+$  and  $G_2$  the subgraph of  $G_0$  having its vertices corresponding to those of  $-G \setminus \{u\}$ . If  $(u, f(v)) \in E(G_u^+ + (-G \setminus \{u\}))$ , then  $G_1 = -G_2$ , so  $G_0 = G_1 + G_2 = 0$ . Otherwise,  $G_1 = G_{1u}^+$  and  $G_2 = -G_1 \setminus \{u\}$ , so  $G_0 = G_1 + G_2 \geq^+ 0$  by induction. Hence  $0 \leq^+ G_0$  and Left wins  $G_0$  if Right starts, so she wins  $G^R$  if she starts. So  $G_u^+ + (-G \setminus \{u\}) \geq^+ 0$ . Hence  $G_u^+ \geq^+ G \setminus \{u\}$ .

We show by induction on  $|V(G)|$  that  $G_u^+ + (-G) \geq^+ 0$ , that is Left wins it if Right starts.

If  $|V(G)| = 0$ ,  $G_u^+ + (-G) = \emptyset + \emptyset = 0$ .

Assume  $|V(G)| \geq 2$ . We define  $f$  the function which assigns a vertex of  $V(G_u^+)$  to its copy in  $V(-G)$  and vice versa. Let  $G^R$  be the graph after a move of Right on any vertex  $v$  from  $G_u^+ + (-G)$ . Let  $G_0$  be the graph after a move of Left on the vertex  $f(v)$  from  $G^R$ . Let  $G_1$  be the subgraph of  $G_0$  having its vertices corresponding to those of  $G_u^+$  and  $G_2$  the subgraph of  $G_0$  having its vertices corresponding to those of  $-G$ . If  $u = f(v)$  or  $(u, v) \in E(G_u^+ + (-G \setminus \{u\}))$ , then  $G_1 = -G_2$ , so  $G_0 = G_1 + G_2 = 0$ . If  $(u, f(v)) \in E(G_u^+ + (-G \setminus \{u\}))$ , then  $G_2 = G_{2u}^+$  and  $G_1 = G_2 \setminus \{u\}$ , so  $G_0 = G_1 + G_2 \geq^+ 0$ . Otherwise,  $G_1 = (-G_2)_u^+$ , so  $G_0 = G_1 + G_2 \geq^+ 0$  by

induction. Hence  $0 \leq^+ G_0$  and Left wins  $G_0$  if Right starts, so she wins  $G^R$  if she starts. So  $G_u^+ + (-G) \geq^+ 0$ . Hence  $G_u^+ \geq^+ G$ .

Finally,  $-(G_u^-) = (-G)_u^+$ , so  $-(G_u^-) \geq^+ -G$  and  $-(G_u^-) \geq^+ -G \setminus \{u\}$ . Hence  $G \geq^+ G_u^-$  and  $G \setminus \{u\} \geq^+ G_u^-$ .  $\square$

The next theorem says that any COL position is equivalent under normal play to a number or to the game  $*$  added to a number, which makes finding the outcome of a sum easier. In particular, it implies that the sum of two COL  $\mathcal{N}$ -positions is a  $\mathcal{P}$ -position. Also, if we find a move to  $z$  for both players, we know the value of the game is  $z + *$  without having the need to check other options. It also implies that if  $G$  is a COL position where  $G = -G$ , which is the case when all vertices are grey, then  $G = 0$  or  $G = *$ . See [4], vol.1, p.47-48 for the proof.

**Theorem 3.56 (Berlekamp et al. [4], Conway [10])** *For any COL position  $G$ , there exists a number  $z$  such that  $G = z$  or  $G = z + *$ .*

In a COL position, if there is a vertex for which the position has the same value when the colour of the vertex is switched to black and when the colour of the vertex is switched to white, it seems no player wants to play on that vertex, whether it is reserved or not. The intuition is correct, and the following theorem shows a result even stronger: even if you identify that vertex to any vertex of another position, keeping the first position as it was, with no other vertex adjacent to a vertex of the added position, no player wants to play on that vertex, whether it is reserved or not.

**Theorem 3.57 (Berlekamp et al. [4], Conway [10])**

1. Let  $G$  be a COL position and  $u$  a grey vertex of  $G$  such that  $G_u^+ \equiv^+ G_u^-$ ,  $G'$  any COL position and  $v$  a grey vertex of  $G'$ . Then  $(G_u^+, u) \odot (G_v^+, v) \equiv^+ (G, u) \odot (G', v) \equiv^+ (G \setminus \{u\}) + (G' \setminus \{v\}) \equiv^+ (G_u^-, u) \odot (G_v^-, v)$ .
2. Let  $G$  be a COL position and  $u$  a vertex of  $G$  such that  $G_u^+ \equiv^+ G \setminus \{u\}$ ,  $G'$  any COL position and  $v$  a vertex of  $G'$  sharing the colour of  $u$ . Then  $(G_u^+, u) \odot (G_v^+, v) \equiv^+ (G \setminus \{u\}) + (G' \setminus \{v\})$ .

**Proof.** 1. We have  $G_u^+ \equiv^+ G_u^-$ , so  $0 \equiv^+ G_u^+ + (-G_u^-) \equiv^+ G_u^+ + (-G)_u^+$ . Moreover,

$$\begin{aligned} 0 &\equiv^+ G \setminus \{u\} + (-G \setminus \{u\}) + G' \setminus \{v\} + (-G' \setminus \{v\}) \\ &\equiv^+ G \setminus \{u\} + G' \setminus \{v\} + (-G) \setminus \{u\} + (-G') \setminus \{v\} \\ &\leq^+ (G_u^+, u) \odot (G_v^+, v) + ((-G)_u^+, u) \odot ((-G')_v^+, v) \\ &\leq^+ G_u^+ + G' \setminus \{v\} + (-G)_u^+ + (-G') \setminus \{v\} \\ &\equiv^+ (G_u^+ + (-G)_u^+) + (G' \setminus \{v\} + (-G') \setminus \{v\}) \\ &\equiv^+ 0 \end{aligned}$$

Hence

$$\begin{aligned} 0 &\equiv^+ (G_u^+, u) \odot (G_v^+, v) + ((-G)_u^+, u) \odot ((-G')_v^+, v) \\ &\equiv^+ (G_u^+, u) \odot (G_v^+, v) + (-((G_u^-, u) \odot (G_v^-, v))) \end{aligned}$$

From Theorem 3.55, we get

$$\begin{aligned} (G_u^+, u) \odot (G_v'^+, v) &\equiv^+ (G, u) \odot (G', v) \\ &\equiv^+ (G \setminus \{u\}) + (G' \setminus \{v\}) \\ &\equiv^+ (G_u^-, u) \odot (G_v'^-, v) \end{aligned}$$

2. We have  $G_u^+ \equiv^+ G \setminus \{u\}$ , so  $0 \equiv^+ G_u^+ + (-G \setminus \{u\})$ .

$$\begin{aligned} 0 &\equiv^+ G \setminus \{u\} + G' \setminus \{u\} + (-G \setminus \{u\}) + (-G' \setminus \{u\}) \\ &\leq^+ (G_u^+, u) \odot (G_v'^+, v) + (-((G \setminus \{u\}) + (G' \setminus \{v\}))) \\ &\leq^+ G_u^+ + G' \setminus \{v\} + (-G \setminus \{u\}) + (-G' \setminus \{v\}) \\ &\equiv^+ 0 \end{aligned}$$

Hence

$$\begin{aligned} 0 &\equiv^+ (G_u^+, u) \odot (G_v'^+, v) + (-((G \setminus \{u\}) + (G' \setminus \{v\}))) \\ (G_u^+, u) \odot (G_v'^+, v) &\equiv^+ (G \setminus \{u\}) + (G' \setminus \{v\}) \end{aligned}$$

□

We immediately get the following corollary, that we use frequently in the following of the section.

**Corollary 3.58 (Berlekamp et al. [4], Conway [10])** *For any COL position  $G$ , and any vertex  $v$  of  $G$  such that  $\ell_G(v) = B$ , we have*

$$(G, v) \odot P_0^{BB} \equiv^+ (G \setminus \{v\}) + B.$$

**Proof.** We have  $B = \{\emptyset \mid \cdot\} = BB$ . □

### 3.3.2 Known results

We now focus on some classes of trees. Though we want to find the outcomes of COL positions where all vertices are grey, we need intermediate lemmas where some vertices are black or white.

We first prove that cycles and paths having only grey vertices all have value 0, apart from the isolated vertex which has value \*. We separate the proof with two lemmas, covering all possible maximal connected subpositions that may appear throughout such a game, as the disjunctive sum of numbers and \* is easy to determine, before Theorem 3.61 ends the proof.

The first lemma gives the values of all paths where each leaf is either black or white, and all internal nodes are grey.

**Lemma 3.59 (Berlekamp et al. [4], Conway [10])**

1.  $\forall n \geq 0, B \equiv^+ Bo^n B \equiv^+ 1$ .
2.  $\forall n \geq 0, Bo^n W \equiv^+ 0$ .



**Proof.** We show the results simultaneously by induction on  $n$ .

$$B = \{\emptyset \mid \cdot\} = \{0 \mid \cdot\} \equiv^+ 1. \quad BB = \{\emptyset \mid \cdot\} = \{0 \mid \cdot\} \equiv^+ 1.$$

$$BW = B + W \equiv^+ 0.$$

Let  $n \geq 1$  be an integer.

$$\begin{aligned} Bo^n B &= \{Wo^{n-1}B, Wo^{n-2}B, \bigcup_{i=0}^{n-3} (Bo^iW + Wo^{n-i-3}B) \\ &\quad \mid (B + Bo^{n-2}B), \bigcup_{i=0}^{n-3} (Bo^iB + Bo^{n-i-3}B)\} \\ &\equiv^+ \{0, 0, (0+0) \mid 2, (1+1)\} \text{ by induction} \\ &\equiv^+ 1. \end{aligned}$$

$$\begin{aligned} Bo^n W &= \{Wo^{n-1}W, Wo^{n-2}W, (Bo^{n-2}W + W), \bigcup_{i=0}^{n-3} (Bo^iW + Wo^{n-i-3}W) \\ &\quad \mid Bo^{n-1}B, Bo^{n-2}B, (B + Bo^{n-2}W), \bigcup_{i=0}^{n-3} (Bo^iB + Bo^{n-i-3}W)\} \\ &\equiv^+ \{-1, -1, (0+(-1)), (0+(-1)) \mid 1, 1, (1+0), (1+0)\} \\ &\quad \text{by induction} \\ &\equiv^+ 0. \end{aligned}$$

□

The following lemma gives the values of all paths where exactly one leaf is either black or white, and all other vertices, including the other leaf, are grey.

**Lemma 3.60 (Berlekamp et al. [4], Conway [10])**  $\forall n \geq 1, Bo^n \equiv^+ \frac{1}{2}$ .

**Proof.** We show the result by induction on  $n$ .

$$Bo = \{W, \emptyset \mid B\} = \{-1, 0 \mid 1\} \equiv^+ \frac{1}{2}.$$

$$Boo = \{Wo, W, BW \mid (B+B), BB\} \equiv^+ \{-\frac{1}{2}, -1, 0 \mid (1+1), 1\} \equiv^+ \frac{1}{2}.$$

Let  $n \geq 3$  be an integer.

$$\begin{aligned} Bo^n &= \{Wo^{n-1}, Wo^{n-2}, \bigcup_{i=1}^{n-4} (Bo^iW + Wo^{n-i-3}), (Bo^{n-3}W + W), Bo^{n-2}W \\ &\quad \mid (B + Bo^{n-2}), \bigcup_{i=1}^{n-4} (Bo^iB + Bo^{n-i-3}), (Bo^{n-3}B + B), Bo^{n-2}B\} \\ &\equiv^+ \{-\frac{1}{2}, -\frac{1}{2}, (0 - \frac{1}{2}), (0+(-1)), 0 \mid (1 + \frac{1}{2}), (1 + \frac{1}{2}), (1+1), 1\} \\ &\quad \text{by induction} \\ &\equiv^+ \frac{1}{2}. \end{aligned}$$

□

We are now able to state the result giving the value of any grey path and any cycle, as mentioned above.

**Theorem 3.61 (Berlekamp et al. [4], Conway [10])**

1.  $\forall n \geq 2$ ,  $o^n \equiv^+ 0$ , and  $o = *$ .
2.  $\forall n \geq 3$ ,  $C_n \equiv^+ 0$ .

**Proof.**  $o = \{\emptyset \mid \emptyset\} = \{0 \mid 0\} = *$ .  $oo = \{W \mid B\} = \{-1 \mid 1\} \equiv^+ 0$ .  
 $ooo = \{Wo, (W+W) \mid Bo, (B+B)\} \equiv^+ \{-\frac{1}{2}, -2 \mid \frac{1}{2}, 2\} \equiv^+ 0$ .  
 $oooo = \{Woo, (W+Wo) \mid Boo, (B+Bo)\} \equiv^+ \{-\frac{1}{2}, -\frac{3}{2} \mid \frac{1}{2}, \frac{3}{2}\} \equiv^+ 0$ .  
Let  $n \geq 5$  be an integer.

$$\begin{aligned} o^n &= \{Wo^{n-2}, (W+Wo^{n-3}), \bigcup_{i=1}^{\frac{n-3}{2}} (o^i W + Wo^{n-i-3}) \\ &\quad \mid Bo^{n-2}, (B+Bo^{n-3}) \bigcup_{i=1}^{\frac{n-3}{2}} (o^i B + Bo^{n-i-3})\} \\ &\equiv^+ \{-\frac{1}{2}, -\frac{3}{2}, -1 \mid \frac{1}{2}, \frac{3}{2}, 1\} \\ &\equiv^+ \{0\}. \end{aligned}$$

$$C_n = \{Wo^{n-3}W \mid Bo^{n-3}B\} \equiv^+ \{-1 \mid 1\} \equiv^+ 0. \quad \square$$

The next theorem gives a useful tool on how to shorten long paths leading to a degree 1 vertex in a general position, while keeping the value unchanged. We prove that result using the original definition of comparison and equivalence between games, as defined in [10]:

$$G \geq^+ H \Leftrightarrow ((\forall G^R \in G^R, G^R \not\leq H) \wedge (\forall H^L \in H^L, G \not\leq H^L)).$$

**Theorem 3.62 (Berlekamp et al. [4], Conway [10])**

1.  $\forall G, u \in V(G)$  such that  $\ell_G(u) = B, n \geq 1$ ,  
 $(G, u) \odot P_{n+2}^B \equiv^+ (G, u) \odot P_n^{BB} - \frac{1}{2} \equiv^+ (G, u) \odot P_n^{BW} + \frac{1}{2}$ .
2.  $\forall G, u \in V(G)$  such that  $\ell_G(u) = B, n \geq 1$ ,  
 $(G, u) \odot P_n^{BB} \equiv^+ (G, u) \odot P_1^{BB}$ .
3.  $\forall G, u \in V(G)$  such that  $\ell_G(u) = B, n \geq 1$ ,  
 $(G, u) \odot P_n^{BW} \equiv^+ (G, u) \odot P_1^{BW}$ .
4.  $\forall G, u \in V(G)$  such that  $\ell_G(u) = B, n \geq 3$ ,  $(G, u) \odot P_n^B \equiv^+ (G, u) \odot P_3^B$ .

**Proof.** For most of the proof, we list the set of options of both games. Options on the same line are equal, as explained on the third column of that line. Having Left options of two games equal is enough to conclude none of these options is greater than or equal to any of these two games (that follows from  $G \geq^+ G$  for any game  $G$ ).

We show 1. by induction on the birthday of  $G$ .

If  $G = \emptyset$ , then it follows immediately from Lemma 3.59 and 3.60. Assume

$G$  is a non-empty position. Let  $G_3^L$  be the position after a move of Left on  $u$  from  $G$ ,  $G_2^L$  the position after a move of Left on a neighbour of  $u$  from  $G$ ,  $G_1^L$  the position after a move of Left on any other vertex from  $G$ , and  $G^R$  the position after a move of Right on any vertex from  $G$ .

We get

Left options of $(G, u) \odot P_n^{BB}$	Left options of $(G, u) \odot P_n^{BW} + 1$	
$(G_1^L, u) \odot P_n^{BB}$	$(G_1^L, u) \odot P_n^{BW} + 1$	by induction
$G_2^L + o^n B$	$G_2^L + o^n W + 1$	by Lemma 3.60
$G_3^L + W o^n - 1 B$	$G_3^L + W o^n - 1 W + 1$	by Lemma 3.59
$(G \setminus \{u\}) + W o^{n-2} B$	$(G \setminus \{u\}) + W o^{n-2} W + 1$	by Lemma 3.59
$((G, u) \odot P_i^{BW}) + W o^{n-i-3} B$	$((G, u) \odot P_i^{BW}) + W o^{n-i-3} W + 1$	$\forall i \in \llbracket 0; n-3 \rrbracket$ by Lemma 3.59
$(\bar{G}, u) \odot P_{n-2}^{BW}$	$(\bar{G}, u) \odot P_{n-2}^{BW} + W + 1$	
$(G, u) \odot P_{n-1}^{BW}$		
	$(G, u) \odot P_n^{BW}$	

We can see almost all of them are one-to-one equal. We assure no Left option of  $(G, u) \odot P_n^{BB}$  is greater than or equal to  $(G, u) \odot P_n^{BW} + 1$  and no Left option of  $(G, u) \odot P_n^{BW} + 1$  is greater than or equal to  $(G, u) \odot P_n^{BB}$  for the others as follows:

$$\begin{aligned}
(G, u) \odot P_{n-1}^{BW} &\leq^+ ((G \setminus \{u\}) + B o^{n-1} W) \\
&\equiv^+ ((G \setminus \{u\}) + W o^{n-1} W + 1) \\
&\not\geq^+ (G, u) \odot P_n^{BW} + 1 \\
(G, u) \odot P_n^{BW} &\leq^+ ((G \setminus \{u\}) + B o^n W) \\
&\equiv^+ ((G \setminus \{u\}) + W o^{n-1} B) \\
&\not\geq^+ (G, u) \odot P_n^{BB}
\end{aligned}$$

We also get

Right options of $(G, u) \odot P_n^{BB}$	Right options of $(G, u) \odot P_n^{BW} + 1$	
$(G^R, u) \odot P_n^{BB}$	$(G^R, u) \odot P_n^{BW} + 1$	by induction
$G + B o^{n-2} B$	$G + B o^{n-2} W + 1$	by Lemma 3.59
$((G, u) \odot P_i^{BB}) + B o^{n-i-3} B$	$((G, u) \odot P_i^{BB}) + B o^{n-i-3} W + 1$	$\forall i \in \llbracket 0; n-3 \rrbracket$ by Lemma 3.59
$((G, u) \odot P_{n-2}^{BB}) + B$	$((G, u) \odot P_{n-2}^{BB}) + 1$	
	$((G, u) \odot P_{n-1}^{BB}) + 1$	

We can see almost all of them are one-to-one equal. We assure no Right option of  $(G, u) \odot P_n^{BB}$  is less than or equal to  $(G, u) \odot P_n^{BW} + 1$  and no Right option of  $(G, u) \odot P_n^{BW} + 1$  is less than or equal to  $(G, u) \odot P_n^{BB}$  for

the other as follows:

$$\begin{aligned} ((G, u) \odot P_{n-1}^{BB}) + 1 &\geq^+ ((G \setminus \{u\}) + o^{n-1}B + 1) \\ &>^+ ((G \setminus \{u\}) + Bo^n B) \\ &\geq^+ (G, u) \odot P_n^{BB} \end{aligned}$$

Hence we have  $(G, u) \odot P_n^{BB} \equiv^+ (G, u) \odot P_n^{BW} + 1$ .

We get

Left options of $(G, u) \odot P_n^{BB} - \frac{1}{2}$	Left options of $(G, u) \odot P_{n+2}^B$	
$(G_1^L, u) \odot P_n^{BB} - \frac{1}{2}$	$(G_1^L, u) \odot P_{n+2}^B$	by induction
$G_2^L + o^n B - \frac{1}{2}$	$G_2^L + o^{n+2}$	by Lemma 3.60
$G_3^L + Wo^n - 1B - \frac{1}{2}$	$G_3^L + Wo^{n+1}$	by Lemma 3.60
$(G \setminus \{u\}) + Wo^{n-2}B - \frac{1}{2}$	$(G \setminus \{u\}) + Wo^n$	by Lemma 3.59 and 3.60
$((G, u) \odot P_i^{BW}) + Wo^{n-i-3}B - \frac{1}{2}$	$((G, u) \odot P_i^{BW}) + Wo^{n-i-1}$	$\forall i \in \llbracket 0; n-3 \rrbracket$ by Lemma 3.59 and 3.60
$(G, u) \odot P_{n-2}^{BW} - \frac{1}{2}$	$(G, u) \odot P_{n-2}^{BW} + Wo$	by Lemma 3.60
$(G, u) \odot P_{n-1}^{BW} - \frac{1}{2}$	$(G, u) \odot P_{n-1}^{BW} + W$	
$(G, u) \odot P_n^{BB} - 1$	$(G, u) \odot P_n^{BW}$	

We can see almost all of them are one-to-one equal. We assure no Left option of  $(G, u) \odot P_n^{BB} - \frac{1}{2}$  is greater than or equal to  $(G, u) \odot P_{n+2}^B$  and no Left option of  $(G, u) \odot P_{n+2}^B$  is greater than or equal to  $(G, u) \odot P_n^{BB} - \frac{1}{2}$  for the others as follows:

$$\begin{aligned} (G, u) \odot P_{n-1}^{BW} + W &<^+ (G, u) \odot P_{n-1}^{BW} - \frac{1}{2} \\ &\not\geq^+ (G, u) \odot P_n^{BB} - \frac{1}{2} \\ (G, u) \odot P_{n-1}^{BW} - \frac{1}{2} &\leq^+ (G \setminus \{u\}) + Bo^{n-1}W - \frac{1}{2} \\ &\equiv^+ (G \setminus \{u\}) + Wo^n \\ &\not\geq^+ (G, u) \odot P_{n+2}^B \end{aligned}$$

We also get

Right options of $(G, u) \odot P_n^{BB} - \frac{1}{2}$	Right options of $(G, u) \odot P_{n+2}^B$	
$(G^R, u) \odot P_n^{BB} - \frac{1}{2}$	$(G^R, u) \odot P_{n+2}^B$	by induction
$G + Bo^{n-2}B - \frac{1}{2}$	$G + Bo^n$	by Lemma 3.59 and 3.60
$((G, u) \odot P_i^{BB}) + Bo^{n-i-3}B - \frac{1}{2}$	$((G, u) \odot P_i^{BB}) + Bo^{n-i-1}$	$\forall i \in \llbracket 0; n-3 \rrbracket$ by Lemma 3.59 and 3.60
$((G, u) \odot P_{n-2}^{BB}) + B - \frac{1}{2}$	$((G, u) \odot P_{n-2}^{BB}) + Bo$	by Lemma 3.59 and 3.60
$(\bar{G}, u) \odot P_n^{BB} + 0$	$(\bar{G}, u) \odot P_n^{BB}$	

We can see almost all of them are one-to-one equal. We assure no Right option of  $(G, u) \odot P_n^{BB} - \frac{1}{2}$  is less than or equal to  $(G, u) \odot P_{n+2}^B$  and no Right option of  $(G, u) \odot P_{n+2}^B$  is less than or equal to  $(G, u) \odot P_n^{BB} - \frac{1}{2}$  for the other as follows:

$$\begin{aligned}
((G, u) \odot P_{n-1}^{BB}) + B &\geq^+ (G \setminus \{u\}) + o^{n-1}B + B \\
&>^+ (G \setminus \{u\}) + Bo^nB - \frac{1}{2} \\
&\geq^+ (G, u) \odot P_n^{BB} - \frac{1}{2}
\end{aligned}$$

Hence we have  $(G, u) \odot P_n^{BB} \equiv^+ (G, u) \odot P_{n+2}^B$ .

We show 2. by induction on the birthday of  $G$  and on  $n$ .

If  $G = \emptyset$ , then it follows immediately from Lemma 3.59. If  $n = 1$ , there is nothing to show.

Assume  $G$  is a non-empty graph and  $n \geq 2$ . Let  $G_3^L$  be the graph after a move of Left on  $u$  from  $G$ ,  $G_2^L$  the graph after a move of Left on a neighbour of  $u$  from  $G$ ,  $G_1^L$  the graph after a move of Left on any other vertex from  $G$ , and  $G^R$  the graph after a move of Right on any vertex from  $G$ .

We get

Left options of $(G, u) \odot P_n^{BB}$	Left options of $(G, u) \odot P_1^B$	
$(G_1^L, u) \odot P_n^{BB}$	$(G_1^L, u) \odot P_1^{BB}$	by induction
$G_2^L + o^nB$	$G_2^L + oB$	by Lemma 3.60
$G_3^L + Wo^n - 1B$	$G_3^L + WB$	by Lemma 3.59
$(G \setminus \{u\}) + Wo^{n-2}B$	$(G \setminus \{u\})$	by Lemma 3.60
$((G, u) \odot P_0^{BW}) + Wo^{n-3}B$	$((G, u) \odot P_0^{BW})$	by Lemma 3.59
$((G, u) \odot P_i^{BW}) + Wo^{n-i-3}B$		$\forall i \in \llbracket 0; n-3 \rrbracket$
$(\bar{G}, u) \odot P_{n-2}^{BW}$		
$(\bar{G}, u) \odot P_{n-1}^{BW}$		

We can see almost all of them are one-to-one equal. We assure no Left option of  $(G, u) \odot P_n^{BB}$  is greater than or equal to  $(G, u) \odot P_1^B$  and no Left option of  $(G, u) \odot P_1^B$  is greater than or equal to  $(G, u) \odot P_n^{BB}$  for the others as follows:

$$\begin{aligned}
((G, u) \odot P_i^{BW}) + Wo^{n-i-3}B &\leq^+ (G \setminus \{u\}) + Bo^iW + Wo^{n-i-3}B \\
&\equiv^+ G \setminus \{u\} \\
&\not\leq^+ (G, u) \odot P_1^B \\
(G, u) \odot P_{n-2}^{BW} &\leq^+ (G \setminus \{u\}) + Bo^{n-2}W \\
&\equiv^+ G \setminus \{u\} \\
&\not\leq^+ (G, u) \odot P_1^B \\
(G, u) \odot P_{n-1}^{BW} &\leq^+ (G \setminus \{u\}) + Bo^{n-1}W \\
&\equiv^+ G \setminus \{u\} \\
&\not\leq^+ (G, u) \odot P_1^B
\end{aligned}$$

We also get

Right options of $(G, u) \odot P_n^{BB}$	Right options of $(G, u) \odot P_1^{BB}$	
$(G^R, u) \odot P_n^{BB}$	$(G^R, u) \odot P_1^{BB}$	by induction
$G + Bo^{n-2}B$	$G + B$	by Lemma 3.59
$((G, u) \odot P_0^{BB}) + Bo^{n-3}B$		
$((G, u) \odot P_i^{BB}) + Bo^{n-i-3}B$		$\forall i \in \llbracket 1; n-3 \rrbracket$
$((G, u) \odot P_{n-2}^{BB}) + B$		

We can see almost all of them are one-to-one equal. We assure no Right option of  $(G, u) \odot P_n^{BB}$  is greater than or equal to  $(G, u) \odot P_1^B$  and no Right option of  $(G, u) \odot P_1^B$  is greater than or equal to  $(G, u) \odot P_n^{BB}$  for the others as follows:

$$\begin{aligned}
((G, u) \odot P_0^{BB}) + Bo^{n-3}B &\equiv^+ ((G \setminus \{u\}) + B + B) \\
&\geq^+ ((G, u) \odot P_1^{BB} + B) \\
&\not\leq^+ (G, u) \odot P_1^B \\
((G, u) \odot P_i^{BB}) + Bo^{n-i-3}B &\equiv^+ ((G, u) \odot P_1^{BB} + B) \\
&\not\leq^+ (G, u) \odot P_1^B \\
((G, u) \odot P_{n-2}^{BB}) + B &\equiv^+ ((G, u) \odot P_1^{BB} + B) \\
&\not\leq^+ (G, u) \odot P_1^B
\end{aligned}$$

Hence we have  $(G, u) \odot P_n^{BB} \equiv^+ (G, u) \odot P_1^{BB}$ .

3. and 4. follow from 1. and 2.

□

We now get back to smaller sets of positions, leading to an algorithm to find the outcome of any grey tree with at most one vertex having degree at least 3, that is Theorem 3.77.

We start with two simple positions for which we give the value.

**Lemma 3.63 (Berlekamp et al. [4], Conway [10])**

1.  $oBo \equiv^+ 0$ .
2.  $ooBoo \equiv^+ 0$ .

**Proof.**  $oBo = \{o, (W + W) \mid Bo\} = \{*, -1 + (-1)\frac{1}{2}\} \equiv^+ 0$ .

$$\begin{aligned} ooBoo &= \{WBoo, (W + oo), (oW + Wo) \mid BBoo, (B + Boo)\} \\ &\equiv^+ \left\{-\frac{1}{2}, -1 + 0, -\frac{1}{2} - \frac{1}{2} \mid 1, 1 + \frac{1}{2}\right\} \quad \square \\ &\equiv^+ 0 \end{aligned}$$

These two positions are now candidates for applying Theorem 3.57: considering the middle vertex as  $u$ , we now have  $ooo_u^+ = 0 = -ooo_u^+ = ooo_u^-$  and  $ooooo_u^+ = 0 = -ooooo_u^+ = ooooo_u^-$ .

A similar result on arbitrarily long path would help too, and that is Lemma 3.66. To get there, we find the values of any maximal connected subpositions of positions we can reach from the original positions, which are given in the two following lemmas, following the same pattern as for Lemmas 3.59, 3.60 and Theorem 3.61.

First, we see the values of paths whose leaves are reserved, having exactly one extra reserved vertex. If that extra reserved vertex was adjacent to a leaf reserved for the same player, we could use Corollary 3.58 and then conclude with Lemma 3.60, to get a value which is actually different from the general pattern. Hence, we only consider the other cases.

**Lemma 3.64**

1.  $\forall n \geq 1, m \geq 1, Bo^n Bo^m B \equiv^+ 1$ .
2.  $\forall n \geq 0, m \geq 0, Wo^n Bo^m W \equiv^+ -1$ .
3.  $\forall n \geq 0, m \geq 1, Wo^n Bo^m B \equiv^+ 0$ .

**Proof.**

$$\begin{aligned} 1. \quad BoBoB &= \{WBoB, oB, (BW + WB) \mid (B + BoB)\} \\ &\equiv^+ \left\{0, \frac{1}{2}, (0 + 0) \mid (1 + 1)\right\} \\ &\equiv^+ 1 \end{aligned}$$

When  $n \geq 2$  or  $m \geq 2$ , it follows from Theorem 3.62.

2.

$$WBW = (W + B + W) = -1 + 1 + (-1) \equiv^+ -1.$$

$$WBoW = (W + BoW) \equiv^+ -1 + 0 = -1.$$

$$\begin{aligned} WoBoW &= \{(W + oW), (WW + WW) \mid BBoW, BoW\} \\ &\equiv^+ \left\{-1 - \frac{1}{2}, -1 + (-1) \mid \frac{1}{2}, 0\right\} \\ &\equiv^+ -1 \end{aligned}$$

When  $n \geq 2$  or  $m \geq 2$ , it follows from Theorem 3.62.

3.

$$\begin{aligned} WBoB &= (W + BoB) \equiv^+ -1 + 1 \equiv^+ 0. \\ WoBoB &= \{(W + oB), (WW + WB), Wo, WoBW \\ &\quad | BBoB, BoB, (WoB + B)\} \\ &\equiv^+ \{-1 + \frac{1}{2}, -1 + 0, -\frac{1}{2}, -1 \mid \frac{3}{2}, 1, 0 + 1\} \\ &\equiv^+ 0 \end{aligned}$$

When  $n \geq 2$  or  $m \geq 2$ , it follows from Theorem 3.62.  $\square$

We now see the values of paths where exactly one leaf is reserved, as well as exactly one extra vertex. Again, if that extra reserved vertex was adjacent to a leaf reserved for the same player, we could use Corollary 3.58 and conclude with Lemma 3.60, to get a value which is actually different from the general pattern. Hence, we again only consider other cases.

**Lemma 3.65**

1.  $\forall n \geq 1, m \geq 3, Bo^n Bo^m = \frac{1}{2}$ .
2.  $\forall n \geq 0, m \geq 3, Wo^n Bo^m = -\frac{1}{2}$ .

**Proof.**  $Bo^n Bo^m = (Bo^n BoW + Bo) \equiv^+ 0 + \frac{1}{2} = \frac{1}{2}$ .  
 $Wo^n Bo^m = (Wo^n BoW + Bo) \equiv^+ -1 + \frac{1}{2} \equiv^+ -\frac{1}{2}$ .  $\square$

Finally, we get the pattern on arbitrary long paths, where reserving exactly one vertex for a player does not give them an advantage, provided there are at least three vertices on each side of this vertex.

**Lemma 3.66 (Berlekamp et al. [4], Conway [10])**

$$\forall n \geq 3, m \geq 3, o^n Bo^m \equiv^+ 0.$$

**Proof.**

$$o^n Bo^m \equiv^+ (o^n BoW + Bo) \equiv^+ (WoBoW + Bo + Bo) \equiv^+ -1 + \frac{1}{2} + \frac{1}{2} \equiv^+ 0$$

by Theorem 3.62.  $\square$

We now find the outcome of the set of positions we cannot solve using only Lemmas 3.63 and 3.66 before applying Theorem 3.57, that are stated in Theorem 3.75: positions of the form  $o^n xoo$  with  $n$  at least 3. As before, we analyse the values of all maximal connected subpositions that players can reach from the initial position, which we are able to sum, but as there are more kinds of these positions, we need more intermediate lemmas.

First, we look at positions where a player would have played on the non-special vertex of  $x$ , and a player, not necessarily the other player, would have played on the farther leaf from the special vertex of  $x$ .

**Lemma 3.67**

1.  $\forall n \geq 0, Bo^n Boo \equiv^+ 1$ .



2.  $\forall n \geq 1, Wo^n Boo \equiv^+ 0$ .

**Proof.**  $BBoo \equiv^+ B + oo \equiv^+ 1$ .

$$\begin{aligned} BoBoo &= \{WBoo, oo, (B + Wo), (Bo + W), BoBW \\ &\quad | (B + Boo), (BoB + B), BoBB\} \\ &\equiv^+ \{-\frac{1}{2}, 1 - \frac{1}{2}, \frac{1}{2} + (-1), 0 | 1 + \frac{1}{2}, 1 + 1, \frac{3}{2}\} \\ &\equiv^+ 1 \end{aligned}$$

$$\begin{aligned} WoBoo &= \{(W + oo), (WW + Wo), (Wo + W), WoBW \\ &\quad | BBoo, Boo, (WoB + B), WoBB\} \\ &\equiv^+ \{-1 + 0, -1 - \frac{1}{2}, -\frac{1}{2} + (-1), -1 | 1, \frac{1}{2}, 0 + 1, \frac{1}{2}\} \\ &\equiv^+ 0 \end{aligned}$$

When  $n \geq 2$ , it follows from Theorem 3.62.  $\square$

We now find the value of a game where a player would have played on the non-special vertex of  $x$ , using the result we just got from Lemma 3.67.

**Lemma 3.68**  $\forall n \geq 3, o^n Boo \equiv^+ \frac{1}{2}$ .

**Proof.**  $o^n Boo \equiv^+ (WoBoo + Bo) \equiv^+ 0 + \frac{1}{2} = \frac{1}{2}$  by Theorem 3.62.  $\square$

We now consider paths where exactly two vertices are reserved, one being a leaf and the other being the neighbour of the other leaf. If those two vertices were neighbours, we could either use Corollary 3.58 and conclude with Theorem 3.61 or use Corollary 3.54 and conclude with Lemma 3.60, both giving values different from the general pattern. Hence, again, we only consider other cases.

**Lemma 3.69**

1.  $\forall n \geq 1, Bo^n Bo \equiv^+ \frac{3}{4}$ .
2.  $\forall n \geq 1, Wo^n Bo \equiv^+ -\frac{1}{4}$ .

**Proof.**

$$\begin{aligned} BoBo &= \{WBoo, o, (BW + W), Bo | (B + Bo), BoB\} \\ &\equiv^+ \{-\frac{1}{2}, *, 0 + (-1), \frac{1}{2} | 1 + \frac{1}{2}, 1\} \\ &\equiv^+ \frac{3}{4} \end{aligned}$$

$$\begin{aligned} WoBo &= \{(W + o), (WW + W), Wo | BBo, Bo, WoB\} \\ &\equiv^+ \{-1 + *, -1 + (-1), -\frac{1}{2} | 1*, \frac{1}{2}, 0\} \\ &\equiv^+ -\frac{1}{4} \end{aligned}$$

When  $n \geq 2$ , it follows from Theorem 3.62.  $\square$

We now use Lemma 3.69 to find the value of a path where exactly one vertex is reserved, provided one of its neighbours is a leaf and there are at least two vertices in the other direction, the cases where there is one or none having been solved earlier and yielding different values.

**Lemma 3.70**  $\forall n \geq 2, oBo^n \equiv^+ \frac{1}{4}$ .

**Proof.**

$$\begin{aligned} oBoo &= \{oo, (W + Wo), (o + W), oBW \mid Boo, (oB + B), oBB\} \\ &\equiv^+ \{0, -1 - \frac{1}{2}, * + (-1), -\frac{1}{2} \mid \frac{1}{2}, \frac{1}{2} + 1, 1*\} \\ &\equiv^+ \frac{1}{4} \end{aligned}$$

Let  $n \geq 3$  be an integer.

$$oBo^n \equiv^+ (oBoW + Bo) \equiv^+ -\frac{1}{4} + \frac{1}{2} \equiv^+ \frac{1}{4} \text{ by Theorem 3.62.} \quad \square$$

The next lemma gives the value of two small positions:  $BxB$  and  $BxW$ , as they do not follow the rule we state in Lemma 3.72.

**Lemma 3.71**

1.  $BxB \equiv^+ \frac{3}{2}$ .
2.  $BxW \equiv^+ *$ .

**Proof.**

$$\begin{aligned} BxB &= \{oWB, W, BWB \mid (B + B + B), BBB\} \\ &\equiv^+ \{-1, \frac{1}{2}, 1 \mid 2, 3\} \\ &\equiv^+ \frac{3}{2} \end{aligned}$$

$$\begin{aligned} BxW &= \{oWW, (W + W), BWW \mid oBB, (B + B), BBW\} \\ &\equiv^+ \{-2, -1*, 0 \mid 0, 1*, 2\} \\ &\equiv^+ * \end{aligned}$$

$\square$

We can use these results to find the value of the game after the players have played from  $o^n xoo$  on the two leaves not in the  $x$ , where  $n$  is at least 3.

**Lemma 3.72**

1.  $\forall n \geq 1, Bo^n xB \equiv^+ \frac{5}{4}$ .
2.  $\forall n \geq 1, Bo^n xW \equiv^+ -\frac{1}{4}$ .

**Proof.** We show the results simultaneously by induction on  $n$ .

$$\begin{aligned}
Bo^nxB &= \{Wo^{n-1}xB, Wo^{n-2}xB, \bigcup_{i=0}^{n-3} (Bo^iW + Wo^{n-i-3}xB), \\
&\quad (Bo^{n-2}W + oWB), (Bo^{n-1}W + W), Bo^nWB, Bo^nWo \\
&\quad | (B + Bo^{n-2}xB), \bigcup_{i=0}^{n-3} (Bo^iB + Bo^{n-i-3}xB), \\
&\quad (Bo^{n-2}B + oBB), (Bo^{n-1}B + B + B), Bo^nBB\} \\
&\equiv^+ \{-1, *, \frac{1}{4}, \frac{1}{2}, 1 \mid \frac{3}{2}, 2*, \frac{9}{4}, \frac{5}{2}, 3\} \text{ by induction} \\
&\equiv^+ \frac{5}{4}.
\end{aligned}$$

$$\begin{aligned}
Bo^nxB &= \{Wo^{n-1}xW, Wo^{n-2}xW, \bigcup_{i=0}^{n-3} (Bo^iW + Wo^{n-i-3}xW), \\
&\quad (Bo^{n-2}W + oWW), (Bo^{n-1}W + W + W), Bo^nWW \\
&\quad | (B + Bo^{n-2}xW), \bigcup_{i=0}^{n-3} (Bo^iB + Bo^{n-i-3}xW), \\
&\quad (Bo^{n-2}B + oBW), (Bo^{n-1}B + B), Bo^nBW, Bo^nBo\} \\
&\equiv^+ \{-2, -\frac{3}{2}, -\frac{5}{4}, -1*, -\frac{1}{2} \mid 0, \frac{1}{2}, \frac{3}{4}, 1*, 2\} \text{ by induction} \\
&\equiv^+ -\frac{1}{4}.
\end{aligned}$$

□

Now we give the value of the game after they have only played on one of these two leaves, starting with the one closer to the vertices represented by the  $x$ .

**Lemma 3.73**  $\forall n \geq 2, o^nxB \equiv^+ \frac{3}{4}$ .

**Proof.**

$$\begin{aligned}
o^nxB &= \{Wo^{n-2}xB, \bigcup_{i=0}^{n-3} (o^iW + Wo^{n-i-3}xB), (o^{n-2}W + oWB), \\
&\quad (o^{n-1}W + W), o^nWB, o^nWo \\
&\quad | Bo^{n-2}xB, \bigcup_{i=0}^{n-3} (o^iB + Bo^{n-i-3}xB), (o^{n-2}B + oBB), \\
&\quad (o^{n-1}B + B + B), o^nBB\} \\
&\equiv^+ \{-\frac{3}{2}, -\frac{3}{4}, -\frac{1}{2}*, -\frac{1}{4}, 0, \frac{1}{4}, \frac{1}{2} \mid 1, \frac{5}{4}, \frac{3}{2} * \frac{7}{4}, \frac{9}{4}, \frac{5}{2}\} \\
&\equiv^+ \frac{3}{4}.
\end{aligned}$$

□

Finally, we give the value of the game after they have only played on the leaf farther to the  $x$ .

**Lemma 3.74**  $\forall n \geq 1, Bo^n xoo \equiv^+ \frac{1}{2}$ .

**Proof.** We show the results by induction on  $n$ .

$$\begin{aligned}
Bo^n xoo &= \{Wo^{n-1}xoo, Wo^{n-2}xoo, \bigcup_{i=0}^{n-3} (Bo^iW + Wo^{n-i-3}xoo), \\
&\quad (Bo^{n-2}W + oWoo), (Bo^{n-1}W + W + Wo), \\
&\quad Bo^nWoo, (Bo^nWo + W), Bo^n xW \\
&\quad | (B + Bo^{n-2}xoo), \bigcup_{i=0}^{n-3} (Bo^iB + Bo^{n-i-3}xoo), \\
&\quad (Bo^{n-2}B + oBoo), (Bo^{n-1}B + B + Bo), \\
&\quad Bo^nBoo, (Bo^nBo + B), Bo^n xB\} \\
&\equiv^+ \left\{ -\frac{3}{2}, -\frac{3}{4}, -\frac{1}{2}, -\frac{1}{4}, 0 \mid 1, \frac{5}{4}, \frac{3}{2}, \frac{7}{4}, \frac{5}{2} \right\} \text{ by induction} \\
&\equiv^+ \frac{1}{2}.
\end{aligned}$$

□

With all these values, we are able to give the value of any position of the form  $o^n xoo$ , with  $n$  being at least 3.

**Theorem 3.75 (Berlekamp et al. [4], Conway [10])**

$\forall n \geq 3, o^n xoo \equiv^+ 0$ .

**Proof.**

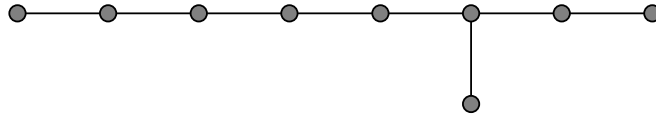
$$\begin{aligned}
o^n xoo &= \{Wo^{n-2}xoo, \bigcup_{i=0}^{n-3} (o^iW + Wo^{n-i-3}xoo), (o^{n-2}W + oWoo), \\
&\quad (o^{n-1}W + W + Wo), o^nWoo, (o^nWo + W), o^n xW \\
&\quad | Bo^{n-2}xoo, \bigcup_{i=0}^{n-3} (o^iB + Bo^{n-i-3}xoo), (o^{n-2}B + oBoo), \\
&\quad (o^{n-1}B + B + Bo), o^nBoo, (o^nBo + B), o^n xB\} \\
&\equiv^+ \left\{ -2, -\frac{3}{2}, -\frac{5}{4}, -1, -\frac{3}{4}, -\frac{1}{2} \mid \frac{1}{2}, \frac{3}{4}, 1, \frac{5}{4}, \frac{3}{2}, 2 \right\} \\
&\equiv^+ 0.
\end{aligned}$$

□

**Example 3.76** Figure 3.15 gives an example of such a tree, representing  $o^5 xoo$ .

We now state the general theorem about grey subdivided stars.

**Theorem 3.77 (Berlekamp et al. [4], Conway [10])** *Let  $T$  be a tree where all vertices are grey, and exactly one vertex has degree at least 3. We call that vertex  $v$  and we root  $T$  at  $v$ .*



**Figure 3.15:** A subdivided star where removing the center changes the value

(i) *If there are exactly three leaves, one at depth 1, another at depth 2 and the last at depth at least 3, or there are an odd number of leaves at depth 1, then the game has value 0.*

(ii) *Otherwise, the game has value  $*$ .*

**Proof.** The first case stated, with three leaves, corresponds exactly to positions of the form  $o^n x o o$ , that we proved have value 0 in Theorem 3.75. On any other case, we can use either Lemma 3.63 or 3.66 together with Theorem 3.57 to remove the vertex  $v$  from the graph without changing the value of the position. As we only leave a disjunctive sum of paths, which all have value 0 apart from isolated vertices, all we need to know is the parity of the number of these isolated vertices to get the value of the position. These isolated vertices were exactly the leaves at depth 1, so if they are in odd number, the value is  $*$ , and otherwise it is 0.  $\square$

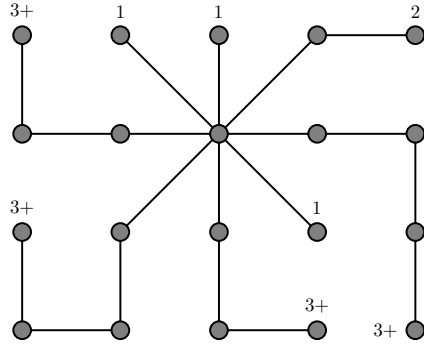
**Example 3.78** Figures 3.16 and 3.17 give examples of subdivided stars where the central vertex can be removed without changing the value: one can apply Theorem 3.57 together with Lemma 3.63 or 3.66 in both cases, on paths ending on leaves of the same depth status, that is the number indicated next to it. In Figure 3.16, the number of leaves at distance 1 from the central vertex, that become isolated vertices after the central vertex is removed, is odd, so the position has value  $*$ . In Figure 3.17, that number is even, so the position has value 0. There are 9 paths on Figure 3.16 and 8 on Figure 3.17 where we can apply Theorem 3.57 to remove the central vertex.

### 3.3.3 Caterpillars

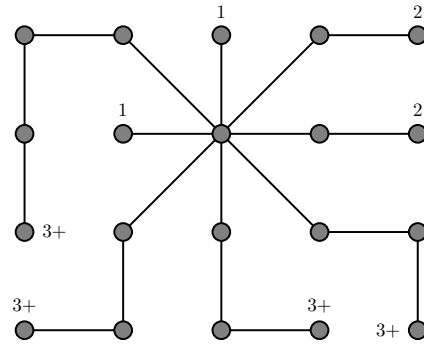
We now work on finding the outcome of grey caterpillars. Recall that a caterpillar is a tree such that the set of vertices of degree at least 2 forms a path. Recall that since all vertices are grey, the position is its own opposite, and has value 0 or  $*$ . We here focus on caterpillars of the form  $x^n$ .

First, when  $n$  is even, the position is symmetric, so it fulfils the conditions of Theorem 3.51.

**Theorem 3.79**  $\forall n \geq 0, x^{2n} \equiv^+ 0$ .



**Figure 3.16:** A subdivided star with value \*



**Figure 3.17:** A subdivided star with value 0

When  $n$  is odd, any of the two involutions on the vertices keeping edges between the images of adjacent vertices would have at least two fixed points: the two central vertices. This is why we need intermediate lemmas. Considering all maximal connected subpositions that players can reach from such a caterpillar seems tedious as they do not seem to simplify as easily as before, so we use a different approach: we find good enough answer for one player and state the other player cannot do better than some value to ensure some bounds on the values of some positions leading to the value of the very first game.

First, we find such values and bounds on a few sets of positions, all stated in a single lemma as the proofs are intertwined.

**Lemma 3.80**

1.  $\forall n \geq 1, x^{2n}B \equiv^+ \frac{3}{4}$  and  $x^{2n-1}B \equiv^+ \frac{1}{2}$ .
2.  $\forall n \geq 0, Bx^{2n}B \equiv^+ 1$  and  $Bx^{2n+1}B \equiv^+ \frac{3}{2}$ .
3.  $\forall n \geq 0, Bx^{2n}W \equiv^+ 0$  and  $Bx^{2n+1}W \equiv^+ *$ .
4.  $\forall n \geq 0, m \geq 0, x^{2n}Bx^{2m}B \geq^+ 1, x^{2n+1}Bx^{2m+1}B \geq^+ 1,$   
 $x^{2n+1}Bx^{2m}B >^+ \frac{3}{4}$  and  $x^{2n}Bx^{2m+1}B >^+ \frac{3}{4}$ .
5.  $\forall n \geq 0, m \geq 0, x^{2n}Bx^{2m}W \geq^+ -\frac{1}{4}, x^{2n+1}Bx^{2m+1}W \geq^+ -\frac{1}{4},$   
 $x^{2n+1}Bx^{2m}W \geq^+ -\frac{1}{2}$  and  $x^{2n}Bx^{2m+1}W \geq^+ -\frac{1}{2}$ .
6.  $\forall n \geq 0, m \geq 0, Bx^{2n}Bx^{2m}B >^+ \frac{3}{2}, Bx^{2n+1}Bx^{2m+1}B >^+ \frac{3}{2},$   
 $Bx^{2n+1}Bx^{2m}B \geq^+ \frac{3}{2}$  and  $Bx^{2n}Bx^{2m+1}B \geq^+ \frac{3}{2}$ .
7.  $\forall n \geq 0, m \geq 0, Bx^{2n}Bx^{2m}W \geq^+ 0, Bx^{2n+1}Bx^{2m+1}W \geq^+ 0,$   
 $Bx^{2n+1}Bx^{2m}W \geq^+ \frac{1}{2}$  and  $Bx^{2n}Bx^{2m+1}W \geq^+ \frac{1}{2}$ .

The proof of this lemma can be found in Appendix B.3. The idea is to list possible moves. Then, we use Theorems 3.53 and 3.55 and induction to give a bound to the value of the position or to the value of a possible answer.

We now show that the answer we propose for Left after some move of Right is winning.

**Lemma 3.81**  $\forall n \geq 0, m \geq 0, x^{2n+1}Bx^{2m+1}Wx \geq^+ 0$ .

**Proof.** We prove Left has a winning strategy in  $x^{2n+1}Bx^{2m+1}Wx$  if Right starts. Consider his possible moves from  $x^{2n+1}Bx^{2m+1}Wx$ . He can move to:

- $B + oBx^{2n-1}Bx^{2m+1}Wx$ , having value at least  $B + x^{2n}Bx^{2m+1}W + x$ , which has value at least  $\frac{1}{2}$ .
- $x^iBo + B + oBx^{2n-i-2}Bx^{2m+1}Wx$ , having value at least  $\frac{1}{2}$  or  $\frac{1}{2}^*$ .
- $x^{2n-1}Bo + B + Bx^{2m+1}Wx$ , having value at least 1 or  $1^*$ .
- $x^{2n+1}B + B + oBx^{2m-1}Wx$ , having value at least  $\frac{3}{4}$ .
- $x^{2n+1}Bx^iBo + B + oBx^{2m-i-2}Wx$ , having value at least  $\frac{1}{4}$  or  $\frac{1}{4}^*$ .
- $x^{2n+1}Bx^{2m-1}Bo + B + x$ , having value at least 1 or  $1^*$ .
- $x^{2n+1}Bx^{2m}Bo + Bo$ , having value at least  $\frac{1}{2}$  or  $\frac{1}{2}^*$ .
- $x^{2n+1}Bx^{2m+1} + B$ , having value at least 1 or  $1^*$ .
- $x^iBx^{2n-i}Bx^{2m+1}Wx$ . Then Left can answer to  $x^iBx^{2n-i}BWx^{2m}Wx$ , which has value at least 0.
- $x^{2n+1}BBx^{2m}Wx$ , having value at least  $x^{2n+1} + Bx^{2m} + Wx$ , which has value at least  $\frac{1}{4}$  or  $\frac{1}{4}^*$ .
- $x^{2n+1}Bx^iBx^{2m-i}Wx$ . Then left can answer to  $x^{2n+1}Bx^iBWx^{2m-i-1}Wx$ , which has value at least 0 when  $i$  is odd, or to  $x^{2n+1}Bx^{i-1}WBx^{2m-i}Wx$ , which has value at least 0 when  $i$  is even.
- $x^{2n+1}Bx^{2m}BWx$ , having value more than  $\frac{3}{4}$ .
- $x^{2n+1}Bx^{2m+1}WB$ , having value at least  $\frac{1}{4}$ .

□

We now state the theorem, that almost all caterpillars of the form  $x^n$  have value 0.

**Theorem 3.82**  $\forall n \neq 3, x^n \equiv^+ 0$ , and  $xxx \equiv^+ *$ .

**Proof.** When  $n$  is even, it is true by Theorem 3.79. When  $n \leq 3$ , it is true by Theorem 3.77. Now assume  $n \geq 5$  is odd. We prove the second player has a winning strategy in  $x^n$ . Without loss of generality, we may assume Right starts the game and consider his possible moves from  $x^n$ . He can move to:

- $B + oBx^{n-2}$ , having value at least 1.
- $x^iBo + B + oBx^{n-i-3}$ , having value at least 1 or  $1^*$ .
- $x^{2i}Bx^{n-2i-1}$ . Without loss of generality, we may assume  $2i \geq \frac{n-1}{2} \geq 2$ . Then Left can answer to  $x^{2i-1}WBx^{n-2i-1}$ , which has value  $\frac{1}{4}$ .
- $x^{2i+1}Bx^{n-2i-2}$ . Without loss of generality, we may assume  $2i+1 \geq \frac{n-1}{2} \geq 2$ . Then Left can answer to  $xWx^{2i-1}Bx^{n-2i-2}$ , which has value at least 0.

□

We now consider other caterpillars. Whenever one vertex is adjacent to two leaves or more, we can remove that vertex for the game without changing its value, using Lemma 3.63 and Theorem 3.57. Theorems 3.61 and 3.82 are then enough to conclude most cases, but the value of arbitrary caterpillars is still an open problem.

**Example 3.83** Figure 3.18 shows an example of a “more general” caterpillar of which we can determine the value using our results. On each step, the vertex we can remove using Theorem 3.57 is all grey (without the black line surrounding it like the other vertices). We added a 1 close to its neighbouring leaves, to see where the theorem can be applied. The dashed line is there to ensure that anyone, by moving the incident vertex through it, sees that last component as  $x^4$ . On the resulting graph, there are five isolated vertices, each having value  $*$ , an  $x^3$  and an  $x^4$ , having respectively value  $*$  and 0, so the position has value 0. We get that 0 is the value of the original position, on a connected caterpillar.

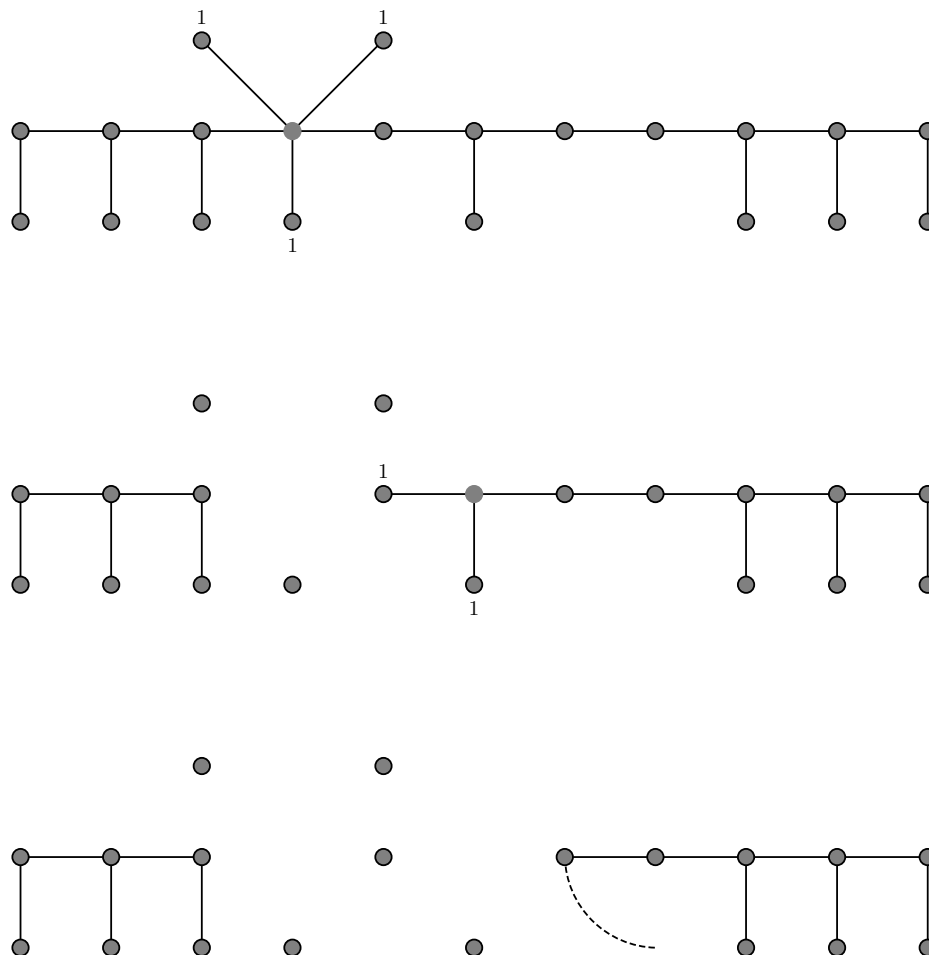
**Example 3.84** Figure 3.19 shows an example of a caterpillar which is not of the form  $x^n$  and that cannot be simplified using Lemma 3.63 and Theorem 3.57. Therefore, our results are not sufficient to give the value of this position.

### 3.3.4 Cographs

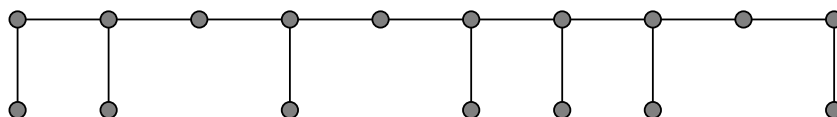
We give an algorithm for computing in linear time the value of a cograph where no vertex is reserved. First, we build the associated cotree. Then, at each node  $u$  of the cotree starting from the leaves, we label the node by the size of the maximum independent set and the value of the graph below it as follows:

1. If  $u$  is a leaf, then the maximum independent set has size 1 and the value is  $*$ .
2. If  $u$  corresponds to a disjoint union of two cographs, the size of the maximum independent set and the value are the sum of the values of these two cographs.
3. Otherwise,  $u$  corresponds to a join of two cographs, the size of the maximum independent set is the maximum of the ones of these two cographs, and the value is the value of the cograph which has the maximum independent set of greater size, except that the value is 0 when their respective maximum independent sets have the same size.





**Figure 3.18:** Finding the value of a caterpillar by removing vertices according to Lemma 3.63 and Theorem 3.57



**Figure 3.19:** A caterpillar where our results cannot conclude alone

**Proof.** We only need to ensure by induction that if the value of the graph is  $*$ , any player who starts the game has a winning strategy such that their first move is on a vertex contained in a maximum independent set. When the graph is a single vertex the result is true. When the graph is a disjoint union of two cographs, the first player has a winning move only if one component has value  $*$  and the other component has value 0. A winning move is to move the component of value  $*$  to value 0, and there exists such a move on a vertex contained in a maximum independent set of that component by induction. That vertex is also contained in a maximum independent set of the whole graph, so the result is true. When the graph is a join of two cographs, the first player has a winning move only if the component having the maximum independent set of greater size has value  $*$ . A winning move is to move that component of value  $*$  to value 0, and there exists such a move on a vertex contained in a maximum independent set of that component by induction. That vertex is also contained in a maximum independent set of the whole graph, so the result is true.  $\square$

**Example 3.85** Figures 3.20 and 3.21 illustrate the algorithm. Figure 3.20 is a cograph with all vertices grey. Figure 3.21 is the associated cotree: the leaves correspond to the vertices of the cograph; the  $D$  internal nodes indicate when two cographs are gathered into one through disjoint union; the  $J$  internal nodes indicate when two cographs are gathered into one through join. Next to each node, there is a couple indicating the value and the size of a maximum independent set of the subgraph induced by the vertices below that node.

---

## 3.4 Perspectives

---

In this chapter, we considered the games TIMBUSH, TOPPLING DOMINOES and COL.

In the case of TIMBUSH, we gave an algorithm to find the outcome of any orientation of paths with coloured arcs and an algorithm to find the outcome of any directed graph with arcs coloured black or white.

Note that if the connected directed graph we consider contains a 2-edge-connected component, any arc of that component is a winning move, but if all these arcs are black, or they are all white, we do not know if the other player have a winning move.

Hence we ask the following questions.

**Question 3.86** *Can one find a polynomial-time algorithm which gives the outcome of any TIMBUSH position on directed graphs with coloured arcs?*

Another difference in result with TIMBER is that we do not give the value of any orientation of paths. That problem is already non-trivial if we only look at orientation of paths with arcs coloured black or white.

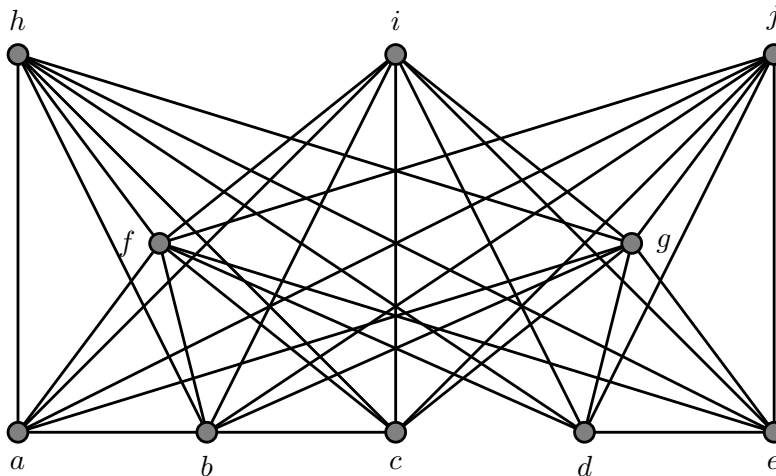


Figure 3.20: A cograph

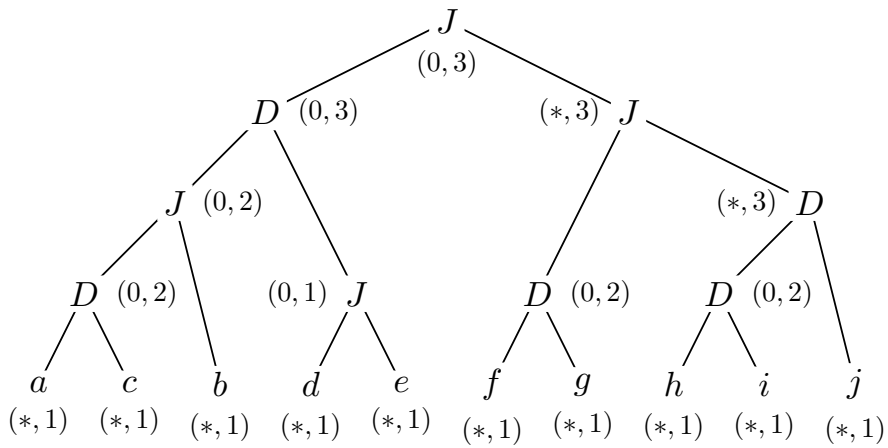


Figure 3.21: Its corresponding cotree, labelled by our algorithm

**Question 3.87** *Is there a polynomial-time algorithm for finding the value of any TIMBUSH position on directed paths with arcs coloured black or white?*

In the case of TOPPLING DOMINOES, we proved that for any value of the form  $\{a|b\}$  with  $a \geq b$ ,  $\{a||b|c\}$  with  $a \geq b \geq c$ , and  $\{a|b||c|d\}$  with  $a \geq b > c \geq d$ , there exists a TOPPLING DOMINOES position on a single row that have this value. We even found all representatives of positions of the form  $\{a|b\}$ , which leads us to the following conjectures.

**Conjecture 3.88** *Let  $a \geq b \geq c$  be numbers and  $G$  a TOPPLING DOMINOES position with value  $\{a|\{b|c\}\}$ . Then  $G$  is  $aLRbRLc$ ,  $aEbRLc$  or one of their reversal. Furthermore, if  $a = b$ , then  $G$  is  $aLRbRLc$  or its reversal.*

**Conjecture 3.89** *Let  $a \geq b > c \geq d$  be numbers and  $G$  a TOPPLING DOMINOES position with value  $\{\{a|b\}|\{c|d\}\}$ . Then  $G$  is  $bRLaLRdRLc$ ,  $bRLaEdRLc$  or one of their reversal.*

In the case of COL, we restated some known results and went further in finding the values of most grey caterpillars and all grey cographs. Nevertheless, the problem on general trees is still open.

**Question 3.90** *What is the complexity of finding the outcome of any COL position on a tree?*

## Chapter 4

# Misère games

The misère version of a game is a game with the same game tree where the victory condition is reversed, that is the first player unable to move when it is their turn wins. Under the misère convention, the equivalence of two games is very limited, as proved by Mesdal and Ottaway [25] and Siegel in [38]. In particular, the equivalence class of 0 is restricted to 0 itself, which shows a serious contrast with the normal convention where any game having outcome  $\mathcal{P}$  is equivalent to 0. This is probably why Plambeck and Siegel defined in [32, 34] an equivalence relationship under restricted universes, leading to a breakthrough in the study of misère play games.

**Definition 4.1 (Plambeck and Siegel [32, 34])** Let  $\mathcal{U}$  be a universe of games,  $G$  and  $H$  two games (not necessarily in  $\mathcal{U}$ ). We say  $G$  is greater than or equal to  $H$  modulo  $\mathcal{U}$  in misère play and write  $G \geq^- H \pmod{\mathcal{U}}$  if  $o^-(G + X) \geq o^-(H + X)$  for every  $X \in \mathcal{U}$ . We say  $G$  is equivalent to  $H$  modulo  $\mathcal{U}$  in misère play and write  $G \equiv^- H \pmod{\mathcal{U}}$  if  $G \geq^- H \pmod{\mathcal{U}}$  and  $H \geq^- G \pmod{\mathcal{U}}$ .

For instance, Plambeck and Siegel [32, 33, 34] considered the universe of all positions of given games, especially octal games. Other universes have been considered, including the universes  $\mathcal{A}$  of sums of alternating games [27],  $\mathcal{I}$  of impartial games [4, 10],  $\mathcal{D}$  of dicot games [2, 26, 24],  $\mathcal{E}$  of dead-ending games [28], and  $\mathcal{G}$  of all games [38]. These classes are ordered by inclusion as follows:

$$\mathcal{I} \subset \mathcal{D} \subset \mathcal{E} \subset \mathcal{G}.$$

To simplify notation, we use from now on  $\geq_{\mathcal{U}}^-$  and  $\equiv_{\mathcal{U}}^-$  to denote superiority and equivalence modulo the universe  $\mathcal{U}$ . Observe also that if  $\mathcal{U}$  and  $\mathcal{U}'$  are two universes with  $\mathcal{U} \subseteq \mathcal{U}'$ , then for any two games  $G$  and  $H$ ,  $G \leq_{\mathcal{U}}^- H$  whenever  $G \leq_{\mathcal{U}'}^- H$ .

Given a universe  $\mathcal{U}$ , we can determine the equivalence classes under  $\equiv_{\mathcal{U}}^-$  and form the quotient semi-group  $\mathcal{U}/\equiv_{\mathcal{U}}^-$ . This quotient, together with the tetra-partition of elements into the sets  $\mathcal{L}$ ,  $\mathcal{N}$ ,  $\mathcal{P}$  and  $\mathcal{R}$ , is called the *misère monoid* of the set  $\mathcal{U}$ , denoted  $\mathcal{M}_{\mathcal{U}}$ . It is usually desirable to have the set of games  $\mathcal{U}$  closed under disjunctive sum, taking options and conjugates; when a set of games is not already thus closed, we often consider its closure under these three operations, that we call the closure of the set.

A *Left end* is a game where Left has no move, and a *Right end* is a game where Right has no move. In misère play, end positions are important positions to see for a set of games if their conjugates are their opposites, that is if  $G + \overline{G} \equiv_{\mathcal{U}}^- 0$ .

**Lemma 4.2** *Let  $\mathcal{U}$  be any game universe closed under conjugation and followers, and let  $S$  be a set of games closed under followers. If  $G + \overline{G} + X \in \mathcal{L}^- \cup \mathcal{N}^-$  for every game  $G \in S$  and every Left end  $X \in \mathcal{U}$ , then  $G + \overline{G} \equiv_{\mathcal{U}}^- 0$  for every  $G \in S$ .*

**Proof.** Let  $S$  be a set of games with the given conditions. Since  $\mathcal{U}$  is closed under conjugation, by symmetry we also have  $G + \overline{G} + X \in \mathcal{R}^- \cup \mathcal{N}^-$  for every  $G \in S$  and every Right end  $X \in \mathcal{U}$ . Let  $G$  be any game in  $S$  and assume inductively that  $H + \overline{H} \equiv_{\mathcal{U}}^- 0$  for every follower  $H$  of  $G$ . Let  $K$  be any game in  $\mathcal{U}$ , and suppose Left wins  $K$ . We must show that Left can win  $G + \overline{G} + K$ . Left should follow her usual strategy in  $K$ ; if Right plays in  $G$  or  $\overline{G}$  to, say,  $G^R + \overline{G} + K'$ , with  $K' \in \mathcal{L}^- \cup \mathcal{P}^-$ , then Left copies his move and wins as the second player on  $G^R + \overline{G}^L + K' = G^R + \overline{G}^R + K' \equiv_{\mathcal{U}}^- 0 + K'$ , by induction. Otherwise, once Left runs out of moves in  $K$ , say at a Left end  $K''$ , she wins playing next on  $G + \overline{G} + K''$  by assumption.  $\square$

The universes we focus on in this chapter are the dicot universe, denoted  $\mathcal{D}$ , and the dead-ending universe, denoted  $\mathcal{E}$ . A game is said to be *dicot* either if it is  $\{\cdot|\cdot\}$  or if it has both Left and Right options and all these options are dicot. A Left (Right) end is a *dead end* if every follower is also a Left (Right) end. A game is said to be *dead-ending* if all its end followers are dead ends.

As with normal games, to simplify proofs, we often do not state results on the conjugates of games on which we proved similar results. With the following proposition, we justify this possibility and we observe that passing by conjugates in the universe of conjugates, any result on the Left options can be extended to the Right options, and vice versa.

**Proposition 4.3** *Let  $G$  and  $H$  be any two games, and  $\mathcal{U}$  a universe. Denote by  $\overline{\mathcal{U}}$  the universe of the conjugates of the elements of  $\mathcal{U}$ . If  $G \geq_{\mathcal{U}}^- H$ , then  $\overline{G} \leq_{\overline{\mathcal{U}}}^- \overline{H}$ . As a consequence,  $G \equiv_{\mathcal{U}}^- H \iff \overline{G} \equiv_{\overline{\mathcal{U}}}^- \overline{H}$ .*

**Proof.** For a game  $X \in \overline{\mathcal{U}}$ , suppose Left can win  $\overline{G} + X$  playing first (respectively second). We show that she also has a winning strategy on  $\overline{H} + X$ . Looking at conjugates, Right can win  $\overline{\overline{G} + X} = G + \overline{X}$ . As  $\overline{X} \in \mathcal{U}$  and  $G \geq_{\mathcal{U}}^- H$ , Right can win  $H + \overline{X}$ . Thus Left can win  $\overline{H + \overline{X}} = \overline{H} + X$  and  $\overline{G} \leq_{\overline{\mathcal{U}}}^- \overline{H}$ .  $\square$

Relying on this proposition, we often give the results only on Left options in the following, keeping in mind that they naturally extend to the Right

options provided the result holds on the universe of conjugate. This is always the case in the following since we either prove our results on all universes, or on the universe  $\mathcal{D}$  of dicots or  $\mathcal{E}$  of dead-endings which are their own conjugates.

Considering a game, it is quite natural to observe that adding an option to a player who already has got some can only improve his position (hand-tying principle). It was already proved in [25] in the universe  $\mathcal{G}$  of all games. As a consequence, this is true for any subuniverse  $\mathcal{U}$  of  $\mathcal{G}$ .

**Proposition 4.4** *Let  $G$  be a game with at least one Left option,  $S$  a set of games and  $\mathcal{U}$  a universe of games. Let  $H$  be the game defined by  $H^{\mathbf{L}} = G^{\mathbf{L}} \cup S$  and  $H^{\mathbf{R}} = G^{\mathbf{R}}$ . Then  $H \geq_{\mathcal{U}} G$ .*

In this chapter, we frequently use the fact that, when  $H$  has an additive inverse  $H'$  modulo  $\mathcal{U}$ ,  $G \geq_{\mathcal{U}} H$  if and only if  $G + H' \geq_{\mathcal{U}} 0$  when all these games are elements of  $\mathcal{U}$ .

**Proposition 4.5** *Let  $\mathcal{U}$  be a universe of game closed under disjunctive sum,  $H, H' \in \mathcal{U}$  be two games being inverses to each other modulo  $\mathcal{U}$ . Then for any game  $G \in \mathcal{U}$ , we have  $G \geq_{\mathcal{U}} H$  if and only if  $G + H' \geq_{\mathcal{U}} 0$ .*

**Proof.** Assume first  $G \geq_{\mathcal{U}} H$ . Let  $X \in \mathcal{U}$  a game such that Left wins  $X$ . Then, as  $H + H' \equiv_{\mathcal{U}} 0$ , Left wins  $H + H' + X$ . As  $H' + X \in \mathcal{U}$  and  $G \geq_{\mathcal{U}} H$ , Left wins  $G + H' + X$ . Hence  $G + H' \geq_{\mathcal{U}} 0$ .

Assume now  $G + H' \geq_{\mathcal{U}} 0$ . Let  $X \in \mathcal{U}$  a game such that Left wins  $H + X$ . As  $H + X \in \mathcal{U}$  and  $G + H' \geq_{\mathcal{U}} 0$ , Left wins  $G + H' + H + X$ . Then, as  $G + X \in \mathcal{U}$  and  $H + H' \equiv_{\mathcal{U}} 0$ , Left wins  $G + X$ . Hence  $G \geq_{\mathcal{U}} H$ .  $\square$

In this chapter, we first consider the games we studied previously, now under misère convention, and study some misère universes. Section 4.1 is dedicated the specific games we mentioned, on which we give complexity results and compare them with their normal version counterparts. In Section 4.2, we study the universe of dicot games, define a canonical form for them, and count the number of dicot games in canonical form born by day 3. In Section 4.3, we study the universe of dead-ending games, in particular dead ends, normal canonical-form numbers and a family of games that would be equivalent to 0 modulo the dead-ending universe.

The results presented in Subsection 4.1.1 are a joint work with Sylvain Gravier and Simon Schmidt. The results presented in Section 4.1.2 are about to appear in [16] (joint work with Éric Duchêne). The results presented in Subsection 4.1.3 appeared in [29] (joint work with Richard Nowakowski, Emily Lamoureux, Stephanie Mellon and Timothy Miller). The results presented in Subsection 4.1.6 are a joint work with Paul Dorbec and Éric Sopena. The results presented in Section 4.2 are a joint work with Paul Dorbec, Aaron Siegel and Éric Sopena [15]. The results presented in Section 4.3 appeared in [28] (joint work with Rebecca Milley).

---

<b>4.1</b>	<b>Specific games</b>	<b>104</b>
4.1.1	GEOGRAPHY	105
4.1.2	VERTEXNIM	111
4.1.3	TIMBER	113
4.1.4	TIMBUSH	116
4.1.5	TOPPLING DOMINOES	117
4.1.6	COL	119
<b>4.2</b>	<b>Canonical form of dicot games</b>	<b>126</b>
4.2.1	Definitions and universal properties	127
4.2.2	Canonical form of dicot games	130
4.2.3	Dicot misère games born by day 3	136
4.2.4	Sums of dicots can have any outcome	146
<b>4.3</b>	<b>A peek at the dead-ending universe</b>	<b>147</b>
4.3.1	Preliminary results	149
4.3.2	Integers and other dead ends	151
4.3.3	Numbers	153
4.3.4	Zeros in the dead-ending universe	160
<b>4.4</b>	<b>Perspectives</b>	<b>161</b>

---



---

## 4.1 Specific games

---

We start by looking at the games we studied in the previous chapters, with the addition of one game, GEOGRAPHY, and give some results about their misère version. In particular, we see that some games, such as VERTEXNIM, behave similarly in their misère and normal version, while others, such as COL, ask for a different strategy from the players. The complexity of finding the outcome of a position might also be different in some games.

In this section, we define the impartial game GEOGRAPHY and show the PSPACE-completeness of its variants under the misère convention. We then tract our results on VERTEXNIM from normal play to misère play, find the misère outcome of TIMBER positions on oriented paths, reduce TIMBUSH positions to forests, give the misère outcome of any single row of TOPPLING DOMINOES and the misère monoid of TOPPLING DOMINOES positions without grey dominoes, and the misère outcome of any COL position on a grey subdivided star.



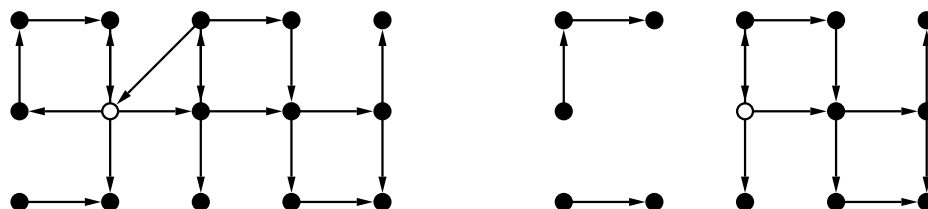


Figure 4.1: Playing a move in VERTEX GEOGRAPHY

#### 4.1.1 GEOGRAPHY

GEOGRAPHY is an impartial game played on a directed graph with a token on a vertex. There exist two variants of the game: VERTEX GEOGRAPHY and EDGE GEOGRAPHY. A move in VERTEX GEOGRAPHY is to slide the token through an arc and delete the vertex on which the token was. A move in EDGE GEOGRAPHY is to slide the token through an arc and delete the edge on which the token just slid. In both variants, the game ends when the token is on a sink.

A position is described by a graph and a vertex indicating where the token is.

**Example 4.6** Figure 4.1 gives an example of a move in VERTEX GEOGRAPHY. The token is on the white vertex. The player whose turn it is chooses to move the token through the arc to the right. After the vertex is removed, some vertices (on the left of the directed graph) are no longer reachable. Figure 4.2 gives an example of a move in EDGE GEOGRAPHY. The token is on the white vertex. The player whose turn it is chooses to move the token through the arc to the right. After that move, it is possible to go back to the previous vertex immediately as the arc in the other direction is still in the game.

GEOGRAPHY can also be played on an undirected graph  $G$  by seeing it as a symmetric directed graph where the vertex set remains the same and the arc set is  $\{(u, v), (v, u) \mid (u, v) \in E(G)\}$ , except that in the case of EDGE GEOGRAPHY, going through an edge  $(u, v)$  would remove both the arc  $(u, v)$  and the arc  $(v, u)$  of the directed version.

**Example 4.7** Figure 4.3 gives an example of a move in EDGE GEOGRAPHY on an undirected graph. The token is on the white vertex. The player whose turn it is chooses to move the token through the arc to the right. After that move, it is not possible to go back to the previous vertex immediately as the edge between the two vertices has been removed from the game.

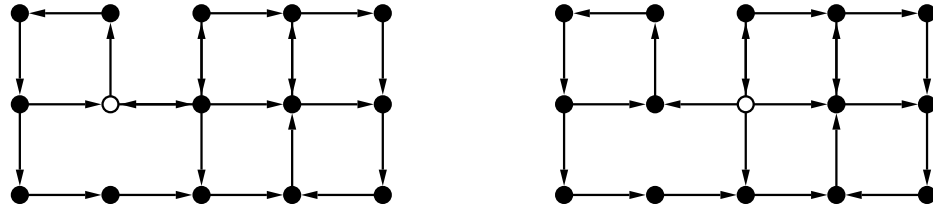


Figure 4.2: Playing a move in EDGE GEOGRAPHY

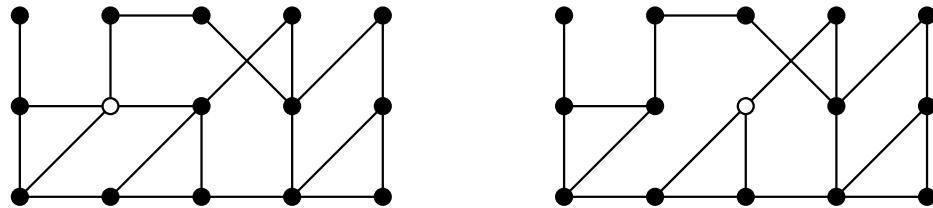


Figure 4.3: Playing a move in EDGE GEOGRAPHY on an undirected graph

A GEOGRAPHY position is denoted  $(G, u)$  where  $G$  is the graph, or the directed graph, on which the game is played, and  $u$  is the vertex of  $G$  where the token is.

Lichtenstein and Sipser [22] proved that finding the normal outcome of a VERTEX GEOGRAPHY position on a directed graph is PSPACE-complete. Schaefer proved that finding the normal outcome of an EDGE GEOGRAPHY position on a directed graph is PSPACE-complete. On the other hand, Fraenkel, Scheinerman and Ullman [18] gave a polynomial algorithm for finding the normal outcome of a VERTEX GEOGRAPHY position on an undirected graph, and they also proved that finding the normal outcome of an EDGE GEOGRAPHY position on an undirected graph is PSPACE-complete.

We here look at these games under the misère convention, and show the problem is PSPACE-complete both on directed graphs and on undirected graphs, for both VERTEX GEOGRAPHY and EDGE GEOGRAPHY.

First note that all these problems are in PSPACE as the length of a game of VERTEX GEOGRAPHY is bounded by the number of its vertices, and the length of a game of EDGE GEOGRAPHY is bounded by the number of its

edges.

We start with VERTEX GEOGRAPHY on directed graphs, where the reduction is quite natural, we just add a losing move to every position of the previous graph, move that the players will avoid until it becomes the only available move, that is when the original game would have ended.

**Theorem 4.8** *Finding the misère outcome of a VERTEX GEOGRAPHY position on a directed graph is PSPACE-complete.*

**Proof.** We reduce the problem from normal VERTEX GEOGRAPHY on directed graphs.

Let  $G$  be a directed graph. Let  $G'$  be the directed graph with vertex set

$$V(G') = \{u_1, u_2 | u \in V(G)\}$$

and arc set

$$A(G') = \{(u_1, v_1) | (u, v) \in A(G)\} \cup \{(u_1, u_2) | u \in V(G)\}$$

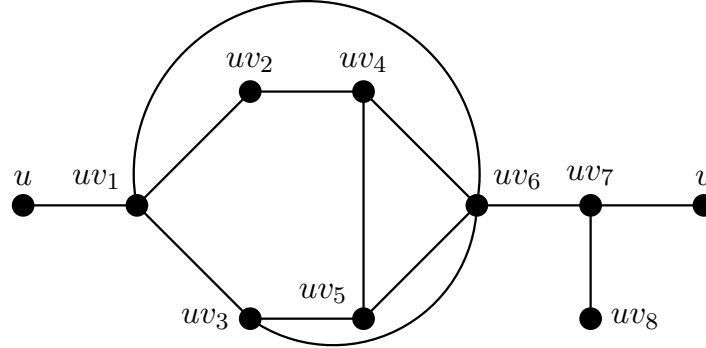
that is the graph where each vertex of  $G$  gets one extra out-neighbour that was not originally in the graph. We claim that the normal outcome of  $(G, v)$  is the same as the misère outcome of  $(G', v_1)$  and show it by induction on the number of vertices in  $G$ .

If  $V(G) = \{v\}$ , then both  $(G, v)$  and  $(G', v_1)$  are  $\mathcal{P}$ -positions. Assume now  $|V(G)| \geq 2$ . Assume first  $(G, v)$  is an  $\mathcal{N}$ -position. There is a winning move in  $(G, v)$  to  $(\tilde{G}, u)$ . We show that moving from  $(G', v_1)$  to  $(\hat{G}', u_1)$  is a winning move. We have  $V(\hat{G}') = V(\tilde{G}') \cup \{v_2\}$  and  $A(\hat{G}') = A(\tilde{G}')$ . As the vertex  $v_2$  is disconnected from the vertex  $u_1$  in  $\hat{G}'$ , the games  $(\hat{G}', u_1)$  and  $(\tilde{G}', u_1)$  share the same game tree, and they both have outcome  $\mathcal{P}$  by induction. Hence  $(G', v_1)$  has outcome  $\mathcal{N}$ . Now assume  $(G, v)$  is a  $\mathcal{P}$ -position. For the same reason as above, moving from  $(G', v_1)$  to any  $(\hat{G}', u_1)$  would leave a game whose misère outcome is the same as the normal outcome of a game obtained after playing a move in  $(G, v)$ , which is  $\mathcal{N}$ . The only other available move is from  $(G', v_1)$  to  $(\hat{G}', v_2)$ , which is a losing move as it ends the game. Hence  $(G', v_1)$  has outcome  $\mathcal{P}$ .  $\square$

The proof in [22] actually works even if we only consider planar bipartite directed graphs with maximum degree 3. As our reduction keeps the planarity and the bipartition, only adds vertices of degree 1 and increases the degree of vertices by 1, we get the following corollary.

**Corollary 4.9** *Finding the misère outcome of a VERTEX GEOGRAPHY position on a planar bipartite directed graph with maximum degree 4 is PSPACE-complete.*

For undirected graphs, adding a new neighbour to each vertex would work the same, but the normal version of VERTEX GEOGRAPHY on undirected



**Figure 4.4:** The arc gadget

graph is solvable in polynomial time, so we reduce from directed graphs, and replace each arc by an undirected gadget. That gadget would need to act like an arc, that is a player who would want to take it in the wrong direction would lose the game, as well as a player who would want to take it when the vertex at the other end has already been played, and we want to force that a player who takes it is the player who moves the token to the other end, so that it would be the other player's turn when the token reach the end vertex of the arc gadget, as in the original game.

**Theorem 4.10** *Finding the misère outcome of a VERTEX GEOGRAPHY position on an undirected graph is PSPACE-complete.*

**Proof.** We reduce the problem from normal VERTEX GEOGRAPHY on directed graphs.

We introduce a gadget that will replace any arc  $(u, v)$  of the original directed graph, and add a neighbour to each vertex to have an undirected graph whose misère outcome is the normal outcome of the original directed graph.

Let  $G$  be a directed graph. Let  $G'$  be the undirected graph with vertex set

$$V(G') = \{u, u' \mid u \in V(G)\} \cup \{uv_i \mid (u, v) \in A(G), i \in \llbracket 1; 8 \rrbracket\}$$

and edge set

$$E(G') = \{(u, uv_1), (uv_1, uv_2), (uv_1, uv_3), (uv_1, uv_6), (uv_2, uv_4), (uv_3, uv_5), (uv_3, uv_6), (uv_4, uv_5), (uv_4, uv_6), (uv_5, uv_6), (uv_6, uv_7), (uv_7, uv_8), (uv_7, v) \mid (u, v) \in A(G)\} \cup \{(u, u') \mid u \in V(G)\}$$

that is the graph where every arc  $(u, v)$  of  $G$  has been replaced by the gadget of Figure 4.4, identifying both  $u$  vertices and both  $v$  vertices, and each vertex

of  $G$  gets one extra neighbour that was not originally in the graph. We claim that the normal outcome of  $(G, u)$  is the same as the misère outcome of  $(G', u)$  and show it by induction on the number of vertices in  $G$ .

If  $V(G) = u$ , then  $(G, u)$  is a normal  $\mathcal{P}$ -position. In  $(G', u)$  the first player can only move to  $(\widehat{G}', u')$  where the second player wins as he cannot move.

Now assume  $|V(G)| \geq 2$ .

We first show that no player wants to move the token from  $v$  to any  $wv_7$ , whether  $w$  has been played or not. We will only prove it for moving the token from  $v$  to some  $wv_7$  where  $w$  is still in the game, as the other case is similar. First note that if  $w$  is removed from the game in the sequence of move following that first move, as  $v$  is already removed, all vertices of the form  $wv_i$  would be disconnected from the token, and therefore unreachable. Hence whether the move from  $wv_1$  to  $w$  is winning does not depend on the set of vertices deleted in that sequence, and it is possible to argue the two cases. Assume the first player moved the token from  $v$  to any  $wv_7$ . Then the second player can move the token to  $wv_6$ . From there, the first player has four choices. If she goes to  $wv_1$ , the second player answers to  $wv_2$ , then the rest of the game is forced and the second player wins. If she goes to  $wv_4$ , he answers to  $wv_2$  where she can only move to  $wv_1$ , and let him go to  $wv_3$  where she is forced to play to  $wv_5$  and lose. The case where she goes to  $wv_5$  is similar. In the case where she goes to  $wv_3$ , we argue two cases: if the move from  $wv_1$  to  $w$  is winning, he answers to  $wv_5$ , where all is forced until he gets the move to  $w$ ; if that move is losing, he answers to  $wv_1$ , from where she can either go to  $w$ , which is a losing move by assumption, or go to  $wv_2$  where every move is forced until she loses.

We now show that no player wants to move the token from  $v$  to any  $vv_1$  where  $w$  has already been played. Assume the first player just played that move. Then the second player can move the token to  $vv_3$ . From there, the first player have two choices. If she plays to  $vv_6$ , he answers to  $vv_4$ , where she can only end the game and lose. If she plays to  $vv_5$ , he answers to  $vv_4$ , where the move to  $vv_2$  is immediately losing, and the move to  $vv_6$  forces the token to go to  $vv_7$  and then  $vv_8$  where she loses.

Assume first that  $(G, u)$  is an  $\mathcal{N}$ -position. There is a winning move in  $(G, u)$  to some  $(\widetilde{G}, v)$ . We show that moving the token from  $u$  to  $uv_1$  in  $G'$  is a winning move for the first player. From there, the second player has three choices. If he moves the token to  $uv_6$ , the first player answers to  $uv_3$ , then the rest of the game is forced and the first player wins. If he moves the token to  $uv_2$ , the first player answers to  $uv_4$ , where the second player again has two choices: either he goes to  $uv_6$ , she answers to  $uv_5$  where he is forced to lose by going to  $uv_3$ ; or he goes to  $uv_5$ , she answers to  $uv_6$  where the move to  $uv_3$  is immediately losing and the move to  $uv_7$  is answered to a game  $(\widehat{G}', v)$ . As  $u'$  and all vertices of the form  $uv_i$  are either played or disconnected from  $v$  in  $\widehat{G}'$ , the only differences in the possible moves in (followers of) the games

$(\widehat{G}', v)$  and  $(\widetilde{G}', v)$  are moves from a vertex  $w$  to  $wu_1$  or to  $wu_7$ , so they both have outcome  $\mathcal{P}$  by induction. The case where he chooses to move the token to  $uv_3$  is similar. Hence  $(G', u)$  is an  $\mathcal{N}$ -position.

Now assume  $(G, u)$  is a  $\mathcal{P}$ -position. Then any  $(\widetilde{G}, v)$  that can be obtained after a move from  $(G, u)$  is an  $\mathcal{N}$ -position. Moving the token to  $u'$  in  $G'$  is immediately losing, so we may assume the first player moves it to some  $uv_1$ , where the second player answers to  $uv_3$ . From there the first player has two choices. If she goes to  $uv_6$ , the second player answers by going to  $uv_4$ , where both available moves are immediately losing. If she goes to  $uv_5$ , he answers to  $uv_4$ , where the move to  $uv_2$  is immediately losing, and the move to  $uv_6$  is answered to  $uv_7$ , where again the move to  $uv_8$  is immediately losing, so we may assume he moves the token to  $v$ . As  $u'$  and all vertices of the form  $uv_i$  are either played or disconnected from  $v$  in  $\widehat{G}'$ , the only differences in the possible moves in (followers of) the games  $(\widehat{G}', v)$  and  $(\widetilde{G}', v)$  are moves from a vertex  $w$  to  $wu_1$  or to  $wu_7$ , so they both have outcome  $\mathcal{N}$  by induction. Hence  $(G', u)$  is a  $\mathcal{P}$ -position.  $\square$

Again, using the fact that the proof in [22] actually works even if we only consider planar bipartite directed graphs with maximum degree 3, as our reduction keeps the planarity since the gadget is planar with the vertices we link to the rest of the graph being on the same face, only adds vertices of degree at most 5 and increases the degree of vertices by 1, we get the following corollary.

**Corollary 4.11** *Finding the misère outcome of a VERTEX GEOGRAPHY position on a planar undirected graph with degree at most 5 is PSPACE-complete.*

Though misère play is generally considered harder to solve than normal play, the feature that makes it hard is the fact that disjunctive sums do not behave as nicely as in normal play, and GEOGRAPHY is a game that does not split into sums. Hence the above result appears a bit surprising as it was not expected.

We now look at EDGE GEOGRAPHY where the reductions are very similar to the one for VERTEX GEOGRAPHY on directed graphs.

We start with the undirected version.

**Theorem 4.12** *Finding the misère outcome of an EDGE GEOGRAPHY position on an undirected graph is PSPACE-complete.*

**Proof.** We reduce the problem from normal EDGE GEOGRAPHY on undirected graphs.

Let  $G$  be an undirected graph. Let  $G'$  be the undirected graph with vertex set

$$V(G') = \{u_1, u_2 | u \in V(G)\}$$

and edge set

$$E(G') = \{(u_1, v_1) | (u, v) \in E(G)\} \cup \{(u_1, u_2) | u \in V(G)\}$$

that is the graph where each vertex of  $G$  gets one extra neighbour that was not originally in the graph. We claim that the normal outcome of  $(G, v)$  is the same as the misère outcome of  $(G', v_1)$  and show it by induction on the number of vertices in  $G$ . The proof is similar to the proof of Theorem 4.8  $\square$

We now look at EDGE GEOGRAPHY on directed graphs.

**Theorem 4.13** *Finding the misère outcome of an EDGE GEOGRAPHY position on a directed graph is PSPACE-complete.*

**Proof.** We reduce the problem from normal EDGE GEOGRAPHY on directed graphs.

Let  $G$  be a directed graph. Let  $G'$  be the directed graph with vertex set

$$V(G') = \{u_1, u_2 | u \in V(G)\}$$

and arc set

$$A(G') = \{(u_1, v_1) | (u, v) \in A(G)\} \cup \{(u_1, u_2) | u \in V(G)\}$$

that is the graph where each vertex of  $G$  gets one extra out-neighbour that was not originally in the graph. We claim that the normal outcome of  $(G, v)$  is the same as the misère outcome of  $(G', v_1)$  and show it by induction on the number of vertices in  $G$ . The proof is similar to the proof of Theorem 4.8  $\square$

#### 4.1.2 VERTEXNIM

In VERTEXNIM, the misère version seems to behave like the normal version. The results we obtained in Section 2.1 are extensible to misère games.

First we look at ADJACENT NIM, that is VERTEXNIM on a circuit. Again, we only consider positions with no 1 occurring as initial positions. We get a result similar to the one in the normal version.

**Theorem 4.14** *Let  $(C_n, w, v_1), n \geq 3$  be an instance of VERTEXNIM with  $C_n$  the circuit of length  $n$  and  $w : V \rightarrow \mathbb{N}_{>1}$ .*

- *If  $n$  is odd, then  $(C_n, w, v_1)$  is an  $\mathcal{N}$ -position.*
- *If  $n$  is even, then  $(C_n, w, v_1)$  is an  $\mathcal{N}$ -position if and only if the smallest index of a vertex of minimum weight, that is  $\min_{1 \leq i \leq n} \{w(v_i)\}$ , is even.*

**Proof.**

- *Case (1)* If  $n$  is odd, then the first player can apply the following strategy to win: first, she plays  $w(v_1) \rightarrow 1$ . Then for all  $1 \leq i < \frac{n-1}{2}$ : if the second player empties  $v_{2i}$ , then the first player also empties the following vertex  $v_{2i+1}$ . Otherwise, she plays  $w(v_{2i+1}) \rightarrow 1$ . This time, the strategy is not different for the last two vertices of  $C_n$ . As  $w(v_1) = 1$ , the second player is now forced to empty  $v_1$ . Since an odd number of vertices was deleted since then, we now have an even circuit to play on. It now suffices for the first player to empty all the vertices on the second run. Indeed, the second player is also forced to set each weight to 0 since he has to play on vertices satisfying  $w = 1$ . Since the circuit is even, the first player is guaranteed to leave the last move to the second player.
- *Case (2)* If  $n$  is even, we claim that who must play the first vertex of minimum weight will lose the game. The winning strategy of the other player consists in decreasing by 1 the weight of each vertex at their turn. Assume that  $\min_{1 \leq i \leq n} \{\operatorname{argmin} w(v_i)\}$  is odd. If the strategy of the second player always consists in moving  $w(v_i) \rightarrow w(v_i) - 1$ , then the first player will be the first to set a weight to 0 or 1. If she sets the weight of a vertex to 0, then the second player now faces an instance  $(C'_{n-1}, w')$  with  $w' : V' \rightarrow \mathbb{N}_{>1}$ , which is winning according to the previous item. If she sets the weight of a vertex to 1, then the second player will empty the following vertex, leaving to the first player a position  $(C'_{n-1} = (v'_1, v'_2, \dots, v'_{N-1}), w')$  with  $w' : V' \rightarrow \mathbb{N}_{>1}$  except on  $w'(v'_{n-1}) = 1$ . This position corresponds to the one of the previous item after the first move, and is thus losing. A similar argument shows that the first player has a winning strategy if  $\min_{1 \leq i \leq n} \{\operatorname{argmin} w(v_i)\}$  is even.

□

The reader would have seen the similarity between the proofs of normal version and misère version. The following results are even more similar in their proof, this is why we do not recall the proofs in their entirety.

We now state how to find the misère outcome of a VERTEXNIM position on any undirected graph.

**Theorem 4.15** *Let  $(G, w, u)$  be an instance of VERTEXNIM, where  $G$  is an undirected graph. Deciding whether the misère outcome of  $(G, w, u)$  is  $\mathcal{P}$  or  $\mathcal{N}$  can be done in  $O(|V(G)||E(G)|)$  time.*

**Proof.** If all vertices have weight 1, then  $(G, w, u)$  is an  $\mathcal{N}$ -position if and only if  $|V(G)|$  is even since it reduces to the misère version of “She loves move, she loves me not”. Otherwise, we can use the same proof as the one



of Theorem 2.9 to see that  $(G, w, u)$  is  $\mathcal{N}$  in the misère version if and only if it is  $\mathcal{N}$  in the normal version.  $\square$

Finally, we state how to find the misère outcome of a VERTEXNIM position on any directed graph with a self loop on each vertex.

**Theorem 4.16** *Let  $(G, w, u)$  be an instance of VERTEXNIM, where  $G$  is strongly connected, with a loop on each vertex. Deciding whether the misère outcome of  $(G, w, u)$  is  $\mathcal{P}$  or  $\mathcal{N}$  can be done in time  $O(|V(G)||E(G)|)$ .*

**Proof.** If all vertices have weight 1, then  $(G, w, u)$  is an  $\mathcal{N}$  position if and only if  $|V(G)|$  is even since it reduces to the misère version of “She loves move, she loves me not”. Otherwise, we can use the same proof as the one of Theorem 2.7 to see that  $(G, w, u)$  is  $\mathcal{N}$  in the misère version if and only if it is  $\mathcal{N}$  in the normal version.  $\square$

### 4.1.3 TIMBER

In TIMBER, going to misère is already harder. Though we can still reduce the game to an oriented forest, which happens to be the same forest as for normal play, we can only give a polynomial algorithm for finding the misère outcome of an oriented path.

**Theorem 4.17** *Let  $G$  be a directed graph seen as a TIMBER position such that there exist a set  $S$  of vertices that forms a 2-edge-connected component of  $G$ , and  $x, y$  two vertices not belonging to  $S$ . Let  $G'$  be the directed graph with vertex set*

$$V(G') = (V(G) \setminus S) \cup \{x, y\}$$

and arc set

$$\begin{aligned} A(G') = & (A(G) \setminus \{(u, v) \mid \{u, v\} \cap S \neq \emptyset\}) \\ & \cup \{(u, x) \mid u \in (V(G) \setminus S), \exists v \in S, (u, v) \in A(G)\} \\ & \cup \{(x, u) \mid u \in (V(G) \setminus S), \exists v \in S, (v, u) \in A(G)\} \\ & \cup \{(y, x)\}. \end{aligned}$$

Then  $G =^- G'$ .

**Proof.** The proof is identical to the proof of Theorem 2.14 as we never used the fact we were under the normal convention.  $\square$

As in normal play, we get the following corollary.

**Corollary 4.18** *For any directed graph  $G$ , there exists an oriented forest  $F_G$  such that  $G =^+ F_G$  and  $G =^- F_G$ . Moreover,  $F_G$  is computable in quadratic time.*

The following proposition remains true as well for the same reason.

**Proposition 4.19** *Let  $T$  be an oriented tree such that there exist three sets of vertices  $\{u_i\}_{0 \leq i \leq k}$ ,  $\{v_i\}_{0 \leq i \leq k}$ ,  $\{w_i\}_{0 \leq i \leq \ell} \subset V(G)$  such that:*

1.  $(\{(u_{i-1}, u_i)\}_{1 \leq i \leq k} \cup \{(v_{i-1}, v_i)\}_{1 \leq i \leq k} \cup \{(w_{i-1}, w_i)\}_{1 \leq i \leq \ell}) \subset A(G)$ ,
2.  $(u_k, w_0), (v_k, w_\ell) \in A(G)$ ,
3.  $u_0$  and  $v_0$  have in-degree 0 and out-degree 1,
4. for all  $1 \leq i \leq k$ ,  $u_k$  and  $v_k$  have in-degree 1 and out-degree 1.

Let  $T'$  be the oriented tree with vertex set

$$V(T') = V(T) \setminus \{v_i\}_{0 \leq i \leq k}$$

and arc set

$$A(T') = A(T) \setminus (\{(v_{i-1}, v_i)\}_{1 \leq i \leq k} \cup \{(v_k, w_\ell)\}).$$

Then  $T =^- T'$ .

**Proof.** The proof is identical to the proof of Proposition 2.17 as we never used the fact we were under the normal convention.  $\square$

On paths, we can use the peak representation as defined in Section 2.2, but we can also code the problem with a word:  $L$  would represent an arc directed leftward while  $R$  would represent an arc directed rightward. As in Sections 2.2 and 3.1, we can see it as a row of dominoes that would topple everything in one direction when chosen, where chosen dominoes can only be toppled face up. The position is read from left to right.

Given the alphabet  $\{L, R\}$ , for a word  $w$ , let  $|w|_L$  be the number of  $L$ 's in  $w$ ,  $|w|_R$  the number of  $R$ 's in  $w$  and  $w_{[i,j]}$  the subword  $w_i w_{i+1} \cdots w_j$ . Let  $WP$  be the set of words  $w$  such that for any  $i$ ,  $|w_{[0,i]}|_L \geq |w_{[0,i]}|_R$  and  $|w|_L = |w|_R$ ; and  $SWP$  be the set of words  $w$  such that  $w \in WP$  and  $\forall w_1, w_2 \in WP$ ,  $w \neq w_1 L R w_2$ . We define  $X = (SWP \setminus \{\emptyset\}) \cup \{Rw \mid w \in SWP\} \cup \{wL \mid w \in SWP\} \cup \{RwL \mid w \in SWP\}$ . We note  $\tilde{w}$  the word obtained from  $w$  after removing the first character if it is an  $R$  and the last one if it is an  $L$ .

The reader would have recognised  $WP$  as the set of normal  $\mathcal{P}$ -positions of TIMBER on a path. We now prove that misère  $\mathcal{P}$ -positions of TIMBER on a path are those belonging to  $X$ , that is all words  $w$  such that  $\tilde{w} \in SWP$  but the empty word.

**Theorem 4.20** *In misère play, the  $\mathcal{P}$ -positions of TIMBER on a path are exactly those which correspond to words of  $X$ .*

**Proof.** Let  $w \in X$  be a position. Assume  $w \in (SWP \setminus \{\emptyset\})$ . From the normal play analysis, we know that the first player cannot move to a position in  $SWP \subset WP$ . Assume the first player can move to a position  $Rw_0$  with  $w_0 \in SWP$ . Then it follows that  $w = w_1LRw_0$  for some  $w_1$ . As  $w, w_0 \in WP$  then  $w_1 \in WP$ , which is not possible since  $w \in SWP$ . Similarly, we can prove the first player has no move to a position of the form  $w_0L$  or  $Rw_0L$  with  $w_0 \in SWP$ . Similarly, we can prove the first player has no move to a position in  $X$  from a position in  $X$ .

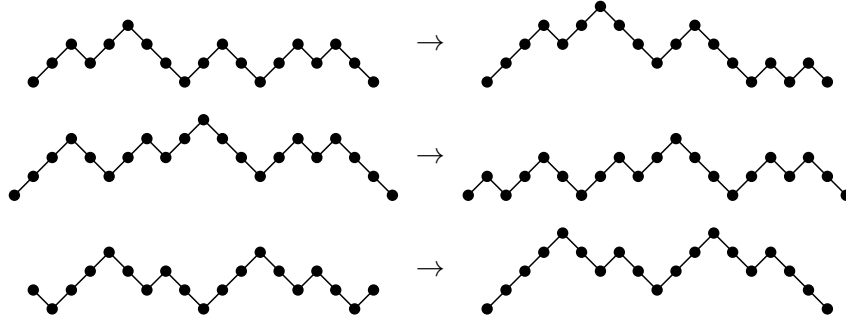
Let  $w \notin X \cup \{\emptyset\}$ . Assume  $w \in WP$ . Then there exist  $w_1, w_2 \in WP$  such that  $w = w_1LRw_2$ , and we can choose them such that  $w_2 \in SWP$ . From  $w$ , the first player can move to  $Rw_2 \in X$ . Similarly, we can prove the first player has a move to a position in  $X$  from a position in  $(\{Rw \mid w \in WP\} \cup \{wL \mid w \in WP\} \cup \{RwL \mid w \in WP\}) \setminus X$ .

Now assume  $w_{[0,1]} = RR$ . The first player can move to  $R \in X$ .

Now assume  $w$  is none of the above forms. Thus  $\tilde{w}$  starts with an  $L$  and ends with an  $R$ , and is not in  $WP$ , so the first player has a move from  $\tilde{w}$  to a position  $w_0 \in WP \setminus \{\emptyset\}$ . Without loss of generality, we can assume it is by toppling a domino leftward. If  $w_0 \in SWP$ , the same move from  $w$  leaves the position  $w_0 \in X$  or  $w_0L \in X$ . Otherwise, there exist  $w_1, w_2 \in WP$  such that  $w_0 = w_1LRw_2$  and we can choose  $w_2 \in SWP$ . The first player can then move from  $w$  to  $Rw_2 \in X$  or  $Rw_2L \in X$ .  $\square$

$SWP$  is the set of TIMBER positions whose peak representations are Dyck paths without peaks at height 1. The number of such Dyck paths of length  $2n$  is the  $n^{\text{th}}$  Fine number  $F_n = \frac{1}{2} \sum_{i=0}^{-2} (-1)^i c_{n-i} \left(\frac{1}{2}\right)^i$ , where  $c_k = \frac{(2k)!}{k!(k+1)!}$  is the  $k^{\text{th}}$  Catalan number [31]. This gives us the number of TIMBER misère  $\mathcal{P}$ -positions on paths of length  $n$ : there are no TIMBER misère  $\mathcal{P}$ -positions on paths of length 0; there are  $2F_n = \sum_{i=0}^{-2} (-1)^i c_{n-i} \left(\frac{1}{2}\right)^i$  TIMBER misère  $\mathcal{P}$ -positions on paths of length  $2n + 1$ ; there are  $F_n + F_{n-1}$  TIMBER misère  $\mathcal{P}$ -positions on paths of length  $2n$ .

That last number is also the number of Dyck paths of length  $2n$  with no peak at height 2 before the first time the path returns at height 0. We can define a bijection between TIMBER misère  $\mathcal{P}$ -positions on paths of length  $2n$  and Dyck paths of length  $2n$  with no peak at height 2 before the first time the path returns at height 0 as follows (using their word representation): if the word can be written  $w_1Lw_2R$  with both  $w_1$  and  $w_2$  representing Dyck paths (note that  $w_1$  might be empty, but not  $w_2$ ), its image is  $Lw_1Rw_2$ . otherwise, the word can be written  $RwL$  with  $w$  representing a Dyck path, and its image is  $LwR$ . Figure 4.5 gives examples of the bijection, using the peak representation. The TIMBER misère  $\mathcal{P}$ -positions are on the left, and at their right are their images through the bijection.



**Figure 4.5:** TIMBER misère  $\mathcal{P}$ -positions and their images, Dyck paths with no peak at height 2 before the first return to 0

#### 4.1.4 TIMBUSH

For TIMBUSH, we still reduce the directed graph to an oriented forest, but our knowledge stops there. Even on an oriented path, finding the misère outcome seems challenging.

**Theorem 4.21** *Let  $G$  be a directed graph seen as a TIMBUSH position such that there exist a set  $S$  of vertices that forms a 2-edge-connected component of  $G$ , and  $x, y$  two vertices not belonging to  $S$ . Let  $G'$  be the directed graph with vertex set*

$$V(G') = (V(G) \setminus S) \cup \{x, y\}$$

*and arc set*

$$\begin{aligned} A(G') = & (A(G) \setminus \{(u, v) \mid \{u, v\} \cap S \neq \emptyset\}) \\ & \cup \{(u, x) \mid u \in (V(G) \setminus S), \exists v \in S, (u, v) \in A(G)\} \\ & \cup \{(x, u) \mid u \in (V(G) \setminus S), \exists v \in S, (v, u) \in A(G)\} \\ & \cup \{(y, x)\}, \end{aligned}$$

*keeping the same colours, where the colour of  $(y, x)$  is grey if the arcs in  $S$  yields different colours, and of the unique colour of arcs in  $S$  otherwise. Then  $G =^- G'$ .*

**Proof.** The proof is identical to the proof of Theorem 3.4 as we never used the fact we were under the normal convention.  $\square$

As in normal play, we get the following corollary.

**Corollary 4.22** *For any directed graph  $G$ , there exists an oriented forest  $F_G$  such that  $G =^+ F_G$  and  $G =^- F_G$  and  $F_G$  is computable in quadratic time.*

The following proposition is true as well, for the same reason.

**Proposition 4.23** *Let  $T$  be an oriented tree such that there exist three sets of vertices  $\{u_i\}_{0 \leq i \leq k}, \{v_i\}_{0 \leq i \leq k}, \{w_i\}_{0 \leq i \leq \ell} \subset V(G)$  such that:*

1.  $(\{(u_{i-1}, u_i)\}_{1 \leq i \leq k} \cup \{(v_{i-1}, v_i)\}_{1 \leq i \leq k} \cup \{(w_{i-1}, w_i)\}_{1 \leq i \leq \ell}) \subset A(G)$ ,
2.  $\{(u_k, w_0), (v_k, w_\ell)\} \subset A(G)$ ,
3.  $u_0$  and  $v_0$  have in-degree 0 and out-degree 1,
4. for all  $1 \leq i \leq k$ ,  $u_k$  and  $v_k$  have in-degree 1 and out-degree 1,
5. for all  $1 \leq i \leq k$ ,  $(u_{k-1}, u_k)$  and  $(v_{k-1}, v_k)$  have the same colour.
6.  $(u_k, w_0)$  and  $(v_k, w_\ell)$  have the same colour.

Let  $T'$  be the oriented tree with vertex set

$$V(T') = V(T) \setminus \{v_i\}_{0 \leq i \leq k}$$

and arc set

$$A(T') = A(T) \setminus (\{(v_{i-1}, v_i)\}_{1 \leq i \leq k} \cup \{(v_k, w_\ell)\}),$$

keeping the same colours, apart from  $(u_k, w_0)$  which becomes grey when  $(u_k, w_0)$  and  $(v_k, w_\ell)$  had different colours in  $T$ . Then  $T =^- T'$ .

**Proof.** The proof is identical to the proof of Proposition 3.7 as we never used the fact we were under the normal convention.  $\square$

#### 4.1.5 TOPPLING DOMINOES

In TOPPLING DOMINOES, the misère outcome of a single row is easy to determine, but finding equivalence classes in the general case has eluded us for now.

**Proposition 4.24** *The misère outcome of a TOPPLING DOMINOES position on a single row is determined by its end dominoes and the dominoes right next to them. For any string  $x$ ,*

- $L, ERE, LxL, ERxL, LxRE, ERxRE \in \mathcal{R}^-$ ,
- $R, ELE, RxR, ELxR, RxLE, ELxLE \in \mathcal{L}^-$ ,
- $E \in \mathcal{P}^-$ ,
- $\emptyset, EL, LE, ER, RE, LxR, RxL, EEx, xEE, ELxL, LxLE, ERxR, RxRE, ELxRE, ERxLE \in \mathcal{N}$ .

In particular, we note that there is only one TOPPLING DOMINOES position on a single row that is a misère  $\mathcal{P}$ -position.

Nevertheless, when allowing a game on several rows, the set of TOPPLING DOMINOES misère  $\mathcal{P}$ -positions is infinite, as all NIM positions are equal to a TOPPLING DOMINOES position using only grey dominoes.

However, if we restrict ourselves to black and white dominoes (excluding grey dominoes), we prove that no position is a misère  $\mathcal{P}$ -position, no matter the number of rows of the position. We actually fully characterise the outcome of any set of rows of black and white dominoes.

Before stating the theorem, we define a pair of functions on sets of rows of dominoes. For any set of rows  $G$  of black and white dominoes, we define  $l_{td}(G)$  the number of rows of dominoes in  $G$  that start and end with a black domino. Similarly, we define  $r_{td}(G)$  the number of rows of dominoes in  $G$  that start and end with a white domino.

**Theorem 4.25** *Let  $G$  be a set of rows of black and white dominoes. Then*

$$o^-(G) = \begin{cases} \mathcal{N}^- & \text{if } l_{td}(G) = r_{td}(G) \\ \mathcal{L}^- & \text{if } l_{td}(G) < r_{td}(G) \\ \mathcal{R}^- & \text{if } l_{td}(G) > r_{td}(G) \end{cases}$$

**Proof.** We prove the result by induction on the number of dominoes in  $G$ . If there is no domino, the outcome is trivially  $\mathcal{N}$ .

Assume now there is at least one domino. Assume first  $l_{td}(G) = r_{td}(G)$ . If  $l_{td}(G) > 0$ , Left can play a domino on the edge of a row that starts and ends with a black domino to remove it from the game, moving to a position  $G'$  such that  $l_{td}(G') = l_{td}(G) - 1 = r_{td}(G) - 1 = r_{td}(G') - 1$ , which is an  $\mathcal{L}$ -position by induction. Otherwise, we may assume without loss of generality that there is a row that starts with a black domino and ends with a white domino. Left can choose the rightmost black domino of that row and topple it leftward, moving to a position  $G'$  such that  $r_{td}(G') = r_{td}(G) + 1 = l_{td}(G) + 1 = l_{td}(G') + 1$ , which is an  $\mathcal{L}$ -position by induction. A similar argument on Right moves shows that  $G$  is an  $\mathcal{N}$ -position. Assume now  $l_{td}(G) < r_{td}(G)$ . Then there exists a row that starts and ends with a white domino. If that row contains a black domino, Left can choose the rightmost black domino of that row and topple it leftward, moving to a position  $G'$  such that  $r_{td}(G') = r_{td}(G) > l_{td}(G) = l_{td}(G')$ , which is an  $\mathcal{L}$ -position by induction. Otherwise, that is if all rows that start and end with a white domino contain no black domino, either she has no move and wins, or she can choose a black domino at an end of a row and topple it toward the other ends, moving to a position  $G'$  such that  $r_{td}(G') = r_{td}(G) > l_{td}(G) \geq l_{td}(G')$ , which is an  $\mathcal{L}$ -position by induction. Whatever Right does, he can only change the status of one row, and only change one of the end dominoes of this row or empty it, moving to a position  $G'$  where  $r_{td}(G') - l_{td}(G') = r_{td}(G) - l_{td}(G)$  or  $r_{td}(G') - l_{td}(G') = r_{td}(G) - l_{td}(G) - 1$ , which is either an  $\mathcal{L}$ -position or an  $\mathcal{N}$ -position by induction. Hence  $G$  is an  $\mathcal{L}$ -position.

The case when  $l_{td}(G) > r_{td}(G)$  is similar. □

This implies that any row of black and white dominoes starting and ending with a black domino is equivalent to a single black domino modulo the

universe of *LR-TOPPLING DOMINOES* positions. Also any row of black and white dominoes starting and ending with a white domino is equivalent to a single white domino modulo the universe of *LR-TOPPLING DOMINOES* positions and any row of black and white dominoes starting and ending with dominoes of different colours is equivalent to an empty row modulo the universe of *LR-TOPPLING DOMINOES* positions. Note that this equivalence is not true in the universe of all *TOPPLING DOMINOES* positions. For example, the position  $LL$  and  $L$  are not equivalent in this universe:  $L + E + E$  is a misère  $\mathcal{P}$ -position, while  $LL + E + E$  is a misère  $\mathcal{L}$ -position.

This equivalence allows us to completely describe the misère monoid of *LR-TOPPLING DOMINOES* positions, which we present in Theorem 4.26.

**Theorem 4.26** *Under the mapping*

$$G \mapsto \alpha^{l_{td}(G) - r_{td}(G)},$$

*the misère monoid of LR-TOPPLING DOMINOES positions is*

$$\mathcal{M}_{\mathbb{Z}} = \langle 1, \alpha, \alpha^{-1} \mid \alpha \cdot \alpha^{-1} = 1 \rangle \cong (\mathbb{Z}, +)$$

*with outcome partition*

$$\mathcal{N}^- = \{1\}, \mathcal{L}^- = \{\alpha^{-n} \mid n \in \mathbb{N}^*\}, \mathcal{R}^- = \{\alpha^n \mid n \in \mathbb{N}^*\}$$

*and total ordering*

$$\alpha^n > \alpha^m \Leftrightarrow n < m.$$

This result is quite surprising as in general, the misère version of a game is harder than its normal version, and *LR-TOPPLING DOMINOES* has not been solved under normal convention. From what we saw in Section 3.2 and results from [17], the structure is richer in normal play than in misère play.

#### 4.1.6 COL

Notice first that all *COL* positions are dead-ending.

On *COL*, we give the outcome of some classes of graphs, and even equivalence class modulo the dead-ending universe for some of them.

We use the same notation as in Section 3.3.

First, we present some features participating in explaining why misère play seems harder than normal play for the game of *COL*.

Adding a black vertex or reserving a vertex for Left would seem to be an advantage for Right in misère play. Unfortunately, that intuition is false:

$$o^-(o + o) = \mathcal{N}; o^-(oBo) = \mathcal{L}$$

$$o^-(ooo) = \mathcal{N}; o^-(oBo) = \mathcal{L}$$

A theorem such as Theorem 3.51 cannot be stated: the second player would never use such strategy as they would be sure to lose this way, and the first player cannot force such a choice.

Now we are back with finding misère outcomes of positions.

We start with paths. The following lemma gives the equivalence class modulo the dead-ending universe of paths whose end vertices are black or white and all internal vertices are grey.

**Lemma 4.27**

1. for any non-negative integer  $n$ ,  $Bo^nB \equiv_{\mathcal{E}}^- B$ .
2. for any non-negative integer  $n$ ,  $Bo^nW \equiv_{\mathcal{E}}^- \emptyset$ .

**Proof.** We show simultaneously that  $G + B$  and  $G + Bo^nB$  have the same outcome, as well as  $G$  and  $G + Bo^nW$ , by induction on  $n \in \mathbb{N}$  and the order of  $G \in \mathcal{E}$ .

By playing on any vertex of  $Bo^nB$ , Left goes to a game which is equivalent to  $\emptyset$  modulo  $\mathcal{E}$ , either by induction or because it is  $\emptyset$ . By playing on any vertex of  $Bo^nB$ , Right goes to a game which is equivalent to  $B + B$  modulo  $\mathcal{E}$  by induction or because it is  $B + B$ . By playing on any vertex of  $Bo^nW$ , Left goes to a game which is equivalent to  $W$  modulo  $\mathcal{E}$  by induction or because it is  $W$ . By playing on any vertex of  $Bo^nW$ , Right goes to a game which is equivalent to  $B$  modulo  $\mathcal{E}$  by induction or because it is  $B$ .

Let  $G$  be a dead-ending game such that Left wins  $G + B$  playing first (or second). On  $G + Bo^nB$ , Left can follow her  $G + B$  strategy, unless Right plays from some  $G' + Bo^nB$  to  $G' + (Bo^nB)^R$  or the strategy recommends her to play from some  $G' + B$  to  $G'$ . In the former case, Right has just moved  $Bo^nB$  to a game equivalent to  $B + B$  modulo  $\mathcal{E}$  and she can put the game on  $G' + B$  which she wins a priori. In the latter case, she can move from  $G' + Bo^nB$  to a game equivalent to  $G'$  modulo  $\mathcal{E}$  and continue as if she had just moved from  $B$  to  $\emptyset$ .

Let  $G$  be a dead-ending game such that Right wins  $G + B$  playing first (or second). On  $G + Bo^nB$ , Right can follow his  $G + B$  strategy, unless Left plays from some  $G' + Bo^nB$  to  $G' + (Bo^nB)^L$  or he has no more move. In the former case, Left has just moved  $Bo^nB$  to a game equivalent to  $\emptyset$  modulo  $\mathcal{E}$  and he can assume she had just moved from  $B$  to  $\emptyset$ . In the latter case, he can move from  $G' + Bo^nB$  to a game equivalent to  $G' + B + B$  modulo  $\mathcal{E}$  where he has no move and wins as he will never get any.

Hence,  $Bo^nB \equiv_{\mathcal{E}}^- B$ .

Let  $G$  be a dead-ending game such that Left wins  $G$  playing first (or second). On  $G + Bo^nW$ , Left can follow her  $G$  strategy, unless Right plays from some  $G' + Bo^nW$  to  $G' + (Bo^nW)^R$  or she has no more move. In the former case, Right has just moved  $Bo^nW$  to a game equivalent to  $B$  modulo  $\mathcal{E}$  and she can put the game on  $G'$  which she wins a priori. In the latter case, she can move from  $G' + Bo^nW$  to a game equivalent to  $G' + W$  modulo  $\mathcal{E}$  where he



has no move and wins as she will never get any.

A similar argument would show that when White has a winning strategy on  $G$ , he has one on  $G + Bo^nW$ .

Hence,  $Bo^nW \equiv_{\mathcal{E}}^- \emptyset$ .  $\square$

This implies the following result on cycles, where all moves are equivalent, leading to a position we just analysed.

**Theorem 4.28** *For any integer  $n$  greater than or equal to 3, we have  $C_n \equiv_{\mathcal{E}}^- \emptyset$ .*

**Proof.** The only Left option of  $C_n$  is  $Wo^{n-3}W$ , which is equivalent to  $W$  modulo  $\mathcal{E}$  and the only Right option of  $C_n$  is  $Bo^{n-3}B$ , which is equivalent to  $B$  modulo  $\mathcal{E}$ . Hence  $C_n$  is equivalent to  $\{W|B\} = BW$  modulo  $\mathcal{E}$ , and as  $BW$  is equivalent to  $\emptyset$  modulo  $\mathcal{E}$ ,  $C_n$  is as well.  $\square$

We now look at sums of paths as it gives us the misère outcome of any grey path, and helps find the misère outcome of bigger positions.

**Lemma 4.29**

1. *For any non-negative integer  $l$ , any non-negative integers  $n_i$  ( $i \in \llbracket 1; l \rrbracket$ ), we have  $\sum_{i=1}^l Wo^{n_i} \in \mathcal{N}^- \cup \mathcal{L}^-$ , that is Left has a winning strategy if she plays first.*
2. *For any non-negative integer  $l$ , any non-negative integers  $n_i$  ( $i \in \llbracket 1; l \rrbracket$ ), we have  $(W + \sum_{i=1}^l Wo^{n_i}) \in L^-$ , that is Left has a winning strategy whoever plays first.*

**Proof.** We show the results simultaneously by induction on  $n = \sum_{i=1}^l n_i$ .

If  $n = 0$ , Left has no move on either  $\sum_{i=1}^l Wo^{n_i}$  or  $(W + \sum_{i=1}^l Wo^{n_i})$ , and as Right has at least one move on  $(W + \sum_{i=1}^l Wo^{n_i})$ , the results hold.

Assume  $n \geq 1$ . Without loss of generality, we may assume  $n_l \geq 1$ . If Left plays on the non-reserved leaf of  $Wo^{n_l}$  in  $\sum_{i=1}^l Wo^{n_i}$ , it becomes equivalent to  $W + \sum_{i=1}^{l-1} Wo^{n_i}$  modulo  $\mathcal{E}$ , where Left has a winning strategy by induction. Hence Left has a winning strategy on  $\sum_{i=1}^l Wo^{n_i}$  if she plays first.

We notice  $(W + \sum_{i=1}^l Wo^{n_i}) = \sum_{i=0}^l Wo^{n_i}$  with  $n_0 = 0$ , so if Left is the first player on  $(W + \sum_{i=1}^l Wo^{n_i})$ , then she has a winning strategy from 1. Assume Right is the first player on  $(W + \sum_{i=1}^l Wo^{n_i})$ . If Right plays on  $W$ , then the game becomes  $(\sum_{i=1}^l Wo^{n_i})$  where we just saw Left has a winning strategy playing first. Otherwise, we may assume Right plays on a vertex of  $Wo^{n_i}$  without loss of generality. If this vertex is the non-reserved leaf, then the game becomes equivalent to  $(W + \sum_{i=1}^{l-1} Wo^{n_i})$  modulo  $\mathcal{E}$  where Left has a winning strategy by induction. Otherwise, Left can answer on this leaf, leaving a game equivalent to  $(W + \sum_{i=1}^{l-1} Wo^{n_i})$  modulo  $\mathcal{E}$  where she has a winning strategy by induction. Hence Left has a winning strategy on  $(W + \sum_{i=1}^l Wo^{n_i})$ .  $\square$

As expected, we can use this result to find the outcome of any grey path.

**Theorem 4.30** *For any integer  $n$  greater than or equal to 2, we have  $o^n \in \mathcal{N}^-$  that is the first player has a winning strategy.*

**Proof.**  $o^2$  and  $BW$  have the same options, so are equivalent modulo  $\mathcal{E}$ , hence  $o^2$  is equivalent to  $\emptyset$  modulo  $\mathcal{E}$ .

Assume  $n \geq 3$ . Without loss of generality, we can assume that Left is the first player. By playing on a vertex next to a leaf, Left leaves the game as  $W + Wo^{n-3}$ , where she has a winning strategy by Lemma 4.29. Hence the first player has a winning strategy on  $o^n$ .  $\square$

We now find the outcome of any tree with at most one vertex having degree at least 3. Before that, we need to find the outcome of positions that players might reach from these trees. We do not consider all such positions as we did in normal play, since we only need to consider positions that occur under one player's winning strategy. We look again at sums of path, where we refine the previous results. First, we add a path having exactly one black leaf and all other vertices being grey to a sum of paths considered in Lemma 4.29, assuming there are at least two single white vertices.

**Lemma 4.31** *For any non-negative integer  $l$ , any non-negative integers  $n_i$  ( $i \in \llbracket 1; l+1 \rrbracket$ ), we have  $(W + W + Bo^{n_{l+1}} + \sum_{i=1}^l Wo^{n_i}) \in \mathcal{L}^-$ , that is Left has a winning strategy whoever plays first.*

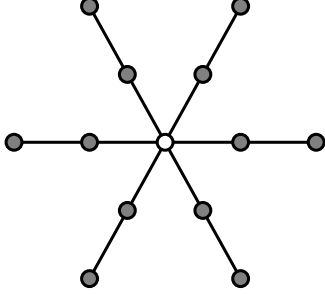
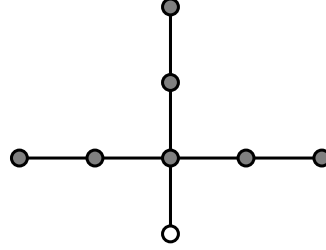
**Proof.** We show the result by induction on  $\sum_{i=1}^{l+1} n_i$ . If Left is the first player, she can play on the vertex reserved for her, leaving  $(W + W + Wo^{n_{l+1}-1} + \sum_{i=1}^l Wo^{n_i})$  where she has a winning strategy by Lemma 4.29.

Assume now Right is the first player. If he plays on a  $W$ , then Left can play on the vertex reserved for her, leaving  $(W + Wo^{n_{l+1}-1} + \sum_{i=1}^l Wo^{n_i})$  where she has a winning strategy by Lemma 4.29. If he plays on a vertex of  $Bo^{n_{l+1}}$ , Left can play on the vertex reserved for her, leaving a game equivalent to  $(W + W + Bo^{n_{l+1}} + \sum_{i=1}^l Wo^{n_i})$  modulo  $\mathcal{E}$ , where she has a winning strategy by induction. Otherwise, we can assume without loss of generality that Right plays on a vertex of  $Wo^{n_l}$  and that  $n_l \geq 1$ . If it is on the non-reserved leaf, the game becomes equivalent to  $(W + W + Bo^{n_{l+1}} + \sum_{i=1}^{l-1} Wo^{n_i})$  modulo  $\mathcal{E}$ , where Left has a winning strategy by induction. Otherwise, Left can answer on this leaf, leaving a game equivalent to  $(W + W + Bo^{n_{l+1}} + \sum_{i=1}^{l-1} Wo^{n_i})$  modulo  $\mathcal{E}$ , where she has a winning strategy by induction.

Hence Left has a winning strategy on  $(W + W + Bo^{n_{l+1}} + \sum_{i=1}^l Wo^{n_i})$ .  $\square$

We are now back to paths where exactly one leaf is white and all other vertices are grey, but we add the extra condition that at least two of these paths each contain at least three vertices.

**Lemma 4.32** *For any non-negative integer  $k$ , any integer  $l$  greater than or equal to 2, any integers  $n_i$  greater than or equal to 2 ( $i \in \llbracket 1; l \rrbracket$ ), we have  $(\sum_{j=1}^k Wo + \sum_{i=1}^l Wo^{n_i}) \in \mathcal{L}^-$ , that is Left has a winning strategy.*

Figure 4.6: The tree  $Si_6^W$ Figure 4.7: The tree  $WSi_3^o$ 

**Proof.** We show the result by induction on  $k$ . If Left is the first player, then she has a winning strategy by Lemma 4.29.

Assume now Right is the first player. If he plays on the reserved vertex of some  $Wo$ , Left can answer on the other vertex, leaving the game as  $(\sum_{j=1}^{k-1}Wo + \sum_{i=1}^l Wo^{n_i})$ , where she has a winning strategy by induction. If he plays on the non-reserved vertex of some  $Wo$ , the game becomes  $(\sum_{j=1}^{k-1}Wo + \sum_{i=1}^l Wo^{n_i})$ , where Left has a winning strategy by induction. Otherwise, we can assume without loss of generality that Right plays on a vertex of  $Wo^{n_i}$ . Left can answer on the vertex next to the non-reserved end of  $Wo^{n_i-1}$ , leaving a graph equivalent modulo  $\mathcal{E}$  to either  $(W + W + \sum_{j=1}^k Wo + \sum_{i=1}^{l-2} Wo^{n_i})$ , where she has a winning strategy by Lemma 4.29, or  $(W + W + Bo^m + \sum_{j=1}^k Wo + \sum_{i=1}^{l-2} Wo^{n_i})$  for some  $m \leq n_l$ , where she has a winning strategy by Lemma 4.31. Hence, Left has a winning strategy on  $(\sum_{j=1}^k Wo + \sum_{i=1}^l Wo^{n_i})$ .  $\square$

We now introduce some more notation, that we use in the following:

- (i)  $Si_n^c$  is the intersection graph of a star with  $n$  leaves, that is the tree with exactly one vertex of degree at least 3 and  $n$  leaves all at distance exactly 2 from this vertex, such that the center, that is the vertex of degree  $n$ , is labelled  $c$  and all other vertices are labelled  $o$ .
- (ii)  $c_1 Si_n^{c_2}$  is the intersection graph of a star with  $n$  leaves, such that the center is labelled  $c_2$ , to which we add a vertex labelled  $c_1$  that we link to the center, and all other vertices are labelled  $o$ .

**Example 4.33** Figure 4.6 is the coloured graph  $Si_6^W$ . All its vertices are grey but the center, which is white. Figure 4.7 is the coloured graph  $WSi_3^o$ . All its vertices are grey but the leaf at distance 1 from the center, which is white.

We now find the outcome, nay the equivalent class, of these positions we just introduced, starting with the equivalent class of  $Si_n^W$ .

**Lemma 4.34** *For any integer  $n$  greater than or equal to 2, we have  $Si_n^W \equiv_{\mathcal{E}}^- \emptyset$ .*

**Proof.** Let  $G$  be a dead-ending game that Left wins playing first (or second). On  $G + Si_n^W$ , Left can follow her  $G$  strategy, unless Right plays from some  $G' + Si_n^W$  to  $G' + (Si_n^W)^R$  or she has no more moves. In the former case, there are three cases. If Right plays on a leaf of  $Si_n^W$ , Left can answer on the other leaf if  $n = 2$ , leaving a game equivalent to  $G$  modulo  $\mathcal{E}$ , where she has a winning strategy if she plays second, or on the vertex next to the one Right just played on otherwise, leaving the game as  $G + Si_{n-1}^W$  where she has a winning strategy if she plays second by induction. If Right plays on a non-leaf non-reserved vertex of  $Si_n^W$ , Left can answer on the leaf next to it, leaving a game equivalent to  $G$  modulo  $\mathcal{E}$ , where she has a winning strategy if she plays second. If Right plays on the reserved vertex of  $Si_n^W$ , Left can answer on a leaf, leaving the graph as  $G + \Sigma_{i=1}^{n-1}Bo \geq_{\mathcal{E}}^- G$  where she has a winning strategy if she plays second. In the latter case, she can move from  $G' + Si_n^W$  to a game equivalent to  $G' + W$  modulo  $\mathcal{E}$  by induction by playing on a non-leaf of  $Si_n^W$ , where she has no move and wins as she will never get any.

Let  $G$  be a dead-ending game that Right wins playing first (or second). On  $G + Si_n^W$ , Right can follow his  $G$  strategy, unless Left plays from some  $G' + Si_n^W$  to  $G' + (Si_n^W)^L$  or he has no more moves. In the former case, there are two cases. If Left plays on a leaf of  $Si_n^W$ , Right can answer on the vertex next to the one Left just played on, leaving a game equivalent to  $G'$  modulo  $\mathcal{E}$ , where he has a winning strategy if he plays second. If Left plays on a non-leaf non-reserved vertex of  $Si_n^W$ , Right can answer on a non-leaf non-reserved vertex of  $Si_n^W$ , leaving a game equivalent to  $G$  modulo  $\mathcal{E}$ , where he has a winning strategy if he plays second. In the latter case, he can move from  $G' + Si_n^W$  to a game equivalent to  $G' + B$  modulo  $\mathcal{E}$  by playing on a non-leaf of  $Si_n^W$ , where he has no move and wins as he will never get any. Hence,  $Si_n^W \equiv_{\mathcal{E}}^- \emptyset$ .  $\square$

We now give the outcome of  $WSi_n^o$ , which corresponds to a position where Left would have played on a leaf of  $Si_{n+1}^o$ .

**Lemma 4.35** *For any integer  $n$  greater than or equal to 2, we have  $WSi_n^o \in \mathcal{L}^-$ , that is Left has a winning strategy whoever plays first.*

**Proof.** If Left is the first player, she can play on the central vertex, leaving the game as  $W + \Sigma_{i=1}^n Wo$ , where she has a winning strategy by Lemma 4.29. Assume Right is the first player. If Right plays on the reserved vertex, the game becomes equivalent to  $\emptyset$  modulo  $\mathcal{E}$ , where Left has a winning strategy if she plays first. If Right plays on the central vertex, the game becomes  $\Sigma_{i=1}^n Bo \geq_{\mathcal{E}}^- \emptyset$ , where Left has a winning strategy if she plays first. If Right plays on any non-reserved leaf, Left can answer on the central vertex, leaving

the game as  $W + \sum_{i=1}^{n-1} Wo$ , where she has a winning strategy by Lemma 4.29. If Right plays on any other vertex, the game becomes either equivalent to  $\emptyset$  modulo  $\mathcal{E}$ , where Left has a winning strategy if she plays first, or, if  $n = 2$ ,  $B + WBoo$ , where Left can play on the non-reserved non-leaf vertex, leaving a game equivalent to  $W$  modulo  $\mathcal{E}$ , where she has a winning strategy. Hence, Left has a winning strategy on  $WSi_n^o$ .  $\square$

Now we sum these positions with paths and find the outcome of such sums, as they appear in the strategy we propose.

**Lemma 4.36** *For any integer  $n$  greater than or equal to 2 and any non-negative integer  $k$ , we have  $(Wo^k + WSi_n^o) \in \mathcal{L}^-$ , that is Left has a winning strategy.*

**Proof.** If Left is the first player, she can play on the central vertex, leaving the game as  $W + Wo^k + \sum_{i=1}^n Wo$ , where she has a winning strategy by Lemma 4.29.

Assume now Right is the first player. If Right plays on the non-reserved leaf on  $Wo^k$ , the game becomes equivalent to  $WSi_n^o$  modulo  $\mathcal{E}$ , where Left has a winning strategy by Lemma 4.35. If Right plays on any other vertex of  $Wo^k$ , Left can answer on that leaf, leaving a game equivalent to  $WSi_n^o$  modulo  $\mathcal{E}$ , where she has a winning strategy by Lemma 4.35. If Right plays on the reserved vertex of  $WSi_n^o$ , the game becomes equivalent to  $Wo^k$  modulo  $\mathcal{E}$ , where Left has a winning strategy if she plays first by Lemma 4.29. If Right plays on the central vertex of  $WSi_n^o$ , the game becomes  $Wo^k + \sum_{i=1}^n Bo \geq_{\mathcal{E}} Wo^k$ , where Left has a winning strategy if she plays first by Lemma 4.29. If Right plays on any non-reserved leaf of  $WSi_n^o$ , Left can answer on the central vertex, leaving the game as  $W + Wo^k + \sum_{i=1}^{n-1} Wo$ , where she has a winning strategy by Lemma 4.29. If Right plays on any other vertex, the game becomes either equivalent to  $Wo^k$  modulo  $\mathcal{E}$ , where Left has a winning strategy if she plays first by Lemma 4.29, or, if  $n = 2$ ,  $Wo^k + B + WBoo$ , where Left can play on the non-reserved non-leaf vertex, leaving a game equivalent to  $W + Wo^k$  modulo  $\mathcal{E}$ , where she has a winning strategy by Lemma 4.29.

Hence, Left has a winning strategy on  $(Wo^k + WSi_n^o)$ .  $\square$

We now state the theorem on the outcome of any grey subdivided star: all these positions are misère  $\mathcal{N}$ -positions.

**Theorem 4.37** *The first player has a winning strategy on any tree with exactly one vertex having degree at least three, with all vertices being coloured grey.*

**Proof.** We call  $v$  the vertex having degree  $l \geq 3$ ,  $v_i$  ( $1 \leq i \leq l$ ) the leaves of the tree,  $n_i$  ( $1 \leq i \leq l$ ) the distance between  $v$  and  $v_i$ . Without loss of generality, we can assume that Left is the first player.

If at least one of the  $n_i$ 's is equal to 1, Left can play on  $v$ , leaving the graph as  $\Sigma_{i=1}^l Wo^{n_i-1}$  where she has a winning strategy by Lemma 4.29. Assume such  $n_i$  does not exist. If at least two of the  $n_i$ 's are greater than or equal to 3, Left can play on  $v$ , leaving the graph as  $\Sigma_{i=1}^l Wo^{n_i-1}$  where she has a winning strategy by Lemma 4.32. If all  $n_i$ 's are equal to 2, Left can play on a leaf, leaving the graph as  $WSi_{l-1}^o$ , where she has a winning strategy by Lemma 4.35. If all but one  $n_i$  are equal to 2, Left can play on the non-leaf vertex at distance 2 from  $v$ , leaving the graph as  $Wo^{\max_{1 \leq i \leq l} (n_i-3)} + WSi_{l-1}^o$ , where she has a winning strategy by Lemma 4.36.

Hence, the first player has a winning strategy on any tree with exactly one vertex having degree at least three.  $\square$

---

## 4.2 Canonical form of dicot games

---

We now look at a more general universe of games, namely the universe of dicot games. Recall that a game is said to be *dicot* either if it is  $\{\cdot|\cdot\}$  or if it has both Left and Right options and all these options are dicot.

**Example 4.38** Figure 4.8 gives three examples of games that are dicot. The first game has both a Left option and a Right option, and both these options are 0, so are dicot. One may recognise the game  $*$  =  $\{0|0\}$  introduced in the introduction. The second game has two Left options and a Right option, and all these options are 0 or  $*$ , so are dicot. The third game has a Left option and two Right options, and we can see all these options are dicot. Figure 4.9 gives three examples of games that are not dicot. The first game has a Left option but no Right option. The second game has both a Left option and a Right option, but, though the Right option is dicot, the Left option is not dicot as it has a Right option but no Left option. The third game has both a Left option and a Right option, but none of these options is dicot as they are numbers in normal canonical form.

The universe of dicots contains all impartial games as well as many partizan games such as all CLOBBER positions.

In normal play, dicot games are called *all-small*, because if a player has a significant advantage in a game, adding any dicot position cannot prevent them from winning. In misère play, this is not the case, as Siegel proved in [38] that for any game  $G$ , there exists a dicot game  $G'$  such that  $G + G'$  is a misère  $\mathcal{P}$ -position.

In this section, we define a reduced form for dicot games, prove that it is actually a canonical form, and count the number of dicot games in canonical form born by day 3.

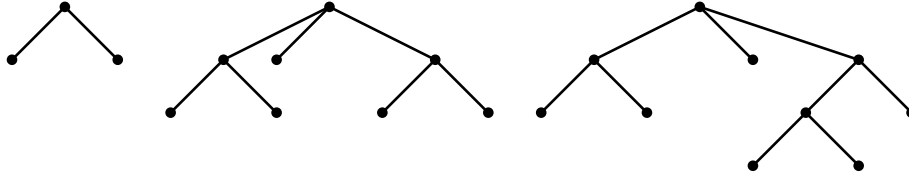


Figure 4.8: Some dicot positions

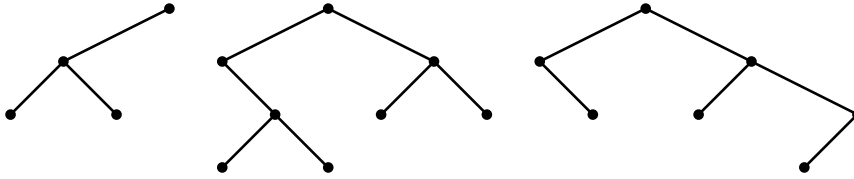


Figure 4.9: Some positions that are not dicot

### 4.2.1 Definitions and universal properties

We start by giving some more definitions and stating results valid for any universe, but before that, we prove the closure of the dicot universe under the three aspects we mentioned in the introduction of this chapter: it is closed under followers, closed under disjunctive sum, and closed under conjugates.

**Lemma 4.39** *If  $G$  is dicot then every follower of  $G$  is dicot.*

**Proof.** We prove the result by induction on the birthday of  $G$ . If  $G = 0$ ,  $G$  is its only follower, and is dicot, so the result holds. Let  $H$  be a follower of  $G$ . If  $H$  is  $G$  or an option of  $G$ , then it follows from the definition of dicots. Otherwise,  $H$  is a follower of an option  $G'$  of  $G$ , and as  $G'$  is dicot with a birthday smaller than the birthday of  $G$ , it follows by induction.  $\square$

**Lemma 4.40** *If  $G$  and  $H$  are dicot then  $G + H$  is dicot.*

**Proof.** We prove the result by induction on the birthdays of  $G$  and  $H$ . If  $G = H = 0$ , then  $G + H = 0$  is dicot. Otherwise, we can assume without loss of generality that  $G \neq 0$ . Then, from the definition of dicot, we find Left options of  $G + H$ , namely  $G^L + H$  and possibly  $G + H^L$ . Similarly, we find Right options of  $G + H$ , namely  $G^R + H$  and possibly  $G + H^R$ . All these options are dicot by induction. Hence  $G + H$  is dicot.  $\square$

**Lemma 4.41** *If  $G$  is dicot, then  $\overline{G}$  is dicot.*

**Proof.** We prove the result by induction on the birthday of  $G$ . If  $G = 0$ , then  $\overline{G} = 0$  is dicot. Otherwise, we find Left options of  $\overline{G}$ , namely  $\overline{G^R}$ .

Similarly, we find Right options of  $\overline{G}$ , namely  $\overline{G^L}$ . All these options are dicot by induction. Hence  $\overline{G}$  is dicot.  $\square$

In [38], Siegel introduced the notion of the adjoint of a game. Recall that a Left end is a game with no Left option, and a Right end is a game with no Right option.

**Definition 4.42 (Siegel [38])** The adjoint of  $G$ , denoted  $G^o$ , is given by

$$G^o = \begin{cases} * & \text{if } G = 0, \\ \{(G^R)^o | 0\} & \text{if } G \neq 0 \text{ and } G \text{ is a Left end,} \\ \{0 | (G^L)^o\} & \text{if } G \neq 0 \text{ and } G \text{ is a Right end,} \\ \{(G^R)^o | (G^L)^o\} & \text{otherwise.} \end{cases}$$

where  $(G^R)^o$  denotes the set of adjoints of elements of  $G^R$ .

Observe that we can recursively verify that the adjoint of any game is dicot. In normal play, the conjugate of a game is considered as its opposite and is thus denoted  $-G$ , since  $G + \overline{G} \equiv^+ 0$ . The interest of the adjoint of a game is that it plays a similar role as the opposite of a game in normal play, to force a win for the second player recursively, as the following proposition suggests:

**Proposition 4.43 (Siegel [38])** *For any game  $G$ ,  $G + G^o$  is a misère  $\mathcal{P}$ -position.*

The following proposition was stated in [38] for the universe  $\mathcal{G}$  of all games. Mimicking the proof, we extend it to any universe.

**Proposition 4.44** *Let  $\mathcal{U}$  be a universe of games,  $G$  and  $H$  two games (not necessarily in  $\mathcal{U}$ ). We have  $G \geq_{\mathcal{U}}^- H$  if and only if the following two conditions hold:*

- (i) *For all  $X \in \mathcal{U}$  with  $o^-(H + X) \geq \mathcal{P}$ , we have  $o^-(G + X) \geq \mathcal{P}$ ; and*
- (ii) *For all  $X \in \mathcal{U}$  with  $o^-(H + X) \geq \mathcal{N}$ , we have  $o^-(G + X) \geq \mathcal{N}$ .*

**Proof.** The sufficiency follows from the definition of  $\geq$ . For the converse, we must show that  $o^-(G + X) \geq o^-(H + X)$  for all  $X \in \mathcal{U}$ . Since we always have  $o^-(G + X) \geq \mathcal{R}$ , if  $o^-(H + X) = \mathcal{R}$ , then there is nothing to prove. If  $o^-(H + X) = \mathcal{P}$  or  $\mathcal{N}$ , the result directly follows from (i) or (ii), respectively. Finally, if  $o^-(H + X) = \mathcal{L}$ , then by (i) and (ii) we have both  $o^-(G + X) \geq \mathcal{P}$  and  $o^-(G + X) \geq \mathcal{N}$ , hence  $o^-(G + X) = \mathcal{L}$ .  $\square$

To obtain the canonical form of a game, we generally remove or bypass options that are not relevant. These options are of two types: dominated options can be removed because another option is always a better move



for the player, and reversible options are bypassed since the answer of the opponent is ‘predictable’. Under normal play, simply removing dominated options and bypassing reversible options is sufficient to obtain a canonical form. Under misère play, Mesdal and Ottaway [25] proposed definitions of dominated and reversible options under misère play in the universe  $\mathcal{G}$  of all games, proving that deleting dominated options and bypassing reversible options does not change the equivalence class of a game in general misère play, then Siegel [38] proved that applying these operations actually defines a canonical form in the universe  $\mathcal{G}$ . Hence the same method may be applied to obtain a misère canonical form. However, modulo smaller universes, games with different canonical forms may be equivalent. In the following, we adapt the definition of dominated and reversible options to restricted universes of games. We show in the next subsection that a canonical form modulo the universe of dicots can be obtained by removing dominated options and applying a slightly more complicated treatment to reversible options.

**Definition 4.45 ( $\mathcal{U}$ -dominated and reversible options)**

Let  $G$  be a game,  $\mathcal{U}$  a universe of games.

- (a) A Left option  $G^L$  is  $\mathcal{U}$ -dominated by some other Left option  $G^{L'}$  if  $G^{L'} \geq_{\mathcal{U}}^- G^L$ .
- (b) A Right option  $G^R$  is  $\mathcal{U}$ -dominated by some other Right option  $G^{R'}$  if  $G^{R'} \leq_{\mathcal{U}}^- G^R$ .
- (c) A Left option  $G^L$  is  $\mathcal{U}$ -reversible through some Right option  $G^{LR}$  if  $G^{LR} \leq_{\mathcal{U}}^- G$ .
- (d) A Right option  $G^R$  is  $\mathcal{U}$ -reversible through some Left option  $G^{RL}$  if  $G^{RL} \geq_{\mathcal{U}}^- G$ .

To obtain the known canonical forms for the universe  $\mathcal{G}$  of all games [38] but also for the universe  $\mathcal{I}$  of impartial games [10], one may just remove dominated and bypass reversible options as defined. The natural question that arises is whether a similar process gives canonical forms in other universes. Indeed, it is remarkable that in all universes closed by followers, dominated options can be ignored, as shown by the following lemma.

**Lemma 4.46** *Let  $G$  be a game and let  $\mathcal{U}$  be a universe of games closed by taking option of games. Suppose  $G^{L_1}$  is  $\mathcal{U}$ -dominated by  $G^{L_2}$ , and let  $G'$  be the game obtained by removing  $G^{L_1}$  from  $G^L$ . Then  $G \equiv_{\mathcal{U}}^- G'$ .*

**Proof.** By Proposition 4.4, we have  $G' \leq_{\mathcal{U}}^- G$ . We thus only have to show that  $G' \geq_{\mathcal{U}}^- G$ . For a game  $X \in \mathcal{U}$ , suppose Left can win  $G + X$  playing first (respectively second), we show that she also has a winning strategy in  $G' + X$ . Actually, she can simply follow the same strategy on  $G' + X$ , unless she is eventually supposed to make a move from some  $G + Y$  to  $G^{L_1} + Y$ . In that case, she is supposed to move to the game  $G^{L_2} + Y$  and then win,

so  $o^-(G^{L_1} + Y) \geq \mathcal{P}$ . But  $G^{L_2} \geq_{\mathcal{U}}^- G^{L_1}$  and  $Y \in \mathcal{U}$ , thus  $o^-(G^{L_2} + Y) \geq \mathcal{P}$ . Therefore, Left can win by moving from  $G' + Y$  to  $G^{L_2} + Y$ , concluding the proof.  $\square$

Note that in the case that interest us here, that is when  $G$  is dicot, the obtained game  $G'$  stays dicot.

Unfortunately, the case involving reversible options is more complex. Nevertheless, we show in the next subsection how we can deal with them in the specific universe of dicot games. Beforehand, we adapt the definition of downlinked or uplinked games from [38] to restricted universes.

**Definition 4.47** *Let  $G$  and  $H$  be any two games. If there exists some  $T \in \mathcal{U}$  such that  $o^-(G + T) \leq \mathcal{P} \leq o^-(H + T)$ , we say that  $G$  is  $\mathcal{U}$ -downlinked to  $H$  (by  $T$ ). In that case, we also say that  $H$  is  $\mathcal{U}$ -uplinked to  $G$  by  $T$ .*

Note that if two games are  $\mathcal{U}$ -downlinked and  $\mathcal{U} \subseteq \mathcal{U}'$ , then these two games are also  $\mathcal{U}'$ -downlinked. Therefore, the smaller the universe  $\mathcal{U}$  is, the less ‘likely’ it is that two games are  $\mathcal{U}$ -downlinked.

**Lemma 4.48** *Let  $G$  and  $H$  be any two games and  $\mathcal{U}$  be a universe of games. If  $G \geq_{\mathcal{U}}^- H$ , then  $G$  is  $\mathcal{U}$ -downlinked to no  $H^L$  and no  $G^R$  is  $\mathcal{U}$ -downlinked to  $H$ .*

**Proof.** Let  $T \in \mathcal{U}$  be any game such that  $o^-(G+T) \leq \mathcal{P}$ . Since  $G \geq_{\mathcal{U}}^- H$  and  $T \in \mathcal{U}$ ,  $o^-(H+T) \leq \mathcal{P}$  as well. Hence for any  $H^L \in H^L$ ,  $o^-(H^L+T) \leq \mathcal{N}$ , and  $G$  is not  $\mathcal{U}$ -downlinked to  $H^L$  by  $T$ . Similarly, let  $T' \in \mathcal{U}$  such that  $o^-(H+T') \geq \mathcal{P}$ . Then  $o^-(G+T') \geq \mathcal{P}$  and therefore, for any  $G^R \in G^R$ ,  $o^-(G^R+T') \geq \mathcal{N}$  and  $G^R$  is not  $\mathcal{U}$ -downlinked to  $H$  by  $T'$ .  $\square$

## 4.2.2 Canonical form of dicot games

In this subsection, we consider games within the universe  $\mathcal{D}$  of dicots, and show that we can define precisely a canonical form in that context. In order to do so, we first describe how to bypass the  $\mathcal{D}$ -reversible options in Lemmas 4.49 and 4.50.

**Lemma 4.49** *Let  $G$  be a dicot game. Suppose  $G^{L_1}$  is  $\mathcal{D}$ -reversible through  $G^{L_1 R_1}$  and either  $G^{L_1 R_1} \neq 0$  or there exists another Left option  $G^{L_2}$  of  $G$  such that  $o^-(G^{L_2}) \geq \mathcal{P}$ . Let  $G'$  be the game obtained by bypassing  $G^{L_1}$ :*

$$G' = \{(G^{L_1 R_1})^L, G^L \setminus \{G^{L_1}\} | G^R\}.$$

*Then  $G'$  is a dicot game and  $G \equiv_{\mathcal{D}}^- G'$ .*

**Proof.** First observe that since  $G$  is dicot, all options of  $G'$  are dicot, and under our assumptions,  $G'$  has both Left and Right options. Thus  $G'$  is a

dicot game. We now prove that for any dicot game  $X$ , the games  $G + X$  and  $G' + X$  have the same misère outcome.

Suppose Left can win playing first (respectively second) on  $G + X$ . Among all the winning strategies for Left, consider one that always recommends a move on  $X$ , unless the only winning move is on  $G$ . In the game  $G' + X$ , let Left follow the same strategy except if the strategy recommends precisely the move from  $G$  to  $G^{L1}$ . In that case, the position is of the form  $G' + Y$ , with  $o^-(G^{L1} + Y) \geq \mathcal{P}$ . Thus  $o^-(G^{L1R1} + Y) \geq \mathcal{N}$ .

Suppose Left has a winning move in  $Y$  from  $G^{L1R1} + Y$ , i.e. there exists some  $Y^L$  such that  $o^-(G^{L1R1} + Y^L) \geq \mathcal{P}$ . But then by reversibility,  $o^-(G + Y^L) \geq \mathcal{P}$ , contradicting our choice of Left's strategy. So either Left has a winning move of type  $G^{L1R1L} + Y$ , which she can play directly from  $G' + Y$ , or she wins because she has no possible moves, meaning that  $G^{L1R1} = 0$  and  $Y = 0$ . In that case, she can also win in  $G' + Y = G'$  by choosing the winning move to  $G^{L2}$ .

Now suppose Right can win playing first (respectively second) on  $G + X$ . Consider any winning strategy for Right, and let him follow exactly the same strategy on  $G' + X$  unless Left moves from some position  $G' + Y$  to  $G^{L1R1L} + Y$ . First note that by our assumption,  $G'$  is not a Left end, thus if Right follows this strategy, Left can never run out of move prematurely.

Suppose now that Left made a move from some position  $G' + Y$  to  $G^{L1R1L} + Y$ . Until that move, Right was following his winning strategy, so  $o^-(G + Y) \leq \mathcal{P}$ . Since  $G^{L1R1} \leq_{\mathcal{D}}^- G$  and  $Y$  is a dicot, we have  $o^-(G^{L1R1} + Y) \leq \mathcal{P}$ . Thus  $G^{L1R1L} + Y \leq \mathcal{N}$  and Right can adapt his strategy.  $\square$

With the previous lemma, we do not bypass reversible options through 0 when all other Left options have misère outcome at most  $\mathcal{N}$ . Such reversible options cannot be treated similarly, as shows the example of the game  $\{0, *|*\}$ . Note that as shown in [2] and [3],  $\{*|*\} = * + * \equiv_{\mathcal{D}}^- 0$  and thus, by Proposition 4.4,  $\{0, *|*\} \geq_{\mathcal{D}}^- 0$ . Therefore, the Left option  $*$  is  $\mathcal{D}$ -reversible through 0. However,  $\{0, *|*\} \not\equiv_{\mathcal{D}}^- \{0|*\}$  since the first is an  $\mathcal{N}$ -position and the second is an  $\mathcal{R}$ -position. Yet, we prove with the following lemma that all reversible options ignored by Lemma 4.49 can be replaced by  $*$  without changing the equivalence class of the game.

**Lemma 4.50** *Let  $G$  be a dicot game. Suppose  $G^{L1}$  is  $\mathcal{D}$ -reversible through  $G^{L1R1} = 0$ . Let  $G'$  be the game obtained by replacing  $G^{L1}$  by  $*$ :*

$$G' = \{*, G^L \setminus \{G^{L1}\} | G^R\}.$$

*Then  $G'$  is a dicot game and  $G \equiv_{\mathcal{D}}^- G'$ .*

**Proof.** First observe that since  $G$  and  $*$  are dicots, all options of  $G'$  are dicots, and  $G'$  has both Left and Right options. Thus  $G'$  is a dicot game.

We now prove that for any dicot game  $X$ , the games  $G + X$  and  $G' + X$  have the same misère outcome.

Suppose Left can win playing first (respectively second) on  $G + X$ . Among all the winning strategies for Left, consider one that always recommends a move on  $X$ , unless the only winning move is on  $G$ . In the game  $G' + X$ , let Left follow the same strategy except if the strategy recommends precisely the move from  $G$  to  $G^{L_1}$ . In that case, the position is of the form  $G' + Y$ , with  $o^-(G^{L_1} + Y) \geq \mathcal{P}$ . Thus  $o^-(G^{L_1 R_1} + Y) \geq \mathcal{N}$ .

Suppose Left has a winning move in  $G^{L_1 R_1} + Y = 0 + Y = Y$ , i.e. there exists some  $Y^L$  such that  $o^-(Y^L) \geq \mathcal{P}$ . But then by reversibility,  $o^-(G + Y^L) \geq \mathcal{P}$ , contradicting our choice of Left's strategy. So Left has no winning move in  $Y$ , and she wins because she has no possible moves, i.e.  $Y = 0$ . In that case, she can also win in  $G' + Y = G'$  by choosing the winning move to  $*$ .

Now suppose Right can win playing first (respectively second) on  $G + X$ . Consider any winning strategy for Right, and let him follow exactly the same strategy on  $G' + X$  unless Left moves from some position  $G' + Y$  to  $* + Y$ . First note that by our assumption,  $G'$  is not a Left end, thus if Right follows this strategy, Left can never run out of move prematurely.

Suppose now that Left made a move from some position  $G' + Y$  to  $* + Y$ . Until that move, Right was following his winning strategy, so  $o^-(G + Y) \leq \mathcal{P}$ . Since  $0 = G^{L_1 R_1} \leq_{\mathcal{D}}^- G$  and  $Y$  is dicot, we have  $o^-(Y) = o^-(0 + Y) \leq o^-(G + Y) \leq \mathcal{P}$ . So Right can move from  $* + Y$  to  $Y$  and win.  $\square$

Note that some reversible options may be dealt with using both Lemmas 4.49 and 4.50. Yet, it is still possible to apply Lemma 4.49 and remove such an option after having applied Lemma 4.50.

At this point, we want to define a reduced form for each game obtained by applying the preceding lemmas as long as we can. In addition, it was proved by Allen in [2] and [3] that the game  $\{*\mid*\}$  is equivalent to 0 modulo the universe of dicot games, and we thus reduce this game to 0. Therefore, we define the reduced form of a dicot game as follows:

**Definition 4.51 (Reduced form)** Let  $G$  be a dicot. We say  $G$  is in *reduced form* if:

- (i) it is not  $\{*\mid*\}$ ,
- (ii) it contains no dominated option,
- (iii) if Left has a reversible option, it is  $*$  and no other Left option has outcome  $\mathcal{P}$  or  $\mathcal{L}$ ,
- (iv) if Right has a reversible option, it is  $*$  and no other Right option has outcome  $\mathcal{P}$  or  $\mathcal{R}$ ,
- (v) all its options are in reduced form.

Observe first the following:

**Theorem 4.52** *Every game  $G$  is equivalent modulo the universe of dicots to a game in reduced form  $H$  whose birthday is no larger than the birthday of  $G$ .*

**Proof.** To obtain a game  $H$  equivalent to  $G$  in reduced form, we can apply iteratively Lemmas 4.46, 4.49 and 4.50. Applying these lemmas, we never increase the depth of the corresponding game tree, thus the birthday of the reduced game  $H$  is no larger than the birthday of  $G$ .  $\square$

We now prove that the reduced form of a game can be seen as a canonical form. Before stating the main theorem, we need the two following lemmas.

**Lemma 4.53** *Let  $G$  and  $H$  be any games. If  $G \not\geq_{\mathcal{D}}^- H$ , then:*

- (a) *There exists some  $Y \in \mathcal{D}$  such that  $o^-(G+Y) \leq \mathcal{P}$  and  $o^-(H+Y) \geq \mathcal{N}$ ;*  
and
- (b) *There exists some  $Z \in \mathcal{D}$  such that  $o^-(G+Z) \leq \mathcal{N}$  and  $o^-(H+Z) \geq \mathcal{P}$ .*

**Proof.** Negating the condition of Proposition 4.44, we get that (a) or (b) must hold. To prove the lemma, we show that (a)  $\Rightarrow$  (b) and (b)  $\Rightarrow$  (a).

Consider some  $Y \in \mathcal{D}$  such that  $o^-(G+Y) \leq \mathcal{P}$  and  $o^-(H+Y) \geq \mathcal{N}$ , and set

$$Z = \{(H^{\mathbf{R}})^o, 0|Y\}.$$

First note that since  $Z$  has both a Left and a Right option, and all its options are dicots,  $Z$  is also dicot. We now show that  $Z$  satisfies  $o^-(G+Z) \leq \mathcal{N}$  and  $o^-(H+Z) \geq \mathcal{P}$ , as required in (b). From the game  $G+Z$ , Right has a winning move to  $G+Y$ , so  $o^-(G+Z) \leq \mathcal{N}$ . We now prove that Right has no winning move in the game  $H+Z$ . Observe first that  $H+Z$  is not a Right end since  $Z$  is not. If Right moves to some  $H^{\mathbf{R}}+Z$ , Left has a winning response to  $H^{\mathbf{R}}+(H^{\mathbf{R}})^o$ . If instead Right moves to  $H+Y$  then, since  $o^-(H+Y) \geq \mathcal{N}$ , Left can win. Therefore  $o^-(H+Z) \geq \mathcal{P}$ , and (a)  $\Rightarrow$  (b).

To prove (b)  $\Rightarrow$  (a), for a given  $Z$  we set  $Y = \{Z|0, (G^{\mathbf{L}})^o\}$  and prove similarly that Left wins if she plays first on  $H+Y$  and loses if she plays first on  $G+Y$ .  $\square$

**Lemma 4.54** *Let  $G$  and  $H$  be any games. The game  $G$  is  $\mathcal{D}$ -downlinked to  $H$  if and only if no  $G^{\mathbf{L}} \geq_{\mathcal{D}}^- H$  and no  $H^{\mathbf{R}} \leq_{\mathcal{D}}^- G$ .*

**Proof.** Consider two games  $G$  and  $H$  such that  $G$  is  $\mathcal{D}$ -downlinked to  $H$  by some third game  $T$ , i.e.  $o^-(G+T) \leq \mathcal{P} \leq o^-(H+T)$ . Then Left has no winning move from  $G+T$ , thus  $o^-(G^{\mathbf{L}}+T) \leq \mathcal{N}$  and similarly  $o^-(H^{\mathbf{R}}+T) \geq \mathcal{N}$ . Therefore,  $T$  witnesses both  $G^{\mathbf{L}} \not\geq_{\mathcal{D}}^- H$  and  $G \not\geq_{\mathcal{D}}^- H^{\mathbf{R}}$ .

Conversely, suppose that no  $G^{\mathbf{L}} \geq_{\mathcal{D}}^- H$  and no  $H^{\mathbf{R}} \leq_{\mathcal{D}}^- G$ . Set  $G^{\mathbf{L}} = \{G_1^{\mathbf{L}}, \dots, G_k^{\mathbf{L}}\}$  and  $H^{\mathbf{R}} = \{H_1^{\mathbf{R}}, \dots, H_\ell^{\mathbf{R}}\}$ . By Lemma 4.53, we can

associate to each  $G_i^L \in G^L$  a game  $X_i \in \mathcal{D}$  such that  $o^-(G_i^L + X_i) \leq \mathcal{P}$  and  $o^-(H + X_i) \geq \mathcal{N}$ . Likewise, to each  $H_j^R \in H^R$ , we associate a game  $Y_j \in \mathcal{D}$  such that  $o^-(G + Y_j) \leq \mathcal{N}$  and  $o^-(H_j^R + Y_j) \geq \mathcal{P}$ . Let  $T$  be the game defined by

$$T^L = \begin{cases} \{0\} & \text{if both } G \text{ and } H \text{ are Right ends,} \\ (G^R)^o \cup \{Y_j \mid 1 \leq j \leq \ell\} & \text{otherwise.} \end{cases}$$

$$T^R = \begin{cases} \{0\} & \text{if both } G \text{ and } H \text{ are Left ends,} \\ (H^L)^o \cup \{X_i \mid 1 \leq i \leq k\} & \text{otherwise.} \end{cases}$$

If  $H^R$  (respectively  $G^R$ ) is non-empty, then so is  $\{Y_j \mid 1 \leq j \leq \ell\}$  (respectively  $(G^R)^o$ ), and  $T$  has a Left option. If both  $G^R$  and  $H^R$  are empty, then  $T^L = \{0\}$ , so  $T$  always has a Left option. Similarly,  $T$  also always has a Right option. Moreover, all these options are dicots, so  $T$  is dicot. We claim that  $G$  is  $\mathcal{D}$ -downlinked to  $H$  by  $T$ .

To show that  $o^-(G + T) \leq \mathcal{P}$ , we just prove that Left loses if she plays first in  $G + T$ . Since  $T$  has a Left option,  $G + T$  is not a Left end. If Left moves to some  $G_i^L + T$ , then by our choice of  $X_i$ , Right has a winning response to  $G_i^L + X_i$ . If Left moves to some  $G + (G^R)^o$ , then Right can respond to  $G^R + (G^R)^o$  and win (by Proposition 4.43). If Left moves to  $G + Y_j$ , then by our choice of  $Y_j$ ,  $o^-(G + Y_j) \leq \mathcal{N}$  and Right can win. The only remaining possibility is, when  $G$  and  $H$  are Right ends, that Left moves to  $G + 0$ . But then Right cannot move and wins.

Now, we show that  $o^-(H + T) \geq \mathcal{P}$  by proving that Right loses playing first in  $H + T$ . If Right moves to some  $H_j^R + T$ , then Left has a winning response to  $H_j^R + Y_j$ . If Right moves to  $H + (H^L)^o$ , then Left wins by playing to  $H^L + (H^L)^o$ , and if Right moves to  $H + X_i$ , then by our choice of  $X_i$ ,  $o^-(H + X_i) \geq \mathcal{N}$  and Left can win. Finally, the only remaining possibility, when  $G$  and  $H$  are Left ends, is that Right moves to 0. But then Left cannot answer and wins.  $\square$

We now prove the main theorem of the section.

**Theorem 4.55** *Consider two dicot games  $G$  and  $H$ . If  $G \equiv_{\mathcal{D}}^- H$  and both are in reduced form, then  $G = H$ .*

**Proof.** If  $G = H = 0$ , the result is clear. We proceed by induction on the birthdays of the games. Assume without loss of generality that  $G$  has an option. Since  $G$  is dicot, it has both a Left and a Right option.

Consider a Left option  $G^L$ . Suppose first that  $G^L$  is not  $\mathcal{D}$ -reversible. Since  $H \equiv_{\mathcal{D}}^- G$ ,  $H \geq_{\mathcal{D}}^- G$  and Lemma 4.48 implies that  $H$  is not downlinked to  $G^L$ . Then by Lemma 4.54, either there exists some  $H^L \geq_{\mathcal{D}}^- G^L$ , or there exists some Right option  $G^{LR}$  of  $G^L$  with  $G^{LR} \leq_{\mathcal{D}}^- H$ . The latter would imply that  $G \geq_{\mathcal{D}}^- G^{LR}$  and thus that  $G^L$  is  $\mathcal{D}$ -reversible, contradicting our assumption. So we must have some option  $H^L$  such that  $H^L \geq_{\mathcal{D}}^- G^L$ . A

similar argument for  $H^L$  gives that there exists some Left option  $G^{L'}$  of  $G$  such that  $G^{L'} \geq_{\mathcal{D}}^- H^L$ . Therefore  $G^{L'} \geq_{\mathcal{D}}^- H^L \geq_{\mathcal{D}}^- G^L$ . If  $G^{L'}$  and  $G^L$  are two different options, then  $G^L$  is dominated by  $G^{L'}$ , contradicting our assumption that  $G$  is in reduced form. Thus,  $G^{L'}$  and  $G^L$  are the same option, and  $G^L \equiv_{\mathcal{D}}^- H^L$ . But  $G^L$  and  $H^L$  are in reduced form, so by induction hypothesis,  $G^L = H^L$ . The same argument applied to the Right options of  $G$  and to the options of  $H$  shows the pairwise correspondence of all non- $\mathcal{D}$ -reversible options of  $G$  and  $H$ .

Assume now that  $G^L$  is a  $\mathcal{D}$ -reversible option. Then  $G^L = *$  and for all other Left options  $G^{L'}$ , we have  $o^-(G^{L'}) \leq \mathcal{N}$ , and by reversibility, there exists some Right option  $G^{LR}$  of  $G^L$  such that  $G^{LR} \leq_{\mathcal{D}}^- G$ . Since the only Right option of  $*$  is 0,  $G \geq_{\mathcal{D}}^- 0$ . Thus  $H \geq_{\mathcal{D}}^- 0$ , so either  $H = 0$  or Left has a winning move in  $H$ , namely a Left option  $H^L$  such that  $o^-(H^L) \geq \mathcal{P}$ . First assume  $H = 0$ . Then by the pairwise correspondence proved earlier,  $G$  has no non- $\mathcal{D}$ -reversible options. Yet it is a dicot and must have both a Left and a Right option, and since it is in reduced form, both are  $*$ . Then  $G = \{*\}$ , a contradiction. Now assume  $H$  has a Left option  $H^L$  such that  $o^-(H^L) \geq \mathcal{P}$ . If  $H^L$  is not  $\mathcal{D}$ -reversible, then it is in correspondence with a non- $\mathcal{D}$ -reversible option  $G^{L'}$ , but then we should have  $o^-(H^L) = o^-(G^{L'}) \leq \mathcal{N}$ , a contradiction. So  $H^L$  is  $\mathcal{D}$ -reversible, and  $H^L = G^L = *$ . The same argument applied to possible Right  $\mathcal{D}$ -reversible options concludes the proofs that  $G = H$ .  $\square$

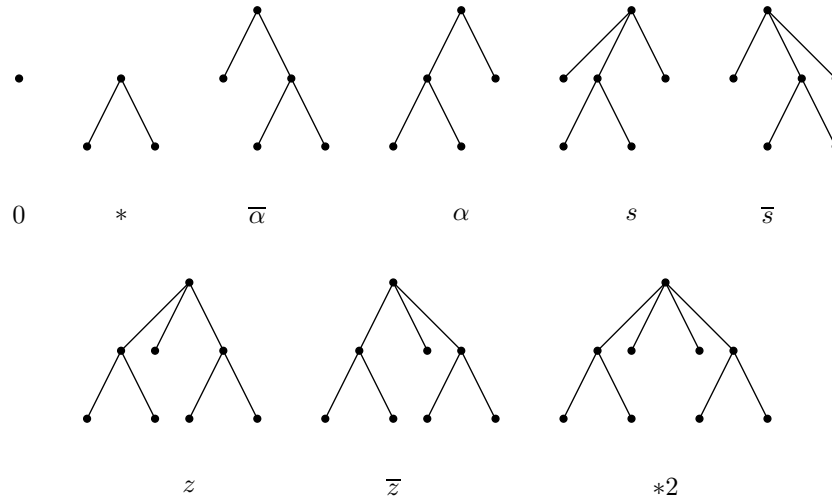
This proves that the reduced form of a game is unique, and that any two  $\mathcal{D}$ -equivalent games have the same reduced form. Therefore, the reduced form as described in Definition 4.51 can be considered as the canonical form of the game modulo the universe of dicot games.

Siegel showed in [38] that for any games  $G$  and  $H$ , if  $G \geq^- H$ , then  $G \geq^+ H$  also in normal play. This result can be strengthened as follows :

**Theorem 4.56** *Let  $G$  and  $H$  be any games. If  $G \geq_{\mathcal{D}}^- H$ , then  $G \geq^+ H$ .*

**Proof.** Consider any two games  $G$  and  $H$  such that  $G \geq_{\mathcal{D}}^- H$ . We show that  $G + \overline{H} \geq^+ 0$ , i.e. that Left can win  $G + \overline{H}$  in normal play when Right moves first [4], by induction on the birthdays of  $G$  and  $H$ . Suppose Right plays to some  $G^R + \overline{H}$ . Since  $G \geq_{\mathcal{D}}^- H$ , Lemma 4.48 implies  $G^R$  is not  $\mathcal{D}$ -downlinked to  $H$ . By Lemma 4.54, either there exists some Left option  $G^{RL}$  of  $G^R$  with  $G^{RL} \geq_{\mathcal{D}}^- H$ , or there exists some Right option  $H^R$  of  $H$  with  $G^R \geq_{\mathcal{D}}^- H^R$ . In the first case, we get by induction that  $G^{RL} \geq^+ H$  and Left can win by moving to  $G^{RL} + \overline{H}$ . In the second case, we get  $G^R \geq^+ H^R$ , and Left can win by moving to  $G^R + \overline{H^R}$ . The argument when Right plays to some  $G + \overline{H^L}$  is similar.  $\square$

Theorem 4.56 implies in particular that if two games are equivalent in misère play modulo  $\mathcal{D}$ , then they are also equivalent in normal play. It allows us to use any normal play tools to prove incomparability or distinguishability



**Figure 4.10:** Game trees of the 9 dicot games born by day 2

(i.e. non equivalence) to deduce it modulo the universe of dicot games. Moreover, a corollary of Theorem 4.56 is that its statement is also true for any universe containing  $\mathcal{D}$ , in particular for the universe  $\mathcal{G}$  of all games (implying the result of [38]) and for the universe  $\mathcal{E}$  of dead-ending games we study in the next section.

**Corollary 4.57** *Let  $G$  and  $H$  be any games,  $\mathcal{U}$  a universe containing all dicot positions. If  $G \geq_{\mathcal{U}}^- H$ , then  $G \geq^+ H$ .*

### 4.2.3 Dicot misère games born by day 3

We now use Theorem 4.55 to count the dicot misère games born by day 3. Recall that the numbers of impartial misère games distinguishable modulo the universe  $\mathcal{I}$  of impartial games that are born by day 0, 1, 2, 3 and 4 are respectively 1, 2, 3, 5 and 22 (see [10]). Siegel [38] proved that the numbers of misère games distinguishable modulo the universe  $\mathcal{G}$  of all games that are born by day 0, 1 and 2 are respectively 1, 4 and 256, while the number of distinguishable misère games born by day 3 is less than  $2^{183}$ . Notice that since impartial games form a subset of dicot games, the number of dicot games born by day 3 lies between 5 and  $2^{183}$ . Before showing that this number is exactly 1268, we state some properties of the dicot games born by day 2.

**Proposition 4.58** *There are 9 dicot games born by day 2 distinguishable modulo the universe  $\mathcal{D}$  of dicot games, namely  $0$ ,  $*$ ,  $\bar{\alpha} = \{0|*\}$ ,  $\alpha = \{*|0\}$ ,  $s = \{0,*|0\}$ ,  $z = \{0,*|*\}$ ,  $\bar{z} = \{0|0,*\}$ ,  $\bar{z} = \{*|0,*\}$ , and  $*2 = \{0,*|0,*\}$  (see Figure 4.10). They are partially ordered according to Figure 4.11. Moreover, the outcomes of their sums are given in Table 4.12.*



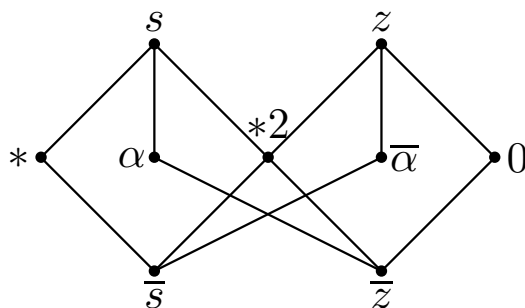


Figure 4.11: Partial ordering of dicot games born by day 2

	0	*	$\bar{\alpha}$	$\alpha$	s	z	$\bar{s}$	$\bar{z}$	*2
0	$\mathcal{N}$	$\mathcal{P}$	$\mathcal{R}$	$\mathcal{L}$	$\mathcal{L}$	$\mathcal{N}$	$\mathcal{R}$	$\mathcal{N}$	$\mathcal{N}$
*	$\mathcal{P}$	$\mathcal{N}$	$\mathcal{N}$	$\mathcal{N}$	$\mathcal{N}$	$\mathcal{L}$	$\mathcal{N}$	$\mathcal{R}$	$\mathcal{N}$
$\bar{\alpha}$	$\mathcal{R}$	$\mathcal{N}$	$\mathcal{P}$	$\mathcal{N}$	$\mathcal{N}$	$\mathcal{P}$	$\mathcal{R}$	$\mathcal{R}$	$\mathcal{R}$
$\alpha$	$\mathcal{L}$	$\mathcal{N}$	$\mathcal{N}$	$\mathcal{P}$	$\mathcal{L}$	$\mathcal{L}$	$\mathcal{N}$	$\mathcal{P}$	$\mathcal{L}$
s	$\mathcal{L}$	$\mathcal{N}$	$\mathcal{N}$	$\mathcal{L}$	$\mathcal{L}$	$\mathcal{L}$	$\mathcal{N}$	$\mathcal{P}$	$\mathcal{L}$
z	$\mathcal{N}$	$\mathcal{L}$	$\mathcal{P}$	$\mathcal{L}$	$\mathcal{L}$	$\mathcal{L}$	$\mathcal{P}$	$\mathcal{N}$	$\mathcal{L}$
$\bar{s}$	$\mathcal{R}$	$\mathcal{N}$	$\mathcal{R}$	$\mathcal{N}$	$\mathcal{N}$	$\mathcal{P}$	$\mathcal{R}$	$\mathcal{R}$	$\mathcal{R}$
$\bar{z}$	$\mathcal{N}$	$\mathcal{R}$	$\mathcal{R}$	$\mathcal{P}$	$\mathcal{P}$	$\mathcal{N}$	$\mathcal{R}$	$\mathcal{R}$	$\mathcal{R}$
*2	$\mathcal{N}$	$\mathcal{N}$	$\mathcal{R}$	$\mathcal{L}$	$\mathcal{L}$	$\mathcal{L}$	$\mathcal{R}$	$\mathcal{R}$	$\mathcal{P}$

Table 4.12: Outcomes of sums of dicots born by day 2

**Proof.** There are 10 dicot games born by day 2, of which 0 and  $\{*\mid*\}$  are equivalent. We now prove that these nine games are pairwise distinguishable modulo the universe  $\mathcal{D}$  of dicot games<sup>1</sup>. First note that these games are all in reduced form. Indeed, since all options are either 0 or \* which are not comparable modulo  $\mathcal{D}$ , there are no dominated options. Moreover, \* might be reversible through 0, but since there are no other option at least  $\mathcal{P}$ , it cannot be reduced. Thus, by Theorem 4.55, these games are pairwise non-equivalent.

The proof of the outcomes of sums of these games (given in Table 4.12) is tedious but not difficult, and omitted here.

We now show that these games are partially ordered according to Figure 4.11. Using the fact that  $\{*\mid*\} \equiv_{\mathcal{D}} 0$  and Proposition 4.4, we easily infer the relations corresponding to edges in Figure 4.11. All other pairs are incomparable: for each pair  $(X, Y)$ , there exist  $Z_1, Z_2 \in \{0, *, \alpha, \bar{\alpha}, s, \bar{s}, z, \bar{z}\}$  such that  $o^-(X + Z_1) \not\leq o^-(Y + Z_1)$  and  $o^-(X + Z_2) \not\geq o^-(Y + Z_2)$  (see Table 4.13 for explicit such  $Z_1$  and  $Z_2$ ).  $\square$

<sup>1</sup>Milley gave an alternate proof of this fact in [26].

$X$	$Y$	$Z_1$ such that $o^-(X + Z_1) \not\leq o^-(Y + Z_1)$	$Z_2$ such that $o^-(X + Z_2) \not\geq o^-(Y + Z_2)$
$s$	$z$	$\bar{s}$	$\bar{s}$
$s$	$\bar{\alpha}$	$\bar{\alpha}$	$\bar{\alpha}$
$s$	$0$	$\bar{z}$	$\bar{z}$
$z$	$*$	$0$	$0$
$z$	$\alpha$	$\bar{\alpha}$	$\bar{\alpha}$
$*$	$\alpha$	$\alpha$	$\alpha$
$*$	$0$	$0$	$0$
$*$	$*2$	$0$	$0$
$\alpha$	$*2$	$0$	$\alpha$
$\alpha$	$0$	$*$	$*$
$\alpha$	$\bar{\alpha}$	$\alpha$	$\alpha$
$*2$	$0$	$*$	$*$

**Table 4.13:** Incomparability of dicots born by day 2

We now start counting the dicot games born by day 3. Their Left and Right options are necessarily dicot games born by day 2. We can consider only games in their canonical form, so with no  $\mathcal{D}$ -dominated options.

Using Figure 4.11, we find the following 50 antichains:

$$\left\{ \begin{array}{l} \text{all 32 subsets of } \{0, *, \bar{\alpha}, \alpha, *2\}, \\ \{s, z\} \text{ and } \{\bar{s}, \bar{z}\}, \\ 4 \text{ containing } s \text{ and any subset of } \{0, \bar{\alpha}\} \\ 4 \text{ containing } z \text{ and any subset of } \{*, \alpha\} \\ 4 \text{ containing } \bar{s} \text{ and any subset of } \{0, \alpha\} \\ 4 \text{ containing } \bar{z} \text{ and any subset of } \{*, \bar{\alpha}\} \end{array} \right.$$

Therefore, choosing  $G^L$  and  $G^R$  among these antichains, together with the fact that  $G$  is dicot, we get  $49^2 + 1 = 2402$  dicot games born by day 3 with no  $\mathcal{D}$ -dominated options.

To get only games in canonical form, we still have to remove games with  $\mathcal{D}$ -reversible options. Note that an option from a dicot game born by day 3 can only be  $\mathcal{D}$ -reversible through 0 or  $*$  since these are the only dicot games born by day 1. To deal with  $\mathcal{D}$ -reversible options, we consider separately the games with different outcomes. If Left has a winning move from a game  $G$ , namely a move to  $*$ ,  $\alpha$  or  $s$ , or if she has no move from  $G$ , then  $o^-(G) \geq \mathcal{N}$ . Otherwise,  $o^-(G) \leq \mathcal{P}$ . Likewise, if Right has a winning move from  $G$ , namely a move to  $*$ ,  $\bar{\alpha}$  or  $\bar{s}$ , or if he has no move from  $G$ , then  $o^-(G) \leq \mathcal{N}$ . Otherwise,  $o^-(G) \geq \mathcal{P}$ . From this observation, we infer the outcome of any dicot game born by day 3.

Consider first the games  $G$  with outcome  $\mathcal{P}$ , i.e.  $G^L \cap \{*, \alpha, s\} = \emptyset$  and  $G^R \cap \{*, \bar{\alpha}, \bar{s}\} = \emptyset$ . Since  $o^-(0) = \mathcal{N}$ ,  $G$  and  $0$  are  $\mathcal{D}$ -incomparable, so no option of  $G$  is  $\mathcal{D}$ -reversible through  $0$ . The following lemma allows to characterise dicot games born by day 3 whose outcome is  $\mathcal{P}$  and that contain  $\mathcal{D}$ -reversible options through  $*$ .

**Lemma 4.59** *Let  $G$  be a dicot game born by day 3 with misère outcome  $\mathcal{P}$ . We have  $G \geq_{\mathcal{D}}^- *$  if and only if  $G^L \cap \{0, z\} \neq \emptyset$ .*

**Proof.** First suppose that  $G^L \cap \{0, z\} \neq \emptyset$ . Let  $X$  be a dicot game such that Left has a winning strategy on  $*+X$  when playing first (respectively second). Left can follow the same strategy on  $G+X$ , unless the strategy recommends that she plays from some  $*+Y$  to  $0+Y$ , or Right eventually plays from some  $G+Z$  to some  $G^R+Z$ . In the first case, we must have  $o^-(0+Y) \geq \mathcal{P}$ . Left can move from  $G+Y$  either to  $0+Y$  or to  $z+Y$ , which are both winning moves. Indeed, since  $z \geq_{\mathcal{D}}^- 0$ , we have  $o^-(z+Y) \geq o^-(0+Y) \geq \mathcal{P}$ . Suppose now that Right just moved from  $G+Z$  to some  $G^R+Z$ . By our choice of strategy, we have  $o^-(*+Z) \geq \mathcal{P}$ . If  $G^R = 0$ , then Left can continue her strategy since  $0+Z$  is also a Right option of  $*+Z$ . Otherwise, since  $G^R \cap \{*, \bar{\alpha}, \bar{s}\} = \emptyset$ ,  $G^R$  is one of  $\alpha, s, z, \bar{z}, *2$  and  $*$  is a Left option of  $G^R$ . Then Left can play from  $G^R+Z$  to  $*+Z$  and win. Thus, if Left wins  $*+X$ , she wins  $G+X$  as well and thus  $G \geq_{\mathcal{D}}^- *$ .

Suppose now that  $G^L \cap \{0, z\} = \emptyset$ , that is  $G^L \subseteq \{\bar{\alpha}, \bar{s}, \bar{z}, *2\}$ . Let  $X = \{\bar{s}|0\}$ . In  $*+X$ , Left wins playing to  $0+X$  and Right wins playing to  $*+0$ , hence  $o^-(*+X) = \mathcal{N}$ . On the other hand, in  $G+X$ , Right wins by playing to  $G+0$ , but Left has no other option than  $\bar{\alpha}+X$ ,  $\bar{s}+X$ ,  $\bar{z}+X$ ,  $*2+X$ ,  $G+\bar{s}$ . In the last four, Right wins by playing to  $0+X$  or  $G+0$ , both with outcome  $\mathcal{P}$ . In  $\bar{\alpha}+X$ , Right wins by playing to  $\bar{\alpha}+0$  which has outcome  $\mathcal{R}$ . So  $o^-(G+X) = \mathcal{R}$ , and since  $o^-(*+X) = \mathcal{N}$ , we have  $G \not\geq_{\mathcal{D}}^- *$ .  $\square$

We deduce the following theorem:

**Theorem 4.60** *A dicot game  $G$  born by day 3 with outcome  $\mathcal{P}$  is in canonical form if and only if*

$$\begin{cases} G^L \in \{ \{\bar{\alpha}\}, \{\bar{\alpha}, *2\}, \{*2\}, \{\bar{s}\}, \{\bar{s}, \bar{z}\}, \{\bar{z}\}, \{\bar{\alpha}, \bar{z}\}, \{0\} \}, \text{ and} \\ G^R \in \{ \{\alpha\}, \{\alpha, *2\}, \{*2\}, \{s\}, \{s, z\}, \{z\}, \{\alpha, z\}, \{0\} \}. \end{cases}$$

*This yields  $8 \cdot 8 = 64$  dicots non equivalent modulo  $\mathcal{D}$ .*

**Proof.** Let  $G$  be a dicot game born by day 3 with misère outcome  $\mathcal{P}$ , in canonical form. By our earlier statement,  $G^L \subseteq \{0, \bar{\alpha}, \bar{s}, z, \bar{z}, *2\}$ . By Lemma 4.59, options  $\bar{\alpha}, \bar{s}, z, \bar{z}, *2$  are reversible through  $*$  whenever  $G^L \cap \{0, z\} \neq \emptyset$ . So  $z$  is not a Left option of  $G$ , and if  $0$  is, there are no other Left options. Thus the only antichains left for  $G^L$  are

$\{\{\bar{\alpha}\}, \{\bar{\alpha}, *2\}, \{*2\}, \{\bar{s}\}, \{\bar{s}, \bar{z}\}, \{\bar{z}\}, \{\bar{\alpha}, \bar{z}\}, \{0\}\}$ . A similar argument with conjugates gives all possibilities for  $G^R$ .  $\square$

Now we consider games  $G$  with outcome  $\mathcal{L}$ , i.e.  $G^L \cap \{*, \alpha, s\} \neq \emptyset$  and  $G^R \cap \{*, \bar{\alpha}, \bar{s}\} = \emptyset$ . Since  $G \not\leq 0$  and  $G \not\leq *$ , no Right option of  $G$  is  $\mathcal{D}$ -reversible. The two following lemmas allow us to characterise dicot games born by day 3 whose outcome is  $\mathcal{L}$  and that contain  $\mathcal{D}$ -reversible Left options. First, we characterise positions that may contain  $\mathcal{D}$ -reversible Left options through  $*$ .

**Lemma 4.61** *Let  $G$  be a dicot game born by day 3 with misère outcome  $\mathcal{L}$ . We have  $G \geq_{\mathcal{D}}^* *$  if and only if  $G^L \cap \{0, z\} \neq \emptyset$ .*

**Proof.** The proof that if  $G^L \cap \{0, z\} \neq \emptyset$ , then Left wins  $G + X$  whenever she wins  $* + X$  is the same as for Lemma 4.59.

Consider now the case when  $G^L \cap \{0, z\} = \emptyset$ , that is  $G^L \subseteq \{*, \alpha, s, \bar{\alpha}, \bar{s}, \bar{z}, *2\}$ . Assume first that  $\{0, z\} \cap G^R \neq \emptyset$  and let  $X = \{\bar{z}|0\}$ . Recall that in  $* + X$ , Left wins playing to  $0 + X$  and Right wins playing to  $* + 0$ , hence  $o^-(* + X) = \mathcal{N}$ . On the other hand, in  $G + X$ , Left has no other option than  $\bar{\alpha} + X, * + X, \alpha + X, s + X, \bar{s} + X, \bar{z} + X, *2 + X, G + \bar{s}$ . In  $\bar{\alpha} + X$ , Right wins by playing to  $\bar{\alpha} + 0$ , whose outcome is  $\mathcal{R}$ . In  $G + \bar{s}$ , by our assumption, Right can play either to  $0 + \bar{s}$  or to  $z + \bar{s}$ , with outcome  $\mathcal{R}$  and  $\mathcal{P}$  respectively, and thus wins. In all other cases, Right wins by playing to  $0 + X$ , whose outcome is  $\mathcal{P}$ . Thus  $o^-(G + X) \leq \mathcal{P}$ , and since  $o^-(* + X) = \mathcal{N}$ , we have  $G \not\leq_{\mathcal{D}}^* *$ .

Now assume  $\{0, z\} \cap G^R = \emptyset$ , that is  $G^R \subseteq \{\alpha, s, \bar{z}, *2\}$ . Let  $X' = \{\bar{z}|0\}$ . In  $* + X'$ , Left wins playing to  $0 + X'$  and Right wins playing to  $* + 0$ , hence  $o^-(* + X') = \mathcal{N}$ . On the other hand, in  $G + X'$ , Left has no other option than  $G + \bar{z}, \bar{\alpha} + X', * + X', \alpha + X', s + X', \bar{s} + X', \bar{z} + X', *2 + X'$ . In  $\bar{\alpha} + X'$ , Right wins by playing to  $\bar{\alpha} + 0$  whose outcome is  $\mathcal{R}$ . In  $G + \bar{z}$ , Right wins by playing either to  $\alpha + \bar{z}$  or  $s + \bar{z}$ , both with outcome  $\mathcal{P}$ , or to  $\bar{z} + \bar{z}$  or  $*2 + \bar{z}$ , both with outcome  $\mathcal{R}$ . In the remaining cases, Right wins by playing to  $0 + X'$  whose outcome is  $\mathcal{P}$ . Thus  $o^-(G + X') \leq \mathcal{P}$ , and since  $o^-(* + X') = \mathcal{N}$ , we have  $G \not\leq_{\mathcal{D}}^* *$ .  $\square$

Now, we characterise games that may contain  $\mathcal{D}$ -reversible Left options through 0. The following lemma can actually be proved for both games with outcome  $\mathcal{L}$  or  $\mathcal{N}$ , and we also use it for the proof of Theorem 4.64.

**Lemma 4.62** *Let  $G$  be a dicot game born by day 3 with misère outcome  $\mathcal{L}$  or  $\mathcal{N}$ . We have  $G \geq_{\mathcal{D}} 0$  if and only if  $G^R \cap \{0, \alpha, \bar{z}\} = \emptyset$ .*

**Proof.** Suppose first that  $G^R \cap \{0, \alpha, \bar{z}\} = \emptyset$ . Then every Right option of  $G$  has 0 as a Left option. Let  $X$  be a dicot such that Left has a winning strategy on  $0 + X$  when playing first (respectively second). Left can follow the same strategy on  $G + X$  until either Right plays on  $G$  or she has to

move from  $G + 0$ . In the first case, she can answer in  $G^R + Y$  to  $0 + Y$  and continue her winning strategy. In the second case, she wins in  $G + 0$  since  $o^-(G) \geq \mathcal{N}$ . Therefore,  $G \geq_{\mathcal{D}} 0$ .

Consider now the case when  $G^R \cap \{0, \alpha, \bar{z}\} \neq \emptyset$ . Let  $X = \{\bar{\alpha}|0\}$ , note that  $o^-(X) = \mathcal{P}$ . When playing first on  $G + X$ , Right wins by playing either to  $0 + X$  with outcome  $\mathcal{P}$ , or to  $\alpha + X$  or  $\bar{z} + X$ , both with outcome  $\mathcal{R}$ . Hence  $o^-(G + X) \leq \mathcal{N}$  so  $G \not\geq_{\mathcal{D}} 0$ .  $\square$

We now are in position to state the set of dicots born by day 3 with outcome  $\mathcal{L}$  in canonical form. Given two sets of sets  $A$  and  $B$ , we use the notation  $A \uplus B$  to denote the set  $\{a \cup b | a \in A, b \in B\}$ .

**Theorem 4.63** *A dicot game  $G$  born by day 3 with outcome  $\mathcal{L}$  is in canonical form if and only if either*

$$\left\{ \begin{array}{l} G^L \in (\{\{*\}, \{\alpha\}, \{*, \alpha\}\} \uplus \{\emptyset, \{0\}, \{\bar{\alpha}\}, \{*2\}, \{\bar{\alpha}, *2\}\}) \\ \quad \cup \{\{s\}, \{\bar{\alpha}, s\}, \{\alpha, \bar{s}\}, \{*, \bar{z}\}, \{s, 0\}, \{*, \bar{\alpha}, \bar{z}\}\}, \text{ and} \\ G^R \in \{\{0\}, \{\alpha\}, \{0, \alpha\}, \{0, *2\}, \{\alpha, *2\}, \{0, \alpha, *2\}, \{\bar{z}\}, \{\alpha, z\}, \{0, s\}\}, \end{array} \right.$$

or

$$\left\{ \begin{array}{l} G^L \in \{\{*\}, \{*, 0\}, \{*, \bar{\alpha}\}\}, \text{ and} \\ G^R \in \{\{*2\}, \{s\}, \{z\}, \{s, z\}\}. \end{array} \right.$$

This yields  $21 \cdot 9 + 3 \cdot 4 = 201$  dicots non equivalent modulo  $\mathcal{D}$ .

**Proof.** Let  $G$  be a dicot game born by day 3 with outcome  $\mathcal{L}$ , in canonical form. By our earlier statement,  $G^L \cap \{*, \alpha, s\} \neq \emptyset$ . By Lemma 4.61, options  $\bar{\alpha}, \bar{s}, z, \bar{z}, *2$  are reversible Left options through  $*$  whenever  $G^L \cap \{0, z\} \neq \emptyset$ . Thus, we have 21 of the 50 antichains remaining for  $G^L$ , namely:

$$\left\{ \begin{array}{l} 15 \text{ containing } \{*\}, \{\alpha\} \text{ or } \{*, \alpha\} \text{ together with } \{0\} \text{ or any subset of } \{\bar{\alpha}, *2\} \\ \{s\}, \{s, 0\} \text{ and } \{s, \bar{\alpha}\}, \\ \{\bar{s}, \alpha\} \\ \{\bar{z}, *\} \text{ and } \{\bar{z}, *, \bar{\alpha}\} \end{array} \right.$$

Now, by Lemma 4.62, options  $*, \alpha, s, \bar{s}, \bar{z}$ , and  $*2$  are reversible through 0 whenever  $G^R \cap \{0, \alpha, \bar{z}\} = \emptyset$ . By Lemma 4.50, these options should then be replaced by  $*$ . Thus the only antichains remaining for  $G^L$  when  $G^R \cap \{0, \alpha, \bar{z}\} = \emptyset$  are  $\{*\}$ ,  $\{*, 0\}$  and  $\{*, \bar{\alpha}\}$ .

Consider now Right options. By our earlier statement,  $G^R \subseteq \{0, \alpha, s, z, \bar{z}, *2\}$ , and no Right option is reversible. Intersecting  $\{0, \alpha, \bar{z}\}$ , we have the antichains:  $\{0\}$ ,  $\{\alpha\}$ ,  $\{0, \alpha\}$ ,  $\{0, *2\}$ ,  $\{\alpha, *2\}$ ,  $\{0, \alpha, *2\}$ ,  $\{\bar{z}\}$ ,  $\{\alpha, z\}$  and  $\{0, s\}$ . Non intersecting  $\{0, \alpha, \bar{z}\}$ , we have  $\{*2\}$ ,  $\{s\}$ ,  $\{z\}$  and  $\{s, z\}$ . Combining these sets, we get the theorem.  $\square$

The dicot games born by day 3 with outcome  $\mathcal{R}$  in canonical form are exactly the conjugates of those with outcome  $\mathcal{L}$ .

Now consider dicot games with outcome  $\mathcal{N}$ . By our earlier statement, we have  $G^L \cap \{*, \alpha, s\} \neq \emptyset$  and  $G^R \cap \{*, \bar{\alpha}, \bar{s}\} \neq \emptyset$ . Note that  $G$  and  $*$  are  $\mathcal{D}$ -incomparable since  $o^-(*) = \mathcal{P}$ . Therefore no option of  $G$  is  $\mathcal{D}$ -reversible through  $*$ . Recall also that by Lemma 4.62, we can recognise dicot games born by day 3 whose outcome is  $\mathcal{N}$  and that may contain  $\mathcal{D}$ -reversible options through 0.

**Theorem 4.64** *A dicot game  $G$  born by day 3 with outcome  $\mathcal{N}$  is in canonical form if and only if either  $G = 0$  or*

$$\text{or } \begin{cases} G^L \in \{ \{*\}, \{\alpha\}, \{*, \alpha\}, \{*, *2\}, \{\alpha, *2\}, \{*, \alpha, *2\} \\ \cup \{ \{s\}, \{\alpha, \bar{s}\}, \{*, \bar{z}\} \}, \text{ and} \\ G^R \in \{ \{0, *\}, \{*, \alpha\}, \{0, *, \alpha\}, \{*, \bar{z}\} \}, \end{cases}$$

$$\text{or } \begin{cases} G^L \in \{ \{0, *\}, \{*, \bar{\alpha}\}, \{0, *, \bar{\alpha}\}, \{*, z\} \}, \text{ and} \\ G^R \in \{ \{*\}, \{\bar{z}\}, \{*, \bar{z}\}, \{*, *2\}, \{\bar{z}, *2\}, \{*, \bar{z}, *2\} \\ \cup \{ \{\bar{s}\}, \{\bar{\alpha}, s\}, \{*, z\} \}, \end{cases}$$

$$\text{or } \begin{cases} G^L \in \{ \{*\}, \{\alpha\}, \{*, \alpha\} \} \uplus \{ \{0\}, \{\bar{\alpha}\}, \{0, \bar{\alpha}\} \} \uplus \{ \emptyset, \{*2\} \} \\ \cup \{ \{s, z\}, \{s, 0\}, \{s, \bar{\alpha}\}, \{s, \bar{\alpha}, 0\}, \{z, *\}, \{z, \alpha\}, \{z, \alpha, *\} \} \\ \cup \{ \{\alpha, \bar{s}, 0\}, \{*, \bar{z}, \bar{\alpha}\} \}, \text{ and} \\ G^R \in \{ \{*\}, \{\bar{\alpha}\}, \{*, \bar{\alpha}\} \} \uplus \{ \{0\}, \{\alpha\}, \{0, \alpha\} \} \uplus \{ \emptyset, \{*2\} \} \\ \cup \{ \{\bar{s}, \bar{z}\}, \{\bar{s}, 0\}, \{\bar{s}, \alpha\}, \{\bar{s}, \alpha, 0\}, \{\bar{z}, *\}, \{\bar{z}, \bar{\alpha}\}, \{\bar{z}, \bar{\alpha}, *\} \} \\ \cup \{ \{\bar{\alpha}, s, 0\}, \{*, z, \alpha\} \}. \end{cases}$$

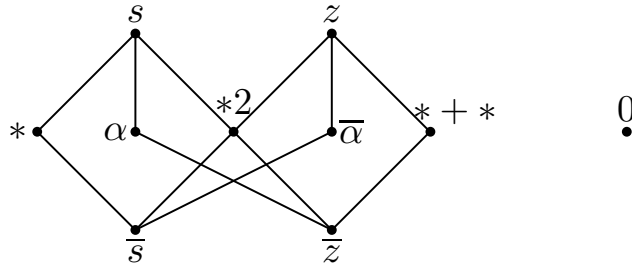
This yields  $1 + 9 \cdot 4 + 4 \cdot 9 + 27 \cdot 27 = 802$  dicots non equivalent modulo  $\mathcal{D}$ .

**Proof.** Recall that by Lemma 4.62, if  $G^R \cap \{0, \alpha, \bar{z}\} = \emptyset$ , then Left options  $*, \alpha, s, \bar{s}, \bar{z}, *2$  are reversible through 0 and get replaced by  $*$ . Similarly, if  $G^L \cap \{0, \bar{\alpha}, z\} = \emptyset$ , then Right options  $*, \bar{\alpha}, s, \bar{s}, z, *2$  are reversible through 0 and get replaced by  $*$ .

Consider first the case when  $G^R \cap \{0, \alpha, \bar{z}\} = \emptyset$  and  $G^L \cap \{0, \bar{\alpha}, z\} = \emptyset$ . Then  $G^L \cap \{\alpha, s, \bar{s}, \bar{z}, *2\} = \emptyset$  and  $G^R \cap \{\bar{\alpha}, s, \bar{s}, z, *2\} = \emptyset$ . So  $G = 0$  or  $\{*\}$  which reduces to 0.

Now, suppose  $G^R \cap \{0, \alpha, \bar{z}\} \neq \emptyset$  but  $G^L \cap \{0, \bar{\alpha}, z\} = \emptyset$ . Then  $G^R \cap \{\bar{\alpha}, s, \bar{s}, z, *2\} = \emptyset$ . Recall that since  $o^-(G) = \mathcal{N}$ ,  $G^R \cap \{*, \bar{\alpha}, \bar{s}\} \neq \emptyset$ . So  $G^R \in \{ \{0, *\}, \{*, \alpha\}, \{0, *, \alpha\}, \{*, \bar{z}\} \}$ . On the other hand,  $G^L$  can be any antichain containing one of  $\{*, \alpha, s\}$  and possibly some of  $\{\bar{s}, \bar{z}, *2\}$ . Thus  $G^L \in \{ \{*\}, \{\alpha\}, \{*, \alpha\}, \{*, *2\}, \{\alpha, *2\}, \{*, \alpha, *2\}, \{s\}, \{\alpha, \bar{s}\}, \{*, \bar{z}\} \}$ . When  $G^L \cap \{0, \bar{\alpha}, z\} \neq \emptyset$  and  $G^R \cap \{0, \alpha, \bar{z}\} = \emptyset$ , we get  $G^L$  and  $G^R$  by conjugating the previous  $G^R$  and  $G^L$  respectively.

Finally, when  $G^R \cap \{0, \alpha, \bar{z}\} \neq \emptyset$  and  $G^L \cap \{0, \bar{\alpha}, z\} \neq \emptyset$ , no option is reversible. Therefore, the antichains for  $G^R$  are those containing at least one



**Figure 4.14:** Partial ordering of dicot games born by day 2 in the general universe

of  $\{0, \alpha, \bar{z}\}$  and one of  $\{*, \bar{\alpha}, \bar{s}\}$ . There are 27 of them, namely:

$$\left\{ \begin{array}{l} 18 \text{ containing some subset of } \{*, \alpha\}, \text{ some subset of } \{0, \bar{\alpha}\} \text{ and possibly } \{*2\} \\ \{s, z\} \\ \{0, s\}, \{\bar{\alpha}, s\} \text{ and } \{0, \bar{\alpha}, s\}, \\ \{*, z\}, \{\alpha, z\} \text{ and } \{*, \alpha, z\}, \\ \{0, \alpha, \bar{s}\} \\ \{*, \bar{\alpha}, \bar{z}\} \end{array} \right.$$

The antichains for  $G^L$  are the conjugates of the antichains for  $G^R$ . □

Adding the number of games with outcome  $\mathcal{P}$ ,  $\mathcal{L}$ ,  $\mathcal{R}$ , and  $\mathcal{N}$ , we get:

**Theorem 4.65** *There are 1268 dicots born by day 3 non equivalent modulo  $\mathcal{D}$ .*

### 4.2.3.1 Dicot games born by day 3 in the general universe

Comparing the number of dicot games born by day 3 in canonical form to the number of games born by day 3 in canonical form is not that relevant, as there are only 1046530 game trees of depth 3 representing dicot games, which is far from the  $2^{1024}$  game trees representing all games born by day 3, or even the (slightly less than)  $2^{183}$  with no dominated option. This is why we count the number of dicot games born by day 3 in their general canonical form modulo the universe of all games.

Recall that a game is in canonical form if and only if all its options are in canonical form and it has no dominated option nor reversible option.

We first recall a result from [38].

**Theorem 4.66** *If  $H$  is a Left end and  $G$  is not, then  $G \not\prec^- H$ .*

This gives us the following corollary, when we only consider dicot games.

**Corollary 4.67** *If  $G$  is a dicot game which is not 0, then  $G$  and 0 are incomparable.*

**Proposition 4.68** *There are 10 dicot games born by day 2 distinguishable modulo the universe of all games, namely  $0, *, * + * = \{*\}$ ,  $\bar{\alpha} = \{0|\ast\}$ ,  $\alpha = \{\ast|0\}$ ,  $s = \{0,\ast|0\}$ ,  $z = \{0,\ast|\ast\}$ ,  $\bar{s} = \{0|0,\ast\}$ ,  $\bar{z} = \{\ast|0,\ast\}$ , and  $\ast 2 = \{0,\ast|0,\ast\}$ . They are partially ordered according to Figure 4.14.*

**Proof.** The proof is similar to the proof of Proposition 4.58. □

We now start counting the dicot games born by day 3. Their Left and Right options are necessarily dicot games born by day 2. We can consider only games in their canonical form, so with no dominated option.

Using Figure 4.14, we find the following 100 antichains:

$$\left\{ \begin{array}{l} \text{all 64 subsets of } \{0, * + *, *, \bar{\alpha}, \alpha, \ast 2\}, \\ \{s, z\}, \{0, s, z\}, \{\bar{s}, \bar{z}\} \text{ and } \{0, \bar{s}, \bar{z}\}, \\ 8 \text{ containing } s \text{ and any subset of } \{0, * + *, \bar{\alpha}\} \\ 8 \text{ containing } z \text{ and any subset of } \{0, *, \alpha\} \\ 8 \text{ containing } \bar{s} \text{ and any subset of } \{0, * + *, \alpha\} \\ 8 \text{ containing } \bar{z} \text{ and any subset of } \{0, *, \bar{\alpha}\} \end{array} \right.$$

Therefore, choosing  $G^L$  and  $G^R$  among these antichains, together with the fact that  $G$  is dicot, we get  $99^2 + 1 = 9802$  dicot games born by day 3 with no dominated option.

To get only games in canonical form, we still have to remove games with reversible options. Note that an option from a dicot game born by day 3 can only be reversible through 0 or  $*$  since these are the only dicot games born by day 1. As no dicot game is comparable with 0, no option can be reversible through 0. Note that as  $o^-(*) = \mathcal{P}$ , no game with outcome  $\mathcal{N}$  may have a reversible option through  $*$ , and no game with outcome  $\mathcal{R}$  may have a Left option reversible through  $*$ . Again, if Left has a winning move from a game  $G$ , namely a move to  $*$ ,  $\alpha$  or  $s$ , or if she has no move from  $G$ , then  $o^-(G) \geq \mathcal{N}$ . Otherwise,  $o^-(G) \leq \mathcal{P}$ . Likewise, if Right has a winning move from  $G$ , namely a move to  $*$ ,  $\bar{\alpha}$  or  $\bar{s}$ , or if he has no move from  $G$ , then  $o^-(G) \leq \mathcal{N}$ . Otherwise,  $o^-(G) \geq \mathcal{P}$ .

We now characterise dicot games having reversible options.

**Lemma 4.69** *Let  $G$  be a dicot game born by day 3 with misère outcome  $\mathcal{P}$  or  $\mathcal{L}$ . We have  $G \geq^- *$  if and only if  $0 \in G^L$ .*

**Proof.** First suppose  $0 \in G^L$ . Let  $X$  be a game such that Left has a winning strategy on  $* + X$  when playing first (respectively second). Left can follow the same strategy on  $G + X$ , unless the strategy recommends that she plays from some  $* + Y$  to  $0 + Y$ , or Right eventually plays from some  $G + Z$  to some  $G^R + Z$ . In the first case, she can just play from  $G + Y$  to  $0 + Y$ . Suppose now that Right just moved from  $G + Z$  to some  $G^R + Z$ . By our choice of strategy, we have  $o^-(* + Z) \geq \mathcal{P}$ . If  $G^R = 0$ , then Left can continue



her strategy since  $0 + Z$  is also a Right option of  $* + Z$ . Otherwise, since  $G^R \cap \{*, \bar{\alpha}, \bar{s}\} = \emptyset$ ,  $G^R$  is one of  $* + *, \alpha, s, z, \bar{z}, *2$  and  $*$  is a Left option of  $G^R$ . Then Left can play from  $G^R + Z$  to  $* + Z$  and win. Thus, if Left wins  $* + X$ , she wins  $G + X$  as well and thus  $G \geq^- *$ .

Assume now  $0 \notin G^L$ . Let  $X = \{\cdot|\cdot|3\}$ . In  $* + X$ , Left wins by moving to  $X$ , so  $o^-(* + X) \geq \mathcal{N}$ . On the other hand, in  $G + X$ , Left has to move to some  $G^L + X$ , where  $G^L$  is a non-zero dicot. Then Right can move to  $G^L + \{\cdot|3\}$ , where Left has to play in  $G^L$ , to  $G^{LL} + \{\cdot|3\}$ , where  $G^{LL}$  is a dicot born by day 1. Right's move to  $G^{LL} + 3$  is then a winning move. hence  $o^-(G + X) \leq \mathcal{P}$ , and we have  $G \not\geq^- *$ .  $\square$

We now are in position to state the set of dicot games born by day 3 in canonical form (modulo the universe of all games) with any outcome.

**Theorem 4.70** *A dicot game  $G$  born by day 3 with outcome  $\mathcal{P}$  is in canonical form if and only if*

$$\left\{ \begin{array}{l} G^L \in \{ \{ * + *, \{\bar{\alpha}\}, \{ *2 \}, \{ * + *, \bar{\alpha} \}, \{ * + *, *2 \}, \{ \bar{\alpha}, *2 \}, \{ * + *, \bar{\alpha}, *2 \} \\ \cup \{ \{ 0 \}, \{ \bar{s}, \bar{z} \}, \{ z \}, \{ \bar{s} \}, \{ \bar{s}, * + * \}, \{ \bar{z} \}, \{ \bar{z}, \bar{\alpha} \} \} \\ G^R \in \{ \{ * + *, \{ \alpha \}, \{ *2 \}, \{ * + *, \alpha \}, \{ * + *, *2 \}, \{ \alpha, *2 \}, \{ * + *, \alpha, *2 \} \\ \cup \{ \{ 0 \}, \{ s, z \}, \{ \bar{z} \}, \{ s \}, \{ s, * + * \}, \{ z \}, \{ \bar{z}, \alpha \} \} \end{array} \right.$$

*This yields  $14 \cdot 14 = 196$  non-equivalent dicot games.*

**Theorem 4.71** *A dicot game  $G$  born by day 3 with outcome  $\mathcal{L}$  is in canonical form if and only if*

$$\left\{ \begin{array}{l} G^L \in \{ \{ * \}, \{ \alpha \}, \{ *, \alpha \} \} \uplus \{ \{ * + *, \{\bar{\alpha}\}, \{ * + *, \bar{\alpha} \} \} \uplus \{ \emptyset, \{ *2 \} \} \\ \cup \{ \{ s, z \}, \{ s, * + * \}, \{ s, \bar{\alpha} \}, \{ s, \bar{\alpha}, * + * \}, \{ z, * \}, \{ z, \alpha \}, \{ z, \alpha, * \} \} \\ \cup \{ \{ \alpha, \bar{s}, * + * \}, \{ *, \bar{z}, \bar{\alpha} \}, \{ s \}, \{ \alpha, \bar{s} \}, \{ *, \bar{z} \} \} \\ \cup \{ \{ * \}, \{ \alpha \}, \{ *, \alpha \}, \{ *, *2 \}, \{ \alpha, *2 \}, \{ *, \alpha, *2 \} \} \\ \cup \{ \{ 0, * \}, \{ 0, \alpha \}, \{ 0, *, \alpha \}, \{ 0, s \} \}, \text{ and} \\ G^R \in \{ \{ * + *, \{ \alpha \}, \{ *2 \}, \{ * + *, \alpha \}, \{ * + *, *2 \}, \{ \alpha, *2 \}, \{ * + *, \alpha, *2 \} \} \\ \cup \{ \{ s, z \}, \{ \bar{z} \}, \{ s \}, \{ s, * + * \}, \{ z \}, \{ z, \alpha \}, \{ 0 \}, \{ 0, * + * \}, \{ 0, \alpha \} \} \\ \cup \{ \{ 0, *2 \}, \{ 0, * + *, \alpha \}, \{ 0, * + *, *2 \}, \{ 0, \alpha, *2 \}, \{ 0, * + *, \alpha, *2 \} \} \\ \cup \{ \{ 0, s, z \}, \{ 0, \bar{z} \}, \{ 0, s \}, \{ 0, s, * + * \}, \{ 0, z \}, \{ 0, z, \alpha \} \} \end{array} \right.$$

*This yields  $40 \cdot 27 = 1080$  non-equivalent dicot games.*

The dicot games born by day 3 with outcome  $\mathcal{R}$  in canonical form are exactly the conjugates of those with outcome  $\mathcal{L}$ .

**Theorem 4.72** *A dicot game  $G$  born by day 3 with outcome  $\mathcal{N}$  is in canon-*

ical form if and only if either  $G = 0$  or

$$\left\{ \begin{array}{l} G^L \in \{ \{*\}, \{\alpha\}, \{*, \alpha\} \} \uplus \{ \{* + *\}, \{\bar{\alpha}\}, \{* + *, \bar{\alpha}\} \} \uplus \{ \emptyset, \{*2\} \} \\ \cup \{ \{s, z\}, \{s, * + *\}, \{s, \bar{\alpha}\}, \{s, \bar{\alpha}, * + *\}, \{z, *\}, \{z, \alpha\}, \{z, \alpha, *\} \} \\ \cup \{ \{\alpha, \bar{s}, * + *\}, \{*, \bar{z}, \bar{\alpha}\}, \{s\}, \{\alpha, \bar{s}\}, \{*, \bar{z}\} \} \\ \cup \{ \{*\}, \{\alpha\}, \{*, \alpha\}, \{*, *2\}, \{\alpha, *2\}, \{*, \alpha, *2\} \} \\ \cup \{ \{*\}, \{\alpha\}, \{*, \alpha\} \} \uplus \{ \{* + *\}, \{\bar{\alpha}\}, \{* + *, \bar{\alpha}\} \} \uplus \{ \{0\}, \{0, *2\} \} \\ \cup \{ \{0, s, z\}, \{0, s, * + *\}, \{0, s, \bar{\alpha}\}, \{0, s, \bar{\alpha}, * + *\} \} \\ \cup \{ \{0, z, *\}, \{0, z, \alpha\}, \{0, z, \alpha, *\} \} \\ \cup \{ \{0, \alpha, \bar{s}, * + *\}, \{0, *, \bar{z}, \bar{\alpha}\}, \{0, s\}, \{0, \alpha, \bar{s}\}, \{0, *, \bar{z}\} \} \\ \cup \{ \{0, *\}, \{0, \alpha\}, \{0, *, \alpha\}, \{0, *, *2\}, \{0, \alpha, *2\}, \{0, *, \alpha, *2\} \} \\ G^R \in \{ \{*\}, \{\bar{\alpha}\}, \{*, \bar{\alpha}\} \} \uplus \{ \{* + *\}, \{\alpha\}, \{* + *, \alpha\} \} \uplus \{ \emptyset, \{*2\} \} \\ \cup \{ \{\bar{s}, \bar{z}\}, \{\bar{s}, * + *\}, \{\bar{s}, \alpha\}, \{\bar{s}, \alpha, * + *\}, \{\bar{z}, *\}, \{\bar{z}, \bar{\alpha}\}, \{\bar{z}, \bar{\alpha}, *\} \} \\ \cup \{ \{\bar{\alpha}, s, * + *\}, \{*, z, \alpha\}, \{\bar{s}\}, \{\bar{\alpha}, s\}, \{*, z\} \} \\ \cup \{ \{*\}, \{\bar{\alpha}\}, \{*, \bar{\alpha}\}, \{*, *2\}, \{\bar{\alpha}, *2\}, \{*, \bar{\alpha}, *2\} \} \\ \cup \{ \{*\}, \{\bar{\alpha}\}, \{*, \bar{\alpha}\} \} \uplus \{ \{* + *\}, \{\alpha\}, \{* + *, \alpha\} \} \uplus \{ \{0\}, \{0, *2\} \} \\ \cup \{ \{0, \bar{s}, \bar{z}\}, \{0, \bar{s}, * + *\}, \{0, \bar{s}, \alpha\}, \{0, \bar{s}, \alpha, * + *\} \} \\ \cup \{ \{0, \bar{z}, *\}, \{0, \bar{z}, \bar{\alpha}\}, \{0, \bar{z}, \bar{\alpha}, *\} \} \\ \cup \{ \{0, \bar{\alpha}, s, * + *\}, \{0, *, z, \alpha\}, \{0, \bar{s}\}, \{0, \bar{\alpha}, s\}, \{0, *, z\} \} \\ \cup \{ \{0, *\}, \{0, \bar{\alpha}\}, \{0, *, \bar{\alpha}\}, \{0, *, *2\}, \{0, \bar{\alpha}, *2\}, \{0, *, \bar{\alpha}, *2\} \} \end{array} \right.$$

This yields  $72 \cdot 72 + 1 = 5185$  non-equivalent dicot games.

Adding the numbers of games with outcome  $\mathcal{P}$ ,  $\mathcal{L}$ ,  $\mathcal{R}$  and  $\mathcal{N}$ , we get:

**Theorem 4.73** *There are 7541 non-equivalent dicot games born by day 3.*
















#### 4.2.4 Sums of dicots can have any outcome

In the previous subsection, we proved that modulo the universe of dicots, there were much fewer distinguishable dicot games under misère convention. A natural question that arises is whether in this setting, one could sometimes deduce from the outcomes of two games the outcome of their sum. This occurs in normal convention in particular with games with outcome  $\mathcal{P}$ . In this subsection, we show that this is not possible with dicots. We first prove that the misère outcome of a dicot is not related to its normal outcome.

**Theorem 4.74** *Let  $\mathcal{A}, \mathcal{B}$  be any outcomes in  $\{\mathcal{P}, \mathcal{L}, \mathcal{R}, \mathcal{N}\}$ . There exists a dicot  $G$  with normal outcome  $o^+(G) = \mathcal{A}$  and misère outcome  $o^-(G) = \mathcal{B}$ .*

**Proof.** In Figure 4.15, we give for any  $\mathcal{A}, \mathcal{B} \in \{\mathcal{P}, \mathcal{L}, \mathcal{R}, \mathcal{N}\}$  a dicot  $G$  such that  $o^+(G) = \mathcal{A}$  and  $o^-(G) = \mathcal{B}$ .  $\square$

**Theorem 4.75** *Let  $\mathcal{A}, \mathcal{B}$  and  $\mathcal{C}$  be any outcomes in  $\{\mathcal{P}, \mathcal{L}, \mathcal{R}, \mathcal{N}\}$ . There exist two dicots  $G_1$  and  $G_2$  such that  $o^-(G_1) = \mathcal{A}$ ,  $o^-(G_2) = \mathcal{B}$  and  $o^-(G_1 + G_2) = \mathcal{C}$ .*

Normal $\rightarrow$ Misère $\downarrow$	$\mathcal{P}$	$\mathcal{L}$	$\mathcal{R}$	$\mathcal{N}$
$\mathcal{P}$				
$\mathcal{L}$				
$\mathcal{R}$				
$\mathcal{N}$	.			

**Figure 4.15:** Normal and misère outcomes of some dicots

**Proof.** In Figure 4.16, we give for any  $\mathcal{A}, \mathcal{B}, \mathcal{C} \in \{\mathcal{P}, \mathcal{L}, \mathcal{R}, \mathcal{N}\}$  two games  $G_1$  and  $G_2$  such that  $o^-(G_1) = \mathcal{A}$ ,  $o^-(G_2) = \mathcal{B}$  and  $o^-(G_1 + G_2) = \mathcal{C}$ .  $\square$

### 4.3 A peek at the dead-ending universe

In many combinatorial games, players place pieces on a board according to some set of rules. Usually, these rules imply that the board space available to a player at their turn are a subset of those available on the previous turn. Among games fitting that description, we can mention COL, DOMINEERING, HEX, or SNORT. One can also see it as a board where pieces are removed, with rules implying that the set of pieces removable is decreasing after each turn. Among games fitting that description, we can mention HACKENBUSH, NIM or any octal game, or TIMBUSH. A property all these games share in contrast with PARTIZAN PEG DUOTAIRE or FLIP THE COIN is that no player can ‘open up’ moves for themselves or for their opponent; in particular, a player who has no available move at some position will not be able to play for the rest of the game. This is the property we call dead-ending.

We recall the more formal definition of dead-ending: A Left (Right) end is a *dead end* if every follower is also a Left (Right) end. A game is said to be *dead-ending* if all its end followers are dead ends.

Note that dicot games, studied in Section 4.2, are all dead-ending, as the only end follower of a dicot is 0, which is a dead end.

**Example 4.76** Figure 4.17 gives three examples of games that are dead-ending. The first game is a dead end. The second game is dead-ending as its end followers are either 0 or  $\bar{1}$ , which are both dead ends. The third game is

	$\mathcal{P}$		$\mathcal{L}$	
	$\mathcal{R}$		$\mathcal{N}$	
$\mathcal{P} + \mathcal{P}$ :				
$\mathcal{P} + \mathcal{L}$ :				
$\mathcal{P} + \mathcal{N}$ :				
$\mathcal{L} + \mathcal{L}$ :				
$\mathcal{L} + \mathcal{R}$ :				
$\mathcal{L} + \mathcal{N}$ :				
$\mathcal{N} + \mathcal{N}$ :				

Figure 4.16: Sums of dicots can have any outcome

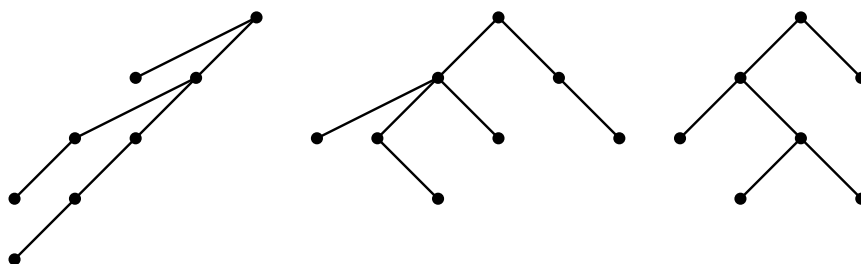


Figure 4.17: Some dead-ending positions

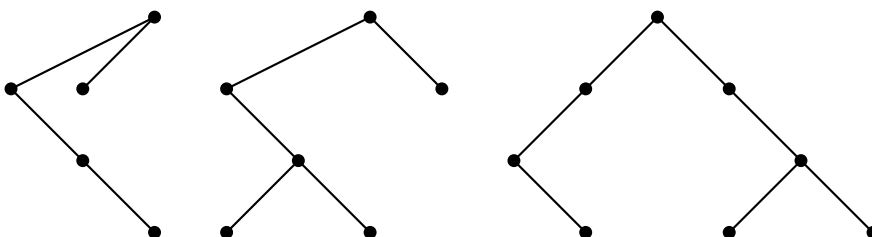


Figure 4.18: Some positions that are not dead-ending

a dicot game, hence a dead-ending game. Figure 4.18 gives three examples of games that are not dead-ending. The first game is a Right end that is not a dead end as Right can move from one of Left's options. The second game is not dead-ending because its Left option is a Left end that is not a dead end. The third game is not dead-ending because both its Left option and its Right option are ends that are not dead ends.

In the following, we look at numbers under their normal canonical form. Since, among other shortcomings,  $\mathbf{1} \not\prec_{\mathcal{E}} \mathbf{2}$  or  $\frac{1}{2} + \frac{1}{2} \not\equiv_{\mathcal{E}} \mathbf{1}$  as games, to avoid confusion, we distinguish between the game  $\mathbf{a}$  and the number  $a$ . For the rest of this section, we use the notation  $\mathbf{0}$  for the game  $\{\cdot|\cdot\}$  too.

In this section, we find the misère monoid of dead ends, the misère monoid of normal-play canonical form numbers, give their partial order modulo the dead-ending universe and discuss other dead-ending games, in the context of equivalency to zero modulo the universe of dead-ending games.

### 4.3.1 Preliminary results

We start by proving the closure of the dead-ending universe under the three aspects we mentioned in the introduction of this chapter: it is closed under followers, closed under disjunctive sum, and closed under conjugates.

**Lemma 4.77** *If  $G$  is dead-ending then every follower of  $G$  is dead-ending.*

**Proof.** If  $H$  is a follower of  $G$ , then every follower of  $H$  is also a follower of  $G$ ; thus if  $G$  satisfies the definition of dead-ending, then so does  $H$ .  $\square$

**Lemma 4.78** *If  $G$  and  $H$  are dead-ending then  $G + H$  is dead-ending.*

**Proof.** Any follower of  $G + H$  is of the form  $G' + H'$  where  $G'$  and  $H'$  are (not necessarily proper) followers of  $G$  and  $H$ , respectively. If  $G' + H'$  is a Left end, then both  $G'$  and  $H'$  are Left ends, which must be dead, since  $G$  and  $H$  are dead-ending. Thus, any followers  $G''$  and  $H''$  are Left ends, and so all followers  $G'' + H''$  of  $G' + H'$  are Left ends. A symmetric argument holds if  $G' + H'$  is a Right end, and so  $G + H$  is dead-ending.  $\square$

**Lemma 4.79** *If  $G$  is dead-ending, then  $\overline{G}$  is dead-ending.*

**Proof.** Any follower of  $\overline{G}$  is the conjugate of a follower of  $G$ . If  $H$  is an end, so is  $\overline{H}$ , hence assuming  $H$  is a follower of  $\overline{G}$ ,  $\overline{H}$  is a dead end, and so is  $H$ .  $\square$

Under misère play, Left wins any Left end playing first as she already has no move. In a general context, she might lose playing second, for example in the game  $\{\cdot | *\}$ , which is both a Left end and a misère  $\mathcal{N}$ -position. In the dead-ending universe, however, Left wins any non-zero Left end playing first or second.

**Lemma 4.80** *If  $G \neq \mathbf{0}$  is a dead Left end then  $G \in \mathcal{L}^-$ , and if  $G \neq \mathbf{0}$  is a dead Right end then  $G \in \mathcal{R}^-$ .*

**Proof.** A Left end is always in  $\mathcal{L}^-$  or  $\mathcal{N}^-$ . If  $G$  is a dead Left end then any Right option  $G^R$  is also a Left end, so Right has no good first move. Similarly, a dead Right end is in  $\mathcal{R}^-$ .  $\square$

In the following of this section, we refer to two game functions defined below, which are well-defined for our purpose, namely for numbers and ends.

**Definition 4.81** The left-length of a game  $G$ , denoted  $l(G)$ , is the minimum number of consecutive Left moves required for Left to reach zero in  $G$ . The right-length  $r(G)$  of  $G$  is the minimum number of consecutive Right moves required for Right to reach zero in  $G$ .

In general, the left- and right-length are well-defined if  $G$  has a non-alternating path to zero for Left or Right, respectively, and if the shortest of such paths is never dominated by another option. The latter condition ensures  $l(G) = l(G')$  when  $G \equiv^- G'$ . As suggested above, both of these conditions are met if  $G$  is a (normal-play) canonical-form number or if  $G$  is an end in  $\mathcal{E}$ . If  $l(G)$  and  $l(H)$  are both well-defined then  $l(G + H)$  is defined and  $l(G + H) = l(G) + l(H)$ . Similarly, when the right-length is defined for  $G$  and  $H$ , we have  $r(G + H) = r(G) + r(H)$ .

It would be possible to extend these functions to all games by replacing “zero” by “a Left end” for the left-length, and by “a Right end” for the right-length, but we want to insist here that in the cases we use it, the end we reach is zero.

### 4.3.2 Integers and other dead ends

We first look at dead ends, with some focus on integers.

Recall that  $\mathbf{n}$  denote the game  $\{\mathbf{n} - \mathbf{1}|\cdot\}$  when  $n$  is positive, where  $\mathbf{0} = \{\cdot|\cdot\}$ . Considering two positive integers  $n$  and  $m$ , their disjunctive sum has the same game tree as the integer  $\mathbf{n} + \mathbf{m}$ . This is not true if  $n$  is negative and  $m$  positive, and the two games (the disjunctive sum and the integer) are not even equivalent in general misère play.

Any integer is an example of a dead end: if  $n > 0$ , then Right has no move in  $\mathbf{n}$ , and we inductively see that he has no move in any follower of  $\mathbf{n}$ ; similarly, if  $n < 0$ , then  $\mathbf{n}$  is a dead Left end. Thus, the following results for ends in the dead-ending universe are also true for all integers, modulo  $\mathcal{E}$ .

Our first result shows that when all games in a sum are dead ends, the outcome is completely determined by the left- and right-lengths of the games. As a sum of Left ends is a Left end and a sum of Right ends is a Right end, we only consider two games in a sum of ends, one being a Left end and the other a Right end.

**Lemma 4.82** *If  $G$  is a dead Right end and  $H$  is a dead Left end then*

$$o^-(G + H) = \begin{cases} \mathcal{N}^- & \text{if } l(G) = r(H) \\ \mathcal{L}^- & \text{if } l(G) < r(H) \\ \mathcal{R}^- & \text{if } l(G) > r(H) \end{cases}$$

**Proof.** Each player has no choice but to play in their own game, and so the winner will be the player who can run out of moves first.  $\square$

We use Lemma 4.82 to prove the following theorem, which demonstrates the invertibility of all ends modulo  $\mathcal{E}$ , even giving the corresponding inverse.

**Theorem 4.83** *If  $G$  is a dead end, then  $G + \overline{G} \equiv_{\mathcal{E}} \mathbf{0}$ .*

**Proof.** Assume without loss of generality that  $G \neq \mathbf{0}$  is a dead right end. Since every follower of a dead end is also a dead end, Lemma 4.2 applies, with  $S$  the set of all dead Left and Right ends. It therefore suffices to show  $G + \overline{G} + X \in \mathcal{L}^- \cup \mathcal{N}^-$  for any Left end  $X$  in  $E$ . We have  $l(G) = r(\overline{G})$  and  $r(X) \geq 0$ , so  $l(G) \leq r(G) + r(X) = r(G + X)$ , which gives  $G + \overline{G} + X \in \mathcal{L}^- \cup \mathcal{N}^-$  by Lemma 4.82.  $\square$

We immediately get the following corollary by recalling that integers are dead ends.

**Corollary 4.84** *If  $n$  is an integer, then  $\mathbf{n} + \overline{\mathbf{n}} \equiv_{\mathcal{E}} \mathbf{0}$ .*

This implies the following corollary about any sum of integers.

**Corollary 4.85** *If  $n$  and  $m$  are integers, then  $\mathbf{n} + \mathbf{m} \equiv_{\mathcal{E}} \mathbf{n} + \mathbf{m}$ .*

Recall that equivalency in  $\mathcal{E}$  implies equivalency in all subuniverse of  $\mathcal{E}$ . Thus, in the universe of integers alone, every integer keeps its inverse.

Lemma 4.82 shows that when playing a sum of dead ends, both players aim to exhaust their moves as fast as possible. This suggests that longer paths to zero would be dominated by shorter paths; in particular, this would give a total ordering of integers among dead ends, as established in Theorem 4.86 below. Note that this ordering only holds in the subuniverse of the closure of dead ends, that is the universe of sums of dead ends, and not in the whole universe  $\mathcal{E}$ . Actually, we show right in Theorem 4.87 that distinct integers are incomparable modulo  $\mathcal{E}$ , just as they are in the general misère universe.

**Theorem 4.86** *If  $n < m \in \mathbb{Z}$ , then  $\mathbf{n} >^- \mathbf{m}$  modulo the closure of dead ends.*

**Proof.** By Corollary 4.84, it suffices to show  $\mathbf{n} + \overline{\mathbf{m}} >^- \mathbf{0}$  (equivalently,  $\mathbf{k} > \mathbf{0}$  for any negative integer  $k$ ), modulo the closure of dead ends. Let  $X$  be any game in the closure of dead ends; then  $X = Y + Z$  where  $Y$  is a dead Right end and  $Z$  is a dead Left end. Suppose Left wins  $X$  playing first; then by Lemma 4.82,  $l(Y) \leq r(Z)$ . We need to show Left wins  $k + X$ , so that  $o^-(k + X) \geq o^-(X)$ . Since  $k$  is a negative integer,  $r(\mathbf{k})$  is defined and  $r(\mathbf{k}) = -k > 0$ . Thus  $l(Y) \leq r(Z) < r(Z) + r(\mathbf{k}) = r(Z + \mathbf{k})$ , which gives  $\mathbf{k} + Y + Z = \mathbf{k} + X \in \mathcal{L}^- \cup \mathcal{N}^-$ , by Lemma 4.82.  $\square$

In general, an inequality under misère play between games implies the same inequality under normal play between the same games [38]. This is also true for some specific universes, as we have seen with the dicot universe in Section 4.2. Theorem 4.86 shows this is not always true for any universe.

We now show that integers, despite being totally ordered in the closure of dead ends, are pairwise incomparable in the dead-ending universe.

**Theorem 4.87** *If  $n \neq m \in \mathbb{Z}$ , then  $\mathbf{n} \parallel_{\mathcal{E}}^- \mathbf{m}$ .*

**Proof.** Assume  $n > m$ .

Define two families of games  $\alpha_k$  and  $\beta_k$  by

$$\alpha_1 = \{\mathbf{0}|\mathbf{0}\}; \alpha_k = \{\mathbf{0}|\alpha_{k-1}\}; \beta_k = \{\overline{\alpha_k}|\alpha_k\}.$$

Note that  $o^-(\beta_k) = \mathcal{N}$  and  $o^-(\mathbf{k} + \beta_k) = \mathcal{P}$  for all positive  $k$ . Thus  $\mathbf{m} + \overline{\mathbf{m}} + \beta_{n-m} \equiv_{\mathcal{E}}^- \beta_{n-m} \in \mathcal{N}^-$  and



$\mathbf{n} + \overline{\mathbf{m}} + \beta_{n-m} \equiv_{\mathcal{E}^-} \mathbf{n-m} + \beta_{n-m} \in \mathcal{P}^-$ , and  $\overline{\mathbf{m}} + \beta_{n-m}$  witnesses both  $\mathbf{n} \not\leq_{\mathcal{E}^-} \mathbf{m}$  and  $\mathbf{n} \not\leq_{\mathcal{E}^-} \mathbf{m}$ .  $\square$

As integers are pairwise incomparable, a dead end having several options might have no  $\mathcal{E}$ -dominated option. Thus, in the dead-ending universe, there exists ends that are not integers. However, when restricting ourselves to the subuniverse of the closure of dead ends, the ordering given by theorem 4.86 implies that every end reduces to an integer. This fact is presented in the following lemma.

**Lemma 4.88** *If  $G$  is a dead end then  $G \equiv^- \mathbf{n}$  modulo the closure of dead ends, where  $n = l(G)$  if  $G$  is a Right end and  $n = -r(G)$  if  $G$  is a Left end.*

**Proof.** Let  $G$  be a dead Right end (the argument for Left ends is symmetric). Assume by induction that every option  $G^{L_i}$  of  $G$  (necessarily a dead Right end) is equivalent to the integer  $l(G^{L_i})$ . Modulo dead ends, by Theorem 4.86, these Left options are totally ordered; thus  $G = \{G^{L_1}|\cdot\}$  for  $G^{L_1}$  with smallest left-length. Then  $G$  is the canonical form of the integer  $l(G^{L_1}) + 1 = l(G)$ .  $\square$

Lemma 4.88 shows that the closure of dead ends has precisely the same misère monoid as the closure of integers. The game of DOMINEERING on  $1 \times n$  and  $n \times 1$  board is an instance of these universes. We are now able to completely describe the misère monoid of the closure of dead ends, which we present in Theorem 4.89.

**Theorem 4.89** *Under the mapping*

$$G \mapsto \begin{cases} \alpha^{l(G)} & \text{if } G \text{ is a Right end} \\ \alpha^{-r(G)} & \text{if } G \text{ is a Left end} \end{cases},$$

*the misère monoid of the closure of dead ends is*

$$\mathcal{M}_{\mathbb{Z}} = \langle 1, \alpha, \alpha^{-1} \mid \alpha \cdot \alpha^{-1} = 1 \rangle$$

*with outcome partition*

$$\mathcal{N}^- = \{1\}, \mathcal{L}^- = \{\alpha^{-n} \mid n \in \mathbb{N}^*\}, \mathcal{R}^- = \{\alpha^n \mid n \in \mathbb{N}^*\}$$

*and total ordering*

$$\alpha^n > \alpha^m \Leftrightarrow n < m.$$

### 4.3.3 Numbers

#### 4.3.3.1 The misère monoid of $\mathcal{Q}_2$

We now look at all numbers under their normal canonical form.

We say a game  $\mathbf{a}$  is a *non-integer number* if it is the normal-play canonical form of a (non-integer) dyadic rational, that is

$$\mathbf{a} = \frac{2*m+1}{2^k} = \left\{ \frac{2*m}{2^k} \mid \frac{2*m+2}{2^k} \right\},$$

with  $k > 0$ . The set of all integer and non-integer (combinatorial game) numbers is thus the set of dyadic rationals, which we denote by  $\mathbb{Q}_2$ . As we did for integers previously, we now determine the outcome of a general sum of dyadic rationals and thereby describe the misère monoid of the closure of numbers.

Note that the sum of two non-integer numbers (even if both are positive) is not necessarily another number. For example,  $\frac{1}{2} + \frac{1}{2} \neq 1$ . We see in the following that, unlike integers, the set of dyadic rationals is not closed under disjunctive sum even when restricted to the dead-ending universe; however, closure does occur when we restrict to numbers alone.

Lemma 4.92 below, analogous to Lemma 4.82 of the previous section, shows that the outcome of a sum of numbers is determined by the left- and right-lengths of the individual numbers. To prove this, we require Lemma 4.91, which establishes a relationship between the left- or right-lengths of numbers and their options; and to prove Lemma 4.91, we need the following proposition.

**Proposition 4.90** *If  $a \in \mathbb{Q}_2 \setminus \mathbb{Z}$  then at least one of  $a^{RL}$  and  $a^{LR}$  exists, and either  $\mathbf{a}^L = \mathbf{a}^{RL}$  or  $\mathbf{a}^R = \mathbf{a}^{LR}$ .*

**Proof.** Let  $\mathbf{a} = \frac{2*m+1}{2^k}$  with  $k > 0$ . If  $m \equiv 0 \pmod{2}$  then

$$\mathbf{a}^L = \frac{2*m}{2^k}; \mathbf{a}^R = \frac{2*m+2}{2^k} = \frac{2*m+2}{2^{k-1}} = \left\{ \frac{2*m}{2^{k-1}} \mid \frac{2*m+4}{2^{k-1}} \right\},$$

so  $\mathbf{a}^L = \mathbf{a}^{RL}$ . Otherwise,  $m \equiv 1 \pmod{2}$  and then

$$\mathbf{a}^L = \frac{2*m}{2^k} = \frac{2*m}{2^{k-1}} = \left\{ \frac{2*m-2}{2^{k-1}} \mid \frac{2*m+2}{2^{k-1}} \right\}; \mathbf{a}^R = \frac{2*m+2}{2^k},$$

so  $\mathbf{a}^R = \mathbf{a}^{LR}$ . □

Note that if  $a > 0$  is a dyadic rational, then  $l(\mathbf{a}) = 1 + l(\mathbf{a}^L)$ , and if  $a < 0$  is a dyadic rational, then  $r(\mathbf{a}) = 1 + r(\mathbf{a}^R)$ . We also have the following inequalities for left-lengths of right options and right-lengths of left options, when  $a$  is a non-integer dyadic rational.

**Lemma 4.91** *If  $a \in \mathbb{Q}_2 \setminus \mathbb{Z}$  is positive, then  $l(\mathbf{a}^R) \leq l(\mathbf{a})$ ; if  $a$  is negative, then  $r(\mathbf{a}^L) \leq r(\mathbf{a})$ .*

**Proof.** Assume  $a > 0$  (the argument for  $a < 0$  is symmetric). Since  $\mathbf{a}$  is in canonical form, both  $\mathbf{a}^L$  and  $\mathbf{a}^R$  are positive numbers. If  $\mathbf{a}^L = \mathbf{a}^{RL}$ , then  $l(\mathbf{a}^R) = 1 + l(\mathbf{a}^{RL}) = 1 + l(\mathbf{a}^L) = l(\mathbf{a})$ . Otherwise  $\mathbf{a}^R = \mathbf{a}^{LR}$ , by Proposition 4.90; then  $\mathbf{a}^L$  is not an integer because  $\mathbf{a}^{LR}$  exists, so by induction we obtain  $l(\mathbf{a}^R) = l(\mathbf{a}^{LR}) \leq l(\mathbf{a}^L) = l(\mathbf{a}) - 1 < l(\mathbf{a})$ .  $\square$

We can now determine the outcome of a general sum of numbers, both integer and non-integer.

**Lemma 4.92** *If  $\{a_i\}_{1 \leq i \leq n}$  and  $\{b_i\}_{1 \leq i \leq m}$  are sets of positive and negative numbers, respectively, with  $k = \sum_{i=1}^n l(\mathbf{a}_i) - \sum_{i=1}^m r(\mathbf{b}_i)$ , then*

$$o^-\left(\sum_{i=1}^n \mathbf{a}_i + \sum_{i=1}^m \mathbf{b}_i\right) = \begin{cases} \mathcal{L}^- & \text{if } k < 0 \\ \mathcal{N}^- & \text{if } k = 0 \\ \mathcal{R}^- & \text{if } k > 0. \end{cases}$$

**Proof.** Let  $G = \sum_{i=1}^n \mathbf{a}_i + \sum_{i=1}^m \mathbf{b}_i$ . All followers of  $G$  are also of this form, so assume the result holds for every proper follower of  $G$ . Suppose  $k < 0$ . If  $n = 0$  then Left will run out of moves first because Left cannot move last in any negative number. So assume  $n > 0$ . Left moving first can move in an  $\mathbf{a}_i$  to reduce  $k$  by one (since  $l(\mathbf{a}_i^L) = l(\mathbf{a}_i) - 1$ ), which is a Left-win position by induction. If Right moves first in an  $\mathbf{a}_i$  then  $k$  does not increase, since  $l(\mathbf{a}_i^R) \leq l(\mathbf{a}_i)$  by Lemma 4.91, so the position is a Left-win by induction; if Right moves first in a  $\mathbf{b}_i$  then  $k$  does increase by one, but Left can respond in an  $\mathbf{a}_i$  (since  $n > 0$ ) to bring  $k$  down again, leaving another Left-win position, by induction. Thus  $G \in \mathcal{L}^-$  if  $k < 0$ .

The argument for  $k > 0$  is symmetric. If  $k = 0$  then either  $G = \mathbf{0}$  is trivially next-win, or both  $n$  and  $m$  are at least 1 and both players have a good first move to change  $k$  in their favour.  $\square$

Lemma 4.92 shows that in general misère play, the outcome of a sum of numbers is completely determined by the left-lengths and right-lengths of the positive and negative components, respectively. From this we can conclude that, modulo the closure of canonical-form numbers, a positive number  $\mathbf{a}$  is equivalent to every other number with left-length  $l(\mathbf{a})$ . In particular, every positive number  $\mathbf{a}$  is equivalent to the integer  $l(\mathbf{a})$ . This is Corollary 4.93 below; together with Theorem 4.96, it will allow us to describe the misère monoid of canonical-form numbers.

**Corollary 4.93** *If  $\mathbf{a}$  is a number, then*

$$a \equiv_{\mathcal{Q}_2}^- \begin{cases} l(\mathbf{a}) & \text{if } a \geq 0 \\ -r(\mathbf{a}) & \text{if } a < 0 \end{cases}$$

As examples, the dyadic rational  $\frac{3}{4}$  is equivalent to  $\mathbf{2}$ , and  $-\frac{11}{8}$  is equivalent to  $-\mathbf{3}$ , modulo  $\mathcal{Q}_2$ . Note that these equivalencies do not hold in the

larger universe  $\mathcal{E}$ , as we see in the following that if  $a \neq b$  are numbers, then  $\mathbf{a} \not\equiv_{\mathcal{E}} \mathbf{b}$ .

We see then that the closure of numbers is isomorphic to the closure of just integers; when restricted to numbers alone, every non-integer is equivalent to an integer. Thus the misère monoid of numbers, given below, is the same monoid presented in Theorem 4.89.

**Theorem 4.94** *Under the mapping*

$$\mathbf{a} \mapsto \begin{cases} \alpha^{l(\mathbf{a})} & \text{if } a \text{ is positive} \\ \alpha^{-r(\mathbf{a})} & \text{if } a \text{ is negative} \end{cases},$$

the misère monoid of the closure of canonical-form dyadic rationals is

$$\mathcal{M}_{\mathbb{Z}} = \langle 1, \alpha, \alpha^{-1} \mid \alpha \cdot \alpha^{-1} = 1 \rangle$$

with outcome partition

$$\mathcal{N}^- = \{1\}, \mathcal{L}^- = \{\alpha^{-n} \mid n \in \mathbb{N}^*\}, \mathcal{R}^- = \{\alpha^n \mid n \in \mathbb{N}^*\}.$$

As with integers, some of the structure found in the number universe is also present in the larger universe  $\mathcal{E}$ . We now give a proof that all numbers, and not just integers, are invertible in the universe of dead-ending games, having their conjugates as inverses. We require the following lemma, an extension of Lemma 4.92.

**Lemma 4.95** *If  $\{a_i\}_{1 \leq i \leq n}$  and  $\{b_i\}_{1 \leq i \leq m}$  are sets of positive and negative numbers, respectively, and  $\sum_{i=1}^n l(\mathbf{a}_i) - \sum_{i=1}^m r(\mathbf{b}_i) < 0$ , then*

$$o^- \left( \sum_{i=1}^n \mathbf{a}_i + \sum_{i=1}^m \mathbf{b}_i \right) = \mathcal{L}^-$$

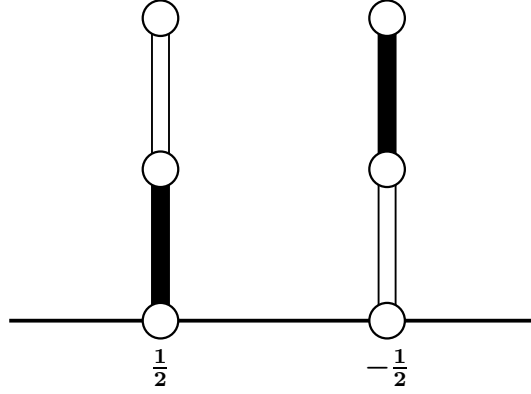
for any dead Left end  $X$ .

**Proof.** The argument from Lemma 4.92 works again, since if Right uses his turn to play in  $X$  then Left responds with a move in  $a_1$  to decrease  $k$  by 1, which is a win for Left by induction.  $\square$

We can now apply Lemma 4.2 to conclude on the invertibility of all numbers.

**Theorem 4.96** *If  $a \in \mathbb{Q}_2$ , then  $\mathbf{a} + \bar{\mathbf{a}} \equiv_{\mathcal{E}} \mathbf{0}$ .*

**Proof.** Without loss of generality we can assume  $a$  is positive. Since every follower of a number is also a number, we can use Lemma 4.2. That is, it suffices to show  $\mathbf{a} + \bar{\mathbf{a}} + X \in \mathcal{L}^- \cup \mathcal{N}^-$  for any Left end  $X \in \mathcal{E}$ . If  $X = 0$ , this is true by Lemma 4.92. If  $X \neq 0$ , then we claim  $\mathbf{a} + \bar{\mathbf{a}} + X \in \mathcal{L}^-$ ; assume this



**Figure 4.19:** Canonical form of  $\frac{1}{2}$  and  $-\frac{1}{2}$  in HACKENBUSH

holds for all followers of  $a$ . Left can win playing first on  $\mathbf{a} + \bar{\mathbf{a}} + X$  by moving to  $\mathbf{a}^L$ , since  $l(\mathbf{a}^L) - r(\bar{\mathbf{a}}) = l(\mathbf{a}^L) - l(\mathbf{a}) < 0$  implies  $\mathbf{a}^L + \bar{\mathbf{a}} + X \in \mathcal{L}^-$  by Lemma 4.95. If Right plays first in  $X$ , then again Left wins by moving  $\mathbf{a}$  to  $\mathbf{a}^L$ ; if Right plays first in  $\mathbf{a}$ , then Left copies in  $\bar{\mathbf{a}}$  and wins on  $\mathbf{a}^L + \bar{\mathbf{a}}^L + X \in \mathcal{L}^-$  by induction.  $\square$

Theorem 4.96 shows that in dead-ending games like COL, DOMINEERING, etc., any position corresponding to a normal-play canonical-form number has an additive inverse under misère play. So, for example, the positions in Figure 4.19 would cancel each other in a game of misère HACKENBUSH.

We now look at sums of dead ends with numbers, and start by giving the misère outcome of such a sum.

**Lemma 4.97** *If  $\{a_i\}_{1 \leq i \leq n}$  is a set of positive numbers and Left ends, and  $\{b_i\}_{1 \leq i \leq m}$  is a set of negative numbers and Right ends, with  $k = \sum_{i=1}^n l(\mathbf{a}_i) - \sum_{i=1}^m r(\mathbf{b}_i)$ , then*

$$o^- \left( \sum_{i=1}^n \mathbf{a}_i + \sum_{i=1}^m \mathbf{b}_i \right) = \begin{cases} \mathcal{L}^- & \text{if } k < 0 \\ \mathcal{N}^- & \text{if } k = 0 \\ \mathcal{R}^- & \text{if } k > 0. \end{cases}$$

**Proof.** The argument from Lemma 4.92 works again, a move from Right may increase  $k$  by at most 1, while a move from Left may decrease  $k$  by at most 1.  $\square$

This gives us the misère monoid of the closure of dead ends and numbers.

**Theorem 4.98** *Under the mapping*

$$G \mapsto \begin{cases} \alpha^{l(G)} & \text{if } G \text{ is a Left end or the canonical form of a positive number} \\ \alpha^{-r(G)} & \text{if } G \text{ is a Right end or the canonical form of a negative number} \end{cases}$$

the misère monoid of the closure of dead ends and canonical-form dyadic rationals is

$$\mathcal{M}_{\mathbb{Z}} = \langle 1, \alpha, \alpha^{-1} \mid \alpha \cdot \alpha^{-1} = 1 \rangle$$

with outcome partition

$$\mathcal{N}^- = \{1\}, \mathcal{L}^- = \{\alpha^{-n} \mid n \in \mathbb{N}^*\}, \mathcal{R}^- = \{\alpha^n \mid n \in \mathbb{N}^*\}.$$

### 4.3.3.2 The partial order of numbers modulo $\mathcal{E}$

Previously, we found that all integers were incomparable in the dead-ending universe. We will see now that non-integer numbers are a bit more cooperative; although not totally ordered, we do have a nice characterisation of the partial order of numbers in the universe  $\mathcal{E}$ . First note that from Corollary 4.57, we get the following result.

**Theorem 4.99** *If  $G \geq_{\mathcal{E}}^- H$ , then  $G \geq^+ H$*

This gives us the following corollary on numbers.

**Corollary 4.100** *If  $a, b \in \mathbb{Q}_2$  and  $a > b$ , then  $\mathbf{a} \not\leq_{\mathcal{E}}^- \mathbf{b}$ .*

Theorem 4.99 says that if  $\mathbf{a} \geq_{\mathcal{E}}^- \mathbf{b}$ , then  $a \geq b$  as real numbers (or as normal-play games). The converse is clearly not true for integers, by Theorem 4.87; it is also not true for non-integers, since  $\frac{1}{2} + \frac{1}{2}$  is a misère  $\mathcal{N}$ -position while  $\frac{3}{4} + \frac{1}{2}$  is a misère  $\mathcal{R}$ -position, so that  $\frac{1}{2} \not\leq_{\mathcal{E}}^- \frac{3}{4}$ . Theorem 4.103 shows that the additional stipulation  $l(\mathbf{a}) \leq l(\mathbf{b})$  is sufficient for  $\mathbf{a} \geq_{\mathcal{E}}^- \mathbf{b}$ . To prove this result we need the following lemmas. As before, non-bold symbols represent actual numbers, so that ' $a < b$ ' indicates inequality of  $a$  and  $b$  as rational numbers, and  $a^L$  means the rational number corresponding to the left-option of the game  $\mathbf{a}$  in canonical form. Recall that if  $\mathbf{x} = \{\mathbf{x}^L \mid \mathbf{x}^R\}$  is in (normal-play) canonical form then  $\mathbf{x}$  is the simplest number (i.e., the number with smallest birthday) such that  $x^L < x < x^R$ . Thus, if  $x^L < x, y < x^R$  and  $x \neq y$ , then  $x$  is simpler than  $y$ .

**Lemma 4.101** *If  $a$  and  $b$  are positive numbers such that  $a^L < b < a$ , then  $l(\mathbf{a}^L) < l(\mathbf{b})$ .*

**Proof.** We have  $a^L < b < a < a^R$ , so  $\mathbf{a}$  must be simpler than  $\mathbf{b}$ . Thus  $b^L \geq a^L$ , since otherwise  $b^L < a^L < b < b^R$  would imply that  $\mathbf{b}$  is simpler than  $\mathbf{a}^L$ , which is simpler than  $\mathbf{a}$ . Now, if  $b^L = a^L$  then  $l(\mathbf{a}^L) = l(\mathbf{b}^L) = l(\mathbf{b}) - 1 < l(\mathbf{b})$ , and if  $b^L > a^L$  then by induction  $a^L < b^L < b < a$  gives  $l(\mathbf{a}^L) < l(\mathbf{b}^L) = l(\mathbf{b}) - 1 < l(\mathbf{b})$ .  $\square$

Lemma 4.101 is now used to prove Lemma 4.102 below, which is needed for the proof of Theorem 4.103. Note that in the following two arguments we frequently use the fact that, if  $\mathbf{a} \geq_{\mathcal{E}}^- \mathbf{b}$ , then Left wins the position  $\mathbf{a} + \bar{\mathbf{b}} + X$  whenever she wins  $X \in \mathcal{E}$ .

**Lemma 4.102** *If  $a$  and  $b$  are positive numbers such that  $a^L < b < a$ , then  $\mathbf{a} >_{\mathcal{E}}^- \mathbf{b}$ .*

**Proof.** Note that  $b \notin \mathbb{Z}$  since there is no integer between  $a^L$  and  $a$  if  $\mathbf{a}$  is in canonical form. We must show that Left wins  $\mathbf{a} + \bar{\mathbf{b}} + X$  whenever she wins  $X \in \mathcal{E}$ .

Case 1:  $b^R = a$ .

Left can win  $\mathbf{a} + \bar{\mathbf{b}} + X$  by playing her winning strategy on  $X$ . If Right moves in  $\mathbf{a} + \bar{\mathbf{b}}$  to  $\mathbf{a}^R + \bar{\mathbf{b}} + X'$ , then Left responds to  $\mathbf{a}^R + \bar{\mathbf{b}}^R + X' = \mathbf{a}^R + \bar{\mathbf{a}} + X'$ , which she wins by induction since  $a^{RL} \leq a^L$  (see Proposition 4.90) gives  $a^{RL} < a < a^R$ . If Right moves to  $\mathbf{a} + \bar{\mathbf{b}}^R + X' = \mathbf{b}^R + \bar{\mathbf{b}}^R + X'$ , with  $X' \in \mathcal{L}^- \cup \mathcal{P}^-$  (since Left is playing her winning strategy in  $X$ ), then Left's response depends on whether  $b^{RL} = b^L$  or  $b^{LR} = b^R$ : in the former case, Left moves to  $\mathbf{b}^{RL} + \bar{\mathbf{b}}^R + X' = \mathbf{b}^L + \bar{\mathbf{b}}^L + X' \equiv_{\mathcal{E}}^- X$ ; in the latter case, Left moves to  $\mathbf{b}^R + \bar{\mathbf{b}}^{LR} + X' = \mathbf{b}^R + \bar{\mathbf{b}}^R + X' \equiv_{\mathcal{E}}^- X'$ . In either case, Left wins as the previous player on  $X' \in \mathcal{L}^- \cup \mathcal{P}^-$ .

When Left runs out of moves in  $X$ , she moves to  $\mathbf{a}^L + \bar{\mathbf{b}} + X''$ . By Lemma 4.101 we know  $l(\mathbf{a}^L) < l(\mathbf{b})$ , and this gives  $o^-(\mathbf{a}^L + \bar{\mathbf{b}} + X'') = \mathcal{L}^-$  by Lemma 4.95.

Case 2:  $b^R \neq a$ .

Note that  $b^R$  cannot be greater than  $a$ , since  $a^L < b < a < a^R$  implies  $\mathbf{a}$  is simpler than  $\mathbf{b}$ , while  $b^L < b < a < b^R$  would imply that  $\mathbf{b}$  is simpler than  $\mathbf{a}$ . So  $b^R < a$ , and together with  $a^L < b < b^R$  this gives  $a^L < b^R < a$ , which shows  $\mathbf{a} \geq_{\mathcal{E}}^- \mathbf{b}^R$  by induction. Similarly  $b^{RL} \leq b^L < b < b^R$  implies  $\mathbf{b}^R \geq_{\mathcal{E}}^- \mathbf{b}$ , by Case 1. Then by transitivity we have  $\mathbf{a} \geq_{\mathcal{E}}^- \mathbf{b}$ .  $\square$

With lemma 4.102, we can now prove Theorem 4.103 below. The symmetric result for negative numbers holds as well.

**Theorem 4.103** *If  $a$  and  $b$  are positive numbers such that  $a > b$  and  $l(\mathbf{a}) \leq l(\mathbf{b})$ , then  $\mathbf{a} >_{\mathcal{E}}^- \mathbf{b}$ .*

**Proof.** By Corollary 4.100, we have  $\mathbf{a} \not\equiv_{\mathcal{E}}^- \mathbf{b}$ , and so it suffices to show  $\mathbf{a} \geq_{\mathcal{E}}^- \mathbf{b}$ . Again we have  $b \notin \mathbb{Z}$ . Since  $a > b$ , if  $b > a^L$ , then Lemma 4.102 gives  $\mathbf{a} \geq_{\mathcal{E}}^- \mathbf{b}$  as required. So assume  $b \leq a^L$ . Again, let  $X \in \mathcal{E}$  be a game which Left wins playing first; we must show Left wins  $\mathbf{a} + \bar{\mathbf{b}} + X$  playing first. Left should follow her winning strategy from  $X$ . If Right plays to  $\mathbf{a} + \bar{\mathbf{b}}^L + X'$ , where  $X' \in \mathcal{L}^- \cup \mathcal{P}^-$ , then Left responds with  $\mathbf{a}^L + \bar{\mathbf{b}}^L + X'$ , which she wins by induction:  $b^L < b \leq a^L$  and  $l(\mathbf{b}^L) = l(\mathbf{b}) - 1 \geq l(\mathbf{a}) - 1 = l(\mathbf{a}^L)$  implies  $\mathbf{a}^L >_{\mathcal{E}}^- \mathbf{b}^L$ .

If Right plays to  $\mathbf{a}^R + \bar{\mathbf{b}} + X'$  (assuming this move exists), then Left's response is  $\mathbf{a}^{RL} + \bar{\mathbf{b}} + X'$  if  $a^{RL} > b$ , or  $\mathbf{a}^R + \bar{\mathbf{b}}^R + X'$  if  $a^{RL} \leq b$ . In the first case, Left wins by induction because  $a^{RL} > b$  and  $l(\mathbf{a}^{RL}) = l(\mathbf{a}^R) - 1 \leq l(\mathbf{a}) - 1 < l(\mathbf{b})$  implies  $\mathbf{a}^{RL} >_{\mathcal{E}}^- \mathbf{b}$ . In the latter case,

note first that in fact  $a^{RL} \neq b$ , since we have already seen that as games they have different left-lengths. Then we see  $a^{RL} < b < a < a^R < a^{RR}$ , which shows  $\mathbf{a}^R$  must be simpler than  $\mathbf{b}$ . This gives  $b^R \leq a^R$ , as otherwise  $b^L < b < a < a^R < b^R$  would imply that  $\mathbf{b}$  is simpler than  $\mathbf{a}^R$ . If  $b^R = a^R$ , then  $\mathbf{b}^R = \mathbf{a}^R$ , and if  $b^R < a^R$ , then we can apply Lemma 4.102 to conclude that  $\mathbf{a}^R >_{\mathcal{E}} \mathbf{b}^R$ . In either case, Left wins  $\mathbf{a}^R + \overline{\mathbf{b}^R} + X'$  with  $X' \in \mathcal{L}^- \cup \mathcal{P}^-$  as the second player.

Finally, if Left runs out of moves in  $X$ , then she moves to  $\mathbf{a}^L + \overline{\mathbf{b}} + X''$  where  $X''$  is a dead Left end; then Left wins by Lemma 4.95 because  $l(\mathbf{a}^L) < l(\mathbf{a}) \leq l(\mathbf{b}) = r(\overline{\mathbf{b}})$ .  $\square$

**Corollary 4.104** *For positive numbers  $a, b \in \mathbb{Q}_2$ ,  $\mathbf{a} >_{\mathcal{E}} \mathbf{b}$  if and only if  $a > b$  and  $l(\mathbf{a}) \leq l(\mathbf{b})$ .*

**Proof.** We need only prove the converse of Theorem 4.103. Suppose  $a > b$  and  $l(\mathbf{a}) > l(\mathbf{b})$ ; then by Theorem 4.99, it cannot be that  $\mathbf{a} \leq_{\mathcal{E}} \mathbf{b}$ , so we need only show  $\mathbf{a} \not\leq_{\mathcal{E}} \mathbf{b}$ . We have  $o^-(\mathbf{b} + \overline{\mathbf{b}}) = \mathcal{N}$ , while  $o^-(\mathbf{a} + \overline{\mathbf{b}}) = \mathcal{R}$ , since in isolation the latter sum is equivalent to the positive integer  $l(\mathbf{a}) - l(\mathbf{b})$ , by Theorem 4.94. Thus  $\mathbf{a} \not\leq_{\mathcal{E}} \mathbf{b}$ .  $\square$

To completely describe the partial order of numbers within  $\mathcal{E}$ , it remains to consider the comparability of  $\mathbf{a}$  and  $\mathbf{b}$  when  $a \geq 0$  and  $b < 0$  (or, symmetrically, when  $a < 0$  and  $b \geq 0$ ). As before, by Corollary 4.100, we cannot have  $\mathbf{a} \leq_{\mathcal{E}} \mathbf{b}$ , and the same argument as above ( $\mathbf{b} + \overline{\mathbf{b}} \in \mathcal{N}^-$  and  $\mathbf{a} + \overline{\mathbf{b}} \in \mathcal{R}^-$ ) shows  $\mathbf{a} \not\leq_{\mathcal{E}} \mathbf{b}$ . The results on the order between numbers are summarised below.

**Theorem 4.105** *The partial order of  $\mathbb{Q}_2$ , modulo  $\mathcal{E}$ , is given by*

$$\begin{aligned} \mathbf{a} &\equiv_{\mathcal{E}} \mathbf{b} && \text{if } a = b, \\ \mathbf{a} &>_{\mathcal{E}} \mathbf{b} && \text{if } 0 < a < b \text{ and } l(\mathbf{a}) \leq l(\mathbf{b}) \\ &&& \text{or } b < a < 0 \text{ and } r(\mathbf{b}) \leq r(\mathbf{a}), \\ \mathbf{a} &\parallel_{\mathcal{E}} \mathbf{b} && \text{otherwise.} \end{aligned}$$

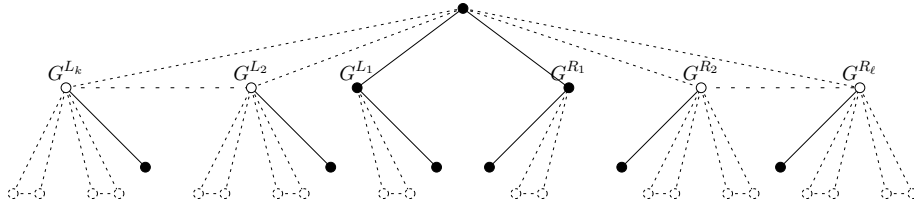
#### 4.3.4 Zeros in the dead-ending universe

We have found that integer and non-integer numbers, as well as all ends, satisfy  $G + \overline{G} \equiv_{\mathcal{E}} \mathbf{0}$ . It is not the case that every game in  $\mathcal{E}$  has its conjugate as inverse; for example,  $* + * \not\equiv_{\mathcal{E}} \mathbf{0}$ , although the equivalence does hold in the universe of dicot games. Milley [26] showed that no dicot game born on day 2 is its conjugate inverse modulo the dead-ending universe, despite six out of the seven of them being their conjugate inverses in the dicot universe.

The following lemma describes an infinite family of games that are not invertible in the universe of dead-ending games.

**Lemma 4.106** *If  $G = \{\mathbf{n}_1, \dots, \mathbf{n}_k | \overline{\mathbf{m}_1}, \dots, \overline{\mathbf{m}_\ell}\}$ , with each  $n_i, m_i \in \mathbb{N}$ , then  $G + \overline{G} \not\equiv_{\mathcal{E}} \mathbf{0}$ .*





**Figure 4.20:** An infinite family of games equivalent to zero modulo  $\mathcal{E}$

**Proof.** Let  $X = \{\mathbf{n}_1, \dots, \mathbf{n}_k, \mathbf{m}_1, \dots, \mathbf{m}_\ell\} \in \mathcal{R}^-$ . We describe a winning strategy for Left playing second in the game  $G + \overline{G} + X$ . Right has no first move in  $X$ , so Right's move is of the form  $G + \overline{\mathbf{n}_i} + X$  or  $\overline{\mathbf{m}_i} + \overline{G} + X$ . Left can respond by moving  $X$  to  $n_i$  or  $m_i$ , respectively, leaving a game equivalent to  $G$  or  $\overline{G}$  modulo  $\mathcal{E}$ . Now Right plays there to a non-positive integer, which as a Right end must be in  $\mathcal{L}^-$  or  $\mathcal{N}^-$ .  $\square$

We conclude with an infinite family of games that are equivalent to zero in the dead-ending universe, which are not of the form  $G + \overline{G}$  for some  $G$ , apart from  $\{\overline{\mathbf{1}}|\mathbf{1}\} = \mathbf{1} + \overline{\mathbf{1}}$ .

**Theorem 4.107** *If  $G$  is a dead-ending game such that every  $G^L$  has a Right option to 0 and at least one  $G^L$ , say  $G^{L_1}$ , is a Left end, and every  $G^R$  has a Left option to 0 and at least one  $G^R$ , say  $G^{R_1}$ , is a Right end, then  $G \equiv_{\mathcal{E}} 0$ .*

**Proof.** Let  $X$  be any game in  $\mathcal{E}$  and suppose Left wins  $X$ . Then Left wins  $G + X$  by following her strategy in  $X$ . If Right plays in  $G$  then he moves to some  $G^R + X'$  from a position  $G + X'$  with  $X' \in \mathcal{L}^- \cup \mathcal{P}^-$ ; Left can respond to  $0 + X'$  and win as the second player. If both players ignore  $G$  then eventually Left runs out of moves in  $X$  and plays to  $G^{L_1} + X''$ , where  $X''$  is a Left end. But  $G^{L_1}$  is a non-zero Left end, so the sum is a Left-win by Lemma 4.80.  $\square$

**Example 4.108** Figure 4.20 illustrates the games considered in Theorem 4.107. Dashed lines indicate that options are present a natural number of times, including 0, and dashed vertices indicate there might be a tree of any size from this vertex, as long as the whole game stays dead-ending.

---

## 4.4 Perspectives

---

In this chapter, we looked at particular games, and took a step into the theory of misère quotients introduced by Plambeck and Siegel, with the universe of dicot games and the dead-ending universe.

In the games we studied, results are mixed.

The misère version of GEOGRAPHY is PSPACE complete even for some ‘small’ class of graphs, but even if the problem EDGE GEOGRAPHY on undirected graph is PSPACE complete in its normal version on general graphs, there exists an algorithm that solves it in the restricted case of bipartite undirected graphs [18].

**Question 4.109** *What is the complexity of finding the misère outcome of any VERTEX GEOGRAPHY position on bipartite undirected graphs?*

In normal version, our results on VERTEXNIM extended to Stockman’s version of VERTEX NIMG, where a vertex of weight 0 is not removed. This does not seem true in its misère version.

As all our results under the misère convention are directly deduced from our results under the normal convention, we make the following conjecture.

**Conjecture 4.110** *The complexity of finding the misère outcome of any VERTEXNIM position on directed graphs with a token on a vertex is the same as the complexity of finding the normal outcome of any VERTEXNIM position on directed graphs with a token on a vertex.*

On TIMBER, we only reduced the problem to oriented forests and found the outcome of any oriented path. As TIMBER is not a game that separates in several components, being able to find the outcome of any connected component would already be interesting.

**Question 4.111** *Is there a polynomial-time algorithm that gives the misère outcome of any TIMBER position on connected directed graphs?*

On TIMBUSH, we only reduced the problem to oriented forests, but the problem is an extension of TIMBER, on which we do not know much.

On TOPPLING DOMINOES, we gave the misère outcome of a single row, and found the misère monoid of TOPPLING DOMINOES positions without grey dominoes. Unexpectedly, the problem seems easier than its normal version. Hence, we ask the following question.

**Question 4.112** *Can one find a polynomial-time algorithm that gives the misère outcome of any TOPPLING DOMINOES position (on several rows)?*

On COL, we gave the misère outcome of any grey subdivided star.

In the case of dicot games, we defined a reduced form and proved it was unique, before using this result to count the number of dicot games in canonical form born by day 3.

One problem of this canonical form is that one needs first to detect  $\mathcal{D}$ -dominated and  $\mathcal{D}$ -reversible options to be able to delete or bypass them, which we do not know whether it is solvable in polynomial time. Hence, we have the following question.

**Question 4.113** *What is the complexity of computing the canonical form of any dicot?*

It would also be interesting to find a canonical form for other universes. Some of the proofs presented in that section were true for any universe, most others would need the universe to be closed by adjoint, but the hard case to adapt seems to be the case of reversible options through any end. The universe of dead-ending games is closed by adjoint, and though we found some way to deal with reversible options through dead ends, it was not enough to give a unique form for each equivalent class modulo the dead-ending universe.

**Question 4.114** *Is there a natural way to define a canonical form for dead-ending games?*

We know we can still bypass most reversible options thanks to the following lemma.

**Lemma 4.115** *Let  $\mathcal{U}$  be a universe and  $G$  be a game. Suppose  $G^{L_1}$  is  $\mathcal{U}$ -reversible through  $G^{L_1 R_1}$ , such that  $G^{L_1 R_1}$  is not a Left end. Let  $G'$  be the game obtained by bypassing  $G^{L_1}$ :*

$$G' = \{(G^{L_1 R_1})^L, G^L \setminus \{G^{L_1}\} | G^R\}.$$

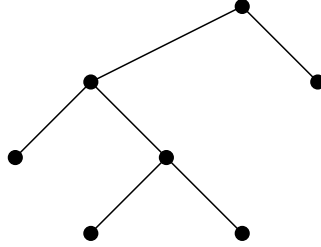
*Then  $G \equiv_{\bar{\mathcal{U}}} G'$ .*

The problem is to deal with options reversible through ends.

In the case of dead-ending games, we found the misère monoid of ends and numbers, and gave the partial order of numbers modulo the dead-ending universe.

The original motivation of studying dead-ending games is to give a natural universe for the specific games we mentioned (COL, DOMINEERING, HACKENBUSH...), games where the players place pieces on a board never to remove them, that we call *placement games*. A formal definition of a placement game is the following.

**Definition 4.116** *Define a game with a set  $\mathcal{M} = \mathcal{M}^L \cup \mathcal{M}^R$  of Left and Right moves and a forbidding function  $\phi : 2^{\mathcal{M}} \rightarrow 2^{\mathcal{M}}$  such that we have for any subset  $X$  of  $2^{\mathcal{M}}$ ,  $\bigcup_{Y \subset X} \phi(Y) \subseteq \phi(X)$  and  $X \subseteq \phi(X)$  as follows: a position is a subset of  $\mathcal{M}$ ; from a position  $M$ , Left can move to  $M \cup \{m\}$  for any  $m \in \mathcal{M}^L \setminus \phi(M)$ , and Right can move to  $M \cup \{m\}$  for any  $m \in \mathcal{M}^R \setminus \phi(M)$ . Then a game  $G$  is a placement game if there exist a set  $\mathcal{M}$ , a function  $\phi$  and a subset  $M$  of  $\mathcal{M}$  such that  $G$  is the position obtained from  $\mathcal{M}$  and  $\phi$  on the subset  $M$  as defined above, modulo the multiplicity of options.*



**Figure 4.21:** A dead-ending game which is not a placement game

Being a placement game is stronger than being a dead-ending game. For example, the position on Figure 4.21 is a dead-ending game, and even a dicot game, which is not a placement game. We can actually prove that if you define recursively the function  $\text{rb}$  such that  $\text{rb}(G) = 0$  if  $G$  is a Right end and  $\text{rb}(G) = 1 + \max_{G^R \in G^R} \text{rb}(G^R)$ , a placement game satisfies the condition  $\text{rb}(G^L) \leq \text{rb}(G)$  for any Left option  $G^L$  of  $G$  (which is not the case for the position on Figure 4.21).

Among properties we naturally consider, the universe of placement games is closed under followers, disjunctive sum and conjugates.

**Question 4.117** *What more can be said about placement games?*

We can also look on a more general context of misère games.

In all examples of games we have seen having an inverse, the conjugate of the game is an inverse. A natural question is: is this always true? Milley [26] proved it is not, giving an example in a universe which is not closed under conjugates. In [34], Plambeck and Siegel gives an example of an impartial universe, disproving even the case where the universe is closed under followers, disjunctive sum and conjugates. This example was not highlighted in the paper as it is prior to the question. Having some answer for the above question, we now ask the following question.

**Question 4.118** *For which universes  $\mathcal{U}$  do we have  $G + H \equiv_{\mathcal{U}}^- 0$  implies  $H \equiv_{\mathcal{U}}^- \bar{G}$ ?*

We know it is true for the universe  $\mathcal{G}$  of all games, as the only way to have  $G + \bar{G} \equiv_{\mathcal{U}}^- 0$  is to have  $G = 0$ , and we have examples of universes where it is not, but even without asking for a characterisation, it would be nice to know if universes such as impartial games, dicot games, dead-ending games, or even placement games have this property.

Another fact one may notice in this chapter is that in all universes we presented where there is no  $\mathcal{P}$ -position, such as the universe of *LR-TOPPLING DOMINOES* and the closure of dead-ends and numbers, all elements are invertible, sometimes even in a bigger universe. This was conjectured by Milley.

**Conjecture 4.119 (Milley (personal communication))** *In any universe  $\mathcal{U}$  closed under followers, disjunctive sum and conjugates, if  $\mathcal{U}$  contains no  $\mathcal{P}$ -position, then every element of  $\mathcal{U}$  has an inverse modulo  $\mathcal{U}$  in  $\mathcal{U}$ .*

For example, the outcome of a position in the closure of *LR-TOPPLING DOMINOES*, dead-ends and canonical-form dyadic rationals is given by the following proposition.

**Proposition 4.120** *If  $G$  is an *LR-TOPPLING DOMINOES* position,  $\{a_i\}_{1 \leq i \leq n}$  is a set of positive numbers and Left ends, and  $\{b_i\}_{1 \leq i \leq m}$  is a set of negative numbers and Right ends, with  $k = l_{td}(G) - r_{td}(G) + \sum_{i=1}^n l(\mathbf{a}_i) - \sum_{i=1}^m r(\mathbf{b}_i)$ , then*

$$o^- \left( G + \sum_{i=1}^n \mathbf{a}_i + \sum_{i=1}^m \mathbf{b}_i \right) = \begin{cases} \mathcal{L}^- & \text{if } k < 0 \\ \mathcal{N}^- & \text{if } k = 0 \\ \mathcal{R}^- & \text{if } k > 0. \end{cases}$$

This gives a misère monoid isomorphic to both the misère monoid of *LR-TOPPLING DOMINOES* positions, and to the monoid of the closure of dead ends and canonical-form dyadic rationals, which raises the following conjecture.

**Conjecture 4.121** *If  $\mathcal{U}$  and  $\mathcal{U}'$  are two universes closed under followers, disjunctive sum and conjugates having misère monoids isomorphic to  $\mathcal{M}_{\mathbb{Z}}$ , then the misère monoid of the closure of positions of  $\mathcal{U}$  and  $\mathcal{U}'$  is also isomorphic to  $\mathcal{M}_{\mathbb{Z}}$ .*

This might even be strengthened as follows.

**Conjecture 4.122** *If  $\mathcal{U}$  and  $\mathcal{U}'$  are two universes closed under followers, disjunctive sum and conjugates having isomorphic misère monoids, then the misère monoid of the closure of positions of  $\mathcal{U}$  and  $\mathcal{U}'$  is also isomorphic to their common misère monoid.*

In the last two conjectures, we consider the outcome partition as part of the misère monoid, that is we consider they should be isomorphic as well.



## Chapter 5

# Domination Game

The domination game is not a combinatorial game. Nevertheless, some tools used in its study are quite similar to some combinatorial tools. For example, the imagination strategy method proposed in [7] is similar to the stealing strategy argument stating the player having a winning strategy in HEX. We here show another parallel by considering the game on a non-connected graph as a disjunctive sum.

Recall that a vertex is said to dominate itself and its neighbours, and that a set of vertices is a dominating set if every vertex of the graph is dominated by some vertex in the set.

The Domination game was introduced by Brešar, Klavžar and Rall in [7]. It is played on a finite graph  $G$  by two players, Dominator and Staller. They alternate turns in choosing a vertex that dominates at least one new vertex. The game ends when there is no possible move anymore, that is when the chosen vertices form a dominating set. Dominator's goal is that the game finishes in as few moves as possible while Staller tries to keep the game going as long as she can. There are two possible variants of the game, depending on who starts the game. In Game 1, Dominator starts, while in Game 2, Staller starts. The game domination number, denoted by  $\gamma_g(G)$ , is the total number of chosen vertices in Game 1 when both players play optimally. Similarly, the Staller-start game domination number  $\gamma'_g(G)$  is the total number of chosen vertices in Game 2 when both players play optimally.

Variants of the game where one player is allowed to pass a move once were already considered in [20] (and possibly elsewhere). In the Dominator-pass game, Dominator is allowed to pass one move, while in the Staller-pass game, Staller is. We denote respectively by  $\gamma_g^{dp}$  and  $\gamma'_g^{dp}$  the size of the set of chosen vertices in game 1 and 2 where Dominator is allowed to pass one move, and by  $\gamma_g^{sp}$  and  $\gamma'_g^{sp}$  the size of the set of chosen vertices in game 1 and 2 where Staller is allowed to pass a move. Note that passing does not count as a move in the game domination number, as the value is the number of chosen vertices.

We say that a graph  $G$  realises a pair  $(k, \ell) \in \mathbb{N} \times \mathbb{N}$  if  $\gamma_g(G) = k$  and  $\gamma'_g(G) = \ell$ . For a graph  $G = (V, E)$  and a subset of vertices  $S \subseteq V$ , we denote by  $G|S$  the partially dominated graph  $G$  where the vertices of  $S$  are dominated. Kinnersley, West and Zamani [20] proved what is known as the continuation principle:

**Theorem 5.1 (Kinnersley et al[20]) [Continuation Principle]** *Let  $G$  be a graph and  $A, B \subseteq V(G)$ . If  $B \subseteq A$ , then  $\gamma_g(G|B) \geq \gamma_g(G|A)$  and  $\gamma'_g(G|B) \leq \gamma'_g(G|A)$ .*

This very useful principle to prove inequalities involving  $\gamma_g$  and  $\gamma'_g$  has the following corollary, part of which was already proved in [7].

**Theorem 5.2 (Brešar et al. [7], Kinnersley et al. [20])** *For any graph  $G$ ,  $|\gamma_g(G) - \gamma'_g(G)| \leq 1$*

As a consequence of this theorem, we have that realisable pairs are necessarily of the form  $(k, k+1)$ ,  $(k, k)$  and  $(k, k-1)$ . It is known that all these pairs are indeed realisable, examples of graphs of each of these three types are given in [7, 8, 20, 21]. We say a partially dominated graph  $G$  is a  $(k, +)$  (resp.  $(k, =)$ ,  $(k, -)$ ) if  $\gamma_g(G) = k$  and  $\gamma'_g(G) = k+1$  (resp.  $\gamma_g(G) = k$  and  $\gamma'_g(G) = k$ ,  $\gamma_g(G) = k$  and  $\gamma'_g(G) = k-1$ ). Additionally, we say that a graph  $G$  is a PLUS (resp. EQUAL, MINUS) if  $G$  is  $(k, +)$  (resp.  $(k, =)$ ,  $(k, -)$ ) for some  $k \geq 1$ .

**Observation 5.3** *If a partially dominated graph  $G|S$  is a  $(k, -)$ , then for any legal move  $u$  in  $G|S$ , the graph  $G|(S \cup N[u])$  is a  $(k-2, +)$ .*

**Proof.** Let  $G|S$  be a  $(k, -)$  and  $u$  be any legal move in  $G|S$ . By definition of the game domination number, we have  $k = \gamma_g(G|S) \leq 1 + \gamma'_g(G|S \cup N[u])$ . Similarly,  $k-1 = \gamma'_g(G|S) \geq 1 + \gamma_g(G|S \cup N[u])$ . By Theorem 5.2, we get that

$$k-1 \leq \gamma'_g(G|S \cup N[u]) \leq \gamma_g(G|S \cup N[u]) + 1 \leq k-1$$

and so equality holds throughout this inequality chain. Thus  $G|(S \cup N[u])$  is a  $(k-2, +)$ , as required.  $\square$

We say that a graph  $G$  is a *no-minus graph* if for any subset of vertices  $S$ ,  $\gamma_g(G|S) \leq \gamma'_g(G|S)$ . Intuitively, it seems that no player gets any advantage to pass in a no-minus graph.

In this chapter, we are interested in no-minus graphs and possible realisations of unions of graphs. In Section 5.1, we prove that tri-split graphs and dually chordal graphs are no-minus graphs. In Section 5.2, we give bounds on the game domination number of the union of two graphs, given that we know the game domination number of each component of the union, first when both graphs are no-minus graphs, then in the general case.

The results presented in this chapter are a joint work with Paul Dorbec and Gašper Košmrlj [13].



<b>5.2</b>	<b>The domination game played on unions of graphs</b>	<b>172</b>
5.2.1	Union of no-minus graphs . . . . .	172
5.2.2	General case . . . . .	175
<b>5.3</b>	<b>Perspectives . . . . .</b>	<b>179</b>

## 5.1 About no-minus graphs

In this section, we consider no-minus graphs. We first prove the following proposition on no-minus graphs, showing that being allowed to pass is not helpful in such graphs.

**Proposition 5.4** *If  $G$  is a no-minus graph, then  $\gamma_g^{sp}(G) = \gamma_g^{dp}(G) = \gamma_g(G)$  and  $\gamma_g'^{sp}(G) = \gamma_g'^{dp}(G) = \gamma_g'(G)$ .*

**Proof.** First, note that a player would pass a move only if it benefits them, so for any graph  $G$  (even if not a no-minus graph), we have  $\gamma_g^{dp}(G) \leq \gamma_g(G) \leq \gamma_g^{sp}(G)$  and  $\gamma_g'^{dp}(G) \leq \gamma_g'(G) \leq \gamma_g'^{sp}(G)$ . Now, suppose a no-minus graph  $G$  satisfies  $\gamma_g^{dp}(G) < \gamma_g(G)$ . We use the imagination strategy to reach a contradiction.

Consider a normal Dominator-start game played on  $G$  where Dominator imagines he is playing a Dominator-pass game, while Staller plays optimally in the normal game. Since  $\gamma_g^{dp}(G) < \gamma_g(G)$ , the strategy of Dominator includes passing a move at some point, say after  $x$  moves have been played. Let  $S$  be the set of dominated vertices at that point. Since Dominator played optimally the Dominator-pass domination game (but not necessarily Staller), if he was allowed to pass that move the game should end in no more than  $\gamma_g^{dp}(G)$ . We thus have the following inequality:

$$x + \gamma_g'(G|S) \leq \gamma_g^{dp}(G)$$

Now, remark that since Staller played optimally in the normal game, we have that

$$x + \gamma_g(G|S) \geq \gamma_g(G)$$

Adding the fact that  $G$  is a no-minus, so that  $\gamma_g(G|S) \leq \gamma_g'(G|S)$ , we reach the following contradiction:

$$\gamma_g(G) \leq x + \gamma_g(G|S) \leq x + \gamma_g'(G|S) \leq \gamma_g^{dp}(G) < \gamma_g(G).$$

Similar arguments complete the proof for the Staller-pass and/or Staller-start games.  $\square$

The next lemma also expresses an early property of no-minus graphs. It is an extension of a result on forests from [20], the proof is about the same.

**Lemma 5.5** *Let  $G$  be a graph,  $S \subseteq V(G)$ , such that for any  $S' \supseteq S$ ,  $\gamma_g(G|S') \leq \gamma'_g(G|S')$ . Then we have  $\gamma_g(G \cup K_1|S) \geq \gamma_g(G|S) + 1$  and  $\gamma'_g(G \cup K_1|S) \geq \gamma'_g(G|S) + 1$ .*

**Proof.** Given a graph  $G$  and a set  $S$  satisfying the hypothesis, we use induction on the number of vertices in  $V(G) \setminus S$ . If  $V(G) \setminus S = \emptyset$ , the claim is trivial. Suppose now that  $S \subsetneq V(G)$  and that the claim is true for every  $G|S'$  with  $S \subsetneq S'$ .

Consider first game 1. Let  $v$  be an optimal first move for Dominator in the game  $G \cup K_1|S$ . If  $v$  is the added vertex, then  $\gamma_g(G \cup K_1|S) = \gamma'_g(G|S) + 1 \geq \gamma_g(G|S) + 1$  by our assumption on  $G|S$ , and the inequality follows. Otherwise, let  $S' = S \cup N[v]$ . By the choice of the move and induction hypothesis, we have  $\gamma_g(G \cup K_1|S) = 1 + \gamma'_g(G \cup K_1|S') \geq 1 + \gamma'_g(G|S') + 1$ . Since  $v$  is not necessarily an optimal first move for Dominator in the game on  $G|S$ , we also have that  $\gamma_g(G|S) \leq 1 + \gamma'_g(G|S')$  and the result follows.

Consider now game 2. Let  $w$  be an optimal first move for Staller in the game  $G|S$ , and let  $S'' = S \cup N[w]$ . By optimality of this move, we have  $\gamma'_g(G|S) = 1 + \gamma_g(G|S'')$ . Playing also  $w$  in  $G \cup K_1|S$ , Staller gets  $\gamma'_g(G \cup K_1|S) \geq 1 + \gamma_g(G \cup K_1|S'') \geq 2 + \gamma_g(G|S'')$  by induction hypothesis. The required inequality follows.  $\square$

It is known that forests are no-minus graphs [20]. We now propose two other families of graphs that are no-minus. The first is the family of tri-split graphs, a generalisation of split graphs and pseudo-split graph (except it does not contain  $C_5$ ) inspired by [23]. A graph is tri-split if its set of vertices can be partitioned into three disjoint sets  $A \neq \emptyset$ ,  $B$  and  $C$  with the following properties:

$$\begin{aligned} \forall u \in A, \forall v \in A \cup C : uv \in E(G), \\ \forall u \in B, \forall v \in B \cup C : uv \notin E(G). \end{aligned}$$

We prove the following.

**Theorem 5.6** *Connected tri-split graphs are no-minus graphs.*

**Proof.** Let  $G$  be a tri-split graph with the corresponding partition  $(A, B, C)$ , let  $S \subseteq V(G)$  be a subset of dominated vertices, and consider the game played on  $G|S$ . If the game on  $G|S$  ends in at most two moves, then clearly  $\gamma_g(G|S) \leq \gamma'_g(G|S)$ . From now on, we assume that  $\gamma_g(G) \geq 3$ .

Observe that Dominator has an optimal strategy playing only in  $A$  (in both game 1 and game 2). Indeed, any vertex  $u$  in  $B$  dominates only itself and some vertex in  $A$  (at least one by connectivity). Any neighbour  $v$  of  $u$  in  $A$  dominates all of  $A$  and  $v$ , so is a better move than  $u$  for Dominator by the continuation principle. Similarly, the neighbourhood of any vertex in

$C$  is included in the neighbourhood of any vertex in  $A$ . So we now assume Dominator only plays in  $A$  in the rest of the proof.

Suppose we know an optimal strategy on Game 2 for Dominator, we propose an (imagination) strategy for Game 1 guaranteeing it will finish no later than Game 2. Let Dominator imagine a first move  $v_0 \in B \cup C$  from Staller and play the game on  $G|S$  as if playing in  $G|(S \cup N[v_0])$ . Staller plays optimally on  $G|S$  not knowing about Dominator's imagined game. Note that after Dominator's first move, the only difference between the imagined game and the real game is that  $v_0$  is dominated in the first but possibly not in the second. Indeed, all the neighbours of  $v_0$  belong to  $A \cup C$ , which are dominated by Dominator's first move (in  $A$  by our assumption). Therefore, any move played by Dominator in his imagined game is legal in the real game, though Staller may eventually play a move in the real game that is illegal in the imagined game, provided it newly dominates only  $v_0$ . If she does so and the game is not finished yet, then Dominator imagines she played any legal move  $v_1$  in  $B$  instead and continues. This may happen again, leading Dominator to imagine a move  $v_2$  and so on. Denote by  $v_i$  the last such vertex before the game ends, we thus have that  $v_i$  is the only vertex possibly dominated in the imagined game but not in the real game.

Assume now that the imagined game is just finished. Denote by  $k_{\mathcal{I}}$  the total number of moves in this imagined game. Note that the imagined game looks like a Game 2 where Dominator played optimally but possibly not Staller. We thus have that  $k_{\mathcal{I}} \leq \gamma'_g(G|S)$ . At that point, either the real game is finished or only  $v_i$  is not yet dominated. So the real game finishes at latest with the next move of any player, and the number of moves in the real game  $k_{\mathcal{R}}$  satisfies  $k_{\mathcal{R}} \leq k_{\mathcal{I}} - 1 + 1$ . Moreover, in the real game, Staller played optimally but possibly not Dominator, so  $k_{\mathcal{R}} \geq \gamma_g(G|S)$ . We can now conclude the proof bringing together all these inequalities into

$$\gamma_g(G|S) \leq k_{\mathcal{R}} \leq k_{\mathcal{I}} \leq \gamma'_g(G|S).$$

□

The second family of graphs we prove to be no-minus is the family of dually chordal graphs, see [6]. Let  $G$  be a graph,  $v$  one of its vertices. A vertex  $u$  in  $N[v]$  is a maximum neighbour of  $v$  if for all  $w \in N[v]$ , we have  $N[w] \subseteq N[u]$ . A vertex ordering  $v_1, \dots, v_n$  is a *maximum neighbourhood ordering* if for each  $i \leq n$ ,  $v_i$  has a maximum neighbour in  $G[\{v_1, \dots, v_i\}]$ . A graph is dually chordal if it has a maximum neighbourhood ordering. Note that forests and interval graphs are dually chordal [35].

**Theorem 5.7** *Dually chordal graphs are no-minus graphs.*

**Proof.** We prove the result by induction on the number of non-dominated vertices. Let  $G$  be a dually chordal graph with  $v_1, \dots, v_n$  a maximum neighbourhood ordering of  $V(G)$ . Let  $S \subseteq V(G)$  be a subset of dominated vertices

and denote by  $j$  the largest index such that  $v_j$  is not in  $S$ . We suppose by way of contradiction that  $G|S$  is a  $(k, -)$ , note that necessarily  $k \geq 3$ . Let  $v_i$  be a maximum neighbour of  $v_j$  in  $G[\{v_1, \dots, v_j\}]$ . Let  $u$  be an optimal move for Staller in  $G|(S \cup N[v_i])$  and let  $S' = S \cup N[v_i] \cup N[u]$ . By Observation 5.3,  $G|(S \cup N[u])$  and  $G|(S \cup N[v_i])$  are both  $(k-2, +)$ , so  $\gamma_g(G|S \cup N[u]) = k-2$  and  $\gamma'_g(G|S \cup N[v_i]) = k-1$ . By optimality of  $u$ , we get that

$$k-1 = \gamma'_g(G|S \cup N[v_i]) = \gamma_g(G|S') + 1.$$

The vertex  $u$  is not a neighbour of  $v_j$ , or its closed neighbourhood in  $G[\{v_1, \dots, v_j\}]$  would be included in  $N[v_i]$  and  $\{v_{j+1}, \dots, v_n\} \subseteq S$ , so playing  $u$  would not be legal in  $G|(S \cup N[v_i])$ . Therefore, by continuation principle (Theorem 5.1),

$$\gamma_g(G|S \cup N[u]) \geq \gamma_g(G|S' \setminus \{v_j\}).$$

Moreover, because all vertices at distance at most 2 from  $v_j$  are dominated in  $G|S'$ , we get that  $\gamma_g(G|S' \setminus \{v_j\}) = \gamma_g(G \cup K_1|S')$ . Now using induction hypothesis to apply Lemma 5.5, we get

$$\gamma_g(G|S' \setminus \{v_j\}) \geq \gamma_g(G|S') + 1.$$

We thus conclude that

$$k-2 = \gamma_g(G|S \cup N[u]) \geq \gamma_g(G|S' \setminus \{v_j\}) \geq \gamma_g(G|S') + 1 = k-1,$$

which leads to a contradiction. Therefore,  $G|S$  is not a MINUS and this concludes the proof.  $\square$

---

## 5.2 The domination game played on unions of graphs

---

### 5.2.1 Union of no-minus graphs

In this subsection, we are interested in the possible values that the union of two no-minus graphs may realise, according to the realisations of its components. We in particular show that the union of two no-minus graphs is always a no-minus graph.

We first prove a very general result that will allow us to compute almost all the bounds obtained later.

**Theorem 5.8** *Let  $G_1|S$  and  $G_2|S'$  be two partially dominated graphs and  $x$*

be any legal move in  $G_1|S$ . We have

$$\gamma_g(G_1 \cup G_2|S \cup S') \geq \min \left( \gamma_g(G_1|S) + \gamma_g^{dp}(G_2|S'), \gamma_g^{dp}(G_1|S) + \gamma_g(G_2|S') \right) \quad (5.1)$$

$$\gamma_g(G_1 \cup G_2|S \cup S') \leq 1 + \max \left( \gamma'_g(G_1|S \cup N[x]) + \gamma'_g{}^{sp}(G_2|S'), \gamma'_g{}^{sp}(G_1|S \cup N[x]) + \gamma'_g(G_2|S') \right) \quad (5.2)$$

$$\gamma'_g(G_1 \cup G_2|S \cup S') \leq \max \left( \gamma'_g(G_1|S) + \gamma'_g{}^{sp}(G_2|S'), \gamma'_g{}^{sp}(G_1|S) + \gamma'_g(G_2|S') \right) \quad (5.3)$$

$$\gamma'_g(G_1 \cup G_2|S \cup S') \geq 1 + \min \left( \gamma_g(G_1|S \cup N[x]) + \gamma_g^{dp}(G_2|S'), \gamma_g^{dp}(G_1|S \cup N[x]) + \gamma_g(G_2|S') \right) \quad (5.4)$$

**Proof.** To prove all these bounds, we simply describe what a player can do by using a *strategy of following*, i.e. always answering to his opponent moves in the same graph if possible.

Let us first consider Game 1 in  $G_1 \cup G_2|S \cup S'$  and what happens when Staller adopts the strategy of following. Assume first that the game in  $G_1$  finishes before the game in  $G_2$ . Then Staller is sure with her strategy that the number of moves in  $G_1$  is at least  $\gamma_g(G_1|S)$ . However, when  $G_1$  finishes, Staller may be forced to play in  $G_2$  if Dominator played the final move in  $G_1$ . This situation somehow allows Dominator to pass once in  $G_2$ , but no more. So we can ensure that the number of moves in  $G_2$  is no less than  $\gamma_g^{dp}(G_2|S')$ . Thus, in that case, the total number of moves is no less than  $\gamma_g(G_1|S) + \gamma_g^{dp}(G_2|S')$ . If on the other hand the game in  $G_2$  finishes first, we get similarly that the number of moves is then no less than  $\gamma_g^{dp}(G_1|S) + \gamma_g(G_2|S')$ . Since she does not decide which game finishes first, Staller can guarantee that

$$\gamma_g(G_1 \cup G_2|S \cup S') \geq \min (\gamma_g(G_1|S) + \gamma_g^{dp}(G_2|S'), \gamma_g^{dp}(G_1|S) + \gamma_g(G_2|S')).$$

The same arguments in Game 2 with Dominator adopting the strategy of following ensures that

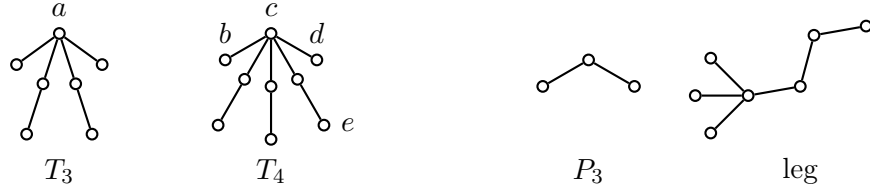
$$\gamma'_g(G_1 \cup G_2|S \cup S') \leq \max (\gamma'_g(G_1|S) + \gamma'_g{}^{sp}(G_2|S'), \gamma'_g{}^{sp}(G_1|S) + \gamma'_g(G_2|S')).$$

Let us come back to Game 1. Suppose Dominator plays some vertex  $x$  in  $V(G_1)$  and then adopts the strategy of following. Then he can ensure that  $\gamma_g(G_1 \cup G_2|S \cup S') \leq 1 + \gamma'_g(G_1 \cup G_2|S \cup S' \cup N_{G_1}[x])$  and thus that

$$\gamma_g(G_1 \cup G_2|S \cup S') \leq 1 + \max \left( \gamma'_g(G_1|S \cup N[x]) + \gamma'_g{}^{sp}(G_2|S'), \gamma'_g{}^{sp}(G_1|S \cup N[x]) + \gamma'_g(G_2|S') \right).$$

The same is true for Staller in Game 2 to obtain Inequality (5.4).  $\square$

In the case of the union of two no-minus graphs, these inequalities allow us to give rather precise bounds on the possible values realised by the union. The first case is when one of the components is an EQUAL.



**Figure 5.1:** The trees  $T_3$  and  $T_4$ , the graph  $P_3$  and the leg

**Theorem 5.9** *Let  $G_1|S$  and  $G_2|S'$  be partially dominated no-minus graphs. If  $G_1|S$  is a  $(k, =)$  and  $G_2|S'$  is a  $(\ell, \star)$  (with  $\star \in \{=, +\}$ ), then the disjoint union  $G_1 \cup G_2|S \cup S'$  is a  $(k + \ell, \star)$ .*

**Proof.** We use inequalities from Theorem 5.8. Note that since  $G_1$  and  $G_2$  are no-minus graphs, we can apply Proposition 5.4 and get that the Staller-pass and Dominator-pass games on any partially dominated  $G_1$  and  $G_2$  is the same as the corresponding game.

For Game 1, let Dominator choose an optimal move  $x$  in  $G_2|S'$ , for which we get  $\gamma'_g(G_2|S' \cup N[x]) = \ell - 1$ . Applying Inequalities (5.1) and (5.2) interchanging the role of  $G_1$  and  $G_2$ , we then get that

$$k + \ell \leq \gamma_g(G_1 \cup G_2|S \cup S') \leq 1 + k + \ell - 1.$$

For Game 2, Staller can also choose an optimal move  $x$  in  $G_2|S'$  for which  $\gamma_g(G_2|S' \cup N[x]) = \gamma'_g(G_2|S') - 1$ , and applying Inequalities (5.3) and (5.4), we get that  $\gamma'_g(G_1 \cup G_2|S \cup S') = \gamma'_g(G_1|S) + \gamma'_g(G_2|S')$ .  $\square$

We are now left with the case where both components are PLUS.

**Theorem 5.10** *Let  $G_1|S$  and  $G_2|S'$  be partially dominated no-minus graphs such that  $G_1|S$  is  $(k, +)$  and  $G_2|S'$  is  $(\ell, +)$ . Then*

$$\begin{aligned} k + \ell &\leq \gamma_g(G_1 \cup G_2|S \cup S') \leq k + \ell + 1, \\ k + \ell + 1 &\leq \gamma'_g(G_1 \cup G_2|S \cup S') \leq k + \ell + 2. \end{aligned}$$

*In addition, all bounds are tight.*

**Proof.** Similarly as in the proof before, taking  $x$  an optimal first move for Dominator in  $G_1|S$  and applying Inequalities (5.1) and (5.2), we get that  $k + \ell \leq \gamma_g(G_1 \cup G_2|S \cup S') \leq k + \ell + 1$ . Also, taking for  $x$  an optimal first move for Staller in  $G_1|S$  and applying Inequalities (5.3) and (5.4), we get that  $k + \ell + 1 \leq \gamma'_g(G_1 \cup G_2|S \cup S') \leq k + \ell + 2$ .

We now propose examples showing that these bounds are tight. Denote by  $T_i$  the tree made of a root vertex  $r$  of degree  $i + 1$  adjacent to two leaves and  $i - 1$  paths of length 2. Figure 5.1 shows the trees  $T_2$  and  $T_3$ . Note

that the domination number of  $T_i$  is  $\gamma(T_i) = i$ . For the domination game,  $T_i$  realises  $(i, i + 1)$ . We claim that for any  $k, \ell$ ,  $\gamma_g(T_k \cup T_\ell) = k + \ell + 1$ . Note that if  $x$  is a leaf adjacent to the degree  $i + 1$  vertex  $r$  in some  $T_i$ , then  $i$  vertices are still needed to dominate  $T_i|N[x]$ . Then a strategy for Staller so that the game does not finish in less than  $k + \ell + 1$  moves is to answer to any move from Dominator in the other tree by such a leaf (e.g. in Figure 5.1, answer to Dominator's move in  $a$  with  $b$ ). Then two moves are played already and still  $k + \ell - 1$  vertices at least are needed to dominate the graph. The upper bound is already known. Similarly, if  $k \geq 2$ , for any  $\ell$ ,  $\gamma'_g(T_k \cup T_\ell) = k + \ell + 2$ . Staller's strategy would be to start on a leaf adjacent to the root of  $T_k$  (e.g.  $b$  in Figure 5.1). Then whatever Dominator's answer (optimally  $a$ ), Staller can play a second leaf adjacent to a root ( $d$ ). Then either Dominator answers to the second root ( $c$ ) and at least  $k + \ell - 2$  moves are required to dominate the other vertices, or he tries to dominate a leaf already (say  $e$ ) and Staller can still play the root ( $c$ ), leaving  $k + \ell - 3$  necessary moves after the five initial moves.

To prove that the lower bounds are tight, it is enough to consider the path on three vertices  $P_3$  and the leg drawn in Figure 5.1, that is the tree consisting in a claw whose degree three vertex is attached to a  $P_3$ . The path  $P_3$  realises  $(1, 2)$ , the leg realises  $(3, 4)$ , checking that the union is indeed a  $(4, 5)$  is left to the reader.  $\square$

The next corollary directly follows from the above theorems.

**Corollary 5.11** *No-minus graphs are closed under disjoint union.*

Note that thanks to that corollary, we can extend the result of Theorem 5.6 to all tri-split graphs.

**Corollary 5.12** *All tri-split graphs are no-minus graphs.*

## 5.2.2 General case

In this subsection, we consider a union of any two graphs.

Depending on the parity of the length of the game, we can refine Theorem 5.8 as follows:

**Theorem 5.13** *Let  $G_1|S_1$  and  $G_2|S_2$  be partially dominated graphs.*

- *If  $\gamma_g(G_1|S_1)$  and  $\gamma_g(G_2|S_2)$  are both even, then*

$$\gamma_g(G_1 \cup G_2|S_1 \cup S_2) \geq \gamma_g(G_1|S_1) + \gamma_g(G_2|S_2) \quad (5.5)$$

- *If  $\gamma_g(G_1|S_1)$  is odd and  $\gamma'_g(G_2|S_2)$  is even, then*

$$\gamma_g(G_1 \cup G_2|S_1 \cup S_2) \leq \gamma_g(G_1|S_1) + \gamma'_g(G_2|S_2) \quad (5.6)$$

- If  $\gamma'_g(G_1|S_1)$  and  $\gamma'_g(G_2|S_2)$  are both even, then

$$\gamma'_g(G_1 \cup G_2|S_1 \cup S_2) \leq \gamma'_g(G_1|S_1) + \gamma'_g(G_2|S_2) \quad (5.7)$$

- If  $\gamma'_g(G_1|S_1)$  is odd and  $\gamma_g(G_2|S_2)$  is even, then

$$\gamma'_g(G_1 \cup G_2|S_1 \cup S_2) \geq \gamma'_g(G_1|S_1) + \gamma_g(G_2|S_2) \quad (5.8)$$

**Proof.** The proof is similar to the proof of Theorem 5.8. For inequality (5.5), let Staller use the strategy of following, assume without loss of generality that  $G_1$  is dominated before  $G_2$ . If Dominator played optimally in  $G_1$ , by parity Staller played the last move there and Dominator could not pass a move in  $G_2$ , thus he could not manage less moves in  $G_2$  than  $\gamma_g(G_2|S_2)$ . Yet Dominator may have played so that one more move was necessary in  $G_1$  in order to be able to pass in  $G_2$ . Then the number of moves played in  $G_2$  may be only  $\gamma_g^{dp}(G_2|S_2)$ , but this is no less than  $\gamma_g(G_2|S_2) - 1$  and overall, the number of moves is the same. Hence we have  $\gamma_g(G_1 \cup G_2|S_1 \cup S_2) \geq \gamma_g(G_1|S_1) + \gamma_g(G_2|S_2)$ . The same argument with Dominator using the strategy of following gives inequality (5.7).

Similarly, for inequality (5.6), Let Dominator start with playing an optimal move  $x$  in  $G_1|S_1$  and then apply the strategy of following. Then Staller plays in  $G_1 \cup G_2|(S_1 \cup N[x]) \cup S_2$ , where  $\gamma'_g(G_1|S_1 \cup N[x]) = \gamma_g(G_1|S_1) - 1$  is even, as well as  $\gamma'_g(G_2|S_2)$ . Then by the previous argument,  $\gamma_g(G_1 \cup G_2|S_1 \cup S_2) \leq \gamma_g(G_1|S_1) + \gamma'_g(G_2|S_2)$ . Inequality (5.8) is obtained with a similar strategy for Staller.  $\square$

Using Theorem 5.8 and 5.13, we argue the 21 different cases, according to the type and the parity of each of the components of the union. To simplify the computation, we simply propose the following corollary of Theorem 5.8

**Corollary 5.14** *Let  $G_1|S_1$  and  $G_2|S_2$  be two partially dominated graphs. We have*

$$\gamma_g(G_1 \cup G_2|S_1 \cup S_2) \geq \gamma_g(G_1|S_1) + \gamma_g(G_2|S_2) - 1, \quad (5.9)$$

$$\gamma_g(G_1 \cup G_2|S_1 \cup S_2) \leq \gamma_g(G_1|S_1) + \gamma'_g(G_2|S_2) + 1, \quad (5.10)$$

$$\gamma'_g(G_1 \cup G_2|S_1 \cup S_2) \leq \gamma'_g(G_1|S_1) + \gamma'_g(G_2|S_2) + 1, \quad (5.11)$$

$$\gamma'_g(G_1 \cup G_2|S_1 \cup S_2) \geq \gamma'_g(G_1|S_1) + \gamma_g(G_2|S_2) - 1. \quad (5.12)$$

**Proof.** To prove these inequalities, with simply apply inequalities of Theorem 5.8 in a general case. We choose for the vertex  $x$  an optimal move, getting for example that  $\gamma'_g(G_1|S_1 \cup N[x]) = \gamma_g(G_1|S_1) - 1$ . We also use Lemma ?? and get for example  $\gamma_g^{dp}(G_2|S_2) \geq \gamma_g(G_2|S_2) - 1$ .  $\square$

We now present the general bounds in Table 5.2, which should be read as follows. The first two columns give the types and parities of the components



of the union, where  $e$ ,  $e_1$  and  $e_2$  denote even numbers and  $o$ ,  $o_1$ , and  $o_2$  denote odd numbers. The next two columns give the bounds on the domination game numbers of the union. In the last two columns, we give the inequalities we use to get these bounds. We add a  $*$  to the inequality number when the inequality is used exchanging  $G_1$  and  $G_2$ .

$G_1$	$G_2$	$\gamma_g$	$\gamma'_g$	for $\gamma_g$	for $\gamma'_g$
$(o_1, -)$	$(o_2, +)$	$\gamma_g = o_1 + o_2 - 1$	$\gamma'_g = o_1 + o_2$	(5.9),(5.6*)	(5.12*), (5.7)
$(e_1, -)$	$(e_2, +)$	$\gamma_g = e_1 + e_2$	$\gamma'_g = e_1 + e_2 + 1$	(5.5),(5.10*)	(5.8*), (5.11)
$(o_1, -)$	$(o_2, -)$	$\gamma_g = o_1 + o_2 - 1$	$\gamma'_g = o_1 + o_2 - 2$	(5.9),(5.6)	(5.12),(5.7)
$(e_1, -)$	$(e_2, -)$	$\gamma_g = e_1 + e_2$	$\gamma'_g = e_1 + e_2 - 1$	(5.5),(5.10)	(5.8),(5.11)
$(o_1, =)$	$(o_2, -)$	$\gamma_g = o_1 + o_2 - 1$	$o_1 + o_2 - 1 \leq \gamma'_g \leq o_1 + o_2$	(5.9),(5.6)	(5.12*), (5.11)
$(e_1, =)$	$(e_2, -)$	$\gamma_g = e_1 + e_2$	$e_1 + e_2 - 1 \leq \gamma'_g \leq e_1 + e_2$	(5.5),(5.10)	(5.12),(5.11)
$(e, =)$	$(o, -)$	$e + o - 1 \leq \gamma_g \leq e + o$	$\gamma'_g = e + o - 1$	(5.9),(5.10)	(5.12),(5.7)
$(o, =)$	$(e, -)$	$e + o - 1 \leq \gamma_g \leq e + o$	$\gamma'_g = e + o$	(5.9),(5.10)	(5.8),(5.11)
$(e, =)$	$(o, +)$	$e + o - 1 \leq \gamma_g \leq e + o$	$e + o \leq \gamma'_g \leq e + o + 1$	(5.9),(5.6*)	(5.12*), (5.11)
$(o, -)$	$(e, +)$	$e + o - 1 \leq \gamma_g \leq e + o$	$e + o \leq \gamma'_g \leq e + o + 1$	(5.9),(5.10*)	(5.12*), (5.11)
$(e, -)$	$(o, +)$	$e + o - 1 \leq \gamma_g \leq e + o$	$e + o \leq \gamma'_g \leq e + o + 1$	(5.9),(5.10*)	(5.12*), (5.11)
$(e, =)$	$(o, =)$	$e + o - 1 \leq \gamma_g \leq e + o$	$e + o \leq \gamma'_g \leq e + o + 1$	(5.9),(5.6*)	(5.8*), (5.11)
$(o, -)$	$(e, -)$	$e + o - 1 \leq \gamma_g \leq e + o$	$e + o - 2 \leq \gamma'_g \leq e + o - 1$	(5.9),(5.10)	(5.12),(5.11)
$(e_1, =)$	$(e_2, =)$	$e_1 + e_2 \leq \gamma_g \leq e_1 + e_2 + 1$	$e_1 + e_2 - 1 \leq \gamma'_g \leq e_1 + e_2$	(5.5),(5.10)	(5.12),(5.7)
$(e_1, =)$	$(e_2, +)$	$e_1 + e_2 \leq \gamma_g \leq e_1 + e_2 + 1$	$e_1 + e_2 + 1 \leq \gamma'_g \leq e_1 + e_2 + 2$	(5.5),(5.10*)	(5.8*), (5.11)
$(o, =)$	$(e, +)$	$e + o - 1 \leq \gamma_g \leq e + o + 1$	$e + o \leq \gamma'_g \leq e + o + 2$	(5.9),(5.10*)	(5.8),(5.11)
$(o_1, +)$	$(o_2, +)$	$o_1 + o_2 - 1 \leq \gamma_g \leq o_1 + o_2 + 1$	$o_1 + o_2 \leq \gamma'_g \leq o_1 + o_2 + 2$	(5.9),(5.6)	(5.12),(5.7)
$(e_1, +)$	$(e_2, +)$	$e_1 + e_2 \leq \gamma_g \leq e_1 + e_2 + 2$	$e_1 + e_2 + 1 \leq \gamma'_g \leq e_1 + e_2 + 3$	(5.5),(5.10)	(5.8),(5.11)
$(o_1, =)$	$(o_2, =)$	$o_1 + o_2 - 1 \leq \gamma_g \leq o_1 + o_2 + 1$	$o_1 + o_2 - 1 \leq \gamma'_g \leq o_1 + o_2 + 1$	(5.9),(5.10)	(5.12),(5.11)
$(o_1, =)$	$(o_2, +)$	$o_1 + o_2 - 1 \leq \gamma_g \leq o_1 + o_2 + 1$	$o_1 + o_2 \leq \gamma'_g \leq o_1 + o_2 + 2$	(5.9),(5.10*)	(5.12*), (5.11)
$(e, +)$	$(o, +)$	$e + o - 1 \leq \gamma_g \leq e + o + 2$	$e + o \leq \gamma'_g \leq e + o + 3$	(5.9),(5.10)	(5.12),(5.11)

**Table 5.2:** Bounds for general graphs.

Using the inequalities of Theorems 5.8 and 5.13, we get the following results.

**Theorem 5.15** *The bounds from Table 5.2 hold.*

Note that only in the first four cases in Table 5.2 the exact game domination number as well as the Staller-start game domination number are determined, while in the next four cases this is the case for exactly one of these two numbers. In all other cases, the difference between the lower and upper bound is at least one and at most three.

We managed to tighten all these bounds but five, on infinite families of graphs.

Recall that the Cartesian product  $G \square H$  of two graphs  $G$  and  $H$  is the graph with vertex set  $V(G \square H) = \{(u, v) | u \in V(G), v \in V(H)\}$  and edge set

$$E(G \square H) = \{((u_1, v_1), (u_2, v_2)) | (u_1 = u_2 \text{ and } (v_1, v_2) \in E(H)) \\ \text{or } (v_1 = v_2 \text{ and } (u_1, u_2) \in E(G))\}.$$

Table 5.3 gives examples of graphs that tighten all but five bounds. The graphs that are not built from paths and cycles by disjoint unions and/or Cartesian products are represented on Figure 5.4. Examples listed in this

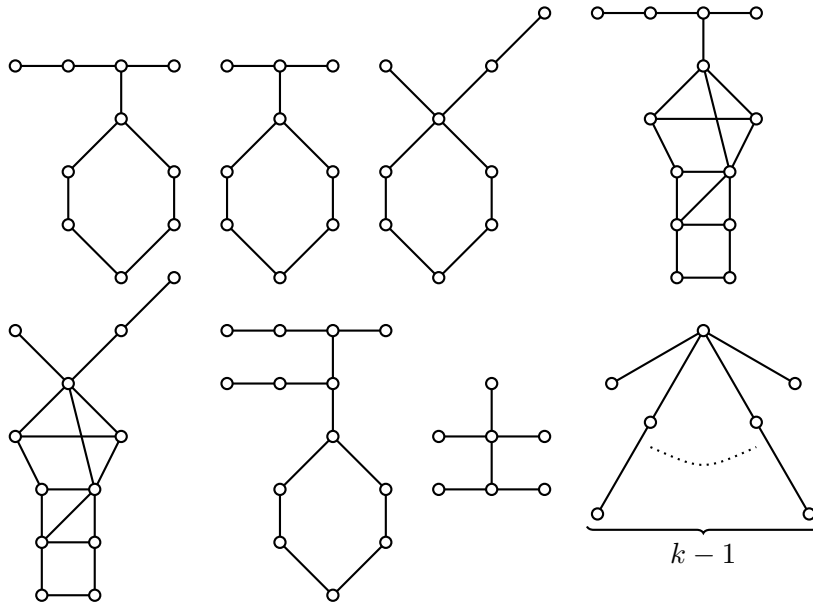
$G_1$	$G_2$	lower on $\gamma_g$	upper on $\gamma_g$	lower on $\gamma'_g$	upper on $\gamma'_g$
$(o_1, -)$	$(o_2, +)$	$C_6 \cup P_3$	$C_6 \cup P_3$	$C_6 \cup P_3$	$C_6 \cup P_3$
$(e_1, -)$	$(e_2, +)$	$P_2 \square P_4 \cup T_2$	$P_2 \square P_4 \cup T_2$	$P_2 \square P_4 \cup T_2$	$P_2 \square P_4 \cup T_2$
$(o_1, -)$	$(o_2, -)$	$C_6 \cup C_6$	$C_6 \cup C_6$	$C_6 \cup C_6$	$C_6 \cup C_6$
$(e_1, -)$	$(e_2, -)$	$P_2 \square P_4 \cup P_2 \square P_4$	$P_2 \square P_4 \cup P_2 \square P_4$	$P_2 \square P_4 \cup P_2 \square P_4$	$P_2 \square P_4 \cup P_2 \square P_4$
$(o_1, =)$	$(o_2, -)$	$K_1 \cup C_6$	$K_1 \cup C_6$	?	$K_1 \cup C_6$
$(e_1, =)$	$(e_2, -)$	$P_8 \cup P_2 \square P_4$	$sp \cup P_2 \square P_4$	$P_8 \cup P_2 \square P_4$	$sp \cup P_2 \square P_4$
$(e, =)$	$(o, -)$	$NE \cup C_6$	$P_8 \cup C_6$	$P_8 \cup C_6$	$P_8 \cup C_6$
$(o, =)$	$(e, -)$	$P_{10} \cup P_2 \square P_4$	?	$P_{10} \cup P_2 \square P_4$	$P_{10} \cup P_2 \square P_4$
$(e, =)$	$(o, +)$	$NE \cup W$	no-minus	$NE \cup W$	no-minus
$(o, -)$	$(e, +)$	$C_6 \cup BLPK$	$C_6 \cup T_4$	$C_6 \cup BLPK$	$C_6 \cup T_4$
$(e, -)$	$(o, +)$	$P_2 \square P_4 \cup P_{11}$	$P_2 \square P_4 \cup PCs$	$P_2 \square P_4 \cup P_{11}$	$P_2 \square P_4 \cup PCs$
$(e, =)$	$(o, =)$	$NE \cup P_6$	$sp \cup BLCK$	$NE \cup P_6$	$sp \cup BLCK$
$(o, -)$	$(e, -)$	$C_6 \cup (3P_2 \square P_4)$	$(3C_6) \cup P_2 \square P_4$	$C_6 \cup (3P_2 \square P_4)$	$(3C_6) \cup P_2 \square P_4$
$(e_1, =)$	$(e_2, =)$	$NE \cup NE$	$sp \cup sp$	?	$sp \cup sp$
$(e_1, =)$	$(e_2, +)$	no-minus	$sp \cup T_4$	no-minus	$sp \cup T_4$
$(o, =)$	$(e, +)$	$CPP \cup BLPK$	$K_1 \cup BLP$	$CPP \cup BLPK$	$K_1 \cup BLP$
$(o_1, +)$	$(o_2, +)$	$PC \cup PC$	$T_5 \cup T_5$	$PC \cup PC$	$T_5 \cup T_5$
$(e_1, +)$	$(e_2, +)$	$BLPK \cup BLPK$	$BLP \cup BLP$	$BLPK \cup BLPK$	$BLP \cup BLP$
$(o_1, =)$	$(o_2, =)$	$CPP \cup CPP$	?	?	$NEsp \cup NEsp$
$(o_1, =)$	$(o_2, +)$	$BLCK \cup PC$	$BLCK \cup PCs$	$BLCK \cup PC$	$BLCK \cup PCs$
$(e, +)$	$(o, +)$	$BLWK \cup PC$	$T_4 \cup (C_6 \cup P_3)$	$BLWK \cup PC$	$T_4 \cup (C_6 \cup P_3)$

**Table 5.3:** Examples of graphs that tighten bounds.

table are small and can be verified by hand or programming. To get bigger examples, one can just add an even number of isolated vertices to one or both of the components. When the bound in general is the same as for no-minus graphs, we just wrote ‘no-minus’ as we know they yield examples reaching the bound.

The following graphs with pairs they realise are used in Table 5.3 as examples that make bounds in Table 5.2 tight.

- $PC$  is  $(5, +)$
- $PCs$  is  $(3, +)$
- $sp$  is  $(4, =)$
- $NE$  is  $(6, =)$
- $NEsp$  is  $(5, =)$
- $CPP$  is  $(7, =)$
- $T_k$  is  $(k, +)$
- $BLP = P_3 \cup P_2 \square P_4$  is  $(4, +)$
- $BLC = P_2 \square P_4 \cup C_6$  is  $(6, =)$
- $BLCK = P_2 \square P_4 \cup C_6 \cup K_1$  is  $(7, =)$
- $BLPK = P_2 \square P_4 \cup P_3 \cup K_1$  is  $(6, +)$
- $BLWK = P_2 \square P_4 \cup W \cup K_1$  is  $(8, +)$



**Figure 5.4:** From top to bottom, left to right:  $PC$ ,  $PCs$ ,  $sp$ ,  $NE$ ,  $NEsp$ ,  $CPP$ ,  $W$ ,  $T_k$

### 5.3 Perspectives

In this chapter, we looked at the domination game.

First, we took an interest in no-minus graphs, that are graphs in which no player ever gets any advantage passing, no matter which set of vertices is dominated. We proved that both tri-split graphs and dually chordal graphs are no-minus graphs. Chordal graphs are another generalisation of split graphs, interval graphs and forests, so we pose the following conjecture.

**Conjecture 5.16** *Partially dominated chordal graphs are no-minus graphs.*

The classes of graphs that we proved to be no-minus are recognisable in polynomial time. Hence the following question is natural.

**Question 5.17** *Can no-minus graphs be recognised in polynomial time?*

Note that a naive algorithm that would consist in checking the values of  $\gamma_g$  and  $\gamma'_g$  would not work. First because no polynomial algorithm is known to compute  $\gamma_g$  or  $\gamma'_g$ . And second because we would have to compute these values for all sets of initially-dominated vertices of the graph, and there are an exponential number of such sets.

Then we considered the game played on disjoint unions of graphs, where we bounded the possible values of  $\gamma_g$  and  $\gamma'_g$ . Notice that our results hold

even when the graphs are not connected, so they can be applied recursively, though then the difference between the lower bound and the upper bound may increase. Note that the strategy we propose is not always optimal, however we think it gives the optimal bound in general.

**Conjecture 5.18** *All bounds from Table 5.2 are tight.*

## Chapter 6

# Conclusion

This thesis has examined games under both normal and misère convention, and even a graph parameter seen as a game.

In Chapter 2, we studied two impartial games under normal convention. The first is a generalisation of ADJACENT NIM, close to VERTEX NIMG, but which forces the players to lower all the weights to 0. We found a polynomial-time algorithm that gives the outcome of a large class of positions, and as our class is closed under followers, this lets us find a strategy for the winning player. Nevertheless, we did not solve the problem entirely. It would be interesting to find an efficient algorithm that would solve the general problem on directed graphs where the self-loops are optional. The problem on directed graphs with no self-loop is not closed under followers, so we do not think it is the right problem to look at first.

The second impartial game we studied can be seen as a generalisation of NIM, as there is a bijection between NIM positions and orientations of subdivided stars where all arcs are directed away from the center, but was actually derived from TOPPLING DOMINOES, through a version where only paths were considered. We found the outcome of any position on a connected directed graph, and the algorithm is actually able to keep track of ‘equivalent’ arcs throughout the reduction, so it is possible to backtrack any winning arc from a minimal position to the original directed graph. As the game does not split in different components, we could be satisfied with this result, but it still feels like the game is not solved yet until one find a way to give the Grundy-value of any position. We partially answered this question by giving a cubic-time algorithm that finds the Grundy-value of any orientation of a path. However, it would be interesting to have a more efficient algorithm that gives such Grundy-values, even for orientations of paths only.

In Chapter 3, we studied three partizan games under normal convention. The first is a generalisation of TIMBER, that we studied in Chapter 2. We gave polynomial-time algorithms to find the outcome of any orientation of paths with coloured arcs, and of any connected directed graph with arcs coloured black or white. Notwithstanding, the general problem is far from solved. Even though the game does not split in different components, we do not know of an efficient algorithm that would give the outcome of any coloured connected directed graph. Finding the value of a position, even on orientations of paths, seems like a hard problem, especially since there could be many different values.

The second partizan game we studied is a coarsening of the first (though it was defined earlier). The interest of our study was to characterise positions having some values, or prove the existence of some values, on positions on a single row. We completely characterised the positions on a single row having value  $\{a|b\}$  with  $a \geq b$ , and provided examples of positions on a single row having value  $\{a|\{b|c\}\}$  for  $a \geq b \geq c$  or  $\{\{a|b\}|\{c|d\}\}$  for  $a \geq b > c \geq d$ . It would be interesting to complete the characterisation of these last two sets of positions. Other interesting conjectures on the game can be found in [17].

The last partizan game we looked at is a colouring game. Though any position on a grey graph has value 0 or  $*$ , and the value of other positions is restricted to numbers and sums of numbers and  $*$ , finding the outcome of a position is quite complex. We gave the outcomes of grey positions belonging to some subclasses of trees, and the outcomes of grey cographs. It would be interesting to find an algorithm that would give the outcome of any grey tree, and maybe put it together with the algorithm we propose for grey cographs to find the outcome of any distance-hereditary graph.

In Chapter 4, we switched to the *misère* convention. First, we described the *misère* version of the games we studied earlier. We provided results on a complexity level as well as on finding algorithms that give the outcome of position, and results on reducing the problem to positions that seem simpler. There are games on which we did not say much, but the *misère* version of a game is in general harder to solve than its normal version, as highlighted with VERTEX GEOGRAPHY, where one can find the normal outcome of any position on an undirected graph  $G$  in time  $O(|E(G)|\sqrt{|V(G)|})$  whereas finding the *misère* outcome of a position, even on planar undirected graphs of maximum degree 5, is PSPACE-complete. In contrast, we gave a solution to find the *misère* outcome of any LR-TOPPLING DOMINOES position in a linear time. However, there is still a lot to search on the general version of TOPPLING DOMINOES under *misère* convention, where we allow grey dominoes. The other games we studied are not completely solved either, and could be subject to future research.

Then we looked at *misère* universes. The first we consider is a well-known set of games. Under the normal convention, these games are called all-small because they all are infinitesimal, that is they are smaller than any positive number and greater than any negative number. Under the *misère* convention, we gave them a canonical form. However, there is no efficient way to compute this canonical form as it requires to detect dominated and reversible options, and we do not know of an efficient way of comparing any two games. In practice, though, there are situations where it is possible to compare games, and we hope our analysis of games born by day 3 can help in the endgames of dicot positions.

Next, we looked at a second universe in *misère* play. Though this universe is somehow new, it contains many games that have been studied before. In

particular, it contains the universe of dicot games, studied in the previous section. We analysed ends and numbers. Ends might appear quite often in games, but numbers in normal canonical form are less frequent. Nonetheless, it is still interesting to know there are quite many games admitting an inverse modulo the dead-ending universe, and that even some games not being of this kind of sum are equivalent to 0 in this universe.

In Chapter 5, we left combinatorial games to study the domination game. We found some classes of graphs where the analysis should be easier, and looked at what value the parameter of the disjoint union of two graphs may have considering the values of the parameter of these two graphs and the process can be repeated on more than two components. It is interesting to see how this vision from combinatorial games, seeing the game as a disjunctive sum, helps highlighting how interesting no-minus graphs are for the domination game. We also used the imagination strategy which, without being defined as a combinatorial games tool, may remind us of the stealing strategy argument used to find the winning player in some combinatorial games. No-minus graphs are interesting because they are somewhat more predictable, so it would be nice to be able to characterise them, or find other classes of graphs having this property.





## Appendix A

# Appendix: Rule sets

- **CLOBBER** is a partizan game played on an undirected graph with vertices coloured black or white. At her turn, Left chooses a white vertex she colours black and a black vertex she removes from the game provided the two vertices were adjacent. At his turn, Right chooses a black vertex he colours white and a white vertex he removes from the game provided the two vertices were adjacent.
- **COL** is a partizan game played on an undirected graph with vertices either uncoloured or coloured black or white. A move of Left consists in choosing an uncoloured vertex and colouring it black, while a move of Right would be to do the same with the colour white. An extra condition is that the partial colouring has to stay proper, that is no two adjacent vertices should have the same colour. Another way of seeing the game is to play it on the graph of available moves: a position is an undirected graph with all vertices coloured black, white or grey; a move of Left is to choose a black or grey vertex, remove it from the game with all its black coloured neighbours, and change the colour of its other neighbours to white; a move of Right is to choose a white or grey vertex, remove it from the game with all its white coloured neighbours, and change the colour of its other neighbours to black.
- **DOMINEERING** is a partizan game played on a square grid, where some vertices might be missing. A move of Left consists in choosing two vertically adjacent vertices and remove them from the game, while a Right move is to choose two horizontally adjacent vertices and remove them from the game. The game is usually represented with a grid of squares where players put dominoes without superimposing them.
- **FLIP THE COIN** is a partizan game played on one or several rows of coins, each coin facing either heads or tails. At her turn, Left chooses a coin facing heads and removes it from the game, flipping the coins adjacent to it. At his turn, Right does the same with a coin facing tail. There exists a variant where the two neighbours of the coin removed become adjacent.
- **GEOGRAPHY** is an impartial game played on a directed graph with a token on a vertex. There exist two variants of the game: **VERTEX GEOGRAPHY** and **EDGE GEOGRAPHY**. A move in **VERTEX GEOGRAPHY** is to slide the token through an arc and delete the vertex on which the token was. A move in **EDGE GEOGRAPHY** is to slide the token

through an arc and delete the edge on which the token just slid. In both variants, the game ends when the token is on an isolated vertex. GEOGRAPHY can also be played on an undirected graph  $G$  by seeing it as a symmetric directed graph where the vertex set remains the same and the arc set is  $\{(u, v), (v, u) | (u, v) \in E(G)\}$ , except that in the case of EDGE GEOGRAPHY, going through an edge  $(u, v)$  would remove both the arc  $(u, v)$  and the arc  $(v, u)$  of the directed version.

- **HACKENBUSH** is a partizan game played on a graph with arcs coloured black, white, or grey, and a special vertex called the ground. At her turn, Left removes a grey or black edge from the game, and everything that is no longer connected to the ground falls down (is removed from the game). At his turn, Right does the same with a grey or white edge.
- **HEX** is a partizan game played on a hexagonal grid. At her turn, Left places a black piece on an empty vertex, and Right does the same at his turn with a white piece. The game ends when there is a path of black stones connecting the upper-left side to the lower-right side of the board, or a path of white stone connecting the upper-right side to the lower-left side of the board.
- **NIM** is an impartial game played on one or several heaps of tokens. At their turn, a player removes any positive number of tokens from one single heap they choose.
- **Octal games** are impartial games played on one or several heaps of tokens. The possible moves of an octal game are given by its octal code  $d_0.d_1d_2\dots$ , where  $d_i$  range between 0 and 7. At their move, a player may remove  $i$  tokens from a heap if either the heap is of size  $i$  and  $d_i$  is odd, or if the heap is of size greater than  $i$  and  $d_i$  is congruent to 2 or 3 modulo 4. They might even split a heap into two non-empty heap, removing  $i$  tokens if  $d_i$  is at least 4. Note that  $d_0$  may only have value 0 or 4.
- **PEG DUOTAIRE** is an impartial game played on a grid, with pegs on some vertices. On a move, a player hops a peg over another one, provided they are adjacent, and landing right on the other side of it, and removes the second peg from the game.
- **PARTIZAN PEG DUOTAIRE** is an impartial game played on a square grid, with pegs on some vertices. On her move, Left hops a peg over another one, provided they are vertically adjacent, and landing right on the other side of it, and removes the second peg from the game. On his move, Right hops a peg over another one, provided they are horizontally adjacent, and landing right on the other side of it, and removes the second peg from the game.
- **SHE LOVES MOVE, SHE LOVES ME NOT** is the name of the octal game 0.3, which is equivalent to the octal game 0.7.
- **SNORT** is a partizan game played on an undirected graph with vertices

either uncoloured or coloured black or white. A move of Left consists in choosing an uncoloured vertex and colouring it black, while a move of Right would be to do the same with the colour white. An extra condition is that no two adjacent vertices should have different colours. Another way of seeing the game is to play it on the graph of available moves: a position is an undirected graph with all vertices coloured black, white or grey; a move of Left is to choose a black or grey vertex, remove it from the game with all its white coloured neighbours, and change the colour of its other neighbours to black; a move of Right is to choose a white or grey vertex, remove it from the game with all its black coloured neighbours, and change the colour of its other neighbours to white.

- **TIMBER** is an impartial game played on a directed graph. On a move, a player chooses an arc  $(x, y)$  of the graph and removes it along with all that is still connected to the endpoint  $y$  in the underlying undirected graph where the arc  $(x, y)$  has already been removed. Another way of seeing it is to put a vertical domino on every arc of the directed graph, and consider that if one domino is toppled, it topples the dominoes in the direction it was toppled and creates a chain reaction. The direction of the arc indicates the direction in which the domino can be initially toppled, but has no incidence on the direction it is toppled, or on the fact that it is toppled, if a player has chosen to topple a domino which will eventually topple it.
- **TIMBUSH** is the natural partizan extension of TIMBER, played on a directed graph with arcs coloured black, white, or grey. On her move, Left chooses a black or grey arc  $(x, y)$  of the graph and removes it along with all that is still connected to the endpoint  $y$  in the underlying undirected graph. On his move, Right does the same with a white or grey arc.
- **TOPPLING DOMINOES** is a partizan game played on one or several rows of dominoes coloured black, white, or grey. On her move, Left chooses a black or grey domino and topples it with all dominoes (of the same row) at its left, or with all dominoes (of the same row) at its right. On his turn, Right does the same with a white or grey domino.
- **VERTEXNIM** is an impartial game played on a weighted strongly-connected directed graph with a token on a vertex. On a move, a player decreases the weight of the vertex where the token is and slides the token along a directed edge. When the weight of a vertex  $v$  is set to 0,  $v$  is removed from the graph and all the pairs of arcs  $(p, v)$  and  $(v, s)$  (with  $p$  and  $s$  not necessarily distinct) are replaced by an arc  $(p, s)$ .

VERTEXNIM can also be played on a connected undirected graph  $G$  by seeing it as a symmetric directed graph where the vertex set remains the same and the arc set is  $\{(u, v), (v, u) \mid (u, v) \in E(G)\}$ .

- **VERTEX NIMG** is an impartial game played on a weighted directed graph with a token on a vertex. There exist two variants of the game, the Move then Remove version and the Remove then Move version. In the Move then Remove version, a player's move is to slide the token through an arc and then decrease the weight of the vertex on which they moved the token to. In the Remove then Move version, a player's move is to decrease the weight of the vertex where the token is and then slide the token through an arc. When the weight of a vertex is set to 0, the vertex is removed from the game. In the Remove then Move version, there is a variant where it is still possible to move to vertices of weight 0, ending the game as no move is possible from there.

## Appendix B

# Appendix: Omitted proofs

---

### B.1 Proof of Theorem 3.30

---

**Theorem 3.30** *If  $a \geq b \geq c$  are numbers, then  $\mathbf{aLRcRLb}$  has value  $\{a|\{b|c\}\}$ . Moreover, if  $a > b$ , then  $\mathbf{aEcRLb}$  also has value  $\{a|\{b|c\}\}$ .*

We cut the proof into two claims, one proving  $\mathbf{aLRcRLb}$  has value  $\{a|\{b|c\}\}$ , the other proving  $\mathbf{aEcRLb}$  has value  $\{a|\{b|c\}\}$ .

We start by proving  $\mathbf{aLRcRLb}$  has value  $\{a|\{b|c\}\}$ . We first prove some preliminary lemmas on options of  $\mathbf{aLRcRLb}$ .

**Lemma B.1** *Let  $a, b$  be numbers such that  $a \geq b$ . For any Right option  $\mathbf{b}^R$  obtained from  $\mathbf{b}$  toppling rightward and any Right option  $\mathbf{a}^R$  obtained from  $\mathbf{a}$  toppling leftward, we have  $\mathbf{a}^R\mathbf{LRb}^R > b$ .*

**Proof.** We prove that Left has a winning strategy in  $\mathbf{a}^R\mathbf{LRb}^R - b$  whoever plays first. When Left starts, she can move to  $\mathbf{a}^R - b$ , which is positive. Now consider the case when Right starts, and his possible moves from  $\mathbf{a}^R\mathbf{LRb}^R - b$ . If Right plays in  $-b$ , we get

- $\mathbf{a}^R\mathbf{LRb}^R + (-b)^R$ . Recall that since  $b$  is taken in its canonical form, there is only one Right option to  $-b$ , namely  $(-b)^{R_0}$ . Here Left can answer to  $\mathbf{a}^R + (-b)^{R_0}$ , which is positive.

Consider now Right's possible moves in  $\mathbf{a}^R\mathbf{LRb}^R$ . Toppling rightward, Right can move to:

- $(\mathbf{a}^R)^R - b$ , positive.
- $\mathbf{a}^R\mathbf{L} - b$ , positive as  $\mathbf{a}^R\mathbf{L} > \mathbf{a}^R > a$ .
- $\mathbf{a}^R\mathbf{LR}(\mathbf{b}^R)^R - b$ . Then Left can answer to  $\mathbf{a}^R - b$ , which is positive.

Toppling leftward, Right can move to:

- $(\mathbf{a}^R)^R\mathbf{LRb}^R - b$ . Then Left can answer to  $(\mathbf{a}^R)^R - b$ , which is positive.
- $\mathbf{b}^R - b$ , positive.
- $(\mathbf{b}^R)^R - b$ , positive.

□

**Lemma B.2** *Let  $a, b, c$  be numbers such that  $a > b \geq c$ . For any Right option  $\mathbf{b}^R$  obtained from  $\mathbf{b}$  toppling rightward, we have  $\mathbf{aLRcRLb}^R > \{b|c\}$ .*

**Proof.** We prove that Left has a winning strategy in  $\mathbf{aLRcRLb}^R - \{b|c\}$  whoever plays first. When Left starts, she can move to  $a - \{b|c\}$ , which is

positive. Now consider the case when Right starts, and his possible moves from  $\mathbf{aLRcRLb}^R - \{b|c\}$ . If Right plays in  $-\{b|c\}$ , we get

- $\mathbf{aLRcRLb}^R - b$ . Then Left can answer to  $\mathbf{a} - b$ , which is positive.

Consider now Right's possible moves in  $\mathbf{aLRcRLb}^R$ . Toppling rightward, Right can move to:

- $\mathbf{a}^R - \{b|c\}$ , positive.
- $\mathbf{aL} - \{b|c\}$ , positive.
- $\mathbf{aLRc}^R - \{b|c\}$ , positive as  $\mathbf{aLRc}^R > \{a|c\} > \{b|c\}$ .
- $\mathbf{aLRc} - \{b|c\}$ , positive.
- $\mathbf{aLRcRL}(\mathbf{b}^R)^R - \{b|c\}$ . Then Left can answer to  $(\mathbf{b}^R)^R - \{b|c\}$ , which is positive by Corollary 3.34

Toppling leftward, Right can move to:

- $\mathbf{a}^R\mathbf{LRcRLb}^R - \{b|c\}$ . Then Left can answer to  $\mathbf{a}^R - \{b|c\}$ , which is positive.
- $\mathbf{cRLb}^R - \{b|c\}$ , positive by Lemma 3.39
- $\mathbf{c}^R\mathbf{RLb}^R - \{b|c\}$ . Then Left can answer to  $\mathbf{c}^R\mathbf{RLb}^R - c$ , which is positive by Lemma B.1
- $\mathbf{Lb}^R - \{b|c\}$ , positive by Corollary 3.34
- $(\mathbf{b}^R)^R - \{b|c\}$ , positive by Corollary 3.34

□

**Lemma B.3** *Let  $a, b, c$  be numbers such that  $a > b \geq c$ . For any Left option  $\mathbf{a}^L$  obtained from  $\mathbf{a}$  toppling leftward, we have  $\mathbf{a}^L\mathbf{LRcRLb} < a$ .*

**Proof.** We prove that Right has a winning strategy in  $\mathbf{a}^L\mathbf{LRcRLb} - a$  whoever plays first. When Right starts, he can move to  $\mathbf{cRLb} - a$ , which is negative. Now consider the case when Left starts, and her possible moves from  $\mathbf{a}^L\mathbf{LRcRLb} - a$ . If Left plays in  $-a$ , we get

- $\mathbf{a}^L\mathbf{LRcRLb} + (-a)^{L_0}$ . Then Right can answer to  $\mathbf{cRLb} + (-a)^{L_0}$ , which is negative.

Consider now Left's possible move in  $\mathbf{cRLb}$ . Toppling rightward, Left can move to:

- $(\mathbf{a}^L)^L - a$ , negative.
- $\mathbf{a}^L - a$ , negative.
- $\mathbf{a}^L\mathbf{LRc}^L - a$ . Then Right can answer to  $\mathbf{c}^L - a$ , which is negative.
- $\mathbf{a}^L\mathbf{LRcR} - a$ . Then Right can answer to  $\mathbf{cR} - a$ , which is negative.
- $\mathbf{a}^L\mathbf{LRcRLb}^L - a$ . Then Right can answer to  $\mathbf{a}^L\mathbf{LRc} - a$ , which is negative by Lemma 3.35.

Toppling leftward, Left can move to:

- $(\mathbf{a}^L)^L\mathbf{LRcRLb} - a$ . Then Right can answer to  $\mathbf{cRLb} - a$ , which is negative.
- $\mathbf{RcRLb} - a$ , negative.
- $\mathbf{c}^L\mathbf{RLb} - a$ . Then Right can answer to  $\mathbf{c}^L - a$ , which is negative.

- $\mathbf{b} - a$ , negative.
- $\mathbf{b}^L - a$ , negative.

□

**Lemma B.4** *Let  $a, b, c$  be numbers such that  $a \geq b \geq c$ . For any Left option  $\mathbf{b}^L$  obtained from  $\mathbf{b}$  toppling rightward, we have  $\mathbf{cRLb}^L < \{a|\{b|c\}\}$ .*

**Proof.** We prove that Right has a winning strategy in  $\mathbf{cRLb}^L - \{a|\{b|c\}\}$  whoever plays first. When Right starts, he can move to  $\mathbf{c} - \{a|\{b|c\}\}$ , which is negative. Now consider the case when Left starts, and her possible moves from  $\mathbf{cRLb}^L - \{a|\{b|c\}\}$ . If Left plays in  $-\{a|\{b|c\}\}$ , we get

- $\mathbf{cRLb}^L - \{b|c\}$ , negative by Lemma 3.40.

Consider now Right's possible moves in  $\mathbf{cRLb}^L$ . Toppling rightward, Left can move to:

- $\mathbf{c}^L - \{a|\{b|c\}\}$ . Then Right can answer to  $\mathbf{c}^L - a$ , which is negative.
- $\mathbf{cR} - \{a|\{b|c\}\}$ . Then Right can answer to  $\mathbf{cR} - a$ , which is negative.
- $\mathbf{cRL}(\mathbf{b}^L)^L - \{a|\{b|c\}\}$ . Then Right can answer to  $\mathbf{cRL}(\mathbf{b}^L)^L - a$ , which is negative by Lemma 3.35.

Toppling leftward, Left can move to:

- $\mathbf{c}^L\mathbf{RLb}^L - \{a|\{b|c\}\}$ . Then Right can answer to  $\mathbf{c}^L\mathbf{RLb}^L - a$ , which is negative by Lemma B.1.
- $\mathbf{b}^L - \{a|\{b|c\}\}$ . Then Right can answer to  $\mathbf{b}^L - a$ , which is negative.
- $(\mathbf{b}^L)^L - \{a|\{b|c\}\}$ . Then Right can answer to  $(\mathbf{b}^L)^L - a$ , which is negative.

□

We can now prove the following claim.

**Claim B.5** *Let  $a, b, c$  be numbers such that  $a \geq b \geq c$ . We have  $\mathbf{aLRcRLb} = \{a|\{b|c\}\}$ .*

**Proof.** We prove that the second player has a winning strategy in  $\mathbf{aLRcRLb} - \{a|\{b|c\}\}$ . Consider first the case where Right starts and his possible moves from  $\mathbf{aLRcRLb} - \{a|\{b|c\}\}$ . If Right plays in  $-\{a|\{b|c\}\}$ , we get

- $\mathbf{aLRcRLb} - a$ . Then Left can answer to  $\mathbf{a} - a$  which has value 0.

Consider now Right's possible moves in  $\mathbf{aLRcRLb}$ . Toppling leftward, Right can move to:

- $\mathbf{a}^R\mathbf{LRcRLb} - \{a|\{b|c\}\}$ . Then Left can answer to  $\mathbf{a}^R - \{a|\{b|c\}\}$ , which is positive.
- $\mathbf{cRLb} - \{a|\{b|c\}\}$ . Then Left can answer to  $\mathbf{cRLb} - \{b|c\}$  which has value 0.
- $\mathbf{c}^R\mathbf{RLb} - \{a|\{b|c\}\}$ . Then Left can answer to  $\mathbf{c}^R\mathbf{RLb} - \{b|c\}$ , which is positive by Lemma 3.40.

- $\mathbf{Lb} - \{a|\{b|c\}\}$ . Then Left can answer to  $\mathbf{Lb} - \{b|c\}$ , which is positive by Corollary 3.34.
- $\mathbf{b}^R - \{a|\{b|c\}\}$ . Then Left can answer to  $\mathbf{b}^R - \{b|c\}$ , which is positive by Corollary 3.34.

Toppling rightward, Right can move to:

- $\mathbf{a}^R - \{a|\{b|c\}\}$ , positive.
- $\mathbf{aL} - \{a|\{b|c\}\}$ , positive.
- $\mathbf{aLRc}^R - \{a|\{b|c\}\}$ . Then Left can answer to  $\mathbf{aLRc}^R - \{b|c\}$ , which is positive by Lemma 3.40.
- $\mathbf{aLRc} - \{a|\{b|c\}\}$ . Then Left can answer to  $\mathbf{aLRc} - \{b|c\}$ , which is positive if  $a > b$ , and has value 0 if  $a = b$ .
- $\mathbf{aLRcRLb}^R - \{a|\{b|c\}\}$ . Then Left can answer to  $\mathbf{aLRcRLb}^R - \{b|c\}$ , which is positive when  $a > b$  by Lemma B.2, or to  $\mathbf{b}^R - \{a|\{b|c\}\}$ , which is positive when  $a = b$ .

Now consider the case where Left starts and her possible moves from  $\mathbf{aLRcRLb} - \{a|\{b|c\}\}$ . If Left plays in  $-\{a|\{b|c\}\}$ , we get

- $\mathbf{aLRcRLb} - \{b|c\}$ . Then Right can answer to  $\mathbf{cRLb} - \{b|c\}$  which has value 0.

Consider now Left's possible move in  $\mathbf{aLRcRLb}$ . Toppling rightward, Left can move to:

- $\mathbf{aLRcRLb}^L - \{a|\{b|c\}\}$ . Then Right can answer to  $\mathbf{cRLb}^L - \{a|\{b|c\}\}$ , which is negative by Lemma B.4.
- $\mathbf{aLRcR} - \{a|\{b|c\}\}$ . Then Right can answer to  $\mathbf{cR} - \{a|\{b|c\}\}$ , which is negative.
- $\mathbf{aLRc}^L - \{a|\{b|c\}\}$ . Then Right can answer to  $\mathbf{c}^L - \{a|\{b|c\}\}$ , which is negative.
- $\mathbf{a} - \{a|\{b|c\}\}$ . Then Right can answer to  $\mathbf{a} - a$  which has value 0.
- $\mathbf{a}^L - \{a|\{b|c\}\}$ . Then Right can answer to  $\mathbf{a}^L - a$ , which is negative.

Toppling leftward, Left can move to:

- $\mathbf{b}^L - \{a|\{b|c\}\}$ . Then Right can answer to  $\mathbf{b}^L - a$ , which is negative.
- $\mathbf{b} - \{a|\{b|c\}\}$ . Then Right can answer to  $\mathbf{b} - a$ , which is negative.
- $\mathbf{c}^L\mathbf{RLb} - \{a|\{b|c\}\}$ . Then Right can answer to  $\mathbf{c}^L - \{a|\{b|c\}\}$ , which is negative.
- $\mathbf{RcRLb} - \{a|\{b|c\}\}$ . Then Right can answer to  $\mathbf{Rc} - \{a|\{b|c\}\}$ , which is negative.
- $\mathbf{a}^L\mathbf{LRcRLb} - \{a|\{b|c\}\}$ . Then Right can answer to  $\mathbf{a}^L\mathbf{LRcRLb} - a$ , which is negative by Lemma B.3 when  $a > b$ , or to  $\mathbf{a}^L\mathbf{LRc} - \{a|\{b|c\}\}$ , which is negative by Lemma B.4 when  $a = b$ .

□

As an example, here is a representation of  $\{-1|\{-\frac{7}{4}| - 2\}\}$ :





We now prove that  $\mathbf{aEcRLb}$  has value  $\{a|\{b|c\}\}$ . Again, we first prove some preliminary lemmas on options of  $\mathbf{aEcRLb}$ .

**Lemma B.6** *Let  $a, b, c$  be numbers such that  $a > b \geq c$ . For any Right option  $\mathbf{b}^R$  obtained from  $\mathbf{b}$  toppling rightward, we have  $\mathbf{aEcRLb}^R > \{b|c\}$ .*

**Proof.** We prove that Left has a winning strategy in  $\mathbf{aEcRLb}^R - \{b|c\}$  whoever plays first. When Left starts, she can move to  $\mathbf{b}^R - \{b|c\}$ , which is positive by Corollary 3.34. Now consider the case when Right starts, and his possible moves from  $\mathbf{aEcRLb}^R - \{b|c\}$ . If Right plays in  $-\{b|c\}$ , we get

- $\mathbf{aEcRLb}^R - b$ . Then Left can answer to  $\mathbf{a} - b$ , which is positive.

Consider now Right's possible moves in  $\mathbf{aEcRLb}^R$ . Toppling rightward, Right can move to:

- $\mathbf{a}^R - \{b|c\}$ , positive.
- $\mathbf{a} - \{b|c\}$ , positive.
- $\mathbf{aEc}^R - \{b|c\}$ . Then Left can answer to  $\mathbf{a} - \{b|c\}$ , which is positive.
- $\mathbf{aEc} - \{b|c\}$ , positive.
- $\mathbf{aEcRL}(\mathbf{b}^R)^R - \{b|c\}$ . Then Left can answer to  $(\mathbf{b}^R)^R - \{b|c\}$ , which is positive by Corollary 3.34.

Toppling leftward, Right can move to:

- $\mathbf{a}^R\mathbf{EcRLb}^R - \{b|c\}$ . Then Left can answer to  $\mathbf{a}^R - \{b|c\}$ , which is positive.
- $\mathbf{cRLb}^R - \{b|c\}$ . Then Left can answer to  $\mathbf{b}^R - \{b|c\}$ , which is positive by Corollary 3.34.
- $\mathbf{c}^R\mathbf{RLb}^R - \{b|c\}$ . Then Left can answer to  $\mathbf{b}^R - \{b|c\}$ , which is positive by Corollary 3.34.
- $L\mathbf{b}^R - \{b|c\}$ , positive by Corollary 3.34.
- $(\mathbf{b}^R)^R - \{b|c\}$ , positive by Corollary 3.34.

□

**Lemma B.7** *Let  $a, b, c$  be numbers such that  $a > b \geq c$ . For any Left option  $\mathbf{a}^L$  obtained from  $\mathbf{a}$  toppling leftward, we have  $\mathbf{a}^L\mathbf{EcRLb} < a$ .*

**Proof.** We prove that Right has a winning strategy in  $\mathbf{a}^L\mathbf{EcRLb} - a$  whoever plays first. When Right starts, he can move to  $\mathbf{a}^L - a$ , which is negative. Now consider the case when Left starts, and her possible moves from  $\mathbf{a}^L\mathbf{EcRLb} - a$ . If Left plays in  $-a$ , we get

- $\mathbf{a}^L\mathbf{EcRLb} + (-a)^L$ . Then Right can answer to  $\mathbf{cRLb} + (-a)^L$ , which is negative.

Consider now Left's possible moves in  $\mathbf{a}^L\mathbf{EcRLb}$ . Toppling rightward, Left can move to:

- $(\mathbf{a}^L)^L - a$ , negative.
- $\mathbf{a}^L - a$ , negative.
- $\mathbf{a}^L\mathbf{Ec}^L - a$ . Then Right can answer to  $\mathbf{c}^L - a$ , which is negative.

- $\mathbf{a}^L \mathbf{EcR} - a$ . Then Right can answer to  $\mathbf{cR} - a$ , which is negative.
- $\mathbf{a}^L \mathbf{EcRLb}^L - a$ . Then Right can answer to  $\mathbf{a}^L - a$ , which is negative.

Toppling leftward, Left can move to:

- $(\mathbf{a}^L)^L \mathbf{EcRLb} - a$ . Then Right can answer to  $\mathbf{cRLb} - a$ , which is negative.
- $\mathbf{cRLb} - a$ , negative.
- $\mathbf{c}^L \mathbf{RLb} - a$ . Then Right can answer to  $\mathbf{c}^L - a$ , which is negative.
- $\mathbf{b} - a$ , negative.
- $\mathbf{b}^L - a$ , negative.

□

We can now prove the following claim.

**Claim B.8** *Let  $a, b$  be numbers such that  $a > b \geq c$ . We have  $\mathbf{aEcRLb} = \{a|\{b|c\}\}$ .*

**Proof.** We prove that the second player has a winning strategy in  $\mathbf{aEcRLb} - \{a|\{b|c\}\}$ . Consider first the case where Right starts and his possible moves from  $\mathbf{aEcRLb} - \{a|\{b|c\}\}$ . If Right plays in  $-\{a|\{b|c\}\}$ , we get

- $\mathbf{aLRcRLb} - a$ . Then Left can answer to  $\mathbf{a} - a$  which has value 0.

Consider now Right's possible moves in  $\mathbf{aEcRLb}$ . Toppling leftward, Right can move to:

- $\mathbf{a}^R \mathbf{EcRLb} - \{a|\{b|c\}\}$ . Then Left can answer to  $\mathbf{a}^R - \{a|\{b|c\}\}$ , which is positive.
- $\mathbf{cRLb} - \{a|\{b|c\}\}$ . Then Left can answer to  $\mathbf{cRLb} - \{b|c\}$  which has value 0.
- $\mathbf{c}^R \mathbf{RLb} - \{a|\{b|c\}\}$ . Then Left can answer to  $\mathbf{c}^R \mathbf{RLb} - \{b|c\}$  which is positive by Lemma 3.40.
- $\mathbf{Lb} - \{a|\{b|c\}\}$ . Then Left can answer to  $\mathbf{Lb} - \{b|c\}$ , which is positive by Corollary 3.34.
- $\mathbf{b}^R - \{a|\{b|c\}\}$ . Then Left can answer to  $\mathbf{b}^R - \{b|c\}$ , which is positive by Corollary 3.34.

Toppling rightward, Right can move to:

- $\mathbf{a}^R - \{a|\{b|c\}\}$ , positive.
- $\mathbf{a} - \{a|\{b|c\}\}$ , positive.
- $\mathbf{aEc}^R - \{a|\{b|c\}\}$ . Then Left can answer to  $\mathbf{aEc}^R - \{b|c\}$ , which is positive by Lemma 3.42.
- $\mathbf{aEc} - \{a|\{b|c\}\}$ . Then Left can answer to  $\mathbf{aEc} - \{b|c\}$ , which is positive.
- $\mathbf{aEcRLb}^R - \{a|\{b|c\}\}$ . Then Left can answer to  $\mathbf{aEcRLb}^R - \{b|c\}$ , which is positive by Lemma B.6.

Now consider the case where Left starts and her possible moves from  $\mathbf{aEcRLb} - \{a|\{b|c\}\}$ . If Left plays in  $-\{a|\{b|c\}\}$ , we get

- $\mathbf{aEcRLb} - \{b|c\}$ . Then Right can answer to  $\mathbf{cRLb} - \{b|c\}$  which has value 0.

Consider now Left's possible move in  $\mathbf{aEcRLb}$ . Toppling rightward, Left can move to:

- $\mathbf{aEcRLb}^L - \{a|\{b|c\}\}$ . Then Right can answer to  $\mathbf{cRLb}^L - \{a|\{b|c\}\}$ , which is negative by Lemma B.4.
- $\mathbf{aEcR} - \{a|\{b|c\}\}$ . Then Right can answer to  $\mathbf{cR} - \{a|\{b|c\}\}$ , which is negative.
- $\mathbf{aEc}^L - \{a|\{b|c\}\}$ . Then Right can answer to  $\mathbf{c}^L - \{a|\{b|c\}\}$ , which is negative.
- $\mathbf{a} - \{a|\{b|c\}\}$ . Then Right can answer to  $\mathbf{a} - a$  which has value 0.
- $\mathbf{a}^L - \{a|\{b|c\}\}$ . Then Right can answer to  $\mathbf{a}^L - a$ , which is negative.

Toppling leftward, Left can move to:

- $\mathbf{b}^L - \{a|\{b|c\}\}$ . Then Right can answer to  $\mathbf{b}^L - a$ , which is negative.
- $\mathbf{b} - \{a|\{b|c\}\}$ . Then Right can answer to  $\mathbf{b} - a$ , which is negative.
- $\mathbf{c}^L\mathbf{RLb} - \{a|\{b|c\}\}$ . Then Right can answer to  $\mathbf{c}^L - \{a|\{b|c\}\}$ , which is negative.
- $\mathbf{cRLb} - \{a|\{b|c\}\}$ . Then Right can answer to  $\mathbf{c} - \{a|\{b|c\}\}$ , which is negative.
- $\mathbf{a}^L\mathbf{EcRLb} - \{a|\{b|c\}\}$ . Then Right can answer to  $\mathbf{a}^L\mathbf{EcRLb} - a$ , which is negative by Lemma B.7.

□

As an example, here is a representation of  $\{3|\{1|-\frac{3}{2}\}\}$ :




---

## B.2 Proof of Theorem 3.31

---

**Theorem 3.31** *If  $a \geq b > c \geq d$  are numbers, then both  $\mathbf{bRLaLRdRLc}$  and  $\mathbf{bRLaEdRLc}$  have value  $\{\{a|b\}|\{c|d\}\}$ .*

We cut the proof into two claims, one proving  $\mathbf{bRLaLRdRLc}$  has value  $\{\{a|b\}|\{c|d\}\}$ , the other proving  $\mathbf{bRLaEdRLc}$  has value  $\{\{a|b\}|\{c|d\}\}$ .

We start by proving  $\mathbf{bRLaLRdRLc}$  has value  $\{\{a|b\}|\{c|d\}\}$ . We first prove some preliminary lemmas on options of  $\mathbf{bRLaLRdRLc}$ .

**Lemma B.9** *Let  $a, b, c, d$  be numbers such that  $a \geq b > c \geq d$ . For any Right option  $\mathbf{b}^R$  obtained from  $\mathbf{b}$  toppling leftward, we have  $\mathbf{b}^R\mathbf{RLa} > \{\{a|b\}|\{c|d\}\}$ .*

**Proof.** We prove Left has a winning strategy in  $\mathbf{b}^R\mathbf{RLa} - \{\{a|b\}|\{c|d\}\}$  whoever plays first. When Left starts, she can move to  $\mathbf{b}^R\mathbf{RLa} - \{c|d\}$ ,

which is positive by Lemma 3.40. Now consider the case when Right starts, and his possible moves from  $\mathbf{b}^R\mathbf{RLa} - \{\{a|b\}|\{c|d\}\}$ . If Right plays in  $-\{\{a|b\}|\{c|d\}\}$ , we get

- $\mathbf{b}^R\mathbf{RLa} - \{a|b\}$ , positive by Lemma 3.40.

Consider now Right's possible moves in  $\mathbf{b}^R\mathbf{RLa}$ . Toppling rightward, Right can move to:

- $(\mathbf{b}^R)^R - \{\{a|b\}|\{c|d\}\}$ . Then Left can answer to  $(\mathbf{b}^R)^R - \{c|d\}$ , which is positive.
- $\mathbf{b}^R - \{\{a|b\}|\{c|d\}\}$ . Then Left can answer to  $\mathbf{b}^R - \{c|d\}$ , which is positive.
- $\mathbf{b}^R\mathbf{RLa}^R - \{\{a|b\}|\{c|d\}\}$ . Then Left can answer to  $\mathbf{a}^R - \{\{a|b\}|\{c|d\}\}$ , which is positive.

Toppling leftward, Right can move to:

- $(\mathbf{b}^R)^R\mathbf{RLa} - \{\{a|b\}|\{c|d\}\}$ . Then Left can answer to  $\mathbf{a} - \{\{a|b\}|\{c|d\}\}$ , which is positive.
- $\mathbf{La} - \{\{a|b\}|\{c|d\}\}$ , positive.
- $\mathbf{a}^R - \{\{a|b\}|\{c|d\}\}$ , positive.

□

**Lemma B.10** *Let  $a, b, c, d$  be numbers such that  $a \geq b > c \geq d$ . For any Right option  $\mathbf{d}^R$  obtained from  $\mathbf{d}$  toppling rightward, we have  $\mathbf{bRLaLRd}^R > \{c|d\}$ .*

**Proof.** We prove that Left has a winning strategy in  $\mathbf{bRLaLRd}^R - \{c|d\}$  whoever plays first. When Left starts, she can move to  $\mathbf{bRLa} - \{c|d\}$ , which is positive. Now consider the case when Right starts, and his possible moves from  $\mathbf{bRLaLRd}^R - \{c|d\}$ . If Right plays in  $-\{c|d\}$ , we get

- $\mathbf{bRLaLRd}^R - c$ . Then Left can answer to  $\mathbf{bRLa} - c$ , which is positive.

Consider now Right's possible moves in  $\mathbf{bRLaLRd}^R$ . Toppling rightward, Right can move to:

- $\mathbf{b}^R - \{c|d\}$ , positive.
- $\mathbf{b} - \{c|d\}$ , positive.
- $\mathbf{bRLa}^R - \{c|d\}$ . Then Left can answer to  $\mathbf{a}^R - \{c|d\}$ , which is positive.
- $\mathbf{bRLaL} - \{c|d\}$ . Then Left can answer to  $\mathbf{aL} - \{c|d\}$ , which is positive.
- $\mathbf{bRLaLR}(\mathbf{d}^R)^R - \{c|d\}$ . Then Left can answer to  $\mathbf{bRLa} - \{c|d\}$ , which is positive.

Toppling leftward, Right can move to:

- $\mathbf{b}^R\mathbf{RLaLRd}^R - \{c|d\}$ . Then Left can answer to  $\mathbf{b}^R\mathbf{RLa} - \{c|d\}$ , which is positive.
- $\mathbf{LaLRd}^R - \{c|d\}$ . Then Left can answer to  $\mathbf{La} - \{c|d\}$ , which is positive.
- $\mathbf{a}^R\mathbf{LRd}^R - \{c|d\}$ . Then Left can answer to  $\mathbf{a}^R - \{c|d\}$ , which is positive.
- $\mathbf{d}^R - \{c|d\}$ . Then Left can answer to  $\mathbf{d}^R - d$ , which is positive.
- $(\mathbf{d}^R)^R - \{c|d\}$ . Then Left can answer to  $(\mathbf{d}^R)^R - d$ , which is positive.

□

**Lemma B.11** *Let  $a, b, c, d$  be numbers such that  $a \geq b > c \geq d$ . For any Right option  $\mathbf{c}^R$  obtained from  $\mathbf{c}$  toppling rightward, we have  $\mathbf{bRLaLRdRLc}^R > \{c|d\}$ .*

**Proof.** We prove that Left has a winning strategy in  $\mathbf{bRLaLRdRLc}^R - \{c|d\}$  whoever plays first. When Left starts, she can move to  $\mathbf{bRLa} - \{c|d\}$ , which is positive. Now consider the case when Right starts, and his possible moves from  $\mathbf{bRLaLRdRLc}^R - \{c|d\}$ . If Right plays in  $-\{c|d\}$ , we get

- $\mathbf{bRLaLRdRLc}^R - c$ . Then Left can answer to  $\mathbf{bRLa} - c$ , which is positive.

Consider now Right's possible moves in  $\mathbf{bRLaLRdRLc}^R$ . Toppling rightward, Right can move to:

- $\mathbf{b}^R - \{c|d\}$ , positive.
- $\mathbf{b} - \{c|d\}$ , positive.
- $\mathbf{bRLa}^R - \{c|d\}$ , positive.
- $\mathbf{bRLaL} - \{c|d\}$ , positive.
- $\mathbf{bRLaLRd}^R - \{c|d\}$ . Then Left can answer to  $\mathbf{bRLa} - \{c|d\}$ , which is positive.
- $\mathbf{bRLaLRd} - \{c|d\}$ , positive.
- $\mathbf{bRLaLRdRL}(\mathbf{c}^R)^R - \{c|d\}$ . Then Left can answer to  $\mathbf{bRLa} - \{c|d\}$ , which is positive.

Toppling leftward, Right can move to:

- $\mathbf{b}^R\mathbf{RLaLRdRLc}^R - \{c|d\}$ . Then Left can answer to  $\mathbf{b}^R\mathbf{RLa} - \{c|d\}$ , which is positive as  $\mathbf{b}^R\mathbf{RLa} > \{a|b\}$ .
- $\mathbf{LaLRdRLc}^R - \{c|d\}$ . Then Left can answer to  $\mathbf{La} - \{c|d\}$ , which is positive.
- $\mathbf{a}^R\mathbf{LRdRLc}^R - \{c|d\}$ . Then Left can answer to  $\mathbf{a}^R - \{c|d\}$ , which is positive.
- $\mathbf{dRLc}^R - \{c|d\}$ , positive by Lemma 3.39.
- $\mathbf{d}^R\mathbf{RLc}^R - \{c|d\}$ . Then Left can answer to  $\mathbf{c}^R - \{c|d\}$ , which is positive by Corollary 3.34.
- $\mathbf{Lc}^R - \{c|d\}$ , positive by Corollary 3.34.
- $(\mathbf{c}^R)^R - \{c|d\}$ , positive by Corollary 3.34.

□

We can now prove the following claim.

**Claim B.12** *Let  $a, b, c, d$  be numbers such that  $a \geq b > c \geq d$ . We have  $\mathbf{bRLaLRdRLc} = \{\{a|b\}|\{c|d\}\}$ .*

**Proof.** To prove that  $\mathbf{bRLaLRdRLc} = \{\{a|b\}|\{c|d\}\}$ , we prove that the second player has a winning strategy in  $\mathbf{bRLaLRdRLc} - \{\{a|b\}|\{c|d\}\}$ .

Without loss of generality, we may assume Right starts the game, and consider his possible moves from  $\mathbf{bRLaLRdRLc} - \{\{a|b\}|\{c|d\}\}$ . If Right plays in  $-\{\{a|b\}|\{c|d\}\}$ , we get

- $\mathbf{bRLaLRdRLc} - \{a|b\}$ . Then Left can answer to  $\mathbf{bRLa} - \{a|b\} = 0$ .

Consider now Right's possible moves in  $\mathbf{bRLaLRdRLc}$ . Toppling rightward, Right can move to:

- $\mathbf{b}^R - \{\{a|b\}|\{c|d\}\}$ . Then Left can answer to  $\mathbf{b}^R - \{c|d\}$ , which is positive.
- $\mathbf{b} - \{\{a|b\}|\{c|d\}\}$ . Then Left can answer to  $\mathbf{b} - \{c|d\}$ , which is positive.
- $\mathbf{bRLa}^R - \{\{a|b\}|\{c|d\}\}$ . Then Left can answer to  $\mathbf{a}^R - \{\{a|b\}|\{c|d\}\}$ , which is positive.
- $\mathbf{bRLaL} - \{\{a|b\}|\{c|d\}\}$ . Then Left can answer to  $\mathbf{aL} - \{\{a|b\}|\{c|d\}\}$ , which is positive.
- $\mathbf{bRLaLRd}^R - \{\{a|b\}|\{c|d\}\}$ . Then Left can answer to  $\mathbf{bRLaLRd}^R - \{c|d\}$ , which is positive by Lemma B.10.
- $\mathbf{bRLaLRd} - \{\{a|b\}|\{c|d\}\}$ . Then Left can answer to  $\mathbf{bRLaLRd} - \{c|d\}$ , which is positive.
- $\mathbf{bRLaLRdRLc}^R - \{\{a|b\}|\{c|d\}\}$ . Then Left can answer to  $\mathbf{bRLaLRdRLc}^R - \{c|d\}$ , which is positive by Lemma B.11.

Toppling leftward, Right can move to:

- $\mathbf{b}^R\mathbf{RLaLRdRLc} - \{\{a|b\}|\{c|d\}\}$ . Then Left can answer to  $\mathbf{b}^R\mathbf{RLa} - \{\{a|b\}|\{c|d\}\}$ , which is positive by Lemma B.9.
- $\mathbf{LaLRdRLc} - \{\{a|b\}|\{c|d\}\}$ . Then Left can answer to  $\mathbf{La} - \{\{a|b\}|\{c|d\}\}$ , which is positive.
- $\mathbf{a}^R\mathbf{LRdRLc} - \{\{a|b\}|\{c|d\}\}$ . Then Left can answer to  $\mathbf{a}^R - \{\{a|b\}|\{c|d\}\}$ , which is positive.
- $\mathbf{dRLc} - \{\{a|b\}|\{c|d\}\}$ . Then Left can answer to  $\mathbf{dRLc} - \{c|d\}$  which has value 0.
- $\mathbf{d}^R\mathbf{RLc} - \{\{a|b\}|\{c|d\}\}$ . Then Left can answer to  $\mathbf{d}^R\mathbf{RLc} - \{c|d\}$ , which is positive by Lemma 3.40.
- $\mathbf{Lc} - \{\{a|b\}|\{c|d\}\}$ . Then Left can answer to  $\mathbf{Lc} - \{c|d\}$ , which is positive by Corollary 3.34.
- $\mathbf{c}^R - \{\{a|b\}|\{c|d\}\}$ . Then Left can answer to  $\mathbf{c}^R - \{c|d\}$ , which is positive by Corollary 3.34.

□

As an example, here is a representation of  $\{\{1|1\}|\{\frac{1}{2}|0\}\}$ :



We now prove  $\mathbf{bRLaEdRLc}$  has value  $\{\{a|b\}|\{c|d\}\}$ . Again, we first prove some preliminary lemmas on options of  $\mathbf{bRLaEdRLc}$ .

**Lemma B.13** *Let  $a, b, c, d$  be numbers such that  $a \geq b > c \geq d$ . For any Right option  $\mathbf{d}^R$  obtained from  $\mathbf{d}$  toppling rightward, we have  $\mathbf{bRLaEd}^R > \{c|d\}$ .*

**Proof.** We prove Left has a winning strategy in  $\mathbf{bRLaEd}^R - \{c|d\}$  whoever plays first. When Left starts, she can move to  $\mathbf{bRLa} - \{c|d\}$ , which is positive. Now consider the case when Right starts, and his possible moves from  $\mathbf{bRLaEd}^R - \{c|d\}$ . If Right plays in  $-\{c|d\}$ , we get

- $\mathbf{bRLaEd}^R - c$ . Then Left can answer to  $\mathbf{bRLa} - c$ , which is positive.

Consider now Right's possible moves in  $\mathbf{bRLaEd}^R$ . Toppling rightward, Right can move to:

- $\mathbf{b}^R - \{c|d\}$ , positive.
- $\mathbf{b} - \{c|d\}$ , positive.
- $\mathbf{bRLa}^R - \{c|d\}$ , positive as  $\mathbf{bRLa}^R > \{a|b\} > \{c|d\}$ .
- $\mathbf{bRLa} - \{c|d\}$ , positive.
- $\mathbf{bRLaE}(\mathbf{d}^R)^R - \{c|d\}$ . Then Left can answer to  $\mathbf{bRLa} - \{c|d\}$ , which is positive.

Toppling leftward, Right can move to:

- $\mathbf{b}^R\mathbf{RLaEd}^R - \{c|d\}$ . Then Left can answer to  $\mathbf{b}^R\mathbf{RLa} - \{c|d\}$ , which is positive.
- $\mathbf{LaEd}^R - \{c|d\}$ . Then Left can answer to  $\mathbf{La} - \{c|d\}$ , which is positive.
- $\mathbf{a}^R\mathbf{Ed}^R - \{c|d\}$ . Then Left can answer to  $\mathbf{a}^R - \{c|d\}$ , which is positive.
- $\mathbf{d}^R - \{c|d\}$ . Then Left can answer to  $\mathbf{d}^R - d$ , which is positive.
- $(\mathbf{d}^R)^R - \{c|d\}$ . Then Left can answer to  $(\mathbf{d}^R)^R - d$ , which is positive.  $\square$

**Lemma B.14** *Let  $a, b, c, d$  be numbers such that  $a \geq b > c \geq d$ . For any Right option  $\mathbf{c}^R$  obtained from  $\mathbf{c}$  toppling rightward, we have  $\mathbf{bRLaEdRLc}^R > \{c|d\}$ .*

**Proof.** We prove Left has a winning strategy in  $\mathbf{bRLaEdRLc}^R - \{c|d\}$  whoever plays first. When Left starts, she can move to  $\mathbf{bRLa} - \{c|d\}$ , which is positive. Now consider the case when Right starts, and his possible moves from  $\mathbf{bRLaEdRLc}^R - \{c|d\}$ . If Right plays in  $-\{c|d\}$ , we get

- $\mathbf{bRLaEdRLc}^R - c$ . Then Left can answer to  $\mathbf{bRLa} - c$ , which is positive.

Consider now Right's possible moves in  $\mathbf{bRLaEdRLc}^R$ . Toppling rightward, Right can move to:

- $\mathbf{b}^R - \{c|d\}$ , positive.
- $\mathbf{b} - \{c|d\}$ , positive.
- $\mathbf{bRLa}^R - \{c|d\}$ , positive as  $\mathbf{bRLa}^R > \{a|b\} > \{c|d\}$ .
- $\mathbf{bRLa} - \{c|d\}$ , positive.
- $\mathbf{bRLaEd}^R - \{c|d\}$ . Then Left can answer to  $\mathbf{bRLa} - \{c|d\}$ , which is positive.

- $\mathbf{bRLaEd} - \{c|d\}$ , positive.
- $\mathbf{bRLaEdRL}(\mathbf{c}^R)^R - \{c|d\}$ . Then Left can answer to  $\mathbf{c}^R - \{c|d\}$ , which is positive by Corollary 3.34.

Toppling leftward, Right can move to:

- $\mathbf{b}^R\mathbf{RLaEdRLc}^R - \{c|d\}$ . Then Left can answer to  $\mathbf{b}^R\mathbf{RLa} - \{c|d\}$ , which is positive.
- $\mathbf{LaEdRLc}^R - \{c|d\}$ , positive by Lemma B.6.
- $\mathbf{a}^R\mathbf{EdRLc}^R - \{c|d\}$ . Then Left can answer to  $\mathbf{a}^R - \{c|d\}$ , which is positive.
- $\mathbf{dRLc}^R - \{c|d\}$ , positive by Lemma 3.39.
- $\mathbf{d}^R\mathbf{RLc}^R - \{c|d\}$ . Then Left can answer to  $\mathbf{c}^R - \{c|d\}$ , which is positive by Corollary 3.34.
- $\mathbf{Lc}^R - \{c|d\}$ , positive by Corollary 3.34.
- $(\mathbf{c}^R)^R - \{c|d\}$ , positive by Corollary 3.34.

□

We can now prove the following claim.

**Claim B.15** *Let  $a, b, c, d$  be numbers such that  $a \geq b > c \geq d$ . We have  $\mathbf{bRLaEdRLc} = \{\{a|b\}|\{c|d\}\}$ .*

**Proof.** To prove that  $\mathbf{bRLaEdRLc} = \{\{a|b\}|\{c|d\}\}$ , we prove that the second player has a winning strategy in  $\mathbf{bRLaEdRLc} - \{\{a|b\}|\{c|d\}\}$ . Without loss of generality, we may assume Right starts the game, and consider his possible moves from  $\mathbf{bRLaEdRLc} - \{\{a|b\}|\{c|d\}\}$ . If Right plays in  $-\{\{a|b\}|\{c|d\}\}$ , we get

- $\mathbf{bRLaEdRLc} - \{a|b\}$ . Then Left can answer to  $\mathbf{bRLa} - \{a|b\}$  which has value 0.

Consider now Right's possible move in  $\mathbf{bRLaEdRLc}$ . Toppling rightward, Right can move to:

- $\mathbf{b}^R - \{\{a|b\}|\{c|d\}\}$ . Then Left can answer to  $\mathbf{b}^R - \{c|d\}$ , which is positive.
- $\mathbf{b} - \{\{a|b\}|\{c|d\}\}$ . Then Left can answer to  $\mathbf{b} - \{c|d\}$ , which is positive.
- $\mathbf{bRLa}^R - \{\{a|b\}|\{c|d\}\}$ . Then Left can answer to  $\mathbf{a}^R - \{\{a|b\}|\{c|d\}\}$ , which is positive.
- $\mathbf{bRLa} - \{\{a|b\}|\{c|d\}\}$ . Then Left can answer to  $\mathbf{bRLa} - \{c|d\}$ , which is positive.
- $\mathbf{bRLaEd}^R - \{\{a|b\}|\{c|d\}\}$ . Then Left can answer to  $\mathbf{bRLaEd}^R - \{c|d\}$ , which is positive by Lemma B.13.
- $\mathbf{bRLaEd} - \{\{a|b\}|\{c|d\}\}$ . Then Left can answer to  $\mathbf{bRLaEd} - \{c|d\}$ , which is positive.
- $\mathbf{bRLaEdRLc}^R - \{\{a|b\}|\{c|d\}\}$ . Then Left can answer to  $\mathbf{bRLaEdRLc}^R - \{c|d\}$ , which is positive by Lemma B.14.

Toppling leftward, Right can move to:



- $\mathbf{b}^R\mathbf{RLaEdRLc} - \{\{a|b\}|\{c|d\}\}$ . Then Left can answer to  $\mathbf{b}^R\mathbf{RLa} - \{\{a|b\}|\{c|d\}\}$ , which is positive by Lemma B.9.
- $\mathbf{LaEdRLc} - \{\{a|b\}|\{c|d\}\}$ . Then Left can answer to  $\mathbf{La} - \{\{a|b\}|\{c|d\}\}$ , which is positive.
- $\mathbf{a}^R\mathbf{EdRLc} - \{\{a|b\}|\{c|d\}\}$ . Then Left can answer to  $\mathbf{a}^R - \{\{a|b\}|\{c|d\}\}$ , which is positive.
- $\mathbf{dRLc} - \{\{a|b\}|\{c|d\}\}$ . Then Left can answer to  $\mathbf{dRLc} - \{c|d\}$  which has value 0.
- $\mathbf{d}^R\mathbf{RLc} - \{\{a|b\}|\{c|d\}\}$ . Then Left can answer to  $\mathbf{d}^R\mathbf{RLc} - \{c|d\}$ , which is positive by Lemma 3.40.
- $\mathbf{Lc} - \{\{a|b\}|\{c|d\}\}$ . Then Left can answer to  $\mathbf{Lc} - \{c|d\}$ , which is positive by Corollary 3.34.
- $\mathbf{c}^R - \{\{a|b\}|\{c|d\}\}$ . Then Left can answer to  $\mathbf{c}^R - \{c|d\}$ , which is positive by Corollary 3.34.

□

As an example, here is a representation of  $\{\{\frac{5}{2}|1\}|\{-\frac{1}{4}|-\frac{1}{2}\}\}$ :




---

### B.3 Proof of Lemma 3.80

---

#### Lemma 3.80

1.  $\forall n \geq 1, x^{2n}B \equiv^+ \frac{3}{4}$  and  $x^{2n-1}B \equiv^+ \frac{1}{2}$ .
2.  $\forall n \geq 0, Bx^{2n}B \equiv^+ 1$  and  $Bx^{2n+1}B \equiv^+ \frac{3}{2}$ .
3.  $\forall n \geq 0, Bx^{2n}W \equiv^+ 0$  and  $Bx^{2n+1}W \equiv^+ *$ .
4.  $\forall n \geq 0, m \geq 0, x^{2n}Bx^{2m}B \geq^+ 1, x^{2n+1}Bx^{2m+1}B \geq^+ 1,$   
 $x^{2n+1}Bx^{2m}B >^+ \frac{3}{4}$  and  $x^{2n}Bx^{2m+1}B >^+ \frac{3}{4}$ .
5.  $\forall n \geq 0, m \geq 0, x^{2n}Bx^{2m}W \geq^+ -\frac{1}{4}, x^{2n+1}Bx^{2m+1}W \geq^+ -\frac{1}{4},$   
 $x^{2n+1}Bx^{2m}W \geq^+ -\frac{1}{2}$  and  $x^{2n}Bx^{2m+1}W \geq^+ -\frac{1}{2}$ .
6.  $\forall n \geq 0, m \geq 0, Bx^{2n}Bx^{2m}B >^+ \frac{3}{2}, Bx^{2n+1}Bx^{2m+1}B >^+ \frac{3}{2},$   
 $Bx^{2n+1}Bx^{2m}B \geq^+ \frac{3}{2}$  and  $Bx^{2n}Bx^{2m+1}B \geq^+ \frac{3}{2}$ .
7.  $\forall n \geq 0, m \geq 0, Bx^{2n}Bx^{2m}W \geq^+ 0, Bx^{2n+1}Bx^{2m+1}W \geq^+ 0,$   
 $Bx^{2n+1}Bx^{2m}W \geq^+ \frac{1}{2}$  and  $Bx^{2n}Bx^{2m+1}W \geq^+ \frac{1}{2}$ .

**Proof.** We show the results by induction on the number of vertices of the graph.

We start with 1. First consider Left plays first, and all her possible moves from  $x^{2n}B$ . She can move to:

- $x^{2n-1}WB$ , which has value  $x^{2n-1}W + B$ , having value  $\frac{1}{2}$  by induction.
- $W + oWx^{2n-2}B$ , having value at most  $W + x^{2n-1}B$  which is negative by induction.
- $x^iWo + W + oWx^{2n-i-3}B$ , having value at most  $x^{i+1} + W + x^{2n-i-2}B$  which is negative by induction.
- $x^{2n-2}Wo + W$ , having value at most  $x^{2n-1} + W$  which is negative by induction.
- $x^iWx^{2n-i-1}B$ , which has value at most  $\frac{1}{2}$  by induction.
- $x^{2n-1}Wo$ , which has value at most  $x^{2n}$ , having value 0.

Now consider Right plays first, and all his possible moves from  $x^{2n}B$ . He can move to:

- $x^{2n-1}BB$ , which has value  $x^{2n-1} + B$  having value 1 or  $1*$ .
- $B + oBx^{2n-2}B$ , having value at least  $B + x^{2n-1}B$  which has value  $\frac{3}{2}$ .
- $x^iBo + B + oBx^{2n-i-3}B$ , having value at least  $x^{i+1} + B + x^{2n-i-2}B$  which has value more than 1.
- $x^{2n-2}Bo + B + B$ , having value at least  $x^{2n-1} + B + B$  which has value 2 or  $2*$ .
- $x^iBx^{2n-i-1}B$ , which has value more than  $\frac{3}{4}$  by induction.

Now consider Left plays first, and all her possible moves from  $x^{2n-1}B$ .

She can move to:

- $x^{2n-2}WB$ , which has value  $\frac{1}{4}$  by induction.
- $W + oWx^{2n-3}B$ , having value at most  $W + x^{2n-2}B$  which is negative.
- $x^iWo + W + oWx^{2n-i-4}B$ , having value at most  $x^{i+1} + W + x^{2n-i-3}B$  which is negative.
- $x^{2n-3}Wo + W$ , having value at most  $x^{2n-2} + W$  which is negative.
- $x^iWx^{2n-i-2}B$ , which has value at most  $\frac{1}{4}$  by induction.
- $x^{2n-2}Wo$ , which has value at most  $x^{2n-1}$ , having value 0 or  $*$ .

Now consider Right plays first, and all his possible moves from  $x^{2n-1}B$ . He can move to:

- $x^{2n-2}BB$ , which has value 1.
- $B + oBx^{2n-3}B$ , having value at least  $B + x^{2n-2}B$  which has value  $\frac{7}{4}$ .
- $x^iBo + B + oBx^{2n-i-4}B$ , having value at least  $x^{i+1} + B + x^{2n-i-3}B$  which has value more than 1.
- $x^{2n-3}Bo + B + B$ , having value at least  $x^{2n-2} + B + B$  which has value 2.
- $x^iBx^{2n-i-2}B$ , which has value at least 1 by induction.

We now prove 2. As  $BB \equiv^+ 1$  and  $BxB \equiv^+ \frac{3}{2}$  has been established earlier, we can consider  $n \geq 1$ .

First consider Left plays first, and all her possible moves from  $Bx^{2n}B$ .

She can move to:

- $oWx^{2n-1}B$ , having value at most  $x^{2n}B$  which has value  $\frac{3}{4}$ .
- $Bx^iWo + W + oWx^{2n-i-3}B$ , which has value at most  $Bx^{i+1} + W + x^{2n-i-2}B$ , having value at most  $\frac{1}{4}$ .

- $BWx^{2n-1}B$  which has value  $1*$ .
- $Bx^iWx^{2n-i-1}B$ . Without loss of generality, we may assume  $i$  is odd. Then Right can answer to  $Bx^{i-1}BWx^{2n-i-1}B$ , having value 1, and proving that  $Bx^iWx^{2n-i-1}B$  has a value that is not 1 or more.

Now consider Right plays first, and all his possible moves from  $Bx^{2n}B$ . He can move to:

- $B + B + oBx^{2n-2}B$ , which has value at least  $B + B + x^{2n-1}B$ , having value  $\frac{5}{2}$ .
- $Bx^iBo + B + oBx^{2n-i-3}B$ , which has value at least  $Bx^{i+1} + B + x^{2n-i-2}B$ , having value at least  $\frac{9}{4}$ .
- $BBx^{2n-1}B$  which has value  $\frac{3}{2}$ .
- $Bx^iBx^{2n-1}B$  which has value at least  $\frac{3}{2}$ .

Now consider Left plays first, and all her possible moves from  $Bx^{2n+1}B$ . She can move to:

- $oWx^{2n}B$ , having value at most  $x^{2n+1}B$  which has value  $\frac{1}{2}$ .
- $W + oWx^{2n-1}B$ , which has value at most  $W + x^{2n}B$  having value  $-\frac{1}{4}$ .
- $Bx^iWo + W + oWx^{2n-i-2}B$ , which has value at most  $Bx^{i+1} + W + x^{2n-i-1}B$ , having value at most  $\frac{1}{2}$ .
- $BWx^{2n}B$  which has value 1.
- $Bx^iWx^{2n-i}B$ . Then Right can answer to  $Bx^{i-1}BWx^{2n-i}B$ , having value  $1*$  or  $\frac{3}{2}$ , and proving that  $Bx^iWx^{2n-i}B$  has a value that is not  $\frac{3}{2}$  or more.

Now consider Right plays first, and all his possible moves from  $Bx^{2n+1}B$ . He can move to:

- $B + B + oBx^{2n-1}B$ , which has value at least  $B + B + x^{2n}B$ , having value  $\frac{11}{4}$ .
- $Bx^iBo + B + oBx^{2n-i-2}B$ , which has value at least  $Bx^{i+1} + B + x^{2n-i-1}B$ , having value at least 2.
- $BBx^{2n}B$  which has value  $\frac{7}{4}$ .
- $Bx^iBx^{2n-i}B$  which has value more than  $\frac{3}{2}$ .

We now prove 3.  $Bx^{2n}W \equiv^+ 0$  follows from Theorem 3.51. From  $Bx^{2n+1}W$ , Left can move to  $BWx^{2n}W$  having value 0, and Right can move to  $Bx^{2n}BW$  having value 0.

We now prove 4. If  $m = 0$ ,  $x^{2n}Bx^{2m}B$  has value 1 and  $x^{2n+1}Bx^{2m}B$  has value 1 or  $1*$ , hence for these two cases, we may consider  $m \geq 1$ . If  $n = 0$ ,  $x^{2n}Bx^{2m}B$  has value 1 and  $x^{2n}Bx^{2m+1}B$  has value  $\frac{3}{2}$ , hence for these two cases, we may consider  $n \geq 1$ . Consider Right plays first, and his possible moves from  $x^{2n}Bx^{2m}B - 1$ . He can move to:

- $x^{2n}Bx^{2m}B$ . Then Left can answer to  $x^{2n}BWx^{2m-1}B$ , which has value  $\frac{3}{4}$ .
- $B + Bx^{2n-2}Bx^{2m}B - 1$ , having value more than  $\frac{3}{2}$ .
- $x^iBo + B + oBx^{2n-i-3}Bx^{2m}B - 1$ , which has value at least  $x^{i+1} + B + x^{2n-i-2}Bx^{2m}B - 1$  having value more than  $\frac{3}{4}$ .

- $x^{2n-2}Bo + B + Bx^{2m}B - 1$ , which has value at least  $x^{2n-1} + B + Bx^{2m}B - 1$ , having value 1 or  $1^*$ .
- $x^{2n}B + B + oBx^{2m-2}B - 1$ , which has value at least  $x^{2n}B + B + x^{2m-1}B - 1$ , having value  $\frac{5}{4}$ .
- $x^{2n}Bx^iBo + B + oBx^{2m-i-3}B - 1$ , which has value at least  $x^{2n}ox^{i+1} + B + x^{2m-i-2}B - 1$ , having value at least  $\frac{1}{2}$  or  $\frac{1}{2}^*$ .
- $x^{2n}Bx^{2m-2}Bo + B + B - 1$ , which has value at least  $x^{2n}ox^{2m-1} + B + B - 1$ , having value 1 or  $1^*$ .
- $Bx^{2n-1}Bx^{2m}B - 1$ , having value at least  $\frac{1}{2}$ .
- $x^iBx^{2n-i-1}Bx^{2m}B - 1$ . Then Left can answer to  $x^iBWx^{2n-i-2}Bx^{2m}B - 1$ , having value at least 0 when  $i$  is odd, or to  $x^{i-1}WBx^{2n-i-1}Bx^{2m}B - 1$ , having value at least 0 when  $i$  is even.
- $x^{2n-1}BBx^{2m}B - 1$ , having value at least  $x^{2n-1}B + x^{2m}B - 1$ , which has value  $\frac{1}{4}$ .
- $x^{2n}Bx^iBx^{2m-i-1}B - 1$ . Then Left can answer to  $x^{2n-1}WBx^iBx^{2m-i-1}B - 1$ , which has value at least 0.

Consider Right plays first, and his possible moves from  $x^{2n+1}Bx^{2m+1}B - 1$ . He can move to:

- $x^{2n+1}Bx^{2m+1}B$ . Then Left can answer to  $x^{2n+1}BWx^{2m}B$ , which has value  $\frac{1}{2}$ .
- $B + Bx^{2n-1}Bx^{2m+1}B - 1$ , having value more than  $\frac{3}{4}$ .
- $x^iBo + B + oBx^{2n-i-2}Bx^{2m+1}B - 1$ , which has value at least  $x^{i+1} + B + x^{2n-i-1}Bx^{2m+1}B - 1$  having value more than  $\frac{3}{4}$ .
- $x^{2n-1}Bo + B + Bx^{2m+1}B - 1$ , which has value at least  $x^{2n} + B + Bx^{2m+1}B - 1$ , having value  $\frac{3}{2}$ .
- $x^{2n+1}B + B + oBx^{2m-1}B - 1$ , which has value at least  $x^{2n+1}B + B + x^{2m}B - 1$ , having value  $\frac{5}{4}$ .
- $x^{2n+1}Bx^iBo + B + oBx^{2m-i-2}B - 1$ , which has value at least  $x^{2n+1}ox^{i+1} + B + x^{2m-i-1}B - 1$ , having value at least  $\frac{1}{2}$  or  $\frac{1}{2}^*$ .
- $x^{2n+1}Bx^{2m-1}Bo + B + B - 1$ , which has value at least  $x^{2n+1}ox^{2m} + B + B - 1$ , having value at least 1 or  $1^*$ .
- $Bx^{2n}Bx^{2m+1}B - 1$ , having value at least  $\frac{1}{2}$ .
- $x^iBx^{2n-i}Bx^{2m+1}B - 1$ . Then Left can answer to  $x^iBWx^{2n-i-1}Bx^{2m+1}B - 1$ , having value at least 0 when  $i$  is odd, or to  $x^{i-1}WBx^{2n-i}Bx^{2m+1}B - 1$ , having value at least 0 when  $i$  is even.
- $x^{2n}BBx^{2m+1}B - 1$ , having value at least  $x^{2n}B + x^{2m}B - 1$ , which has value  $\frac{1}{2}$ .
- $x^{2n+1}Bx^iBx^{2m-i}B - 1$ . Then Left can answer to  $x^{2n+1}BWx^{i-1}Bx^{2m-i}B - 1$ , which has value at least 0.

If Left plays first in  $x^{2n+1}Bx^{2m}B - \frac{3}{4}$ , she can move to  $x^{2n+1}Bx^{2m-1}WB - \frac{3}{4}$ , having value at least 0. Now consider Right plays first, and his possible moves

from  $x^{2n+1}Bx^{2m}B - \frac{3}{4}$ . He can move to:

- $x^{2n+1}Bx^{2m}B - \frac{1}{2}$ . Then Left can answer to  $x^{2n+1}Bx^{2m-1}WB - \frac{1}{2}$ , which has value at least  $\frac{1}{4}$ .
- $B + Bx^{2n-1}Bx^{2m}B - \frac{3}{4}$ , having value at least  $\frac{7}{4}$ .
- $x^iBo + B + oBx^{2n-i-2}Bx^{2m}B - \frac{3}{4}$ , which has value at least  $x^{i+1} + B + x^{2n-i-1}Bx^{2m}B - \frac{3}{4}$  having value more than 1.
- $x^{2n-1}Bo + B + Bx^{2m}B - \frac{3}{4}$ , which has value at least  $x^{2n} + B + Bx^{2m}B - \frac{3}{4}$ , having value  $\frac{5}{4}$ .
- $x^{2n+1}B + B + oBx^{2m-2}B - \frac{3}{4}$ , which has value at least  $x^{2n+1}B + B + x^{2m-1}B - \frac{3}{4}$ , having value  $\frac{5}{4}$ .
- $x^{2n+1}Bx^iBo + B + oBx^{2m-i-3}B - \frac{3}{4}$ , which has value at least  $x^{2n+1}ox^{i+1} + B + x^{2m-i-2}B - \frac{3}{4}$ , having value at least  $\frac{3}{4}$  or  $\frac{3}{4}$ \*
- $x^{2n+1}Bx^{2m-2}Bo + B + B - \frac{3}{4}$ , which has value at least  $x^{2n+1}ox^{2m-1} + B + B - \frac{3}{4}$ , having value  $\frac{5}{4}$  or  $\frac{5}{4}$ \*
- $Bx^{2n}Bx^{2m}B - \frac{3}{4}$ , having value more than  $\frac{3}{4}$ .
- $x^iBx^{2n-i}Bx^{2m}B - \frac{3}{4}$ . Then Left can answer to  $x^{i-1}WBx^{2n-i}Bx^{2m}B - \frac{3}{4}$ , having value at least 0.
- $x^{2n+1}Bx^iBx^{2m-i-1}B - \frac{3}{4}$ . Then Left can answer to  $x^{2n}WBx^iBx^{2m-i-1}B - \frac{3}{4}$ , which has value at least 0.

If Left plays first in  $x^{2n}Bx^{2m+1}B - \frac{3}{4}$ , she can move to  $x^{2n}BWx^{2m}B - \frac{3}{4}$ , having value 0. Now consider Right plays first, and his possible moves from  $x^{2n}Bx^{2m+1}B - \frac{3}{4}$ . He can move to:

- $x^{2n}Bx^{2m+1}B - \frac{1}{2}$ . Then Left can answer to  $x^{2n}BWx^{2m}B - \frac{1}{2}$ , which has value  $\frac{1}{4}$ .
- $B + Bx^{2n-2}Bx^{2m+1}B - \frac{3}{4}$ , having value at least  $\frac{7}{4}$ .
- $x^iBo + B + oBx^{2n-i-3}Bx^{2m+1}B - \frac{3}{4}$ , which has value at least  $x^{i+1} + B + x^{2n-i-2}Bx^{2m+1}B - \frac{3}{4}$ , having value more than 1.
- $x^{2n-2}Bo + B + Bx^{2m+1}B - \frac{3}{4}$ , which has value at least  $x^{2n-1} + B + Bx^{2m+1}B - \frac{3}{4}$ , having value at least  $\frac{7}{4}$  or  $\frac{7}{4}$ \*
- $x^{2n}B + B + oBx^{2m-1}B - \frac{3}{4}$ , which has value at least  $x^{2n}B + B + x^{2m}B - \frac{3}{4}$ , having value  $\frac{7}{4}$ .
- $x^{2n}Bx^iBo + B + oBx^{2m-i-2}B - \frac{3}{4}$ , which has value at least  $x^{2n}ox^{i+1} + B + x^{2m-i-1}B - \frac{3}{4}$ , having value at least  $\frac{3}{4}$  or  $\frac{3}{4}$ \*
- $x^{2n}Bx^{2m-1}Bo + B + B - \frac{3}{4}$ , which has value at least  $x^{2n}ox^{2m} + B + B - \frac{3}{4}$ , having value  $\frac{5}{4}$  or  $\frac{5}{4}$ \*
- $Bx^{2n-1}Bx^{2m+1}B - \frac{3}{4}$ , having value more than  $\frac{3}{4}$ .
- $x^iBx^{2n-i-1}Bx^{2m+1}B - \frac{3}{4}$ . Then Left can answer to  $x^{i-1}WBx^{2n-i-1}Bx^{2m+1}B - \frac{3}{4}$ , which has value at least 0.
- $x^{2n}Bx^iBx^{2m-i}B - \frac{3}{4}$ . Then Left can answer to  $x^{2n-1}WBx^iBx^{2m-i}B - \frac{3}{4}$ , which has value more than  $\frac{1}{4}$ .

We now prove 5. If  $n = 0$ ,  $x^{2n}Bx^{2m}W$  has value 0 and  $x^{2n}Bx^{2m+1}W$  has value \*, hence for these two cases, we may consider  $n \geq 1$ . If  $m = 0$ ,  $x^{2n}Bx^{2m}W$  has value  $-\frac{1}{4}$  and  $x^{2n+1}Bx^{2m}W$  has value  $-\frac{1}{2}$ , hence for these

two cases, we may consider  $m \geq 1$ . Consider Right plays first and his possible moves from  $x^{2n}Bx^{2m}W + \frac{1}{4}$ . He can move to:

- $x^{2n}Bx^{2m}W + \frac{1}{2}$ . Then Left can answer to  $x^{2n-1}WBx^{2m}W + \frac{1}{2}$ , which has value 0.
- $B + oBx^{2n-2}Bx^{2m}W + \frac{1}{4}$ , which has value at least  $B + x^{2n-1}Bx^{2m}W + \frac{1}{4}$ , having value at least 1.
- $x^iBo + B + oBx^{2n-i-3}Bx^{2m}W + \frac{1}{4}$ , which has value at least  $x^{i+1} + B + x^{2n-i-2}Bx^{2m}W + \frac{1}{4}$ , having value at least  $\frac{3}{4}$  or  $\frac{3}{4}^*$ .
- $x^{2n-2}Bo + B + Bx^{2m}W + \frac{1}{4}$ , which has value at least  $x^{2n-1} + B + Bx^{2m}W + \frac{1}{4}$ , having value  $\frac{5}{4}$  or  $\frac{5}{4}^*$ .
- $x^{2n}B + B + oBx^{2m-2}W + \frac{1}{4}$ , which has value at least  $x^{2n}B + B + x^{2m-1}W + \frac{1}{4}$ , having value  $\frac{3}{2}$ .
- $x^{2n}Bx^iBo + B + oBx^{2m-i-3}W + \frac{1}{4}$ , which has value at least  $x^{2n}ox^{i+1} + B + x^{2m-i-2}W + \frac{1}{4}$ , having value  $\frac{1}{2}$  or  $\frac{1}{2}^*$ .
- $x^{2n}Bx^{2m-2}Bo + B + \frac{1}{4}$ , which has value at least  $x^{2n}ox^{2m-1} + B + \frac{1}{4}$ , having value  $\frac{5}{4}$  or  $\frac{5}{4}^*$ .
- $x^{2n}Bx^{2m-1}Bo + \frac{1}{4}$ , which has value at least  $x^{2n}ox^{2m} + \frac{1}{4}$ , having value  $\frac{1}{4}$  or  $\frac{1}{4}^*$ .
- $x^iBx^{2n-i-1}Bx^{2m}W + \frac{1}{4}$ . Then Left can answer to  $x^iBx^{2n-i-2}WBx^{2m}W + \frac{1}{4}$ , which has value at least 0.
- $x^{2n-1}BBx^{2m}W + \frac{1}{4}$ , having value at least  $x^{2n-1}B + x^{2m}W + \frac{1}{4}$ , which has value 0.
- $x^{2n}Bx^iBx^{2m-i-1}W + \frac{1}{4}$ . Then Left can answer to  $x^{2n-1}WBx^iBx^{2m-i-1}W + \frac{1}{4}$ , which has value at least  $\frac{1}{4}$ .

Consider Right plays first and his possible moves from  $x^{2n+1}Bx^{2m+1}W + \frac{1}{4}$ . He can move to:

- $x^{2n+1}Bx^{2m+1}W + \frac{1}{2}$ . Then Left can answer to  $x^{2n+1}BWx^{2m}W + \frac{1}{2}$ , which has value 0.
- $B + oBx^{2n-1}Bx^{2m+1}W + \frac{1}{4}$ , which has value at least  $B + x^{2n}Bx^{2m+1}W + \frac{1}{4}$ , having value at least 1.
- $x^iBo + B + oBx^{2n-i-2}Bx^{2m+1}W + \frac{1}{4}$ , which has value at least  $x^{i+1} + B + x^{2n-i-1}Bx^{2m+1}W + \frac{1}{4}$ , having value at least  $\frac{3}{4}$  or  $\frac{3}{4}^*$ .
- $x^{2n-1}Bo + B + Bx^{2m+1}W + \frac{1}{4}$ , which has value at least  $x^{2n} + B + Bx^{2m+1}W + \frac{1}{4}$ , having value  $\frac{5}{4}^*$ .
- $x^{2n+1}B + B + oBx^{2m-1}W + \frac{1}{4}$ , which has value at least  $x^{2n+1}B + B + x^{2m}W + \frac{1}{4}$ , having value 1.
- $x^{2n+1}Bx^iBo + B + oBx^{2m-i-2}W + \frac{1}{4}$ , which has value at least  $x^{2n+1}ox^{i+1} + B + x^{2m-i-1}W + \frac{1}{4}$ , having value at least  $\frac{1}{2}$  or  $\frac{1}{2}^*$ .
- $x^{2n+1}Bx^{2m-1}Bo + B + \frac{1}{4}$ , which has value at least  $x^{2n+1}ox^{2m} + B + \frac{1}{4}$ , having value  $\frac{5}{4}$  or  $\frac{5}{4}^*$ .
- $x^{2n+1}Bx^{2m}Bo + \frac{1}{4}$ , which has value at least  $x^{2n+1}ox^{2m+1} + \frac{1}{4}$ , having value  $\frac{1}{4}$  or  $\frac{1}{4}^*$ .
- $x^iBx^{2n-i}Bx^{2m+1}W + \frac{1}{4}$ . Then Left can answer to

- $x^i Bx^{2n-i} BWx^{2m}W + \frac{1}{4}$ , which has value at least  $\frac{1}{4}$ .
- $x^{2n+1} BBx^{2m}W + \frac{1}{4}$ , which has value at least  $x^{2n+1} + Bx^{2m}W + \frac{1}{4}$ , having value  $\frac{1}{4}$  or  $\frac{1}{4}$ \*
- $x^{2n+1} Bx^i Bx^{2m-i}W + \frac{1}{4}$ . Then Left can answer to  $x^{2n+1} Bx^{i-1} WBx^{2m-i}W + \frac{1}{4}$ , which has value at least 0 when  $i$  is even, or to  $x^{2n+1} Bx^i BWx^{2m-i-1}W + \frac{1}{4}$ , which has value at least  $\frac{1}{4}$  when  $i$  is odd.
- $x^{2n+1} Bx^{2m}BW + \frac{1}{4}$ , having value more than 0.

Consider Right plays first and his possible moves from  $x^{2n+1} Bx^{2m}W + \frac{1}{2}$ . He can move to:

- $x^{2n+1} Bx^{2m}W + 1$ . Then Left can answer to  $x^{2n} WBx^{2m}W + 1$ , which has value  $\frac{1}{4}$ .
- $B + oBx^{2n-1} Bx^{2m}W + \frac{1}{2}$ , which has value at least  $B + x^{2n} Bx^{2m}W + \frac{1}{2}$ , having value at least  $\frac{5}{4}$ .
- $x^i Bo + B + oBx^{2n-i-2} Bx^{2m}W + \frac{1}{2}$ , which has value at least  $x^{i+1} + B + x^{2n-i-1} Bx^{2m}W + \frac{1}{2}$ , having value at least 1 or  $1*$ .
- $x^{2n-1} Bo + B + Bx^{2m}W + \frac{1}{2}$ , which has value at least  $x^{2n} + B + Bx^{2m}W + \frac{1}{2}$ , having value  $\frac{3}{2}$ .
- $x^{2n+1} B + B + oBx^{2m-2}W + \frac{1}{2}$ , which has value at least  $x^{2n+1} B + B + x^{2m-1}W + \frac{1}{2}$ , having value  $\frac{3}{2}$ .
- $x^{2n+1} Bx^i Bo + B + oBx^{2m-i-3}W + \frac{1}{2}$ , which has value at least  $x^{2n+1} ox^{i+1} + B + x^{2m-i-2}W + \frac{1}{2}$ , having value at least  $\frac{3}{4}$  or  $\frac{3}{4}$ \*
- $x^{2n+1} Bx^{2m-2}Bo + B + \frac{1}{2}$ , which has value at least  $x^{2n+1} ox^{2m-1} + B + \frac{1}{2}$ , having value  $\frac{3}{2}$  or  $\frac{3}{2}$ \*
- $x^{2n+1} Bx^{2m-1}Bo + \frac{1}{2}$ , which has value at least  $x^{2n+1} ox^{2m} + \frac{1}{2}$ , having value  $\frac{1}{2}$  or  $\frac{1}{2}$ \*
- $x^i Bx^{2n-i} Bx^{2m}W + \frac{1}{2}$ . Then Left can answer to  $x^i Bx^{2n-i-1} WBx^{2m}W + \frac{1}{2}$ , which has value at least 0.
- $x^{2n} BBx^{2m}W + \frac{1}{2}$ , which has value at least  $x^{2n} B + x^{2m}W + \frac{1}{2}$ , having value  $\frac{1}{2}$ .
- $x^{2n+1} Bx^i Bx^{2m-i-1}W + \frac{1}{2}$ . Then Left can answer to  $x^{2n} WBx^i Bx^{2m-i-1}W + \frac{1}{2}$ , which has value at least  $\frac{1}{4}$ .

Consider Right plays first and his possible moves from  $x^{2n} Bx^{2m+1}W + \frac{1}{2}$ . He can move to:

- $x^{2n} Bx^{2m+1}W + 1$ . Then Left can answer to  $x^{2n-1} WBx^{2m+1}W + 1$ , which has value  $\frac{1}{2}$ \*
- $B + oBx^{2n-2} Bx^{2m+1}W + \frac{1}{2}$  which has value at least  $B + x^{2n-1} Bx^{2m+1}W + \frac{1}{2}$ , having value at least 1.
- $x^i Bo + B + oBx^{2n-i-3} Bx^{2m+1}W + \frac{1}{2}$ , which has value at least  $x^{i+1} + B + x^{2n-i-2} Bx^{2m+1}W + \frac{1}{2}$ , having value at least 1 or  $1*$ .
- $x^{2n-2} Bo + B + Bx^{2m+1}W + \frac{1}{2}$ , which has value at least  $x^{2n-1} + B + Bx^{2m+1}W + \frac{1}{2}$ , having value  $\frac{3}{2}$  or  $\frac{3}{2}$ \*
- $x^{2n} B + B + oBx^{2m-1}W + \frac{1}{2}$ , which has value at least

- $x^{2n}B + B + x^{2m}W + \frac{1}{2}$ , having value  $\frac{3}{2}$ .
- $x^{2n}Bx^iBo + B + oBx^{2m-i-2}W + \frac{1}{2}$ , which has value at least  $x^{2n}ox^{i+1} + B + x^{2m-i-1}W + \frac{1}{2}$ , having value at least  $\frac{3}{4}$  or  $\frac{3}{4}$ \*
- $x^{2n}Bx^{2m-1}Bo + B + \frac{1}{2}$ , which has value at least  $x^{2n}ox^{2m} + B + \frac{1}{2}$ , having value  $\frac{3}{2}$  or  $\frac{3}{2}$ \*
- $x^{2n}Bx^{2m-1}Bo + \frac{1}{2}$ , which has value at least  $x^{2n}ox^{2m} + \frac{1}{2}$ , having value  $\frac{1}{2}$  or  $\frac{1}{2}$ \*
- $x^iBx^{2n-i-1}Bx^{2m+1}W + \frac{1}{2}$ . Then Left can answer to  $x^iBx^{2n-i-2}WBx^{2m+1}W + \frac{1}{2}$ , which has value at least  $\frac{1}{4}$ \*
- $x^{2n-1}BBx^{2m+1}W + \frac{1}{2}$ , which has value at least  $x^{2n-1}B + x^{2m+1}W + \frac{1}{2}$ , having value  $\frac{1}{2}$ .
- $x^{2n}Bx^iBx^{2m-i}W + \frac{1}{2}$ . Then Left can answer to  $x^{2n-1}WBx^iBx^{2m-i}W + \frac{1}{2}$ , which has value at least 0.

We now prove 6. If  $n = 0$ ,  $Bx^{2n}Bx^{2m}B$  has value  $\frac{7}{4}$  and  $Bx^{2n}Bx^{2m+1}B$  has value  $\frac{3}{2}$ , hence for these two cases, we may consider  $n \geq 1$ . If  $m = 0$ ,  $Bx^{2n}Bx^{2m}B$  has value  $\frac{7}{4}$  and  $Bx^{2n+1}Bx^{2m}B$  has value  $\frac{3}{2}$ , hence for these two cases, we may consider  $m \geq 1$ . If Left plays first in  $Bx^{2n}Bx^{2m}B - \frac{3}{2}$ , she can move to  $BWx^{2n-1}Bx^{2m}B - \frac{3}{2}$  which has value at least 0. Now consider Right plays first, and his possible moves from  $Bx^{2n}Bx^{2m}B - \frac{3}{2}$ . He can move to:

- $Bx^{2n}Bx^{2m}B - 1$ . Then Left can answer to  $BWx^{2n-1}Bx^{2m}B - 1$  which has value at least  $\frac{1}{2}$ .
- $B + B + oBx^{2n-2}Bx^{2m}B - \frac{3}{2}$ , which has value at least  $B + B + x^{2n-1}Bx^{2m}B - \frac{3}{2}$ , having value more than  $\frac{5}{4}$ .
- $Bx^iBo + B + oBx^{2n-i-3}Bx^{2m}B - \frac{3}{2}$ , which has value at least  $Bx^{i+1} + B + x^{2n-i-2}Bx^{2m}B - \frac{3}{2}$ , having value more than  $\frac{3}{4}$ .
- $Bx^{2n-2}Bo + B + Bx^{2m}B - \frac{3}{2}$ , which has value at least  $Bx^{2n-1} + B + Bx^{2m}B - \frac{3}{2}$ , having value 1.
- $Bx^iBx^{2n-i-1}Bx^{2m}B - \frac{3}{2}$ , which has value at least  $Bx^iBx^{2n-i-1} + x^{2m}B - \frac{3}{2}$ , having value more than 0.

If Left plays first in  $Bx^{2n+1}Bx^{2m+1}B - \frac{3}{2}$ , she can move to  $BWx^{2n}Bx^{2m+1}B - \frac{3}{2}$  which has value at least 0. Now consider Right plays first, and his possible moves from  $Bx^{2n+1}Bx^{2m+1}B - \frac{3}{2}$ . He can move to:

- $Bx^{2n+1}Bx^{2m+1}B - 1$ . Then Left can answer to  $BWx^{2n}Bx^{2m+1}B - 1$  which has value at least  $\frac{1}{2}$ .
- $B + B + oBx^{2n-1}Bx^{2m+1}B - \frac{3}{2}$ , which has value at least  $B + B + x^{2n}Bx^{2m+1}B - \frac{3}{2}$ , having value more than  $\frac{5}{4}$ .
- $Bx^iBo + B + oBx^{2n-i-2}Bx^{2m+1}B - \frac{3}{2}$ , which has value at least  $Bx^{i+1} + B + x^{2n-i-1}Bx^{2m+1}B - \frac{3}{2}$ , having value more than  $\frac{3}{4}$ .
- $Bx^{2n-1}Bo + B + Bx^{2m+1}B - \frac{3}{2}$ , which has value at least  $Bx^{2n} + B + Bx^{2m+1}B - \frac{3}{2}$ , having value  $\frac{7}{4}$ .
- $Bx^iBx^{2n-i}Bx^{2m+1}B - \frac{3}{2}$ . Then Left can answer to  $Bx^iBx^{2n-i}BWx^{2m}B - \frac{3}{2}$ , which has value more than 0.



Consider Right plays first, and his possible moves from  $Bx^{2n+1}Bx^{2m}B - \frac{3}{2}$ . He can move to:

- $Bx^{2n+1}Bx^{2m}B - 1$ . Then Left can answer to  $BWx^{2n}Bx^{2m}B - 1$  which has value at least 0.
- $B + B + oBx^{2n-1}Bx^{2m}B - \frac{3}{2}$ , which has value at least  $B + B + x^{2n}Bx^{2m}B - \frac{3}{2}$ , having value at least  $\frac{3}{2}$ .
- $Bx^iBo + B + oBx^{2n-i-2}Bx^{2m}B - \frac{3}{2}$ , which has value at least  $Bx^{i+1} + B + x^{2n-i-1}Bx^{2m}B - \frac{3}{2}$ , having value more than  $\frac{3}{4}$ .
- $Bx^{2n-1}Bo + B + Bx^{2m}B - \frac{3}{2}$ , which has value at least  $Bx^{2n} + B + Bx^{2m}B - \frac{3}{2}$ , having value  $\frac{5}{4}$ .
- $Bx^{2n+1}B + B + oBx^{2m-2}B - \frac{3}{2}$ , which has value at least  $Bx^{2n+1}B + B + x^{2m-1}B - \frac{3}{2}$ , having value  $\frac{3}{2}$ .
- $Bx^{2n+1}Bx^iBo + B + oBx^{2m-i-3}B - \frac{3}{2}$ , which has value at least  $Bx^{2n+1}Bx^{i+1} + B + x^{2m-i-2}B - \frac{3}{2}$ , having value more than  $\frac{3}{4}$ .
- $Bx^{2n+1}Bx^{2m-2}Bo + B + B - \frac{3}{2}$ , which has value at least  $Bx^{2n+1}Bx^{2m-1} + B + B - \frac{3}{2}$ , having value more than  $\frac{5}{4}$ .
- $Bx^iBx^{2n-i}Bx^{2m}B - \frac{3}{2}$ , which has value at least  $Bx^iBx^{2n-i} + x^{2m}B - \frac{3}{2}$ , having value at least  $\frac{1}{4}$ .
- $Bx^{2n+1}Bx^iBx^{2m-i-1}B - \frac{3}{2}$ . Then Left can answer to  $Bx^{2n}WBx^iBx^{2m-i-1}B - \frac{3}{2}$ , which has value at least 0.

$Bx^{2n}Bx^{2m+1}B$  has the same value as  $Bx^{2n}Bx^{2m+1}B$ .

We now prove 7. If  $n = 0$ ,  $Bx^{2n}Bx^{2m}W$  has value  $\frac{1}{4}$  and  $Bx^{2n}Bx^{2m+1}W$  has value  $\frac{1}{2}$ , hence for these two cases, we may consider  $n \geq 1$ . If  $m = 0$ ,  $Bx^{2n}Bx^{2m}W$  has value 0 and  $Bx^{2n+1}Bx^{2m}W$  has value  $\frac{1}{2}$ , hence for these two cases, we may consider  $m \geq 1$ . Consider Right plays first, and his possible moves from  $Bx^{2n}Bx^{2m}W$ . He can move to:

- $B + B + oBx^{2n-2}Bx^{2m}W$ , which has value at least  $B + B + x^{2n-1}Bx^{2m}W$ , having value at least  $\frac{3}{2}$ .
- $Bx^iBo + B + oBx^{2n-i-3}Bx^{2m}W$ , which has value at least  $Bx^{i+1} + B + x^{2n-i-2}Bx^{2m}W$ , having value at least 1.
- $Bx^{2n-2}Bo + B + Bx^{2m}W$ , which has value at least  $Bx^{2n-1} + B + Bx^{2m}W$ , having value  $\frac{3}{2}$ .
- $Bx^{2n}B + B + oBx^{2m-2}W$ , which has value at least  $Bx^{2n}B + B + x^{2m-1}W$ , having value  $\frac{3}{2}$ .
- $Bx^{2n}Bx^iBo + B + oBx^{2m-i-3}W$ , which has value at least  $Bx^{2n}Bx^{i+1} + B + x^{2m-i-2}W$ , having value more than 1.
- $Bx^{2n}Bx^{2m-2}Bo + B$ , which has value at least  $Bx^{2n}Bx^{2m-1} + B$ , having value more than  $\frac{7}{4}$ .
- $Bx^{2n}Bx^{2m-1}Bo$ , which has value at least  $Bx^{2n}Bx^{2m}$ , having value at least 1.
- $BBx^{2n-1}Bx^{2m}W$ , having value at least  $\frac{1}{2}$ .
- $Bx^iBx^{2n-i-1}Bx^{2m}W$ . Then Left can answer to  $Bx^iBx^{2n-i-2}WBx^{2m}W$ , which has value at least 0.

- $Bx^{2n-1}BBx^{2m}W$ , which has value at least  $Bx^{2n-1} + Bx^{2m}W$ , having value at least  $\frac{1}{2}$ .
- $Bx^{2n}Bx^iBx^{2m-i-1}W$ . Then Left can answer to  $Bx^{2n-1}WBx^iBx^{2m-i-1}W$ , which has value at least  $\frac{1}{2}$ \*

Consider Right plays first, and his possible moves from  $Bx^{2n+1}Bx^{2m+1}W$ . He can move to:

- $B + B + oBx^{2n-1}Bx^{2m+1}W$ , which has value at least  $B + B + x^{2n}Bx^{2m+1}W$ , having value at least  $\frac{3}{2}$ .
- $Bx^iBo + B + oBx^{2n-i-2}Bx^{2m+1}W$ , which has value at least  $Bx^{i+1} + B + x^{2n-i-1}Bx^{2m+1}W$ , having value at least 1.
- $Bx^{2n-1}Bo + B + Bx^{2m+1}W$ , which has value at least  $Bx^{2n} + B + Bx^{2m+1}W$ , having value  $\frac{7}{4}$ \*
- $Bx^{2n+1}B + B + oBx^{2m-1}W$ , which has value at least  $Bx^{2n+1}B + B + x^{2m}W$ , having value  $\frac{7}{4}$ .
- $Bx^{2n+1}Bx^iBo + B + oBx^{2m-i-2}W$ , which has value at least  $Bx^{2n+1}Bx^{i+1} + B + x^{2m-i-1}W$ , having value more than 1.
- $Bx^{2n+1}Bx^{2m-1}Bo + B$ , which has value at least  $Bx^{2n+1}Bx^{2m} + B$ , having value more than  $\frac{7}{4}$ .
- $Bx^{2n+1}Bx^{2m}Bo$ , which has value at least  $Bx^{2n+1}Bx^{2m+1}$ , having value at least 1.
- $BBx^{2n}Bx^{2m+1}W$ , having value at least  $\frac{1}{2}$ .
- $Bx^iBx^{2n-i}Bx^{2m+1}W$ . Then Left can answer to  $Bx^iBx^{2n-i-1}WBx^{2m+1}W$ , which has value at least  $\frac{1}{2}$ \*
- $Bx^{2n}BBx^{2m+1}W$ , which has value at least  $Bx^{2n} + Bx^{2m+1}W$ , having value  $\frac{3}{4}$ \*
- $Bx^{2n+1}Bx^iBx^{2m-i}W$ . Then Left can answer to  $Bx^{2n}WBx^iBx^{2m-i}W$ , which has value at least 0.

Consider Right plays first, and his possible moves from  $Bx^{2n+1}Bx^{2m}W - \frac{1}{2}$ . He can move to:

- $Bx^{2n+1}Bx^{2m}W$ . Then Left can answer to  $Bx^{2n}WBx^{2m}W$ , which has value 0.
- $B + B + oBx^{2n-1}Bx^{2m}W - \frac{1}{2}$ , which has value at least  $B + B + x^{2n}Bx^{2m}W - \frac{1}{2}$ , having value at least  $\frac{5}{4}$ .
- $Bx^iBo + B + oBx^{2n-i-2}Bx^{2m}W - \frac{1}{2}$ , which has value at least  $Bx^{i+1} + B + x^{2n-i-1}Bx^{2m}W - \frac{1}{2}$ , having value at least  $\frac{1}{2}$ .
- $Bx^{2n-1}Bo + B + Bx^{2m}W - \frac{1}{2}$ , which has value at least  $Bx^{2n} + B + Bx^{2m}W - \frac{1}{2}$ , having value  $\frac{5}{4}$ .
- $Bx^{2n+1}B + B + oBx^{2m-2}W - \frac{1}{2}$ , which has value at least  $Bx^{2n+1}B + B + x^{2m-1}W - \frac{1}{2}$ , having value  $\frac{3}{2}$ .
- $Bx^{2n+1}Bx^iBo + B + oBx^{2m-i-3}W - \frac{1}{2}$ , which has value at least  $Bx^{2n+1}Bx^{i+1} + B + x^{2m-i-2}W - \frac{1}{2}$ , having value more than  $\frac{3}{4}$ .
- $Bx^{2n+1}Bx^{2m-2}Bo + B - \frac{1}{2}$ , which has value at least  $Bx^{2n+1}Bx^{2m-1} + B - \frac{1}{2}$ , having value at least  $\frac{3}{2}$ .

- $Bx^{2n+1}Bx^{2m-1}Bo - \frac{1}{2}$ , which has value at least  $Bx^{2n+1}Bx^{2m} - \frac{1}{2}$ , having value more than  $\frac{1}{4}$ .
- $BBx^{2n}Bx^{2m}W - \frac{1}{2}$ , having value at least  $\frac{1}{4}$ .
- $Bx^iBx^{2n-i}Bx^{2m}W - \frac{1}{2}$ . Then Left can answer to  $Bx^iBx^{2n-i-1}WBx^{2m}W - \frac{1}{2}$ , which has value at least 0.
- $Bx^{2n}BBx^{2m}W - \frac{1}{2}$ , which has value at least  $Bx^{2n} + Bx^{2m}W - \frac{1}{2}$ , having value at least  $\frac{1}{4}$ .
- $Bx^{2n+1}Bx^iBx^{2m-i-1}W - \frac{1}{2}$ . Then Left can answer to  $Bx^{2n}WBx^iBx^{2m-i-1}W - \frac{1}{2}$ , which has value at least 0.

Consider Right plays first, and his possible moves from  $Bx^{2n}Bx^{2m+1}W - \frac{1}{2}$ . He can move to:

- $Bx^{2n}Bx^{2m+1}W$ . Then Left can answer to  $Bx^{2n}BWx^{2m}W$ , which has value 0.
- $B + B + oBx^{2n-2}Bx^{2m+1}W - \frac{1}{2}$ , which has value at least  $B + B + x^{2n-1}Bx^{2m+1}W - \frac{1}{2}$ , having value at least 1.
- $Bx^iBo + B + oBx^{2n-i-3}Bx^{2m+1}W - \frac{1}{2}$ , which has value at least  $Bx^{i+1} + B + x^{2n-i-2}Bx^{2m+1}W - \frac{1}{2}$ , having value at least  $\frac{1}{2}$ .
- $Bx^{2n-2}Bo + B + Bx^{2m+1}W - \frac{1}{2}$ , which has value at least  $Bx^{2n-1} + B + Bx^{2m+1}W - \frac{1}{2}$ , having value  $1^*$ .
- $Bx^{2n}B + B + oBx^{2m-1}W - \frac{1}{2}$ , which has value at least  $Bx^{2n}B + B + x^{2m}W - \frac{1}{2}$ , having value  $\frac{3}{4}$ .
- $Bx^{2n}Bx^iBo + B + oBx^{2m-i-2}W - \frac{1}{2}$ , which has value at least  $Bx^{2n}Bx^{i+1} + B + x^{2m-i-1}W - \frac{1}{2}$ , having value more than  $\frac{3}{4}$ .
- $Bx^{2n}Bx^{2m-1}Bo + B - \frac{1}{2}$ , which has value at least  $Bx^{2n}Bx^{2m} + B - \frac{1}{2}$ , having value at least  $\frac{3}{2}$ .
- $Bx^{2n}Bx^{2m}Bo - \frac{1}{2}$ , which has value at least  $Bx^{2n}Bx^{2m+1} - \frac{1}{2}$ , having value more than  $\frac{1}{4}$ .
- $Bx^iBx^{2n-i-1}Bx^{2m+1}W - \frac{1}{2}$ . Then Left can answer to  $Bx^iBx^{2n-i-1}BWx^{2m}W - \frac{1}{2}$ , which has value at least 0.
- $Bx^{2n}BBx^{2m}W - \frac{1}{2}$ , which has value at least  $Bx^{2n} + Bx^{2m}W - \frac{1}{2}$ , having value  $\frac{1}{4}$ .
- $Bx^{2n}Bx^iBx^{2m-i}W - \frac{1}{2}$ . Then Left can answer to  $Bx^{2n}Bx^iBWx^{2m-i-1}W - \frac{1}{2}$ , which has value at least 0 when  $i$  is odd, or to  $Bx^{2n}Bx^{i-1}WBx^{2m-i}W - \frac{1}{2}$ , which has value at least 0 when  $i$  is even.
- $Bx^{2n}Bx^{2m}BW - \frac{1}{2}$ , having value more than 0.

□



# Bibliography

- [1] Michael H. Albert, Richard J. Nowakowski, David Wolfe. *Lessons in Play*. 2007, A K Peters Ltd.
- [2] Meghan R. Allen. An Investigation of Partizan Misère Games. PhD thesis, Dalhousie University, 2009.
- [3] Meghan R. Allen. Peeking at Partizan Misère Quotients. To appear in *Games of No Chance 4*.
- [4] Elwyn R. Berlekamp, John H. Conway, Richard K. Guy. *Winning ways for your mathematical plays*. Vol. 1, (2nd edition) 2001, A K Peters Ltd.
- [5] Charles L. Bouton, Nim. A Game with a Complete Mathematical Theory. *Annals of Math.* 3 (1905), 35–39.
- [6] Andreas Brandstädt, Feodor Dragan, Victor Chepoi, Vitaly Voloshin, *Dually chordal graphs*, *SIAM J. Discrete Math.* 11 (1998), 437–455.
- [7] Boštjan Brešar, Sandi Klavžar and Douglas F. Rall. Domination game and an imagination strategy. *SIAM J. Discrete Math.* 24 (2010), 979–991.
- [8] Boštjan Brešar, Sandi Klavžar and Douglas F. Rall. Domination game played on trees and spanning subgraphs. *Discrete Math.* 313 (2013), 915–923.
- [9] Kyle G. Burke and Olivia C. George, A PSPACE-complete Graph Nim. To appear in *Games of No Chance 5*.
- [10] John H. Conway. *On Numbers and Games*. (2nd edition), 2001, A K Peters Ltd.
- [11] Erik D. Demaine and Robert A. Hearn. *Games, Puzzles, & Computation*. 2009, A K Peters Ltd.
- [12] Emeric Deutsch. A bijection of Dyck paths and its consequences. *Discrete Math.*, 179 (1998) pp 253–256.
- [13] Paul Dorbec, Gašper Košmrlj, and Gabriel Renault. The domination game played on union of graphs. Manuscript, 2013+.
- [14] Paul Dorbec, Gabriel Renault and Éric Sopena. Toppling Switches. Manuscript, 2012+.

- [15] Paul Dorbec, Gabriel Renault, Aaron N. Siegel and Éric Sopena. Dicots, and a taxonomic ranking for misère games. Manuscript, 2012+.
- [16] Éric Duchêne, Gabriel Renault. VERTEXNIM played on graphs. *Theoretical Computer Science* (accepted)
- [17] Alex Fink, Richard J. Nowakowski, Aaron Siegel, David Wolf. Toppling Conjectures. To appear in *Games of No Chance 4*, Cambridge University Press.
- [18] Aviezri S. Fraenkel, Edward R. Scheinerman, Daniel Ullman. Undirected edge geography. *Theoretical Computer Science* 112 (1993) 371-381.
- [19] Patrick M. Grundy. Mathematics and games, *Eureka*, 2:6–7, 1939.
- [20] William B. Kinnersley, Douglas B. West, and Reza Zamani. Extremal problems for game domination number. submitted, 2012.
- [21] Gašper Košmrlj, Realizations of the game domination number, *Journal of Combinatorial Optimization* (accepted), 2012.
- [22] David Lichtenstein and Michael Sipser. Go is polynomial-space hard. *J. ACM* 27 (1980) 393-401.
- [23] Frédéric Maffray, Myriam Preissmann. Linear recognition of pseudosplit graphs. *Discrete Appl. Math.* 52 (3) (1994) 307-312.
- [24] Neil A. McKay, Rebecca Milley, Richard J. Nowakowski. Misère-play Hackenbush Sprigs. preprint, 2012; available at arxiv 1202:5654.
- [25] G.A. Mesdal and Paul Ottaway. Simplification of partizan games in misère play. *INTEGERS*, 7:#G06, 2007. G.A. Mesdal is comprised of M. Allen, J.P. Grossman, A. Hill, N.A. McKay, R.J. Nowakowski, T. Plambeck, A.A. Siegel, D. Wolfe.
- [26] Rebecca Milley. Restricted Universes of Partizan Misère Games. PhD thesis, Dalhousie University, 2013.
- [27] Rebecca Milley, Richard J. Nowakowski, Paul Ottaway. The misère monoid of one-handed alternating games. *INTEGERS: Electronic J. Comb. Number Theory* 12B (2012) #A1.
- [28] Rebecca Milley and Gabriel Renault. Dead ends in misère play: the misère monoid of canonical numbers. *Discrete Mathematics* 313 (2013), pp. 2223-2231 DOI information: <http://dx.doi.org/10.1016/j.disc.2013.05.023>.
- [29] Richard Nowakowski, Gabriel Renault, Emily Lamoureux, Stephanie Mellon, Timothy Miller. The game of TIMBER! *J. Combin. Math. Combin. Comput.* 85 (2013), 213-215.

- 
- [30] Paul Ottaway, Combinatorial games with restricted options under normal and misère play, PhD thesis, Dalhousie University, 2009.
- [31] Paul Peart and Wen-Jin Woan. Dyck paths with no peaks at height  $k$ . *J. Integer Seq.* (electronic) 4 (2001) Article 01.1.3.
- [32] Thane E. Plambeck. Taming the wild in impartial combinatorial games. *INTEGERS*, 5:#G5, 36pp., Comb. Games Sect., 2005.
- [33] Thane E. Plambeck. Advances in losing. *Games of No Chance 3*, Cambridge University Press, 2008.
- [34] Thane E. Plambeck and Aaron N. Siegel. Misere quotients for impartial games. *Journal of Combinatorial Theory, Series A*, 115(4):593 – 622, 2008.
- [35] H.N. de Ridder et al. Information System on Graph Classes and their Inclusions (ISGCI). 2001-2013 <http://www.graphclasses.org> Accessed on December 3<sup>rd</sup>, 2013.
- [36] Thomas J. Schaefer. On the Complexity of Some Two-Person Perfect-Information Games. *J. Comput. System Sci.* 16 (1978) 185-225.
- [37] Aaron N. Siegel. Combinatorial Game Suite (CGSuite), <http://www.cgsuite.org/>.
- [38] Aaron N. Siegel. Misère canonical forms of partizan games. arxiv preprint math/0703565.
- [39] Aaron N. Siegel. *Combinatorial Game Theory*, 2013, Graduate Studies in Mathematics.
- [40] Neil J. A. Sloane, The On-Line Encyclopedia of Integer Sequences, published electronically at <http://oeis.org/>.
- [41] Roland P. Sprague, Über mathematische Kampfspiele, *Tôhoku Mathematics Journal*, 41:438–444, 1935–36.
- [42] Roland P. Sprague, Über zwei Abarten von Nim, *Tôhoku Mathematics Journal*, 43:351–359, 1937.
- [43] Gwendolyn Stockman. Presentation: The game of nim on graphs: NimG (2004). Available at [http://www.aladdin.cs.cmu.edu/reu/mini\\_probes/papers/final\\_stockman.ppt](http://www.aladdin.cs.cmu.edu/reu/mini_probes/papers/final_stockman.ppt).